

# Ventilation for buildings — Calculation methods for energy losses due to ventilation and infiltration in buildings

ICS 91.140.30

# National foreword

This British Standard is the UK implementation of EN 15241:2007, incorporating corrigendum February 2011.

With respect to the Energy Performance of Buildings Directive (EPBD) requirements, attention is drawn to the text of the fourth paragraph of the EN foreword. This recognizes at the present time that, if there is a conflict, existing national regulations take precedence over any requirements set out in this standard.

The UK participation in its preparation was entrusted to Technical Committee RHE/2, Ventilation for buildings, heating and hot water services.

A list of organizations represented on this committee can be obtained on request to its secretary.

This publication does not purport to include all the necessary provisions of a contract. Users are responsible for its correct application.

**Compliance with a British Standard cannot confer immunity from legal obligations.**

This British Standard was published under the authority of the Standards Policy and Strategy Committee on 31 July 2008

© BSI 2011

ISBN 978 0 580 74698 7

## Amendments/corrigenda issued since publication

Date	Comments
30 June 2011	Incorporation of CEN corrigendum February 2011: Modification of title

English Version

## Ventilation for buildings - Calculation methods for energy losses due to ventilation and infiltration in buildings

Ventilation des bâtiments - Méthode de calcul des pertes  
d'énergie dues à la ventilation et aux infiltrations dans les  
bâtiments

Lüftung von Gebäuden - Berechnungsverfahren für den  
Energieverlust aufgrund der Lüftung und Infiltration in  
Gebäuden

This European Standard was approved by CEN on 26 March 2007.

CEN members are bound to comply with the CEN/CENELEC Internal Regulations which stipulate the conditions for giving this European Standard the status of a national standard without any alteration. Up-to-date lists and bibliographical references concerning such national standards may be obtained on application to the CEN Management Centre or to any CEN member.

This European Standard exists in three official versions (English, French, German). A version in any other language made by translation under the responsibility of a CEN member into its own language and notified to the CEN Management Centre has the same status as the official versions.

CEN members are the national standards bodies of Austria, Belgium, Bulgaria, Cyprus, Czech Republic, Denmark, Estonia, Finland, France, Germany, Greece, Hungary, Iceland, Ireland, Italy, Latvia, Lithuania, Luxembourg, Malta, Netherlands, Norway, Poland, Portugal, Romania, Slovakia, Slovenia, Spain, Sweden, Switzerland and United Kingdom.



EUROPEAN COMMITTEE FOR STANDARDIZATION  
COMITÉ EUROPÉEN DE NORMALISATION  
EUROPÄISCHES KOMITEE FÜR NORMUNG

Management Centre: Avenue Marnix 17, B-1000 Brussels

## Contents

Page

Foreword .....	3
1 Scope.....	6
2 Normative references .....	6
3 Terms and definitions.....	6
4 Symbols and abbreviations .....	7
5 General approach.....	8
6 Steady state calculation .....	9
6.1 Basis of the calculation method.....	9
6.2 Air entering through infiltration, passive air inlets or windows .....	9
6.3 Air entering through balanced or supply only system calculation .....	9
6.3.1 General.....	9
6.3.2 Duct heat losses.....	10
6.3.3 Duct flow losses.....	10
6.3.4 Fan.....	10
6.3.5 heat exchanger.....	13
6.3.6 Mixing boxes .....	15
6.3.7 Pre-heating .....	16
6.3.8 Pre-cooling .....	16
6.3.9 Humidifying in winter.....	17
6.3.10 Dehumidification .....	17
7 Implementation of the method.....	18
7.1 General.....	18
7.2 Hourly method.....	18
7.3 Monthly methods .....	19
7.3.1 System with no or low humidity impact .....	19
7.3.2 System with medium or high humidity impact .....	19
7.4 Statistical approach to be applied at national level .....	20
Annex A (informative) A simplified model of a Ground to Air Heat Exchanger.....	21
A.1 Background and summary.....	21
A.2 Overview of program links, variables, parameters and constants .....	22
A.3 Physical description of the ground to air heat x-change model.....	23
Bibliography .....	26

## **Foreword**

This document (EN 15241:2007) has been prepared by Technical Committee CEN/TC 156 "Ventilation for buildings", the secretariat of which is held by BSI.

This European Standard shall be given the status of a national standard, either by publication of an identical text or by endorsement, at the latest by November 2007, and conflicting national standards shall be withdrawn at the latest by November 2007.

This standard has been prepared under a mandate given to CEN by the European Commission and the European Free Trade Association (Mandate M/343), and supports essential requirements of EU Directive 2002/91/EC on the energy performance of buildings (EPBD). It forms part of a series of standards aimed at European harmonisation of the methodology for the calculation of the energy performance of buildings. An overview of the whole set of standards is given in CEN/TR 15615, Explanation of the general relationship between various CEN standards and the Energy Performance of Buildings Directive (EPBD) ("Umbrella document").

Attention is drawn to the need for observance of relevant EU Directives transposed into national legal requirements. Existing national regulations with or without reference to national standards, may restrict for the time being the implementation of the European Standards mentioned in this report

According to the CEN/CENELEC Internal Regulations, the national standards organizations of the following countries are bound to implement this European Standard: Austria, Belgium, Bulgaria, Cyprus, Czech Republic, Denmark, Estonia, Finland, France, Germany, Greece, Hungary, Iceland, Ireland, Italy, Latvia, Lithuania, Luxembourg, Malta, Netherlands, Norway, Poland, Portugal, Romania, Slovakia, Slovenia, Spain, Sweden, Switzerland and United Kingdom.

## Introduction

This standard defines the way to calculate the energy impact of airflows due to the ventilation system. Ventilation system impact is calculated as direct (energy devoted to the air treatment and move in the ventilation system), and indirect (impact on cooling and heating of the building). The relationships with some other standards are as follows:

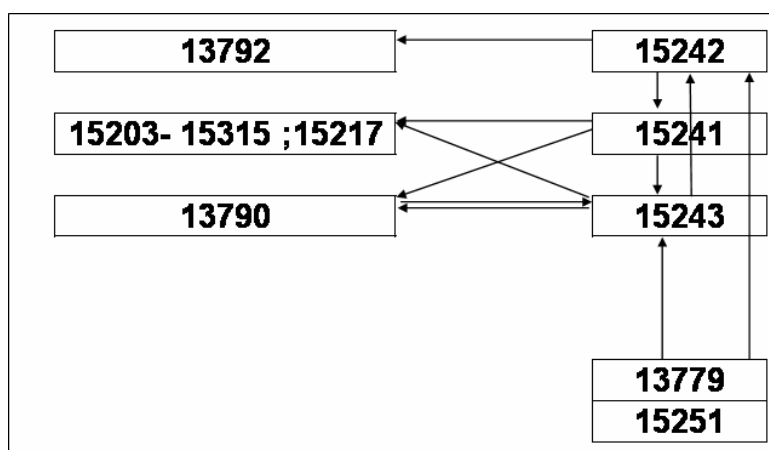

Figure 1 - Scheme of relationship between standards

Table 1 - Relationship between standards

from	To	Information transferred	variables
15251	15243	Indoor climate requirements	Heating and cooling Set points
13779 15251	15242	Airflow requirement for comfort and health	Required supply and exhaust Air flows
15242	15241	Air flows	Air flows entering and leaving the building
15241	13792	Air flows	Air flow for summer comfort calculation
15241	15203-15315 ;15217	energy	Energies per energy carrier for ventilation (fans, humidifying, precooling, pre heating), + heating and cooling for air systems
15241	13790	data for heating and cooling calculation	Temperatures, humidities and flows of air entering the building
15243	15243	Data for air systems	Required energies for heating and cooling
15243	15242	Data for air heating and cooling systems	Required airflows when of use
15243	13790	data for building heating and cooling calculation	Set point, emission efficiency, distribution recoverable losses, generation recoverable losses
13790	15243	Data for system calculation	Required energy for generation

EN titles are:

prEN 15217, *Energy performance of buildings — Methods for expressing energy performance and for energy certification of buildings*

prEN 15603, *Energy performance of buildings — Overall energy use and definition of energy ratings*

prEN 15243, *Ventilation for buildings — Calculation of room temperatures and of load and energy for buildings with room conditioning systems*

prEN ISO 13790, *Thermal performance of buildings — Calculation of energy use for space heating and cooling (ISO/DIS 13790:2005)*

EN 15242, *Ventilation for buildings — Calculation methods for the determination of air flow rates in buildings including infiltration*

EN 15241, *Ventilation for buildings — Calculation methods for energy losses due to ventilation and infiltration in commercial buildings*

EN 13779, *Ventilation for non-residential buildings — Performance requirements for ventilation and room-conditioning systems*

EN 13792, *Colour coding of taps and valves for use in laboratories*

EN 15251, *Indoor environmental input parameters for design and assessment of energy performance of buildings addressing indoor air quality, thermal environment, lighting and acoustics*

The target audience of this standard is policy makers in the building regulation sector, software developers of building simulation tools, industrial and engineering companies.

## **1 Scope**

This European Standard describes the method to calculate the energy impact of ventilation systems (including airing) in buildings to be used for applications such as energy calculations, heat and cooling load calculation.

Its purpose is to define how to calculate the characteristics (temperature, humidity) of the air entering the building, and the corresponding energies required for its treatment and the auxiliaries electrical energy required.

This standard can also be used for air heating and cooling systems when they assure the provision of ventilation, considering that prEN 15243 will provide the required heating or cooling load and the corresponding air flows and/or air temperatures.

## **2 Normative references**

The following referenced documents are indispensable for the application of this document. For dated references, only the edition cited applies. For undated references, the latest edition of the referenced document (including any amendments) applies.

EN 12792:2003, *Ventilation for buildings — Symbols, terminology and graphical symbols*

EN 13053:2006, *Ventilation for buildings — Air handling units — Rating and performance for units, components and sections*

EN 13779, *Ventilation for non-residential buildings — Performance requirements for ventilation and room-conditioning systems*

prEN 15232, *Energy performance of buildings — Impact of Building Automation, Controls and Building Management*

EN 15242, *Ventilation for buildings — Calculation methods for the determination of air flow rates in buildings including infiltration*

prEN 15243, *Ventilation for buildings — Calculation of room temperatures and of load and energy for buildings with room conditioning systems*

prEN ISO 13790, *Thermal performance of buildings — Calculation of energy use for space heating and cooling (ISO/DIS 13790:2005)*

## **3 Terms and definitions**

For the purposes of this document the terms and definitions given in EN 12792:2003 and the following apply.

### **3.1**

#### **defrosting coil**

coil used before the heat exchanger to prevent its frosting

### **3.2**

#### **pre-heating coil**

coil used to warm up the air entering the supply ducted system to a predefined value (e.g.; not controlled according to indoor temperature)

### **3.3**

#### **pre-cooling coil**

coil used to cool down the air entering the supply ducted system to a predefined value



### 3.4

#### building height

height of the building from the entrance ground level to the roof top level

### 3.5

#### building leakage

overall leakage airflow for a given test pressure difference across building

### 3.6

#### building volume

volume within internal outdoor walls of the purposely conditioned space of the building (or part of the building). This generally includes neither the attic, nor the basement, nor any additional structural annex of the building

### 3.7

#### building air temperature

average air temperature of the rooms

## 4 Symbols and abbreviations

Table 2 — symbols and abbreviations

Symbol	Unit	description
$A$	m <sup>2</sup>	area
$Bh$	m	building height
$C_{ductleak}$	ad	coefficient taking into account lost air due to duct leakages
$C_{syst}$	ad	coefficient taking into account the component and system design tolerances
$C_{use}$	ad	coefficient taking into account the switching on and off of fans
$C_{cont}$	ad	coefficient depending on local air flow control
$Eff$	ad	efficiency
$H$	W/K	heat loss
$q_v(dP)$	curve or formula	airflow/pressure difference characteristic
$q_v 4Pa,n$ or $n50,n$	m <sup>3</sup> /h	external envelope airtightness expressed as an airflow for a given pressure difference, exponent
$q_v 4Pa,n$ or $n50,n$	m <sup>3</sup> /h	partial air tightness for altitude (z), orientation (or), tilt angle (Tilt)
$q_{v-exh}$	m <sup>3</sup> /h	exhaust air flow
$q_{v-sup}$	m <sup>3</sup> /h	supply air flow
$P$	W	heating power
$R$	Ad	ratio
$\theta$	°C	temperature
$x$	g/kg of dry air	moisture content of the air

Table 3 — Indices used in the documents

sup	Concerns supply air as defined in EN 13779	rec	Concerns recirculation
exh	Concerns exhaust air as defined in EN 13779	ductsurr	Concerns air surrounding the duct
e1	Concerns exhaust air entering unit	e2	Concerns exhaust air at unit's exit
s1	Concerns supply air entering unit	s2	Concerns supply air at unit's exit
PC	Concerns precooling	PH	Concerns pre-heating
hum	Concerns humidifying	Fan or f	Concerns fan
HE	Concerns heat exchanger	f,r	Concerns heat recovered from fan
ext	external	int	internal
duct	Concerns the duct	cont	control

## 5 General approach

EN 15242 defines the procedure to calculate the following air flows (either entering or leaving the heated/conditioned area) through leakages, opened windows, purpose provided openings (considered as part of the ventilation system) and the ventilation system.

For overall heating and cooling needs calculation, prEN ISO 13790, uses directly the airflows entering the building through leakages, opened windows, and purpose provided opening, as there's is no additional energy impact when these air flows are known. Therefore this standard focuses on the impact on the ventilation system itself both for the air treatment and move.

For air heating and cooling system, prEN 15243 provides the required airflow and supply temperatures.

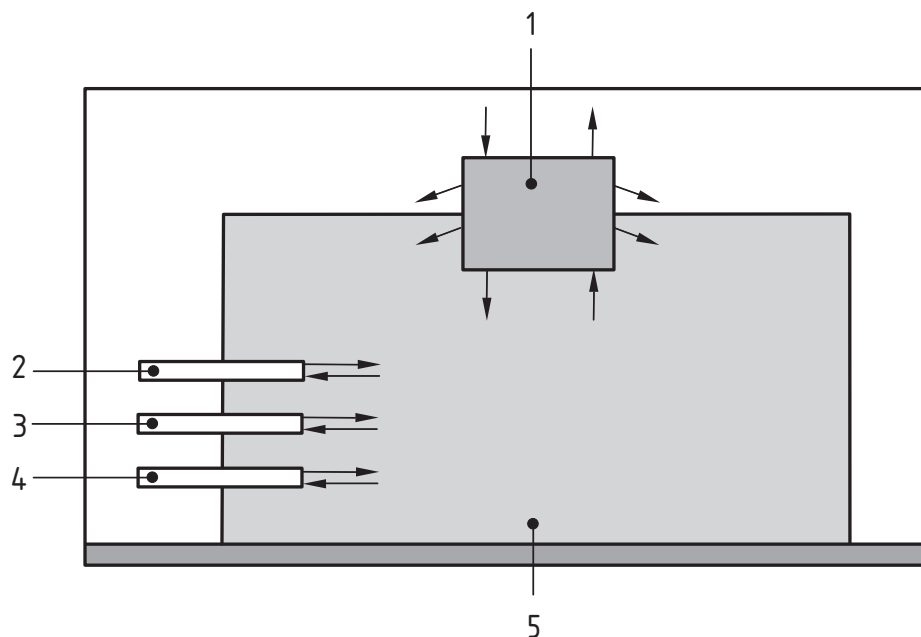

### Key

- |                      |                               |
|----------------------|-------------------------------|
| 1 ventilation system | 4 leakage                     |
| 2 window opening     | 5 internal reference pressure |
| 3 opening            |                               |

Figure 2 — general scheme for airflows

The ventilation system here considered does not directly include room controlled heating and cooling, but only preheating and precooling coils. The local heating or cooling system description and calculation is not considered directly. Its possible impact on the exhaust air temperature or on the required airflows set points and controls can nevertheless be taken into account.

The aim of this standard is therefore to provide the "air information" for heating and cooling calculation methods, which means:

- Air flows (from standard EN 15242), temperature, humidity entering the heated/conditioned area both for ventilation and infiltration.
- Electrical needs for fan and ventilation system auxiliaries;
- Required energy for defrosting, preheating, precooling, humidifying, dehumidifying;
- The heating and cooling energy needs due to infiltration are not part of the standard.

Required energy for heating and cooling for air heating and cooling systems can be taken into account using the same formulas in connection with prEN 15243.

These energies will be provided by energy carrier and use (heating, cooling, ventilating). In some cases it will require some specific assumptions as for example if a fan is used for ventilation, heating and cooling.

Three implementation possibilities of the calculation procedure described in Clause 6 are shown in Clause 7.

## **6 Steady state calculation**

### **6.1 Basis of the calculation method**

Starting from the airflows, the aim of the procedure is to calculate:

- Temperature and humidities of the airflows entering the heated or cooled areas.
- Energy devoted to the air treatment.

### **6.2 Air entering through infiltration, passive air inlets or windows**

It is basically considered that the air characteristics are the outdoor air ones.

Preheated air inlets and ground coupling are part of this standard

If the air is taken in an adjacent space the air temperature in this space shall be calculated according to prEN ISO 13790.

### **6.3 Air entering through balanced or supply only system calculation**

#### **6.3.1 General**

The following subclauses describe how the air characteristics are modified in each component, and the energy required for that treatment.

### 6.3.2 Duct heat losses

#### 6.3.2.1 Heat transfer through the parts of duct situated in the heated/conditioned area

It has to be evaluated if these losses are significant in respect to the accuracy required for the calculations.

They can be neglected for systems not providing heating and cooling.

If not the equations are the same as if the ducts are situated out of the conditioned area but the air temperature surrounding the duct is equal to the zone temperature. If the heat transfer of the zone to the air in the duct is taken into account, the energy balance of the room shall be completed (e.g. the heat transferred to the air shall be lost by the zone).

#### 6.3.2.2 Heat transfer through the parts of duct situated out the heated/conditioned area

The air temperature is modified in the duct as follows:

$$\theta_2 = \theta_1 + \Delta T_{\text{duct}}$$

$$x_2 = x_1$$

where

$\Delta T_{\text{duct}}$  is the difference in air temperature between the inlet and the outlet of the duct, in K

$\theta_1, x_1$  are the air temperature and humidity at the inlet of the duct, (in °C and g/kg of dry air)

$\theta_2, x_2$  are the air temperature and humidity at the outlet of the duct, (in °C and g/kg of dry air)

$\Delta T_{\text{duct}}$  is calculated by

$$\Delta T_{\text{duct}} = (\theta_1 - \theta_{\text{surduct}}) \left( 1 - e^{-\left( \frac{H_{\text{duct}}}{0,34 \cdot q_{\text{vduct}}} \right)} \right) \text{ s}$$

where

$\theta_{\text{surduct}}$  is the temperature of the air surrounding the duct, equal in this case to the outdoor air temperature, in °C

$H_{\text{duct}}$  is the heat loss from the duct to the surrounding, in W/K

$q_{\text{vduct}}$  is the rate of air flow in the duct, in (m<sup>3</sup>/h)

#### 6.3.3 Duct flow losses

The infiltrated or exfiltrated flow into or from the duct is calculated according to EN 15242.

If the air is exfiltrated, there is no change in air characteristics in the duct (but a difference in air flows).

If the air is infiltrated, the outdoor air is mixed to the air entering the duct.

#### 6.3.4 Fan

The air temperature is increased by the fan of a  $\Delta T_{\text{fan}}$  value

$$\Delta T_{fan} = \frac{F_{fan} \cdot R_{f,r}}{\rho \cdot c \cdot q_{vfan}}$$

where:

$\Delta T_{fan}$  is the increase of air temperature caused by fan, in K,

$F_{fan}$  is the fan power, in W,

$R_{f,r}$  is the fan power recovered ratio (ad.),

$\rho c$  is the product of the air density and the specific heat, in 34 Wh/(m<sup>3</sup>·K) . A default value of 0,34 Wh/(m<sup>3</sup>·K) can be taken into account (value at 20 °C)

$q_{vfan}$  is the airflow through the fan, in m<sup>3</sup>/h.

NOTE 1 EN 13779 provides a classification of fan power.

$R_{f,r}$ : The fan power recovered ratio is the ratio of the electrical energy to the fan transferred to the air. Table 4 gives default values. When the position is unknown, the worst value shall be used (motor in airflow for cooling, out of airflow for heating).

**Table 4 —  $R_{f,r}$  values**

Motor in airflow	0,9
Motor out air flow	0,6

For demand controlled ventilation (DCV) or VAV system without any recirculation air (100 % outdoor air), it may be assumed that the fan power consumption in average is similar to the fan power level obtained at the average airflow of  $C_{cont} \cdot q_v$  in order to simplify the calculation.

NOTE 2 Other assumptions may be made if they are described. For instance, if the fan power at maximum speed and minimum speed has importance on the overall result, another calculation method of the average fan absorbed power may be used taking it into account.

For VAV systems with air recirculation,  $C_{cont}$  depends on the action of the outdoor air damper while the fan absorbed power depends of the average supply air ratio compared to the maximum.

Therefore:

- For DCV and VAV systems with 100 % outdoor air: Airflow ratio =  $C_{cont}$
- For VAV systems with recirculation, the airflow ratio is equal to the weighted average airflow in the system divided by the maximum air flow in the system.
- If no design assumption is possible, the average airflow and a default value of 80 % can be used.

Anyhow, the regulation of the fan has to be considered to determine how much the fan absorbed power will be decreased.

If no information is available, the following curve gives for example ideas of the fan absorbed power ratio vs the airflow ratio for different types of regulation.

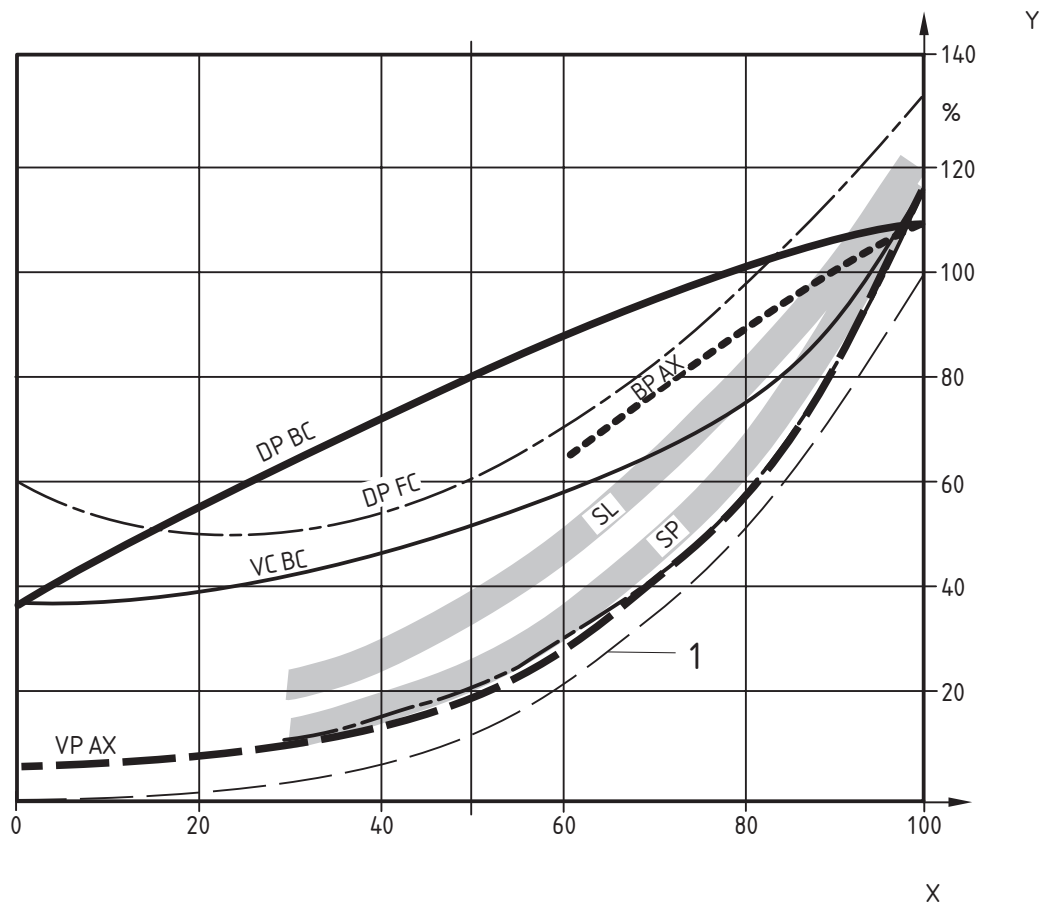

**Key**

X volume flow	VC Variable control	BC Backward curved
Y power input	VP Variable pitch	FC Forward curved
DP Damper control	SP Speed control	
BP By-pass control	SL Slip control	

**Figure 3 — Example of fan absorbed power against air flow**

For instance, if it has been determined that  $C_{cont}$  is 0,5 on a DCV system, it may be assumed that the fan power consumption is equivalent to the power at 50 % ratio, i.e. in this case 30 % of maximum one with speed control.

Therefore, the following Table 5 summarises the ratio that may be applied to the fan power at maximum speed depending on  $C_{cont}$  and regulation type.

**Table 5 (informative) — Example of fan power ratio depending on regulation and airflow ratio**

$$\text{AverageFanPower} = \text{FanPowerRatio} \cdot \text{Fanpower}(\text{at max speed})$$

Airflow ratio	0,2	0,4	0,6	0,8
Damper control on forward blades centrifugal fan	55 %	75 %	90 %	100 %
Damper control on backward blades centrifugal fan	50 %	55 %	70 %	100 %
Speed control	10 %	18 %	35 %	65 %

### 6.3.5 heat exchanger

#### 6.3.5.1 “sensible heat only” heat exchangers

For equal supply and extract airflows, the temperature variations are calculated by :

$$\theta s_2 = \theta s_1 + \Delta T_{HEsup}$$

$$\theta e_2 = \theta e_1 + \Delta T_{HEextr}$$

where

$\theta e_1, x e_1$  are the air extract characteristic before the heat exchanger

$\theta s_1, x s_1$  are the air supply characteristic before the heat exchanger

$$\Delta T_{HEsup} = Eff_{HE} (\theta e_1 - \theta s_1)$$

$$\Delta T_{HEextr} = - \Delta T_{HEsup}$$

$Eff_{HE}$  is the Heat Exchanger efficiency for a given set of equal or almost supply and extract airflows

For single residential supply and exhaust units (tested according to EN 13141-7) overall efficiency includes fan temperature increase when the position of fan allows it to be recovered. It therefore shall be set to 0 in the equation when calculating as it is already included in the efficiency term.

#### 6.3.5.2 Sensible and latent heat exchanger

It is possible to write the equations separating temperature and humidity impacts but products standards have only one point of testing for hygroscopic units, which is not enough to characterize both impacts.

#### 6.3.5.3 Defrosting issues

Defrosting issues are also dealt with in EN 13053:2006, Annex A.

Preventing frosting can be done in 2 ways:

- Direct defrosting control by action on the heat exchanger (bypass, rotary or separate coils), if possible.
- Use of a defrosting coil warming outdoor air.

In both cases, the  $\theta_{e2}$  value is limited to a  $\theta_{e2min}$  value

The following default values  $\theta_{e2min}$  can be used for if no national information is available:

Residential: 5 °C;

Non residential plate exchanger: 0 °C;

Non residential rotary exchanger: -5 °C;

Default value for  $\theta_{setdefrost}$  : 5 °C:

a ) Direct defrosting control:

A correction value  $\Delta(\Delta T_{HEext})_a$  shall be applied on  $\theta_{e2}$

$$\Delta(\Delta T_{HEext})_a = \max(0; \theta_{e2min} - \theta_{e2})$$

if exhaust and supply flow are equal, the same correction has to be applied to  $\theta_{s2}$

$$\Delta(\Delta T_{HEsup})_a = - \Delta(\Delta T_{HEext})_a$$

The corrected value of  $\theta_{s2}$  is lower than the initial ones, which corresponds to the heating penalty devoted to the defrosting

b) Defrosting coil

The outdoor air is warm up to a  $\theta_{setdefrost}$  value. It is required in this case to heat directly the air.  $P_{defrost}$  the heating power, in  $W$ , required to warm up the air is calculated by

$$P_{defrost} = (\max(0; 0,34 q_v (\theta_{setdefrost} - \theta_{s1})))$$

The  $\theta_{setdefrost}$  value shall be calculated to obtain the  $\theta_{e2min}$  value for the heat exchanger, which leads if supply and extract air flows are equal to

$$\theta_{setdefrost} = \theta_{e1} + (\theta_{e2min} - \theta_{e1}) / Eff_{HE}$$

NOTE The  $\theta_{setdefrost}$  increases when the heat exchanger efficiency increases.

The air characteristics are calculated by

$$\theta_{s1} = \theta_{ext}$$

$$x_{s1} = x_{ext}$$

$$\theta_{s2} = \max(\theta_{s1}, \theta_{setdefrost})$$

$$x_{s2} = x_{s1}$$

#### **6.3.5.4 Free cooling - Limitation of supply temperature**

Only valid in case of the presence of a by-pass provision

The  $\theta_{s2}$  temperature can be limited to a  $\theta_{s2max}$  value in order to prevent air heating in a cooling period. The  $\Delta T_{HEsup}$  shall be corrected by a value

$$\Delta(\Delta T_{HEsup}) = \min(0; \max(\theta_{s2max} - \theta_{s2}; \theta_{s1} - \theta_{s2}))$$



if no limitation, it is possible to apply the same formula by setting  $\theta_{s2max}$  to a high value (for example 100 °C)

The new value of  $\theta_{s2}$  with control ( $\theta_{s2c}$ ) is then equal to

$$\theta_{s2c} = \theta_{s2} + \Delta\Delta T_{HEsupa} + \Delta\Delta T_{HEsupb}$$

### 6.3.6 Mixing boxes

The supply air is a mix of outdoor air and recirculated air. Mixing is made in the mixing box (or recirculation box) with dampers.

It is assumed that the air flows to the building (supply and exhaust) are known. The recirculation therefore modifies only the airflows to the outdoor, as follows:

$$q_{vs1} = (1-R_{rec}) q_{s2}$$

$$q_{ve2} = (1-R_{rec}) q_{e1}$$

$$\theta_{s2} = R_{rec} \theta_{e1} + (1-R_{rec}) \theta_{s1}$$

$$x_{s2} = R_{rec} x_{e1} + (1-R_{rec}) x_{s1}$$

$$\theta_{e2} = \theta_{e1}$$

$$x_{e2} = x_{e1}$$

where

$\theta_{e1}$ , is the temperature of the extract air before the mixing box, in °C

$x_{e1}$  is the humidity of the extract air before the mixing box, in g/kg of dry air

$q_{ve1}$  is the air flow of the extract air before the mixing box, in m<sup>3</sup>/h

$\theta_{e2}$ , is the temperature of the extract air after the mixing box

$x_{e2}$  is the humidity of the extract air after the mixing box

$q_{ve2}$  is the air flow of the extract air after the mixing box

$\theta_{s1}$ , is the temperature of the supply air before the mixing box

$x_{s1}$  is the humidity of the supply air before the mixing box

$q_{vs1}$  is the air flow of the supply air before the mixing box

$\theta_{s2}$ , is the temperature of the supply air after the mixing box

$x_{s2}$  is the humidity of the supply air after the mixing box

$q_{vs2}$  is the air flow of the supply air after the mixing box

$R_{rec}$  is the ratio of recirculation air in supply air

## control of recirculation

As for a heat exchanger, the recirculation air ratio can be controlled for saving energy, mainly by increasing the outdoor air when it is beneficial.

### 6.3.7 Pre-heating

The supply air is warmed up to a  $\theta_{\text{SetPH}}$  value for comfort reasons. The heating power required  $P_{\text{preheat}}$  and the temperature and humidity are calculated by

$$P_{\text{preheat}} = \max(0; 0,34 q_{\text{vPH}} (\theta_{\text{SetPH}} - \theta_1))$$

$$\theta_2 = \max(\theta_1, \theta_{\text{SetPH}})$$

$$x_2 = x_1$$

With

$q_{\text{vPH}}$  is the air flow through the preheating coil, in  $\text{m}^3/\text{h}$

$\theta_{\text{SetPH}}$  is the set point for pre heating, in  $^{\circ}\text{C}$

$\theta_1$  is the air temperature before the preheating coil, in  $^{\circ}\text{C}$

$\theta_2$  is the air temperature after the preheating coil

$x_1$  is the air humidity before the preheating coil, in g/kg of dry air

$x_2$  is the air humidity after the preheating coil

Example values for  $\theta_{\text{SetPH}}$  are 12..15  $^{\circ}\text{C}$  depending on the application.

### 6.3.8 Pre-cooling

The supply air is cooled down to a  $\theta_{\text{SetPC}}$  ( $^{\circ}\text{C}$ ) value for comfort reasons. The cooling power

$$P_{\text{precool}} = q_{\text{vPC}} \cdot (0,83 \cdot (x_2 - x_1) + 0,34 (\theta_2 - \theta_1))$$

Where

$q_{\text{vPC}}$  is the air flow through the precooling coil, in  $\text{m}^3/\text{h}$

$\theta_1$  is the air temperature before the precooling coil, in  $^{\circ}\text{C}$

$\theta_2$  is the air temperature after the precooling coil, in  $^{\circ}\text{C}$

$x_1$  is the air humidity before the precooling coil, in g/kg of dry air

$x_2$  is the air humidity after the precooling coil, in g/kg of dry air

$x_2$  and  $\theta_2$  are calculated by

$$x_2 = x_1 + \Delta x_{\text{PC}}$$

$$\theta_2 = \theta_1 + \Delta T_{\text{PC}}$$

With

$$\Delta T_{PC} = \max(0; \theta_1 - \theta_{\text{setPC}})$$

$$\Delta x_{PC} = \min(0; x_{\text{coil}} - x_1) \cdot (1 - BP_{\text{avfactor}})$$

$$x_{\text{coil}} = \text{EXP}(18,8161 - 4110,34 / (\theta_{\text{coil}} + 235))$$

$\theta_{\text{coil}}$ : coil temperature with a default value of 8 °C

$$BP_{\text{avfactor}} = \min(1; (\theta_2 - \theta_{\text{coil}}) / (\theta_1 - \theta_{\text{coil}}))$$

The  $BP_{\text{avfactor}}$  is an averaged Bypass factor taking into account the temperature control and can therefore be higher than the actual coil bypass factor.

### 6.3.9 Humidifying in winter

The air is humidified to a  $x_{\text{sethum}}$  (g/kg of dry air) value

$P_{\text{humid}}$  required heating power to humidify the air at constant temperature is calculated by

$$P_{\text{humid}} = 0,83 q_{\text{vhum}} (0; (x_{\text{sethum}} - x_1))$$

Where

$q_{\text{vhum}}$  is the air flow through the humidifier, in m<sup>3</sup>/h

$x_1$  is the air humidity before the humidifier, in g/kg of dry air

The air characteristics ( $\theta_2, x_2$ ) after the humidifier are

$$\theta_2 = \theta_1$$

$$x_2 = \max(x_1; x_{\text{sethum}})$$

where

$\theta_1$  is the air temperature before the humidifier, in °C

$\theta_2$  is the air temperature after the humidifier, in °C

$x_2$  is the air humidity after the humidifier, in g/kg of dry air

NOTE It is assumed that the air temperature remains constant (water vapour production) or that the air is warmed up to keep it constant (wet pad humidification)

This formula therefore only applies for increasing the humidity in winter for avoiding dryness feeling, and not in summer condition for thermal comfort (evaporative cooling).

### 6.3.10 Dehumidification

This corresponds to the aim of achieving a given level of air humidity. The air is dried to a  $x_{\text{setdeshum}}$  (g/kg of dry air) value

The same formulas as the ones defined in the pre cooling paragraph by adjusting the coil temperature to achieve the humidity set points.

In most cases, a post heating will be required, using the same approach as for the preheating one.

The calculation is done only if  $x_{\text{setdehum}}$  (g/kg of dry air) humidity set point value is lower than  $x_1$ , humidity level before dehumidification coil.

If the bypass factor of the cooling coil  $BP_{\text{coil}}$  is known, the  $w_{\text{coil}}$  is calculated by

$$x_{\text{coil}} = \frac{(x_{\text{setdehum}} - x_1 \cdot BP_{\text{coil}})}{(1 - BP_{\text{coil}})}$$

If the Bypass factor is not known, It is set to 0

The coil and set coil temperatures are calculated by

$$\theta_{\text{coil}} = (4110,34 / (18,8161 - \ln(x_{\text{coil}})) - 235$$

$$\theta_{\text{setcoil}} = -\theta_{\text{coil}}$$

Powers have to be summed for each hour over the considered period.

## **7 Implementation of the method**

### **7.1 General**

The general fields of application are as follows:

- Hourly methods
- Monthly methods
- Statistical methods

Before implementing the calculation procedure, the type and performance of control has to be defined in accordance with prEN 15232.

### **7.2 Hourly method**

If there is no air entering through balanced or supply only system calculation, the air characteristics is calculated as defined in 6.2. The fan (if there is one) energy has to be taken into account.

In other cases, on the basis of the components impact, the calculation is done as follows:

1. Define at the beginning of the yearly calculation the system characteristics, except set points and indoor/outdoor climates.
2. Define for the hour:
  - The outdoor air characteristics ( $\theta_{\text{ext}}, w_{\text{ext}}$ );
  - The indoor air characteristics ( $\theta_{\text{int}}, w_{\text{int}}$ ). In order to avoid loops, it is allowed to use the values calculated at the previous hour;
  - The set points to be used;
  - The air flows.

3. Apply the following steps:
- Calculation of extract air characteristics and before heat exchanger  
Outdoor Duct (heat and mix with infiltrated air)
  - Calculation of supply air before heat exchanger  
Defrost
  - Calculation of extract and supply air after heat exchanger  
Heat exchanger
  - Calculation of additional treatment on supply air
    - a) Fan
    - b) Outdoor duct heat losses
    - c) Preheating
    - d) Precooling
    - e) Humidifying

This order may not be the actual one, but is correct considering the calculation of temperatures, humidities and energies with the following assumptions:

- Control of preheating and precooling is done on the air supplied to the heat/conditioned zone. The duct losses and fan impact are therefore compensated;
- Temperature set point for precooling is lower than the set point for preheating (should be mandatory!);
- Humidity set point for humidifying is lower than the saturation humidity for cool coil (or running of both should be forbidden).

### 7.3 Monthly methods

#### 7.3.1 System with no or low humidity impact

The same approach is used by taking into account the monthly distribution (ranges of outdoor temperature with corresponding occurrences) of outdoor temperatures and making the calculation for each range of outdoor temperature and making an assumption on the corresponding indoor temperatures.

The final results is the yearly (monthly) values of energy for preheating, precooling and auxiliaries taking into account the statistical occurrence for each range of outdoor temperature. If the results can be proved to be linear with the outdoor temperature at national level, it is possible to base the calculation only on an average monthly value.

#### 7.3.2 System with medium or high humidity impact

The same approach is used by taking into account the yearly (monthly) distribution of outdoor temperature and outdoor humidities and making an assumption on the corresponding indoor temperatures and humidities. As the results are in this case highly non linear with the outdoor

temperature or humidity, it is not possible to base the calculation on monthly averaged outdoor temperatures and humidities.

The final results are the yearly (monthly) value on energy for preheating, precooling and auxiliaries.

#### **7.4 Statistical approach to be applied at national level**

It is allowed to define on a national basis simplified approaches based on a statistically analysis of results.

The following rules shall be fulfilled:

- Field of application shall be specified (for example, detached houses, specified ventilation system...);
- Specific assumptions (such as indoor temperature) or data (for example climate) shall be clearly described;
- Set of cases used for the statistical analysis shall be clearly described;
- Remaining inputs data for the simplified approach shall be the same as the ones described in the steady state calculation, or part of them;
- For the input data of the steady state calculation not taken into account, the conventional value used shall be specified (for example, no defrosting in a mild climate);
- Results of the simplified approach shall be compared to the reference ones for the set of cases taken into account in the statistical analysis.

A report shall be provided with two parts

##### **1) Description of the statistically based simplified approach defining**

- The field of application,
- The remaining input data,
- The calculation method,
- The remaining output data.

##### **2) justification of the results**

The main aim is to make it possible to redo and check the calculation starting from this steady state calculation

- Definition of the cases taken into account for the statistical analysis, including:
  - Conventional values for the input data not kept in the simplified method.
  - Range of values for the input data kept in the simplified approach.
  - Results of the different test cases (called reference results).
  - Description of the simplified approach and comparison of the reference results.
  - Indication on the level of accuracy based on the comparison.

## Annex A (informative)

### A simplified model of a Ground to Air Heat Exchanger

#### A.1 Background and summary

This is a simplified model to calculate air preheating due to supplying air through ducts lying in the ground.

The model calculates:

- leaving air temperature of the heat exchanger;
- heat flux between ground and air in duct;
- pressure losses depending on the air velocity and the specific duct parameters.

The background for this simplified model is taken from the “Handbook of passive cooling”<sup>1)</sup>. The model takes into consideration the specific duct parameters and the inertia of the ground, depending on the depth of the ducts lying in the ground.

Also the ground material is taken into account by a correction factor for the ground temperature.

In this simplified model the ground temperature depends on two parameters: the annual mean outside air temperature and the depth of ducts.

The ground temperature is modelled as a sinus curve based on the annual mean outside air temperature. The depth of ducts corrects the sinus curve in two ways:

1. The amplitude decreases in function of the depth.
2. The ground temperature is retarded in function of the depth. It means the inertia of the ground increases in function of the depth.

---

1) „Handbuch der passiven Kühlung“, Mark Zimmermann, EMPA, Juni 1999.

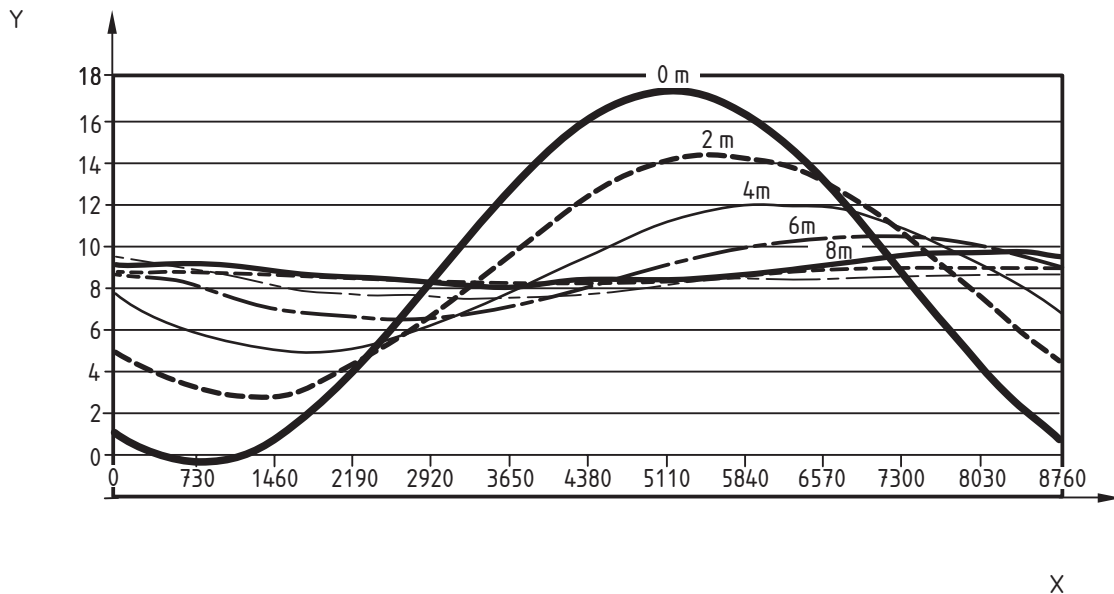

**Key**

X annual hour  
Y temperature [T]

**Figure A.1 — Ground temperatures for several duct depths**

**A.2 Overview of program links, variables, parameters and constants**

**A.2.1 Input variables**

TAirIn "Temp of entering air"  
MAir "Dry air massflow rate"

**A.2.2 Output variables**

PAirOut "Pressure of leaving air"  
TAirOut "Temp of leaving air"  
Q "Heat flux from soil to air"  
dp "Pressure losses"

**A.2.3 Local variables**

TG "Soil temperature"  
hi "Int. surf. coefficient"  
Ud "U-value duct"  
VAir "Volume flow"



v0 "Velocity in duct"

JH "Annual hour"

#### A.2.4 Parameters

nd "number of ducts"

depth "Depth of the duct in ground"

ld "Length of the ducts"

di "Duct inside diameter"

td "Duct wall thickness "

rd "Roughness of duct surface"

kd "Conductivity of the duct"

gm "Ground Material factor"

TAM "Annual mean outside temperature"

#### A.2.5 Calculated parameters

AC "Cross-section"

AS "Surface Area"

do "Duct outside diameter"

AH "Amplitude correction factor"

VS "Curve shift"

#### A.2.6 Constants

Rho\_Air "Air Density"

CP\_Air "Specific heat capacity"

### A.3 Physical description of the ground to air heat x-change model

#### A.3.1 U-Value of the air duct

##### A.3.1.1 Volume flow and air velocity

$$\dot{V}_{Air} = \frac{\dot{M}_{Air}}{n_d \times Rho_{Air}} \quad (A.1)$$

$$v_0 = \frac{\dot{V}_{Air}}{AC} \quad (A.2)$$

##### A.3.1.2 Inside surface coefficient

The inside surface coefficient  $h_i$  is calculated by the formula of Schack<sup>2)</sup>.

$$h_i = \left[ 4,13 + 0,23 \times \frac{\theta_m}{100} - 0,0077 \times \left( \frac{\theta_m}{100} \right)^2 \right] \times \frac{v_0^{0,75}}{d_i^{0,25}} \quad (A.3)$$

---

2) Taschenbuch Heizung+Klimatechnik 97/98, Recknagel.

$\theta_m$  is the arithmetic mean value of entering and leaving temperature. To avoid iteration, Equation A.3 can be simplified by setting  $\theta_m = T_{airIn}$ .

### A.3.1.3 U-Value

$$U_d = \left( \frac{1}{2\pi} \times \frac{1}{k_d} \times \ln \frac{\frac{d_o}{2}}{\frac{d_i}{2}} + \frac{1}{h_i} \right)^{-1} \quad (\text{A.4})$$

## A.3.2 Ground temperature

### A.3.2.1 General

The ground temperature depends on the annual mean and the amplitude of the annual swing of the outside air temperature at the building location, and on the depth of the duct in the ground. To take into consideration the inertia of the ground, the outside air temperature is corrected by AH, VS and gm.

### A.3.2.2 AH – Amplitude

AH corrects the amplitude, depending on the depth of the ducts lying in the ground.

$$AH = -0,000335 \cdot depth^3 + 0,01381 \cdot depth^2 - 0,1993 \cdot depth + 1 \quad (\text{A.5})$$

### A.3.3 VS – Curve shift

#### A.3.3.1 General

VS correct the ground temperature by a time shift, depending on the depth of the ducts lying in the ground.

$$VS = 24 \cdot (-0,0195 \cdot depth^4 + 0,3385 \cdot depth^3 - 1,0156 \cdot depth^2 + 10,298 \cdot depth + 0,1786) \quad (\text{A.6})$$

#### A.3.3.2 Ground Temperature

$$T_G = gm \cdot \left[ T_{AM} - AH \cdot \Delta T_A \cdot \sin \left[ \frac{2\pi}{8760} \cdot [JH - VS + 24,25] \right] \right] \quad (\text{A.7})$$

with  $\Delta T_A$  being the Amplitude of the annual outside air temperature swing. It can be calculated as the difference of the maximum (e.g. July) and minimum (e.g. Jan.) *monthly* mean temperatures, divided by 2.

Table A.1 — gm values for soil materials

Ground Material	Conductivity [W/mK]	Density [kg/m3]	Capacity [J/kgK]	Correction gm Factor
Moist soil	1,5	1400	1400	1,00
Dry sand	0,7	1500	920	0,90
Moist sand	1,88	1500	1200	0,98
Moist clay	1,45	1800	1340	1,04
Wet clay	2,9	1800	1590	1,05

### A.3.3.3 Temperature of leaving Air

$$T_{AirOut} = T_G - (T_G - T_{AirIn}) \times e^{\left(\frac{-U_d \times AS}{M_{Air} \times CP - Air}\right)} \quad (A.8)$$

with  $AS = d_i \times \pi \times l_d$  (A.9)

### A.3.4 Heat flux from ground to air

$$Q = AS \times U_d \times \left(T_G - \frac{T_{AirIn} + T_{AirOut}}{2}\right) \quad (A.10)$$

### A.3.5 Pressure losses of the heat exchanger

The pressure losses are calculated as for any other duct, depending on material properties, size and velocity

## **Bibliography**

- [1] EN 1886, *Ventilation for buildings — Air handling units — Mechanical performance*
- [2] EN 13141-7, *Ventilation for buildings — Performance testing of components/products for residential ventilation - Part 7: Performance testing of a mechanical supply and exhaust ventilation units (including heat recovery) for mechanical ventilation systems intended for single family dwellings*
- [3] EN 13465, *Ventilation for buildings — Calculation methods for the determination of air flow rates in dwellings*



---

## BSI - British Standards Institution

BSI is the independent national body responsible for preparing British Standards. It presents the UK view on standards in Europe and at the international level. It is incorporated by Royal Charter.

### Revisions

British Standards are updated by amendment or revision. Users of British Standards should make sure that they possess the latest amendments or editions.

It is the constant aim of BSI to improve the quality of our products and services. We would be grateful if anyone finding an inaccuracy or ambiguity while using this British Standard would inform the Secretary of the technical committee responsible, the identity of which can be found on the inside front cover. Tel: +44 (0)20 8996 9000. Fax: +44 (0)20 8996 7400.

BSI offers members an individual updating service called PLUS which ensures that subscribers automatically receive the latest editions of standards.

### Buying standards

Orders for all BSI, international and foreign standards publications should be addressed to Customer Services. Tel: +44 (0)20 8996 9001. Fax: +44 (0)20 8996 7001 Email: [orders@bsigroup.com](mailto:orders@bsigroup.com) You may also buy directly using a debit/credit card from the BSI Shop on the Website <http://www.bsigroup.com/shop>

In response to orders for international standards, it is BSI policy to supply the BSI implementation of those that have been published as British Standards, unless otherwise requested.

### Information on standards

BSI provides a wide range of information on national, European and international standards through its Library and its Technical Help to Exporters Service. Various BSI electronic information services are also available which give details on all its products and services. Contact Information Centre. Tel: +44 (0)20 8996 7111 Fax: +44 (0)20 8996 7048 Email: [info@bsigroup.com](mailto:info@bsigroup.com)

Subscribing members of BSI are kept up to date with standards developments and receive substantial discounts on the purchase price of standards. For details of these and other benefits contact Membership Administration. Tel: +44 (0)20 8996 7002 Fax: +44 (0)20 8996 7001 Email: [membership@bsigroup.com](mailto:membership@bsigroup.com)

Information regarding online access to British Standards via British Standards Online can be found at <http://www.bsigroup.com/BSOL>

Further information about BSI is available on the BSI website at <http://www.bsigroup.com>

### Copyright

Copyright subsists in all BSI publications. BSI also holds the copyright, in the UK, of the publications of the international standardization bodies. Except as permitted under the Copyright, Designs and Patents Act 1988 no extract may be reproduced, stored in a retrieval system or transmitted in any form or by any means – electronic, photocopying, recording or otherwise – without prior written permission from BSI.

This does not preclude the free use, in the course of implementing the standard, of necessary details such as symbols, and size, type or grade designations. If these details are to be used for any other purpose than implementation then the prior written permission of BSI must be obtained.

Details and advice can be obtained from the Copyright and Licensing Manager. Tel: +44 (0)20 8996 7070 Email: [copyright@bsigroup.com](mailto:copyright@bsigroup.com)