

Products and systems for the protection and repair of concrete structures — Test methods — Corrosion protection test

The European Standard EN 15183:2006 has the status of a
British Standard

ICS 91.080.40

National foreword

This British Standard was published by BSI. It is the UK implementation of EN 15183:2006.

The UK participation in its preparation was entrusted by Technical Committee B/517, Concrete, to Subcommittee B/517/8, Protection and repair of concrete structures.

A list of organizations represented on B/517/8 can be obtained on request to its secretary.

This publication does not purport to include all the necessary provisions of a contract. Users are responsible for its correct application.

Compliance with a British Standard cannot confer immunity from legal obligations.

This British Standard was published under the authority of the Standards Policy and Strategy Committee on 31 October 2006

© BSI 2006

ISBN 0 580 49325 3

Amendments issued since publication

Amd. No.	Date	Comments

EUROPEAN STANDARD

EN 15183

NORME EUROPÉENNE

EUROPÄISCHE NORM

August 2006

ICS 91.080.40

English Version

Products and systems for the protection and repair of concrete structures - Test methods - Corrosion protection test

Produits et systèmes pour la protection et la réparation des structures en béton - Méthodes d'essais - Essai d'évaluation de la protection anticorrosion

Produkte und Systeme für den Schutz und die Instandsetzung von Betontragwerken - Prüfverfahren - Prüfung des Korrosionsschutzes

This European Standard was approved by CEN on 19 June 2006.

CEN members are bound to comply with the CEN/CENELEC Internal Regulations which stipulate the conditions for giving this European Standard the status of a national standard without any alteration. Up-to-date lists and bibliographical references concerning such national standards may be obtained on application to the Central Secretariat or to any CEN member.

This European Standard exists in three official versions (English, French, German). A version in any other language made by translation under the responsibility of a CEN member into its own language and notified to the Central Secretariat has the same status as the official versions.

CEN members are the national standards bodies of Austria, Belgium, Cyprus, Czech Republic, Denmark, Estonia, Finland, France, Germany, Greece, Hungary, Iceland, Ireland, Italy, Latvia, Lithuania, Luxembourg, Malta, Netherlands, Norway, Poland, Portugal, Romania, Slovakia, Slovenia, Spain, Sweden, Switzerland and United Kingdom.



EUROPEAN COMMITTEE FOR STANDARDIZATION
COMITÉ EUROPÉEN DE NORMALISATION
EUROPÄISCHES KOMITEE FÜR NORMUNG

Management Centre: rue de Stassart, 36 B-1050 Brussels

Contents

Page

Foreword.....	3
1 Scope	4
2 Normative references	4
3 Terms and definitions	4
4 Principle.....	4
5 Equipment	5
6 Method of test	5
7 Test report	7
Bibliography.....	9

Foreword

This document (EN 15183:2006) has been prepared by Technical Committee CEN/TC 104 "Concrete and related products", the secretariat of which is held by DIN.

This European Standard shall be given the status of a national standard, either by publication of an identical text or by endorsement, at the latest by February 2007, and conflicting national standards shall be withdrawn at the latest by December 2008.

This European Standard is one of a series dealing with products and systems for the protection and repair of concrete structures. It describes a method of testing the corrosion protection provided by coatings for application to reinforcing bars.

According to the CEN/CENELEC Internal Regulations, the national standards organizations of the following countries are bound to implement this European Standard: Austria, Belgium, Cyprus, Czech Republic, Denmark, Estonia, Finland, France, Germany, Greece, Hungary, Iceland, Ireland, Italy, Latvia, Lithuania, Luxembourg, Malta, Netherlands, Norway, Poland, Portugal, Romania, Slovakia, Slovenia, Spain, Sweden, Switzerland and United Kingdom.

1 Scope

This European Standard specifies a method for determining the corrosion protection performance of corrosion protection products or systems, as defined in EN 1504-7.

2 Normative references

The following referenced documents are indispensable for the application of this document. For dated references, only the edition cited applies. For undated references, the latest edition of the referenced document (including any amendments) applies.

EN 196-1, *Methods of testing cement — Part 1: Determination of strength*

EN 1504-1:2005, *Products and systems for the protection and repair of concrete structures — Definitions, requirements, quality control and evaluation of conformity — Part 1: Definitions*

EN 1504-7:2006, *Products and systems for the protection and repair of concrete structures — Definitions, requirements, quality control and evaluation of conformity — Part 7: Reinforcement corrosion protection*

ENV 1504-9:1997, *Products and systems for the protection and repair of concrete structures — Definitions, requirements, quality control and evaluation of conformity — Part 9: General principles for the use of products and systems*

EN 1766, *Products and systems for the protection and repair of concrete structures — Test methods — Reference concretes for testing*

EN 10027-1, *Designation systems for steels — Part 1: Steel names*

EN 10080, *Steel for the reinforcement of concrete — Weldable reinforcing steel — General*

EN 60068-2-11, *Environmental testing — Part 2: Tests — Test Ka: Salt mist (IEC 60068-2-11:1981)*

EN ISO 4287, *Geometrical product specifications (GPS) — Surface texture: Profile method — Terms, definitions and surface texture parameters (ISO 4287:1997)*

EN ISO 6988, *Metallic and other non-organic coatings — Sulfur dioxide test with general condensation of moisture (ISO 6988:1985)*

EN ISO 12944-4, *Paints and varnishes — Corrosion protection of steel structures by protective paint systems — Part 4: Types of surface and surface preparation (ISO 12944-4:1998)*

ISO 8486-1, *Bonded abrasives — Determination and designation of grain size distribution — Part 1: Macrogrits F4 to F220*

3 Terms and definitions

For the purposes of this document, the terms and definitions given in EN 1504-1:2005, EN 1504-7:2006 and ENV 1504-9:1997 apply.

4 Principle

The corrosion protection system is applied to steel rods and to a steel plate. The coating is removed from one longitudinal edge of the steel plate to investigate the potential for underfilm corrosion. Half of the plate and

each of the bars are embedded in concrete. The specimens are exposed to a series of weathering cycles. Performance is assessed by removing the steel from the concrete, then removing the corrosion protection product and examining the steel for evidence of corrosion on the steel.

5 Equipment

- 5.1 **Standard laboratory** climate, $(21 \pm 2) ^\circ\text{C}$ and $(60 \pm 10) \% \text{RH}$;
- 5.2 **Concrete mixer**, in accordance with EN 196-1, or forced action pan mixer;
- 5.3 **Compaction tools** and equipment in accordance with EN 196-1;

NOTE The compaction method should be in accordance with the manufacturer's instruction.

- 5.4 **Mould** for producing specimen made from non-absorbent, rigid material, not attacked by cement paste or polymers, of (100 ± 5) mm internal diameter and (100 ± 5) mm depth;
- 5.5 **Stirrer** to mix the corrosion protection material;
- 5.6 **Brush** for application of the corrosion protection material;
- 5.7 **Four steel rods**, Class S235, 2 of dia. 8 mm \times 200 mm, 2 of dia. 16 mm \times 200 mm;
- 5.8 **One steel plate**, 200 mm \times 90 mm \times 1,5 mm, with defined surface roughness (see Figure 1);
- 5.9 **Belt grinder** and 150 grain size abrasive paper of grade F150 according to ISO 8486-1;
- 5.10 **Test chamber** according to EN ISO 6988;
- 5.11 **pH-meter**;
- 5.12 **Beaker**;
- 5.13 **Measure for rust creep** with an accuracy of 0,1 mm.

6 Method of test

6.1 Preparation of specimens

6.1.1 Preparation of steel plate and rods

The surface of the steel reinforcing rods and the steel plate in Figure 1 shall be prepared according to EN ISO 12944-4, to a standard degree of purity of Sa 2 ½ (or according to the manufacturer's instructions). The resulting surface roughness of the steel plate shall be $R_z = 30 \mu\text{m}$ to $50 \mu\text{m}$ according to EN ISO 4287.

NOTE Sa 2½ is required for this test method, but may not always be achieved in site repairs. See EN 1504-10.

The rods and the steel plate shall be coated completely (on all sides) with the corrosion protection system according to the manufacturer's instructions. During application and hardening of the coating, the steel rods shall be stored upright and the steel plate flat.

After the waiting period prescribed by the manufacturer, preferably 7 days, the coating shall be removed from one longitudinal edge of the steel plate by grinding in the direction of the longitudinal edge, e. g. with a belt grinder and 150 grain size abrasive, without affecting the bond between the coating and the plate. The steel

specimens shall then be half-embedded in the mould according to 6.1.2 and stored at $(21 \pm 2) ^\circ\text{C}$ and $(60 \pm 10) \% \text{RH}$.

Dimensions in millimetres

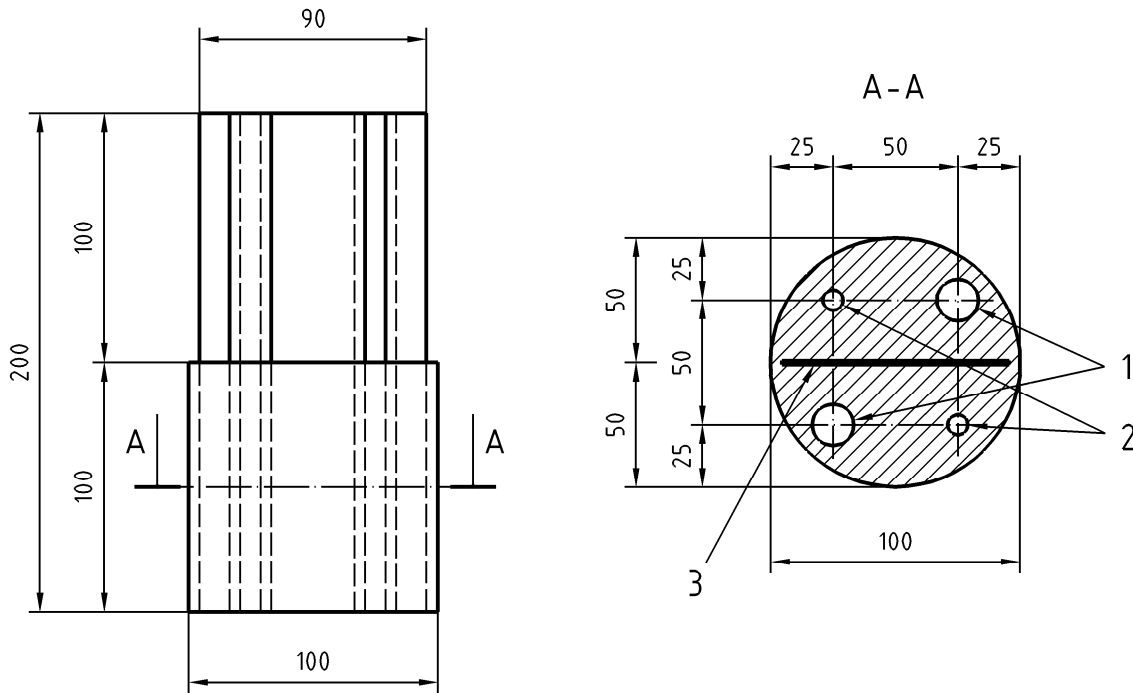

Key

- 1 B 500 B 16 X 200
 - 2 B 500 B 8 X 200
 - 3 Steel plate 200 X 90 X 1,5 S 235
- Steel plate: S 235 JRG according to EN 10027-1: Steel rods according to EN 10080

Figure 1 — Specimens for testing corrosion protection coating

6.1.2 Preparation of concrete

The specimen shall be cast using type MC (0,45) concrete in accordance with EN 1766, with maximum grain size of 4 mm. Alternatively for protection systems consisting of concrete and coating the concrete can be used instead of the MC (0,45).

All materials shall be conditioned at $(21 \pm 2) ^\circ\text{C}$ and $(60 \pm 10) \% \text{RH}$ for at least 24 h prior to mixing.

The steel plate and the bars shall be located in the mould with a minimum of 5 mm separation between the bars, plate and internal surface of the mould.

The mixed material shall be placed into the cylindrical mould and compacted thoroughly by vibro-compaction or as otherwise instructed by the manufacturer. Release of the concrete shall be achieved by lining the base of the mould with a suitable film, which does not react with the repair product or system. A light smearing of mould oil may be used on the sides of the mould before assembling the base plate.

6.1.3 Curing

The specimens shall be demoulded after 24 h and cured for 7 days at (21 ± 2) °C and (60 ± 10) % RH or as otherwise agreed with the manufacturer.

6.2 Test procedure

The specimen shall be placed flat (ground plate edge facing downwards) in the test chamber and subjected to the following tests:

- 10 condensation water test cycles;
- 10 test cycles (each 24 h) according to EN ISO 6988 (0,2 l SO₂);
- 5 days according to EN 60068-2-11 (salt mist).

One condensation water cycle consists of

- 8 h at (40 ± 3) °C; the level of water in the bottom tub shall be at least 10 mm (relative air humidity 100 % with condensation of water on the specimen surface);
- 16 h at (21 ± 2) °C with opened or ventilated chamber (relative air humidity < 75 %).

After completion of the test cycles, the exposed steel plate and bars shall be examined for evidence of damage or corrosion. The plate and bars shall then be carefully removed from the concrete and the embedded steel examined.

After removal of the concrete, the reinforcing rods and the steel plate shall be inspected visually for rusting and the steel plate for rust creep beneath the corrosion protection coating. To assess rust creep, the coating shall be removed (mechanically or chemically), starting from the ground edge of the steel plate, in such a way that any corrosion becomes visible.

The rust creep shall not exceed 1,0 mm at any point on the steel plate.

7 Test report

The test report shall include the following information:

- a) Reference to the test method standard;
- b) Name and address of the test laboratory;
- c) Identification number and date of the test;
- d) Name and address of the manufacturer or supplier of the product;
- e) Name and identification marks or batch number of the product;
- f) Date of supply of the product;
- g) Date of preparation of the test specimen and any deviation from the prescribed method of preparation;
- h) Mass of material applied and the thickness of the dried coating layer on the unsanded side of the steel plate;
- i) Conditions of storage of prepared specimens prior to test;

EN 15183:2006 (E)

- j) Date of test and details of the test equipment used, including the make, type and capacity and the calibration details or the identification number of the apparatus;
- k) Results (including photographs of each side of the plate if the material fails the test) of the visual inspection of the surface of the reinforcing rods and the steel plate: number and size of rust spots on the rods and the mean and maximum distance of the rust creep front from the ground edge of the steel plate;
- l) Date of test report and signature.

Bibliography

- [1] EN 1504-10, *Products and systems for the protection and repair of concrete structures - Definitions, requirements, quality control and evaluation of conformity - Part 10: Site application of products and systems and quality control of the works*

BSI — British Standards Institution

BSI is the independent national body responsible for preparing British Standards. It presents the UK view on standards in Europe and at the international level. It is incorporated by Royal Charter.

Revisions

British Standards are updated by amendment or revision. Users of British Standards should make sure that they possess the latest amendments or editions.

It is the constant aim of BSI to improve the quality of our products and services. We would be grateful if anyone finding an inaccuracy or ambiguity while using this British Standard would inform the Secretary of the technical committee responsible, the identity of which can be found on the inside front cover.
Tel: +44 (0)20 8996 9000. Fax: +44 (0)20 8996 7400.

BSI offers members an individual updating service called PLUS which ensures that subscribers automatically receive the latest editions of standards.

Buying standards

Orders for all BSI, international and foreign standards publications should be addressed to Customer Services. Tel: +44 (0)20 8996 9001.
Fax: +44 (0)20 8996 7001. Email: orders@bsi-global.com. Standards are also available from the BSI website at <http://www.bsi-global.com>.

In response to orders for international standards, it is BSI policy to supply the BSI implementation of those that have been published as British Standards, unless otherwise requested.

Information on standards

BSI provides a wide range of information on national, European and international standards through its Library and its Technical Help to Exporters Service. Various BSI electronic information services are also available which give details on all its products and services. Contact the Information Centre.
Tel: +44 (0)20 8996 7111. Fax: +44 (0)20 8996 7048. Email: info@bsi-global.com.

Subscribing members of BSI are kept up to date with standards developments and receive substantial discounts on the purchase price of standards. For details of these and other benefits contact Membership Administration.
Tel: +44 (0)20 8996 7002. Fax: +44 (0)20 8996 7001.
Email: membership@bsi-global.com.

Information regarding online access to British Standards via British Standards Online can be found at <http://www.bsi-global.com/bsonline>.

Further information about BSI is available on the BSI website at <http://www.bsi-global.com>.

Copyright

Copyright subsists in all BSI publications. BSI also holds the copyright, in the UK, of the publications of the international standardization bodies. Except as permitted under the Copyright, Designs and Patents Act 1988 no extract may be reproduced, stored in a retrieval system or transmitted in any form or by any means – electronic, photocopying, recording or otherwise – without prior written permission from BSI.

This does not preclude the free use, in the course of implementing the standard, of necessary details such as symbols, and size, type or grade designations. If these details are to be used for any other purpose than implementation then the prior written permission of BSI must be obtained.

Details and advice can be obtained from the Copyright & Licensing Manager.
Tel: +44 (0)20 8996 7070. Fax: +44 (0)20 8996 7553.
Email: copyright@bsi-global.com.