

Precast concrete products — Beam-and-block floor systems —

Part 1: Beams

ICS 91.100.30

National foreword

This British Standard is the UK implementation of EN 15037-1:2008.

The UK participation in its preparation was entrusted to Technical Committee B/524, Precast concrete products.

A list of organizations represented on this committee can be obtained on request to its secretary.

EN 15037-1 is a candidate “harmonized” European standard and fully takes into account the requirements of the European Commission mandate M/100, Precast concrete products, given under the EU Construction Products Directive (89/106/EEC), and is intended to lead to CE marking. The date of applicability of EN 15037-1 as a harmonized European Standard, i.e. the date after which this standard may be used for CE marking purposes, is subject to an announcement in the *Official Journal of the European Communities*.

EN 15037-1:2008 is the subject of transitional arrangements agreed under the European Commission mandate. Member States have agreed a transition period for the co-existence of BS EN 15037-1:2008 and its corresponding national standard(s). It is intended that this period will comprise a period, usually nine months, after the date of availability of the European Standard, during which any required changes to national regulations are to be made, followed by a further period, usually of 12 months, for the implementation of CE marking. At the end of this co-existence period, the national standard(s) will be withdrawn. In the UK, there are no corresponding national standards of national origin.

This publication does not purport to include all the necessary provisions of a contract. Users are responsible for its correct application.

Compliance with a British Standard cannot confer immunity from legal obligations.

This British Standard was published under the authority of the Standards Policy and Strategy Committee on 30 June 2008

© BSI 2008

ISBN 978 0 580 54648 8

Amendments/corrigenda issued since publication

Date	Comments

EUROPEAN STANDARD

EN 15037-1

NORME EUROPÉENNE

EUROPÄISCHE NORM

April 2008

ICS 91.100.30

English Version

Precast concrete products - Beam-and-block floor systems - Part 1: Beams

Produits préfabriqués en béton - Systèmes de planchers à
poutrelles et entrevous - Partie 1: Poutrelles

Betonfertigteile - Balkendecken mit Zwischenbauteilen -
Teil 1: Balken

This European Standard was approved by CEN on 30 June 2007.

CEN members are bound to comply with the CEN/CENELEC Internal Regulations which stipulate the conditions for giving this European Standard the status of a national standard without any alteration. Up-to-date lists and bibliographical references concerning such national standards may be obtained on application to the CEN Management Centre or to any CEN member.

This European Standard exists in three official versions (English, French, German). A version in any other language made by translation under the responsibility of a CEN member into its own language and notified to the CEN Management Centre has the same status as the official versions.

CEN members are the national standards bodies of Austria, Belgium, Bulgaria, Cyprus, Czech Republic, Denmark, Estonia, Finland, France, Germany, Greece, Hungary, Iceland, Ireland, Italy, Latvia, Lithuania, Luxembourg, Malta, Netherlands, Norway, Poland, Portugal, Romania, Slovakia, Slovenia, Spain, Sweden, Switzerland and United Kingdom.



EUROPEAN COMMITTEE FOR STANDARDIZATION
COMITÉ EUROPÉEN DE NORMALISATION
EUROPÄISCHES KOMITEE FÜR NORMUNG

Management Centre: rue de Stassart, 36 B-1050 Brussels

Contents

Page

The numbering of clauses is strictly related to EN 13369: *Common rules for precast concrete products*, at least for the first three digits. When a clause of EN 13369 is not relevant or included in a more general reference of this standard, its number is omitted and this may result in a gap on numbering.

Foreword.....	4
Introduction	6
1 Scope	7
2 Normative references	7
3 Terms and definitions	7
4 Requirements	10
4.1 Material requirements	10
4.2 Production requirements	11
4.3 Finished product requirements	16
5 Test methods.....	24
5.1 Tests on concrete	24
5.2 Measuring of dimensions and surface characteristics	24
5.3 Weight of the products.....	25
5.4 Prestressing	25
6 Evaluation of conformity.....	26
6.1 General.....	26
6.2 Type testing.....	26
6.3 Factory production control.....	26
7 Marking	26
8 Technical documentation	26
Annex A (normative) Inspection schemes for beams.....	28
A.1 General.....	28
A.2 Process inspection.....	28
A.3 Finished product inspection.....	28
Annex B (informative) Typology of beam-and-block floor systems.....	30
B.1 General.....	30
B.2 Floor systems with cast in-situ structural topping	30
B.3 Floor systems with composite topping	31
B.4 Floor systems with partial topping	32
B.5 Floors with self-bearing beams.....	33
Annex C (informative) Monolithism of composite floor systems	34
C.1 General.....	34
C.2 Strength of connecting reinforcement	36
C.3 Anchorage of connecting reinforcement	36
Annex D (informative) Detailing of supports and anchorage of reinforcement.....	39
D.1 General.....	39
D.2 Construction of supports.....	39
D.3 Anchorage of reinforcements.....	47
Annex E (informative) Design of composite floor systems.....	49
E.1 General.....	49
E.2 Resisting section of the finished floor system.....	49

E.3	Design value of the ULS mid-span bending moment (M_{Rd})	53
E.4	Serviceability limit states	54
E.5	Verification of the shear strength in composite systems	58
Annex F (informative) Design of self-bearing beams		65
F.1	General	65
F.2	Design value of the ultimate limit state bending moment.....	65
F.3	Serviceability limit state of prestressed beams	65
F.4	Design value of the resisting shear force	65
Annex G (informative) Diaphragm action		66
G.1	General	66
G.2	Case of low rise building	67
Annex H (normative) Testing to determine erection spans		68
H.1	General	68
H.2	Determination of erection span	68
H.3	Apparatus	69
H.4	Test arrangement	69
H.5	Loading procedure	70
H.6	Interpretation of results	71
H.7	Test report.....	73
Annex J (informative) Concrete strength at time of release of tendons		74
J.1	General	74
Annex K (informative) Resistance to fire		76
K.1	General	76
K.2	Fire resistance of beam-and-block floor systems	76
K.3	Determination by testing	76
K.4	Evaluation by calculation	76
K.5	Tabulated data	78
Annex L (informative) Acoustic insulation		79
L.1	General	79
L.2	Airborne sound insulation.....	79
L.3	Impact sound insulation	79
Annex Y (informative) Choice of CE marking method.....		81
Y.1	General	81
Y.2	Method 1	81
Y.3	Method 2.....	81
Y.4	Method 3.....	81
Annex ZA (informative) Relationship between this European Standard and the Essential Requirements of EU Directive 89/109/EEC, EU Construction Products Directive.....		82
ZA.1	Scope and relevant characteristics	82
ZA.2	Procedure for attestation of conformity of beams for beam-and-block floor systems	84
ZA.3	CE marking and labelling	85

Foreword

This document (EN 15037-1:2008) has been prepared by Technical Committee CEN/TC 229 “Precast concrete products”, the secretariat of which is held by AFNOR, and was examined by and agreed with a joint working party appointed by the Liaison Group CEN/TC 229-TC 250, particularly for its compatibility with structural Eurocodes.

This European Standard shall be given the status of a national standard, either by publication of an identical text or by endorsement, at the latest by October 2008, and conflicting national standards shall be withdrawn at the latest by April 2011.

This document has been prepared under a mandate given to CEN by the European Commission and the European Free Trade Association, and supports essential requirements of EU Directive(s).

For relationship with EU Directive(s), see informative Annex ZA, which is an integral part of this document.

European Standard for beam-and-block floor system is made of 5 parts:

- EN 15037-1, *Precast concrete products - Beam-and-block floor systems — Part 1: Beams*
- prEN 15037-2, *Precast concrete products - Beam-and-block floor systems — Part 2: Concrete blocks¹⁾*
- prEN 15037-3, *Precast concrete products - Beam-and-block floor systems — Part 3: Clay blocks¹⁾*
- prEN 15037-4, *Precast concrete products - Beam-and-block floor systems — Part 4: Polystyrene blocks¹⁾*
- prEN 15037-5, *Precast concrete products - Beam-and-block floor systems — Part 5: Lightweight blocks¹⁾*

This standard is one of a series of product standards for precast concrete products.

For common aspects reference is made to EN 13369: *Common rules for precast concrete products*, from which also the relevant requirements of the EN 206-1: *Concrete — Part 1: Specification, performance, production and conformity* are taken.

The references to EN 13369 by CEN/TC 229 product standards are intended to make them homogeneous and to avoid repetitions of similar requirements.

Eurocodes are taken as a common reference for design aspects. The installation of some structural precast concrete products is dealt with by ENV 13670-1: *Execution of concrete structures — Part 1: Common rules*, which has at the moment the status of a European Prestandard. In all countries it can be accompanied by alternatives for national application and it should not be treated as a European Standard.

The program of standards for structural precast concrete products comprises the following standards, in some cases consisting of several parts:

EN 1168, *Precast concrete products — Hollow core slabs*

EN 12794, *Precast concrete products — Foundation piles*

EN 12843, *Precast concrete products — Masts and poles*

1) to be developed

- EN 13224, *Precast concrete products — Ribbed floor elements*
- EN 13225, *Precast concrete products — Linear structural elements*
- EN 13693, *Precast concrete products — Special roof elements*
- EN 13747, *Precast concrete products — Floor plates for floor systems*
- EN 13978, *Precast concrete products — Precast concrete garages*
- EN 14843, *Precast concrete products — Stairs*
- EN 14844, *Precast concrete products — Box culverts*
- EN 14991, *Precast concrete products — Foundation elements*
- EN 14992, *Precast concrete products — Wall elements*
- EN 15050, *Precast concrete products — Bridge elements*
- prEN 15258, *Precast concrete products — Retaining wall elements*

This standard defines in Annex ZA the application methods of CE marking to products designed using the relevant EN Eurocodes (EN 1992-1-1:2004 and EN 1992-1-2:2004). Where, in default of applicability conditions of EN Eurocodes to the works of destination, design Provisions other than EN Eurocodes are used for mechanical strength and/or fire resistance, the conditions to affix CE marking to the product are described in ZA.3.4.

According to the CEN/CENELEC Internal Regulations, the national standards organizations of the following countries are bound to implement this European Standard: Austria, Belgium, Bulgaria, Cyprus, Czech Republic, Denmark, Estonia, Finland, France, Germany, Greece, Hungary, Iceland, Ireland, Italy, Latvia, Lithuania, Luxembourg, Malta, Netherlands, Norway, Poland, Portugal, Romania, Slovakia, Slovenia, Spain, Sweden, Switzerland and United Kingdom.

Introduction

The evaluation of conformity given in this standard refers to the completed precast elements which are supplied to the market and covers all the production operations carried out in the factory.

For design rules reference is made to EN 1992-1-1:2004. Additional complementary rules are provided where necessary.

Recommendations for beam-and-block floor systems are presented in informative annexes about monolithism of composite floor systems (Annex C), detailing of supports and anchorage reinforcement (Annex D), design of composite floor systems (Annex E), design of self-bearing beams (Annex F), diaphragm action (Annex G), resistance to fire (Annex K) and acoustic insulation (Annex L).

According to 1.2 of EN 1992-1-1:2004 the complementary rules, given in informative annexes in this standard, comply with the relevant principles given in EN 1992-1-1.

Because of the fact that the experimental evidence is mainly based on elements with limited depth and width this standard is applicable to elements with these limited dimensions. This limitation is not intended to prohibit the application of elements with larger sizes, but the experience is not yet wide enough to draw up standardised design rules.

In 4.2.3, 4.3.2, 4.3.3 and 4.3.4, this standard includes specific provisions resulting from the application of EN 1992-1-1:2004 and EN 1992-1-2:2004 rules made specific for the concerned product. The use of these provisions is consistent with a design of works made with EN 1992-1-1:2004 and EN 1992-1-2:2004.

1 Scope

This European Standard deals with the requirements, the basic performance criteria and evaluation of conformity for precast beams made of reinforced or prestressed normal weight concrete according to EN 1992-1-1:2004, with or without clay shell, used in conjunction with blocks in compliance with prEN 15037-2 or prEN 15037-3 or prEN 15037-4 or prEN 15037-5, with or without cast in-situ concrete for the construction of beam-and-block floor and roof systems. Examples of typology of floor and roof systems are given in Annex B.

It is essential that the total depth of the beam be comprised between 60 mm and 500 mm and the beams be at centres of not more than 1,00 m.

For higher depth, it is essential that the precast concrete beams be in compliance with EN 13225.

The products covered by this standard are intended to be used as structural floor and roof systems, including parking areas for light vehicles corresponding to traffic category F of EN 1991-1-1:2002, which are not subjected to fatigue loading.

The products may be used in seismic areas provided they fulfil the requirements specific to this use.

2 Normative references

The following referenced documents are indispensable for the application of this document. For dated references, only the edition cited applies. For undated references, the latest edition of the referenced document (including any amendments) applies.

EN 1990:2002, *Eurocode — Basis of structural design*

EN 1992-1-1:2004, *Eurocode 2: Design of concrete structures — Part 1-1: General rules and rules for buildings*

EN 1992-1-2:2004, *Eurocode 2: Design of concrete structures — Part 1-2: General rules — Structural fire design*

EN 10080:2005, *Steel for the reinforcement of concrete — Weldable reinforcing steel — General*

EN 12390-4:2000, *Testing hardened concrete — Part 4: Compressive strength — Specification for testing machines*

EN 13369:2004, *Common rules for precast concrete products*

prEN 15037-2, *Precast concrete products — Beam-and-block floor systems — Part 2: Concrete blocks*

prEN 15037-3, *Precast concrete products — Beam-and-block floor systems — Part 3: Clay blocks*

3 Terms and definitions

For the purposes of this document, the terms and definitions given in EN 13369:2004 and the following apply.

3.1

beam

linear structural element of small cross-sectional area, made of reinforced concrete or prestressed concrete, entirely or partially precast

NOTE It may include elements which may or may not contribute to its strength (e.g. clay lower toe, clay shells) as shown in Figure 1

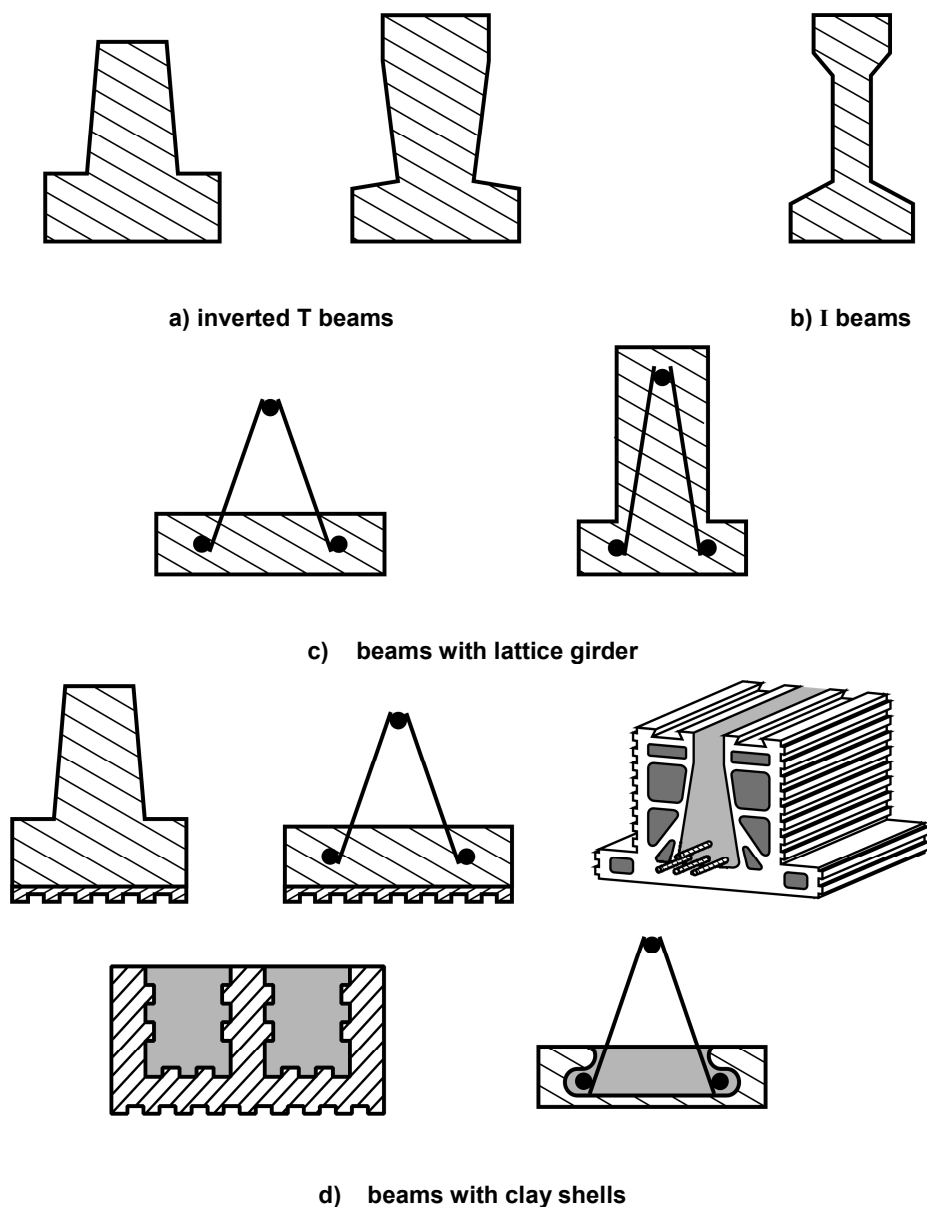

Figure 1 — Examples of beams

3.2 prestressed concrete beam
beam prestressed by pretensioning of prestressing steel which constitute the main reinforcement of the floor system

3.3 reinforced concrete beam
beam whose longitudinal reinforcement made of reinforcing steel constitutes the main reinforcement of the floor system

3.4 self-bearing beam
reinforced or prestressed concrete beam which provides the final strength of the floor system independently of any other constituent part of the floor system

3.5

non self-bearing beam

reinforced or prestressed concrete beam which provides the final strength of the floor in conjunction with cast in-situ concrete, and possibly with blocks

3.6

block

elements placed between beams made of normal weight or lightweight concrete, clay, polystyrene, plastic or wood composite (see also prEN 15037-2, prEN 15037-3, prEN 15037-4 and prEN 15037-5)

3.7

connecting reinforcement

reinforcement anchored on both sides of the interface between the beam and the cast in-situ concrete

NOTE It may consist of the diagonals of lattice girder, individual or continuous reinforcement in the form of loops, possibly with a longitudinal bar welded at the top and/or bottom (see Figure 2)

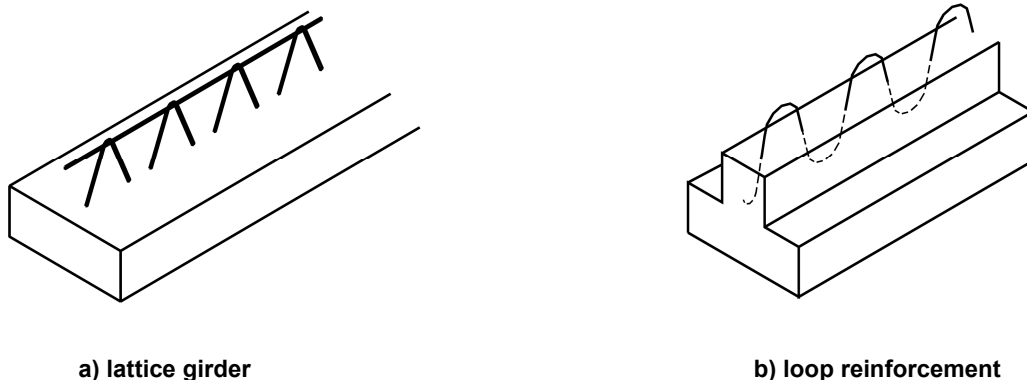

Figure 2 — Examples of connecting reinforcement

3.8

shear reinforcement

reinforcement with angle generally between 45° and 90° to the longitudinal axis of the beams

NOTE It is said to be "internal" if it provides only resistance to the shear force of the beam alone. In practice it consists of lattice girders, loop reinforcement, stirrups, etc.

3.9

lattice girder

two dimensional or three dimensional metallic structure comprising an upper chord, one or more lower chords and continuous or discontinuous diagonals which are welded or mechanically connected to the chords

NOTE Figure 3 gives some examples of lattice girders

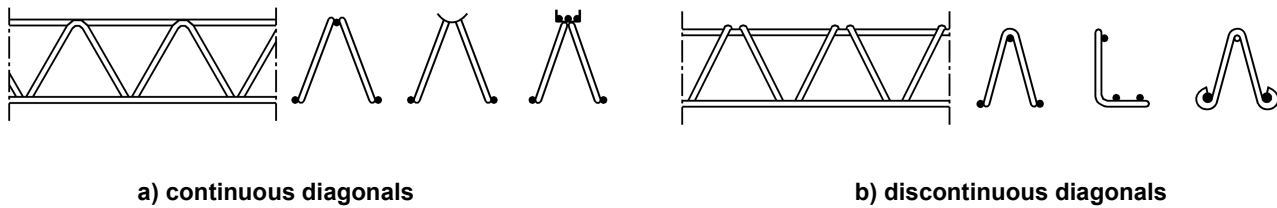

Figure 3 — Examples of lattice girders

3.10 beam-and-block floor system

floor made from a combination of parallel beams with blocks placed between them, and possibly with a cast in-situ topping which may or may not act as a compression slab

3.11 compression slab

compressed upper flange of a section of structural floor

NOTE It could be a distribution slab connected to the ribs or a topping by considering the upper part of the rib and the top flange of the resisting blocks

3.12 distribution slab

reinforced monolithic concrete slab cast in situ over the whole floor surface, in order to spread the concentrated loads over the ribs or to ensure the bending of the slab between ribs

4 Requirements

4.1 Material requirements

4.1.1 General

4.1.1 of EN 13369:2004 shall apply.

4.1.2 Constituent materials of concrete

4.1.2 of EN 13369:2004 shall apply.

4.1.3 Reinforcing steel

4.1.3.1 Bars, coils and welded mesh

4.1.3 of EN 13369:2004 shall apply.

4.1.3.2 Lattice girders

Lattice girder shall comply with EN 10080.

4.1.3.3 Connecting reinforcement

Connecting reinforcement, other than lattice girder, shall be ribbed, indented or smooth steel complying with their relevant standards. Where its suitability can be proven prestressing wires or strands can be used.

Their diameter shall be comprised from 4 mm to 8 mm inclusive.

4.1.4 Prestressing steel

4.1.4 of EN 13369:2004 shall apply.

Only tendons (wires or strands) with a diameter less than 13 mm shall be used.

NOTE Other prestressing steel according to national requirements may be used until European specifications are available.

4.1.5 Inserts and connectors

4.1.5 of EN 13369:2004 shall apply.

4.2 Production requirements

4.2.1 Concrete production

4.2.1 of EN 13369:2004 shall apply

NOTE For reinforced concrete beams, the values given in Table 1 of EN 13369:2004 may be reduced with a minimum compressive cylinder strength of 4 MPa at the end of curing.

4.2.2 Hardened concrete

4.2.2.1 Strength classes

4.2.2.1 of EN 13369:2004 shall apply.

4.2.2.2 Compressive strength

4.2.2.2 of EN 13369:2004 shall apply. In addition, the minimum concrete compressive strength on delivery shall not be less than 20 MPa for reinforced beams and 25 MPa for prestressed beams.

NOTE For prestressed concrete beams for which the minimum concrete strength required at time of release is given, it is not necessary to check the strength of the concrete on the delivery date.

The concrete class shall not be less than C25/30 for reinforced beams and C30/37 for prestressed beams.

4.2.3 Structural reinforcement

4.2.3.1 Processing of reinforcing steel

4.2.3.1 of EN 13369:2004 shall apply.

4.2.3.2 Tensioning and prestressing

4.2.3.2.1 Initial tensioning stresses

4.2.3.2.1 of EN 13369:2004 shall apply.

4.2.3.2.2 Accuracy of tensioning

4.2.3.2.2 of EN 13369:2004 shall apply.

4.2.3.2.3 Minimum concrete strength at time of release

At the time of release of prestressing, the minimum compressive strength, $f_{cmin,p}$, shall be at least $(5/3) \sigma_{cp}$ where σ_{cp} is the compressive stress developed in the bottom fibre of the beam under the final prestressing force, or 20 MPa, whichever is the greater.

Minimum concrete strength at time of release shall be verified in accordance with 5.1.

4.2.3.2.4 Slippage of tendons

Complementary to 4.2.3.2.4 of EN 13369:2004, the maximum slippage values for protruding tendons should be deduced from Table 1. If the initial prestressing force, σ_0 , is lower than the maximum prestressing force, σ_{0max} , as defined in 4.2.3.2.1 of EN 13369:2004, the values of Table 1 shall be reduced by σ_0 / σ_{0max} ratio.

Table 1 — Maximum slippage values for protruding tendons, ΔL_o , in mm

Wires			Strands		
diameter	$f_{cmin,p} = 20 \text{ MPa}$	$f_{cmin,p} = 30 \text{ MPa}$	diameter	$f_{cmin,p} = 20 \text{ MPa}$	$f_{cmin,p} = 30 \text{ MPa}$
Ø 4	2,0	2,0	Ø 5,2	2,5	2,5
Ø 5	2,2	2,0	Ø 6,85	2,8	2,5
Ø 6	2,4	2,0	Ø 9,3	3,0	2,5
Ø 7	2,6	2,3	Ø 12,5	3,5	3,0

NOTE “Good” bond conditions are obtained for extruded, slipformed or moulded elements. For the description of “good” and “poor” bond conditions, Figure 8.2 of EN 1992-1-1:2004 applies.

Slippage of tendons shall be verified in accordance with 5.4.2.

4.2.3.2.5 Limit values for prestressing force

The value of the prestressing force is limited by the following two conditions:

a) Minimum prestress

Under the single action of the final prestressing force, the average prestress cross section shall be no less than 2 MPa and the prestress at the bottom fibre shall be at least 4 MPa.

b) Maximum prestress

The maximum tensile stress in the upper fibre of the concrete as a result of the action of the prestressing force and the dead weight of the beam shall be limited.

NOTE A value of $0,30 f_{cmin,p}^{2/3}$ may be used, where $f_{cmin,p}$ is the strength of the concrete at time of release.

The minimum compressive stress shall be verified according to 4.2.3.2.3.

4.2.3.2.6 Losses of prestress

The final prestressing force, $P_{m,\infty}$, is equal to the initial prestressing force, P_o , less the total losses ΔP after an infinite time.

For the determination of prestressing losses, in the absence of more accurate calculation, the values should be deduced from Table 2.

Table 2 — Final losses of prestress

Initial stress in the tendons (σ_{0max})	Final losses at infinite time in percentage of initial prestress force (ΔPIP_0 %)
min (0,85 f_{pk} ; 0,95 $f_{p0,1k}$)	22 %
0,80 f_{pk}	21 %
0,75 f_{pk}	20 %
0,70 f_{pk}	19 %
0,65 f_{pk}	17 %

4.2.4 Positioning of reinforcement

4.2.4.1 Transfer of bond stress

When a clay toe or a clay shell is present, the distance between the outer surface of the longitudinal reinforcement and the nearest internal face of the clay unit shall not be less than the values given below:

- \varnothing mm or 5 mm (whichever is the greater) for prestressed reinforcement;
- \varnothing mm or 8 mm (whichever is the lesser) for ordinary reinforcement;

where \varnothing is the bar diameter.

4.2.4.2 Correct concreting and compaction of the concrete

Unless it can be justified otherwise, the nominal clear spacing between bars or bundles of bars constituting the main reinforcement shall be at least equal to those as shown in Figure 4, where d_g is the maximum size of aggregate.

For beams with clay shells, the external shape of the beams corresponds to the internal shape of the ceramic shells.

Nominal dimensions in millimetres

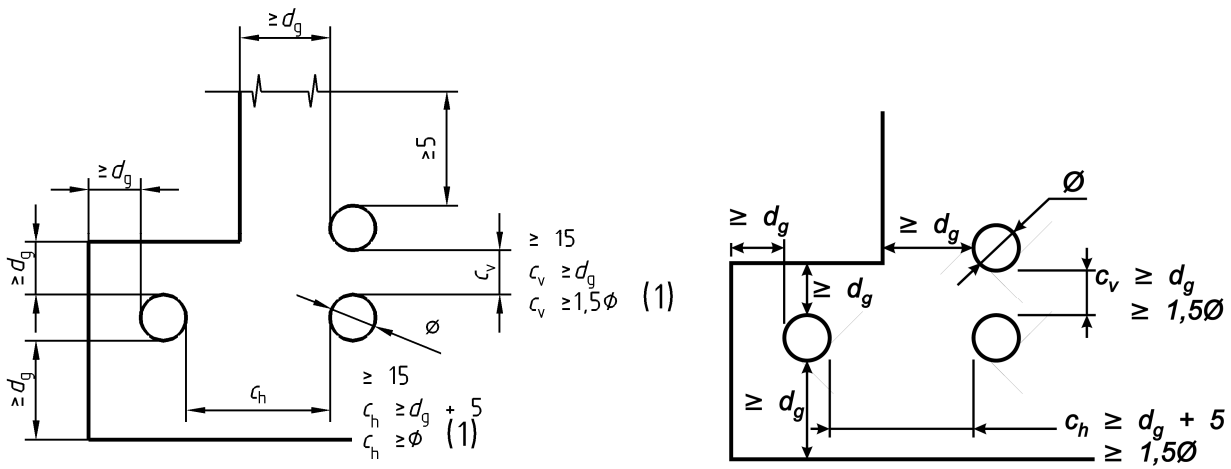

a) reinforced beam

b) prestressed beam

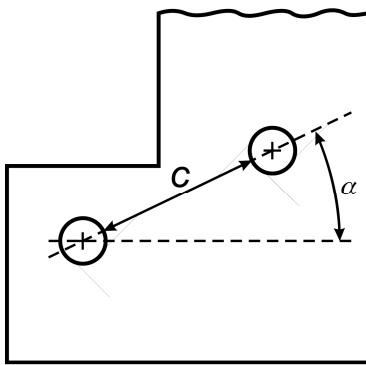

$$c \geq c_v \text{ if } \alpha \geq 45^\circ$$

$$c \geq c_h + 5 \text{ mm if } \alpha < 45^\circ$$

c) reinforced and prestressed beams

Key

(1) diameter of the maximum reinforcement

Figure 4 — Nominal clear spacing for good concreting and compaction

In order to ensure adequate compaction of the topping around connecting reinforcement, the free distance between the upper surface of the beam and the underside of loops or stirrups shall not be less than 35 mm. If there is a longitudinal bar welded to the top of the loops or stirrups, this distance should be reduced to 20 mm (see Figure 5).

Nominal dimensions in millimetres

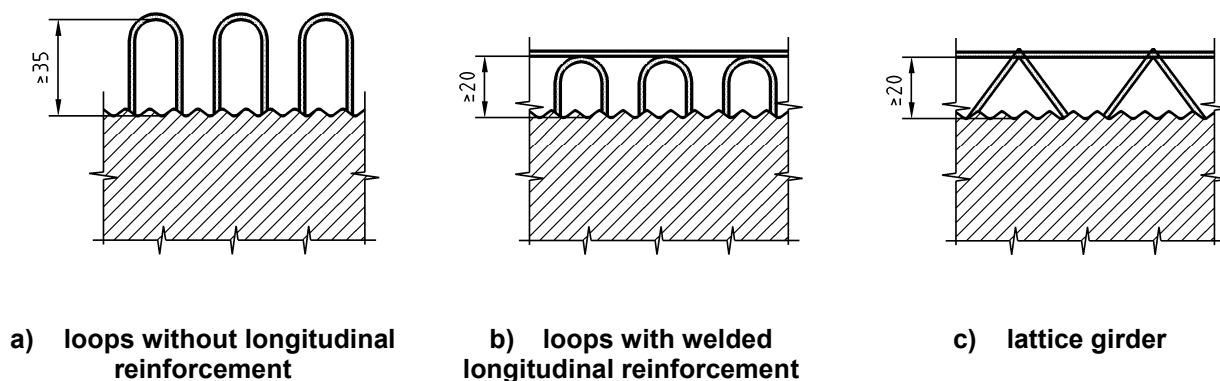

Figure 5 — Positioning of connecting reinforcement for good concreting and compaction

4.2.4.3 Particular requirements for connecting and shear reinforcement

When connecting or shear reinforcement is used:

- legs or diagonals of connecting reinforcement shall be made of smooth, indented or ribbed steel;
- nominal diameter of legs or diagonals of connecting or shear reinforcement shall be comprised between 4 mm and 8 mm inclusive;
- manufacturer shall declare on the basis of a calculation or by testing the pull out strength of the connecting reinforcement in the concrete of the beam;
- welded joint strength shall be guaranteed;
- under justifications, the connecting or shear reinforcement may also be made of prestressing wires by limiting the tensile strength at 500 Mpa.

4.2.4.4 Particular requirements for positioning of prestressing tendons

A minimum distance c_{min} shall be maintained between the outer edge of pretensioned prestressing tendons and the closest concrete surface so as to prevent the risk of longitudinal cracking of the beams.

In the absence of specific calculations or tests, the minimum concrete cover c_{min} between the outer edge of the tendon and the closest concrete surface shall be at least (see Figure 6):

- when the nominal centre to centre distance of the strands $\geq 3 \varnothing$: $c_{min} = 1,5 \varnothing$
- when the nominal centre to centre distance of the strands $\leq 2,5 \varnothing$: $c_{min} = 2,5 \varnothing$

c_{min} should be derived by linear interpolation between the previous calculated values.

NOTE 1 If different reinforcement diameters are used, the average diameter for condition on nominal axes is taken into account for the centre distance.

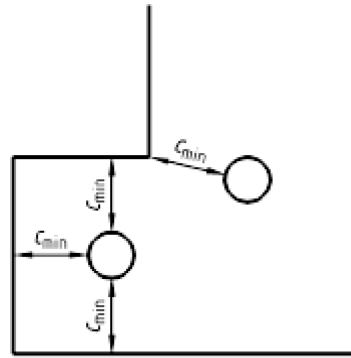

Figure 6 — Minimum dimension to prevent cracking of concrete of prestressed beams

NOTE 2 When a clay toe or a clay shell is present, and if the bottom part of the joints between the clay elements are filled in with concrete effectively, a x mm of clay thickness may be considered equivalent to a concrete cover equal to x mm (for active and passive reinforcement).

4.3 Finished product requirements

4.3.1 Geometrical properties

4.3.1.1 General

Complementary to 4.3.1 of EN 13369:2004, next subclauses shall apply.

For technical documentation see Clause 8.

4.3.1.2 Production tolerances

4.3.1.2.1 General

The maximum deviations, measured in accordance with 5.2, on the specified nominal dimensions shall satisfy the following requirements.

4.3.1.2.2 Dimensional tolerances

- a) nominal concrete length: ± 25 mm
- b) nominal depth h :
 - $(- 5 ; + 10)$ mm if $h \leq 100$ mm
 - $(- 5h / 100 ; + 10)$ mm if $100 \leq h \leq 200$ mm
 - $(- 10 ; + 10)$ mm if $200 \leq h \leq 500$ mm
- c) width of the toe: ± 5 mm
- d) other transverse dimensions:
 - self-bearing beams and non self-bearing beams without overhang: $(- 5 ; + 10)$ mm
 - non self-bearing beams with overhang: $(- 5 ; + 5)$ mm

NOTE The conditions for considering a beam with overhang are given in Table 3 (type c_{2b}).

e) straightness of prestressed beam in the horizontal plane: $\leq 1/250^{\text{th}}$ of this concrete length

4.3.1.2.3 Tolerances in the positioning of reinforcement

a) Passive longitudinal reinforcement:

- position in the transverse section: vertically: ± 5 mm on individual reinforcement
- longitudinal position: ± 15 mm
- protruding length: $[- 20 \text{ mm} ; + 50 \text{ mm}]$

NOTE The tolerance on the longitudinal position may be increased if specific provisions guarantee an equivalent level of safety.

b) Prestressed reinforcement

- position in the transverse section: vertically: $\pm \text{MIN}[5\% h_c; 10 \text{ mm}]$ on individual reinforcement
 $\pm \text{MAX}[h_c/40; 3 \text{ mm}]$ on the centre of gravity of prestressed reinforcement
with h_c the concrete height of the beam excluding lattice girder (see Figure 7)
- horizontally: ± 10 mm on individual reinforcement
- protruding length: $[- 20 \text{ mm} ; + 50 \text{ mm}]$

c) Transverse reinforcement (connecting and shear reinforcement)

- position in the transverse section: vertically: ± 10 mm
horizontally: ± 10 mm on individual reinforcement
- longitudinal position: ± 30 mm

4.3.1.3 Minimum dimensions

Complementary to 4.3.1.2 of EN 13369:2004, next subparagraphs shall apply. The dimensions shall be verified according to 5.2.2.

a) Depth

- self-bearing beams: $100 \text{ mm} \leq h \leq 500 \text{ mm}$
- non self-bearing beams: $70 \text{ mm} \leq h \leq 500 \text{ mm}$
- non self-bearing beams without lattice girder and without web: $h \geq 60 \text{ mm}$

b) Widths

- bottom width: $b_o \geq 85 \text{ mm}$
- web width: $b_w \geq 40 \text{ mm}$

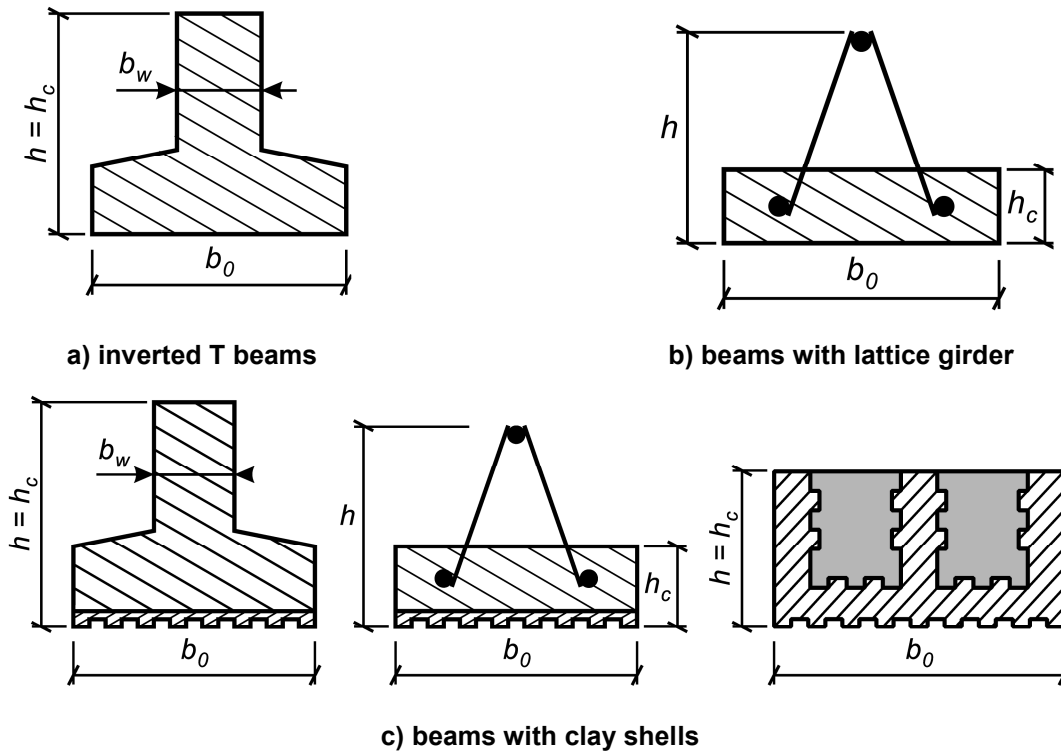

Figure 7 — Definitions of beam dimensions

c) Dimensions of toe rebate (see Figure 8)

- bearing surface: $b_f \geq 20$ mm
- thickness: $h_f \geq \text{Max} [0,9 b_f ; 30 \text{ mm}]$
- angle: $\alpha_f \leq 35^\circ$

Nominal dimensions in millimetres

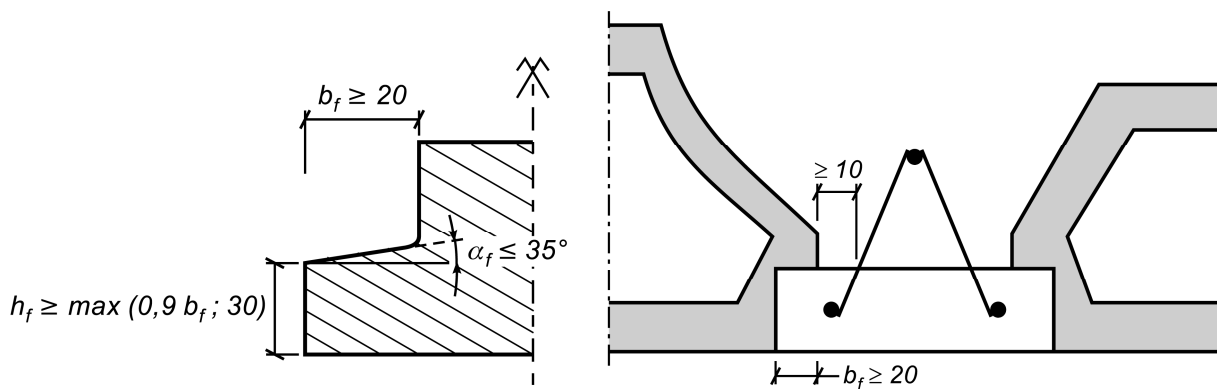

Figure 8 — Dimensions of toe rebate

NOTE The distance of 10 mm between the nib of the block and the diagonal of the lattice girder is given as a minimum value (cover).

4.3.2 Surface characteristics

4.3.2.1 Toe rebate

Bearing surfaces of the beams receiving the blocks shall be even.

NOTE If clay toes are placed on the concrete lower face at the time of manufacture, the clay may be grooved to allow for bonding.

4.3.2.2 Upper surface and sides

In order to take into account the bond between beams and the cast in-situ concrete in the monolithism check of composite floor system made of non self-bearing beams (see Annex C), the surface characteristics of the interface of beams with the cast in-situ concrete shall be declared and guaranteed.

This surface shall be clean and free of any debris that could be detrimental to the bonding. It shall be verified in accordance with 5.2.3.

The beams with clay shells shall have a rough concrete part and a strongly grooved clay part.

Table 3 gives, in relation to the different surface conditions for prestressed beams which are currently obtained in practice, the design value of the shear stress at the interface corresponding to ultimate limit state $k_1 v_{Rdi}$ and the value of the friction coefficient $k_2 \mu$, where the recommended values of $k_1 = k_2 = 1,0$ have been assumed.

Table 3 — Surface conditions for prestressed beams (top and sides)

Type	Beam surface condition	Values for v_{Rdi} (MPa)			μ
		In situ concrete classes			
		C20/25	C25/30	\geq C30/37	
c_1	<p>— The top and sides of the beam are slipformed or extruded (no overhang)</p> 	0,41	0,48	0,54	0,6
c_{2a}	<p>— The top of the beam is rough (surface with at least 3 mm roughness at no more than 20 mm spacing), or transversally grooved or corrugated. The sides of the beam are moulded, slipformed or extruded (no overhang)</p>  <p>— For clay beams with web, the sides are grooved and the depth of the floor is equal to the height of the beam</p> 	0,46	0,55	0,63	0,7
c_{2b}	<p>— The top and sides of the beam are slipformed or extruded and are tapered towards the flange with an overhang greater than 4 mm and an angle of at least 6 % over a height greater than 2/3 of the effective depth of the bond h_u</p> 				
c_{3a}	<p>— The beam is as described in c_{2b} and the top is rough as defined in c_{2a}</p> 	0,58	0,69	0,79	0,8

Table 3 (continued)

Type	Beam surface condition	Values for ν_{Rdi} (MPa)			μ
		In situ concrete classes			
		C20/25	C25/30	\geq C30/37	
c_{3a}	<p>— For clay beams with web, the top is rough as defined in c_{2a}, the sides are grooved and the floor is complemented by a topping.</p> <p>— For clay beams without web where the top is rough as defined in c_{2a}</p> 	0,58	0,69	0,79	0,8
c_{3b}	<p>— The transverse section is similar to the shape described in c_{2b}. The top and sides of the beam are untreated, and the surfaces of the sides have a floated appearance</p>				
c_4	<p>— The beam is as described in c_{3b} and the top is rough as defined in c_2</p>	0,60	0,75	0,83	0,8
c_5	<p>— The top and sides of the beam are transversally indented as defined in 6.2.5 of EN 1992-1-1:2004</p> 	0,60	0,75	0,90	0,9

NOTE 1 For the verification in accidental situations, the values of ν_{Rdi} may be increased by 25 %.

NOTE 2 Clay elements (beams and blocks) may be dampened just before pouring in-situ concrete.

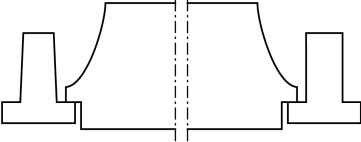
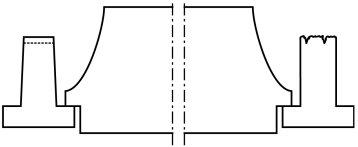
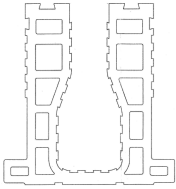
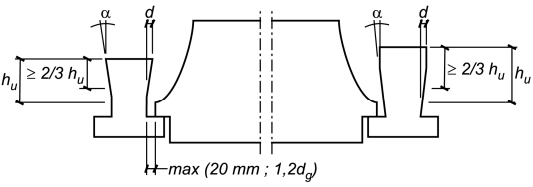
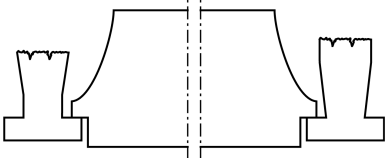
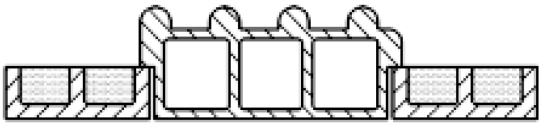
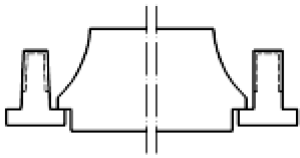
4.3.3 Mechanical resistance

4.3.3.1 General

4.3.3.1 of EN 13369:2004 shall apply.

For Technical Documentation see Clause 8.

4.3.3.2 Verification by calculation

4.3.3.2 of EN 13369:2004 shall apply.

4.3.3.3 Verification by calculation aided by physical testing

Complementary to 4.3.3.3 of EN 13369:2004, the following requirements shall apply.

For transient situations, the design model used to calculate the capacity of reinforced or prestressed concrete beams shall be initially validated by tests.

For confirmation of design model, a test method is given in Annex H.

After the confirmation of design model, monitoring tests on beams shall be carried out, with the same procedure as the initial type testing. The beams shall be calculated with the hypothesis given in H.2.

For beams deeper than 150 mm the monitoring tests may be avoided if the design model used in calculation includes the geometrical tolerances.

4.3.3.4 Verification by testing

Not relevant.

4.3.3.5 Safety factors

4.3.3.5 of EN 13369:2004 shall apply.

4.3.3.6 Transient situations

Complementary to 4.3.3.6 of EN 13369:2004, the following requirements shall apply.

The transient situations covered by this sub-clause relate to storage, handling, transport and installation.

The strength and properties of the concrete beam to be considered in transient situations are those specified by the manufacturer at the time of delivery.

The effective support lengths, the distances between the bearing supports and between the temporary supports (e.g. props), together with the loads taken into account in determining them, shall be declared.

The technical documentation shall provide the recommended installation drawings.

The methods of storage and transportation, and the position of bearing points shall be indicated on documentation provided.

The position of lifting points shall be determined for limiting the tensile stress to appropriate values under the action of the self weight of the beam multiplied by a dynamic coefficient.

The producer shall indicate the position of lifting points (examples are given in Figure 9).

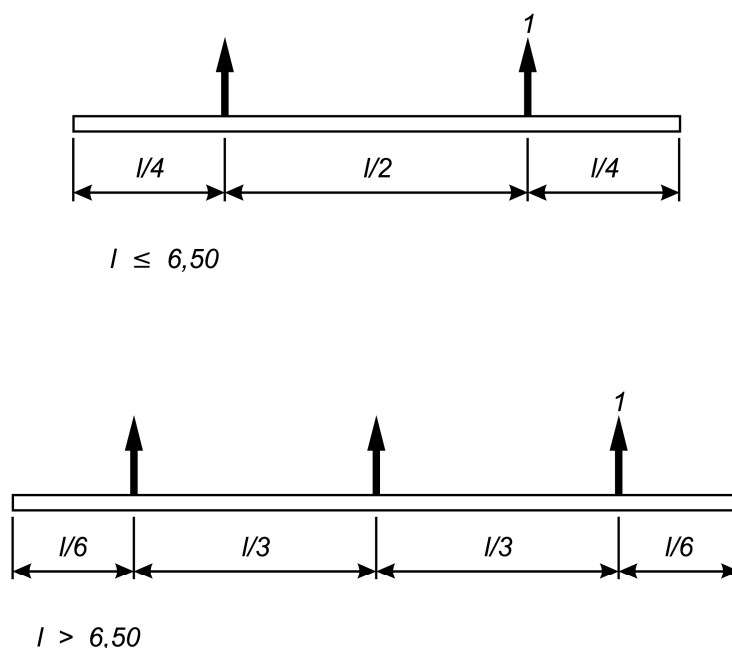

Key

1 Lifting points

Figure 9 — Examples of positions of lifting points

4.3.4 Resistance and reaction to fire

4.3.4.1 Resistance to fire

Fire resistance, dealing with load-bearing capacity of beams for beam-and-block floor systems, expressed in terms of classes, shall be declared following 4.3.4.1 to 4.3.4.3 of EN 13369:2004.

NOTE 1 For the verification of standard fire resistance by testing, EN 1365-2 should apply. The method given in Annex K may be used to determine the fire-resistance of the floor system.

NOTE 2 The fire design of the floor system may be given by the manufacturer in the technical documentation (see Clause 8).

4.3.4.2 Reaction to fire

4.3.4.4 of EN 13369:2004 shall apply

4.3.5 Acoustic properties

4.3.5 of EN 13369:2004 shall apply.

NOTE Acoustic performances depend on the finished floor system (type of blocks, applied elements in upper and/or lower face of the floor, etc.). For design purposes, the airborne and impact sound insulation may, in the absence of test results, be estimated according to Annex L.

4.3.6 Thermal properties

4.3.6 of EN 13369:2004 shall apply.

NOTE Thermal performances depend on the finished floor system (type of blocks, applied elements in upper and/or lower face of the floor, etc.).

4.3.7 Durability

Complementary to 4.3.7 of EN 13369:2004, the following requirements may apply.

Referring to the exposure classes, the minimum distance between the surface of the reinforcement and the exposed face of the beam in the structural part of the floor (lower face), may comply with the values given for slabs in Table A.2 of EN 13369:2004.

The minimum distance between the surface of the reinforcement and the non-exposed face may comply with the exposure class B, according to Annex A of EN 13369:2004. When the beam is used in conjunction with concrete blocks or clay blocks, the minimum cover may be reduced for 5 mm.

Alternative conditions described in Annex A of EN 13369:2004 may apply.

Unless otherwise specified, bathrooms in single-family dwellings or apartments and ventilated crawl spaces of buildings may be designed to exposure class B, according to Annex A of EN 13369:2004.

NOTE When a clay toe or a clay shell is present, and if the bottom part of the joints between the clay elements are filled in with concrete effectively, a x mm of clay thickness may be considered equivalent to a concrete cover equal to x mm (for active and passive reinforcement).

4.3.8 Other requirements

4.3.8 of EN 13369:2004 shall apply.

5 Test methods

5.1 Tests on concrete

5.1 of EN 13369:2004 shall apply.

NOTE If the concrete strength at time of release is determined by crushing cube or cylinder specimens, the procedure described in Annex J may be applied.

5.2 Measuring of dimensions and surface characteristics

Complementary to 5.2 of EN 13369:2004, next subclauses shall apply.

5.2.1 Positioning of reinforcement

a) Procedure

The measurements shall be made either on the casting bed, when the product reaches the end of the manufacturing process, or in the storage area.

The following measurements shall be made:

- position of longitudinal reinforcement, including cover;
- length of protrusion of protruding bars;
- position of transverse reinforcement.

The results of measurements shall be recorded.

b) Interpretation of results

The results shall comply with the requirements of 4.2.4 and the tolerance values defined in 4.3.1.2.3.

5.2.2 Beam dimensions

a) Procedure

Measurements shall be taken either when the product reaches the end of the manufacturing process, or in the storage area. The following measurements shall be taken:

- length;
- straightness of prestressed beam;
- cross sectional dimensions.

The measurements shall be recorded.

b) Interpretation of results

The results shall comply with the requirements of 4.3.1 and the values specified by the manufacturer, within the tolerances given in 4.3.1.2.2.

5.2.3 Surface characteristics

If special arrangements (roughness, beam shapes as described in Table 3) are required to establish monolithism between the beams and the cast in-situ concrete, these arrangements shall be subject to appropriate verifications:

- visual inspection of roughness relative to a reference sample;
- dimensional check of the profile.

5.3 Weight of the products

The weight of the products is generally assessed on the basis of the theoretical density and the nominal dimensions of the beams. When the contract requires the measurement of weights, this is carried out in accordance with EN 13369.

5.4 Prestressing

5.4.1 Initial prestressing force

a) Procedure

The prestressing force is determined by measuring force or elongation and checked against each other.

b) Interpretation of results

The tensile force corresponding to measured elongation of the tendon shall be deduced from the "elongation-force" diagram provided by the tendon manufacturer.

The difference between the initial prestressing force obtained by direct measurement of the force and that deduced from measurement of elongation shall be less than 10 %.

The results shall be recorded.

5.4.2 Slippage of tendons

a) Procedure

Independent of the production method, tendon slippage shall be measured by means of an appropriate measuring instrument accurate to within 0,1 mm.

b) Interpretation of results

Slippage shall be limited to the values evaluated in 4.2.3.2.4.

For strands sawn at the ends of the beams, the individual slippage value of the strand is determined by taking the average for three wires (taken on a diagonal) of the strand.

6 Evaluation of conformity

6.1 General

6.1 of EN 13369:2004 shall apply.

6.2 Type testing

6.2 of EN 13369:2004 shall apply.

6.3 Factory production control

6.3 of EN 13369:2004, except 6.3.6.5, shall apply, with the complementary requirements of Annex A.

7 Marking

Clause 7 of EN 13369:2004 shall apply.

Delivered beam shall be uniquely identifiable and traceable until erection with regard to its production site and data. For this purpose the manufacturer shall mark the products or the delivery documents so the relation to the corresponding quality records required in this standard can be secured. The manufacturer shall keep these records for the required period of archiving and make them available when required.

NOTE For CE marking it is recommended to refer to Annex ZA.

8 Technical documentation

The detailing of the element, with respect to geometrical data and complementary properties of materials and inserts, shall be given in technical documentation, which includes the construction data, such as the recommended installation drawings, the dimensions, the tolerances, the layout of reinforcement, the concrete cover, the expected transient and final support conditions and lifting conditions.

The beams shall be used only with blocks for which the compatibility in the final floor system has been demonstrated. The compatibility criteria are indicated in the technical documentation.

The information needed for the designer of the works to design final situations may be given by the manufacturer in the technical documentation.

The design of the floor system may be given by the manufacturer in the technical documentation.

Design recommendations for beam-and-block floor systems are given in informative annexes about monolithism of composite floor systems (Annex C), detailing of supports and anchorage reinforcement (Annex D), design of composite floor systems (Annex E), design of self-bearing beams (Annex F), diaphragm action (Annex G), resistance to fire (Annex K) and acoustic insulation (Annexe L).

The composition of technical documentation is given in Clause 8 of EN 13369:2004.

Annex A (normative)

Inspection schemes for beams

A.1 General

The relevant subjects of Annex D of EN 13369:2004 shall apply. Complementary to these subjects, the following schemes shall also apply.

A.2 Process inspection

Table A.1 is complementary to D.3.2 of Table D.3 of EN 13369:2004.

The manufacturer may choose between potential strength, for which item 1 of Table A.1 shall apply instead of item 8 of Table D.3.1 of EN 13369:2004, or structural strength, for which item 9 of Table D.3.1 of EN 13369:2004 shall apply.

Table A.1 — Process inspection

	Subject	Method	Purpose ^a	Frequency ^a
Concrete				
1	Concrete compressive strength	Strength test on moulded concrete specimens or other methods (see 5.1)	Concrete strength at release of tendons (see 4.2.3.2.3) Strength on delivery (see 4.2.2.2)	Each production day, 3 specimens (at least) shall be made: — 3 specimens for each production unit (hall) and each concrete type if there is no heat treatment — 3 specimens for each casting bed and each concrete type if there is a heat treatment. For lattice girder beams, this frequency may be reduced to once a week.
Other process subjects				
2	Initial prestressing force	Direct measurement of jack force or elongation of tendons (see 5.4.1)	Verification of the stated value	Each production day, on one prestressing tendons per production unit (hall)
^a The indicated tests and frequencies may be adapted or even deleted when equivalent information is obtained directly or indirectly from the product or process.				

A.3 Finished product inspection

Table A.2 is complementary to D.4.1 of Table D.4 of EN 13369:2004.

Table A.2 — Finished product inspection

	Subject	Method	Purpose ^a	Frequency ^a
Product testing				
1	Slippage of tendons	Measuring of slippage for none sawn elements (see 5.4.2) Visual inspection of sawn elements and measuring	Conformity with maximum value (see 4.2.3.2.4)	Each production day, three measurements per bed Visual inspection of the elements and if there is no doubt measuring three strands per production day. In case of doubt measuring of all concerning strands
2	Dimensions: — length — depth — cross section — straightness of edges — cover (positioning of reinforcement) — protruding reinforcement	Measuring according to 5.2.1 and 5.2.2	Conformity with drawing and specified tolerances (see 4.3.1)	Each 5 production days with a minimum of 1 each week, on one beam (at least) taken at random, every time a different type
3	Ends of elements	Visual inspection	Splitting cracks	Each sawn end
4	Surface characteristics: — roughness — general appearance	Visual inspection (see 5.2.3)	Roughness for monolithism (see 4.3.2)	For each bed
5	Beam ^c capacity during transient situations ^b	As described in Annex H (see also 4.3.3.3)	Conformity with the specified requirements of the product standard and with the specified or declared values	On each type of beams ^c , after setting up the first production or if there is a major change in type of lattice girder, or method of manufacture. During production, for beams ^c without lattice girders, at the age upon delivery, once each 20 production days, on a beam of each depth, every time a beam with different types of reinforcement

^a The indicated tests and frequencies may be adapted or even deleted when equivalent information is obtained directly or indirectly from the product or process.

^b Previous tests performed before the date of this standard may be considered if they comply with the requirements of this standard. Test results may be those given by the producer of lattice girders.

^c Not applicable to beams designed according to 4.3.3.2.

Annex B (informative)

Typology of beam-and-block floor systems

B.1 General

The beams are manufactured in factories by moulding, slip-forming, or extrusion. They may be arranged in groups to strength the floor.

The following clauses give recommendations about the proper arrangements of floor systems.

B.2 Floor systems with cast in-situ structural topping

B.2.1 General

Floors with cast in-situ structural topping consist of beams in conjunction with non-resisting blocks or semi-resisting blocks as they are defined in prEN 15037-2, prEN 15037-3, prEN 15037-4, prEN 15037-5, and with cast in-situ concrete constituting the compression slab of the finished floor system (see Figure B.1).

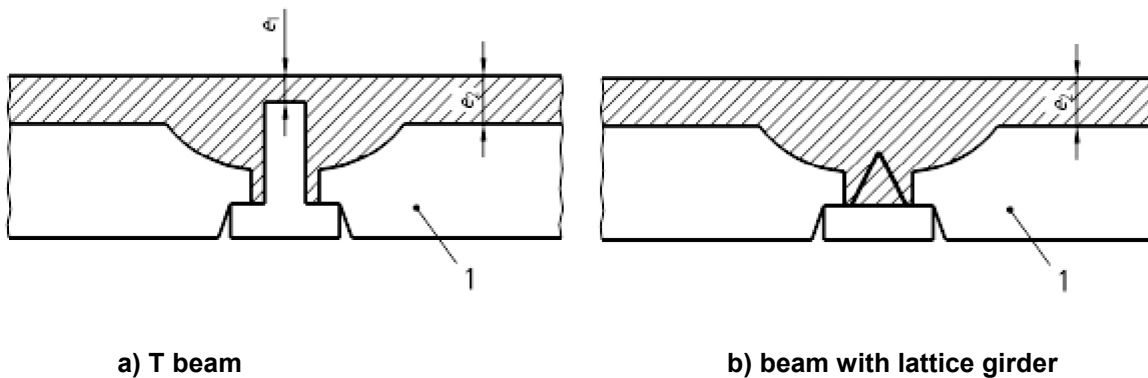

Key

1 Non-resisting or semi-resisting blocks

Figure B.1 — Floor with cast in-situ structural topping

B.2.2 With non-resisting blocks

The nominal thickness of the cast in-situ concrete topping above the beams, e_1 , and above the blocks, e_2 , should be such that:

- $e_1 \geq 30$ mm and $e_2 \geq 40$ mm if the beam centre distance is ≤ 700 mm;
- $e_1 \geq 30$ mm and $e_2 \geq 50$ mm if the beam centre distance is > 700 mm.

If the imposed load applied is not more than $2,5 \text{ kN/m}^2$ and the beam centre distance is less than 700 mm, the reinforcement of the topping should consist of welded mesh with a cross-sectional area perpendicular to the span of the beams of $0,5 \text{ cm}^2/\text{m}$.

If one of the above conditions is not met, the cross-sectional area of the welded mesh to be laid in the cast in-situ topping should be determined in relation to punching-bending and transverse bending.

If the imposed load is not more than $2,5 \text{ kN/m}^2$ and the floor clear span is not more than 6,00 m, the reinforcing mesh, when not provided for negative moment, may be replaced by reinforcing fibres, such as polypropylene, in the cast in-situ topping.

B.2.3 With semi-resisting blocks

The nominal thickness of the cast in-situ concrete topping above the beams, e_1 , and above the blocks, e_2 , should be such that:

- beam centre distance $\leq 700 \text{ mm}$:
 - $e_1 \geq 30 \text{ mm}$
 - $e_2 \geq 40 \text{ mm}$ if the declared punching-bending resistance of the blocks is greater or equal to 2,0 kN
 - $e_2 \geq 30 \text{ mm}$ if the declared punching-bending resistance of the blocks is greater or equal to 2,5 kN
- beam centre distance $> 700 \text{ mm}$:
 - $e_1 \geq 30 \text{ mm}$
 - $e_2 \geq 50 \text{ mm}$ if the declared punching-bending resistance of the blocks is greater or equal to 2,0 kN
 - $e_2 \geq 40 \text{ mm}$ if the declared punching-bending resistance of the blocks is greater or equal to 2,5 kN

If the imposed load is not more than $2,5 \text{ kN/m}^2$ and the floor clear span is not more than 6,00 m, the reinforcing mesh, when not provided for negative moment, may be replaced by reinforcing fibres, such as polypropylene, in the cast in-situ topping.

If the beam centre distance is greater than 700 mm, or if the imposed load is greater than $2,5 \text{ kN/m}^2$, the cast in-situ topping should be transversally reinforced by either welded mesh within the topping or reinforcing bars laid in transverse ribs left for this purpose perpendicular to the beams.

B.3 Floor systems with composite topping

In the case of floor systems with composite topping, the topping consists partly of the concrete cast between the beams and the blocks and partly of the top of the blocks (see Figure B.2).

The nominal thickness of the cast in-situ concrete topping above the beams, e_1 , should be greater than 30 mm.

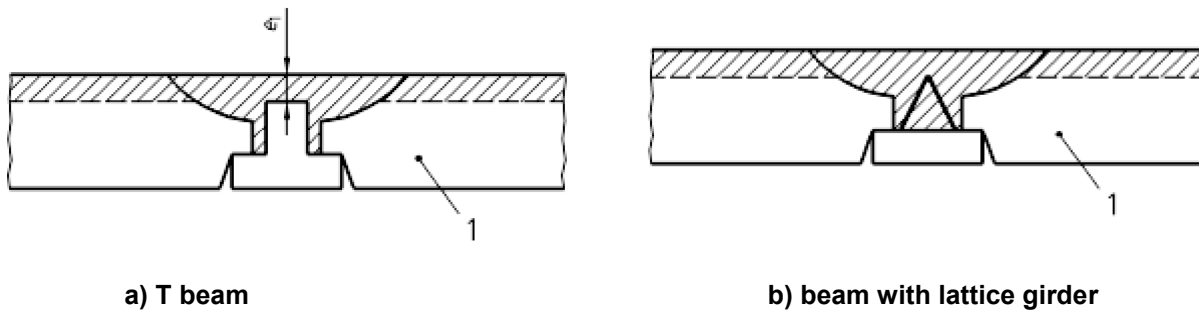

Key

1 Grouted resisting blocks

Figure B.2 — Floor with composite topping

The declared punching-bending resistance of the blocks should be greater or equal to 2,5 kN with also the longitudinal compression criterion given in prEN 15037-2 for concrete blocks and in prEN 15037-3 for clay blocks. The joints between the blocks are grouted.

Composite topping may be made by blocks with dissymmetric upper toes, turning the blocks according to an angle of 180°.

In particular cases (diaphragm action and transverse load distribution not required), no transverse ribs are required if the imposed load is not more than 2,5 kN/m² and if the floor clear span is less than 6,00 m.

If transverse ribs are necessary, they should be at centres no greater than 2,50 m.

B.4 Floor systems with partial topping

In the case of floor systems with partial topping, the topping consists of the concrete cast between the beams and the blocks. The blocks used should be class SR, i.e. either semi-resisting or ungrouted resisting blocks (see Figure B.3).

The nominal thickness of the cast in-situ concrete topping above the beams, e_1 , should be greater than 30 mm.

The use of semi-resisting blocks is restricted to floors on crawl space.

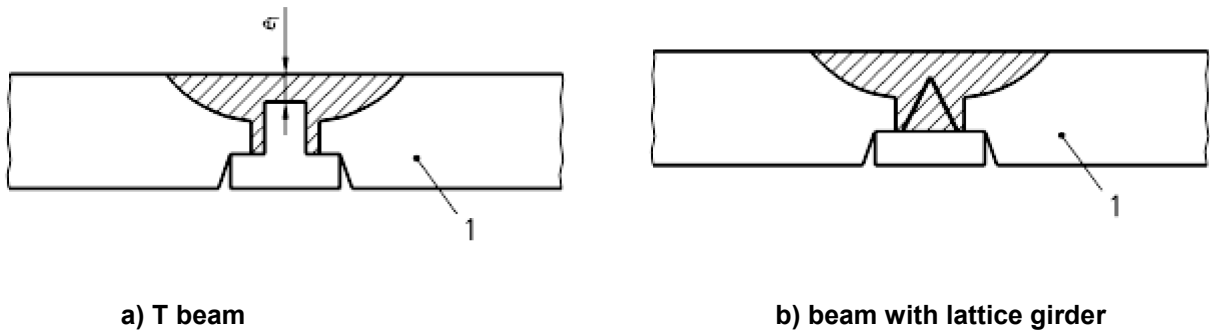

Key

- 1 Semi-resisting or ungrouted resisting blocks

Figure B.3 — Floors with partial topping

In particular cases (diaphragm action and transverse load distribution not required), no transverse ribs are required if the imposed load is less than $2,5 \text{ kN/m}^2$ and if the floor span is less than $5,00 \text{ m}$.

If transverse ribs are necessary, they should be at centres no greater than $2,50 \text{ m}$.

B.5 Floors with self-bearing beams

In floors with self-bearing beams, the beams alone provide the strength of the finished floor system. The blocks used should be class SR: i.e. semi-resisting or ungrouted resisting blocks. These floors are completed by a finished surface such as a screed or wooden floor laid directly on the floor, or a floating screed.

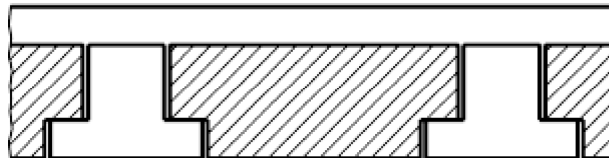

Figure B.4 — Floors with self-bearing beams

Annex C (informative)

Monolithism of composite floor systems

C.1 General

The design shear stress at the interface should satisfy 6.2.5 of EN 1992-1-1:2004 with the values given in Table 3, for all loads applied to the floor.

The calculated shear strength of the composite floor system cannot be greater than the shear strength of the monolithic slab with the same characteristics, and not greater than $0,03 f_{ck}$.

NOTE A calculation per phases may be carried out.

No connecting reinforcement is required if the blocks used comply with Figure C.1, if the beam surface is as defined in 4.3.2.2 and if the beam is dealt with by a quality assessment as defined in Clause 6.

When connecting reinforcements are necessary, they are arranged on the end thirds of the beams.

Nominal dimensions in millimetres

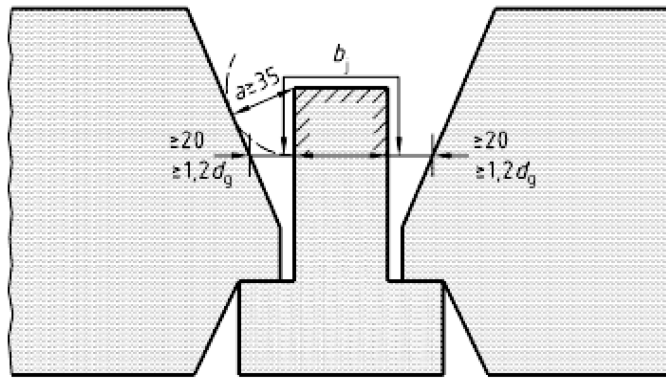

a) case of isolated beams

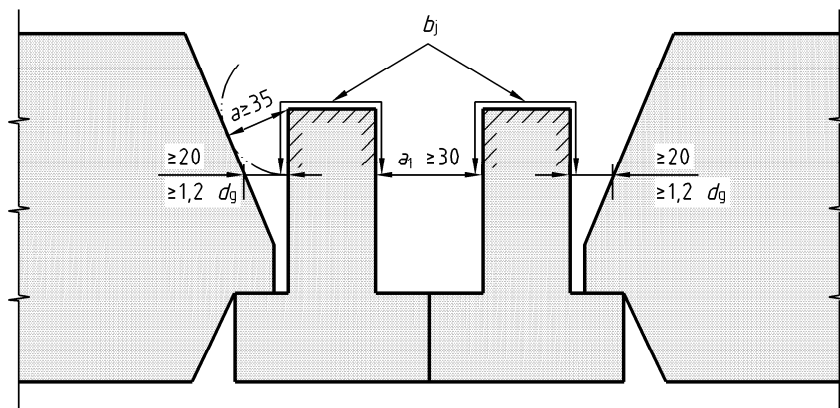

b) case of twin beams

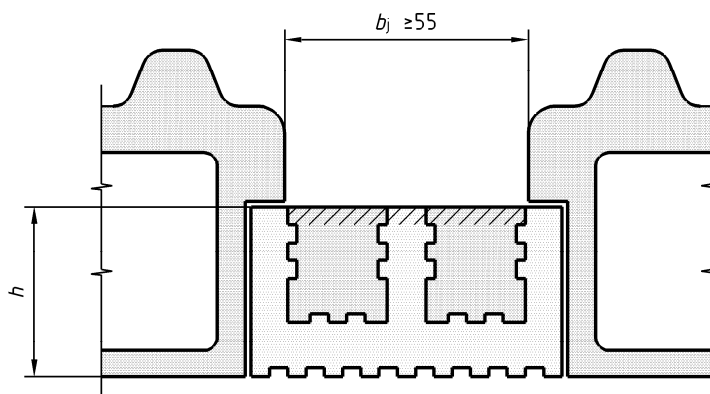

c) case of beams without lattice girder and without web

Figure C.1 — Definition of the effective contour of the interface (the effective contour, b_j , is hatched)

C.2 Strength of connecting reinforcement

The design strength of the connecting reinforcement for two diagonal legs at angles α and α' to the interface (see Figure C.2) is equal to:

$$F_{Rwd,1} = A_{sw} f_{ywd} (\mu \sin \alpha + \mu \sin \alpha' + \cos \alpha)$$

where:

A_{sw} is the cross sectional area of the leg considered, in mm^2

f_{ywd} is the design strength of the steel of which the leg is made, in MPa

μ is the friction coefficient given in Table 3

α and α' are the angles of the legs considered in radians, with $\pi/4 \leq \alpha \leq \pi/2$ and $\cos \alpha \geq 0$
 $\pi/2 \leq \alpha' \leq 3\pi/4$

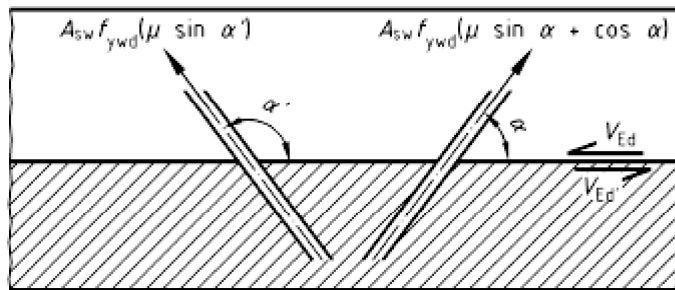
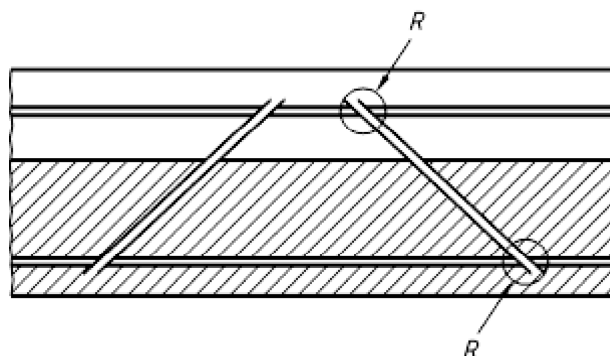

Figure C.2 — Definition of $F_{Rwd,1}$

C.3 Anchorage of connecting reinforcement

The anchorage of connecting reinforcement in the concrete of the beam and in the topping should be designed at ultimate limit state by calculation according to 8.4 and 8.5 of EN 1992-1-1:2004 or by tests. This anchorage is provided by:

- Welded junction or by mechanical junction in the case of discontinuous diagonals (see Figure C.3):
 - in the case of a welded or mechanical junction, the anchorage is considered to be satisfactory, if the rules for shear reinforcement (see 8.5 of EN 1992-1-1:2004) are complied with and if the strength of the welding complies with 7.2.4.2 of EN 10080:2005.
 - for lattice girders, a reduction of 50 % should be applied to the values given in EN 1992-1-1:2004.



Key

R Strength of welded junction (guaranteed by the manufacturer)

Figure C.3 — Welded junction

— Loop in the case of connecting reinforcement with loops without welded longitudinal bar. The anchorage capacity may be determined by test or in accordance with 8.4 of EN 1992-1-1:2004. The values given in Table C.1 for a C20/25 concrete class may be used as simplification:

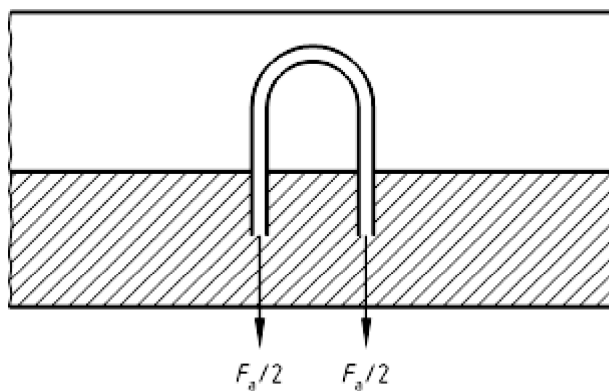

Figure C.4 — Definition of $F_{Rwd,2}$

Table C.1 — Anchorage capacity of loops

Diameter of the loop reinforcement (mm)	4	5	5	6	6	6	7	8
Minimum protruding length of the loops over the beam (mm)	50	50	60	60	70	80	80	80
Minimum loop length anchored into the beam (mm)	80	80	80	80	100	120	120	120
Spacing (distance between the tops of the loops (mm))	80	80	80	80	90	100	120	120
Section of the loop reinforcement for 1 meter length (mm ²)	310	490	490	710	630	570	640	840
Ultimate limit force per loop (kN)								
— $f_{yk} = 235$ MPa	5,1	8,0	8,0	11,6	11,6	11,6	15,7	20,4
— $f_{yk} = 400$ or 500 MPa	8,0	8,0	11,6	11,6	15,7	19,7	20,4	20,4
Ultimate shear resistance by beam (kN) with regards to the lever arm z (mm)								
— $f_{yk} = 235$ MPa	0,064z	0,10z	0,10z	0,15z	0,13z	0,12z	0,13z	0,17z
— $f_{yk} = 400$ or 500 MPa	0,10z	0,10z	0,15z	0,15z	0,18z	0,20z	0,17z	0,17z

When the thickness of cast in-situ concrete over the beam is not sufficient for the minimal protruding length of the loop, loop reinforcements should be used with a welded continuous bar at the top of loops (with the same steel grade and diameter). In this case, the minimum protruding length of the loops over the beam should be reduced by applying a factor equal to 0,6, ultimate limit force values being the same.

If lower loops in the beam are at the level of the lowest longitudinal bars, the anchorage lengths given in Table C.1 are not required.

Loops with spacing lesser than the values given in Table C.1 should be used, with the following conditions:

- spacing is not less than 80 mm
- to take for this loop the ultimate limit force given in Table C.1 for the loop with the same diameter, the same protruding length and the spacing of which is less than or equal to the spacing of the considered loop

If the strength class of the cast in-situ concrete is greater than C20/25 (e.g. $f_{ck} > 20$ MPa), it may be possible to:

- increase the ultimate limit forces per loop by the ratio $1,5/f_{ctk,0,05}$ without exceeding the force corresponding to the design yield strength of reinforcement ($f_{ctk,0,05}$ is the characteristic axial tensile strength of the cast in-situ concrete)
- decrease the anchorage length of the loop by the ratio $\sqrt{f_{ctk,0,05}}/1,5$

Ultimate shear resistance is equal to the ultimate limit force per loop multiplied by the ratio of the lever arm z and divided by the spacing between the top of the loops.

Annex D (informative)

Detailing of supports and anchorage of reinforcement

D.1 General

The erection and connection details should be given in project specifications.

NOTE The main reinforcement may be connected to load bearing members either within the beam or by the protruding part of the main reinforcement at the ends of the beam.

D.2 Construction of supports

D.2.1 Direct support

Beams should be supported on load-bearing members.

If the beams have protruding reinforcement at the ends (with a length a), the actual minimum support length of beams during the temporary phase, b , should be as follows (see Figure D.1 a):

- reinforced concrete or steel support: class A: $b \geq 20$ mm
class B: $b \geq 40$ mm
- masonry support: $b \geq 50$ mm

Except in the case of special calculations or tests, the anchorage length on the support ($a + b$) should be at least 100 mm.

If the beams have no protruding reinforcement at the ends, the actual minimum support length of the beams is that resulting from verification of the anchorage in permanent and accidental situations with a minimum of 60 mm (see Figure D.1 b).

In the case of beams with lattice girder, the edge connection between diagonals and lower chord should be within support or at a distance from the internal edge of the bearing no more than 10 cm or upon the edge prop (see Figure D.1 c).

Dimensions in millimetres

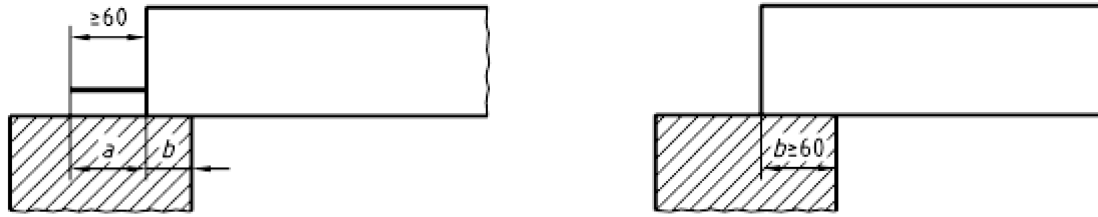

a) beams with protruding reinforcement

b) beams without protruding reinforcement

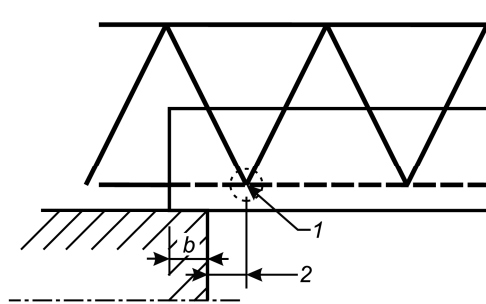

c) beam with lattice girder

Key

- 1 Lower node
- 2 ≤ 10 cm or node within the support

Figure D.1 — Direct support arrangements

D.2.2 Indirect support

If, at the time of erection, the support lengths specified in D.2.1 are not complied with, a linear edge prop should be placed at not more than 650 mm from the internal edge of the bearing (see Figure D.2).

If the anchorage length is not sufficient, one of the following arrangements should be adopted to anchor the beam to its bearings (see Figures D.3, D.4 and D.5).

Nominal dimensions in millimetres

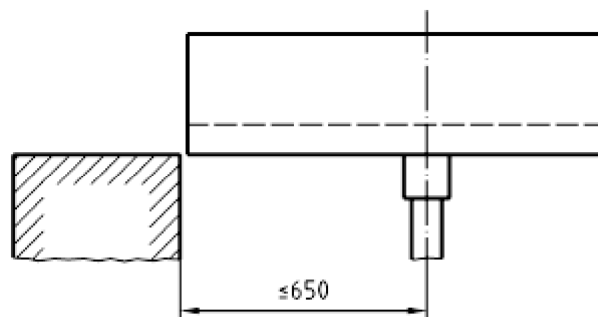
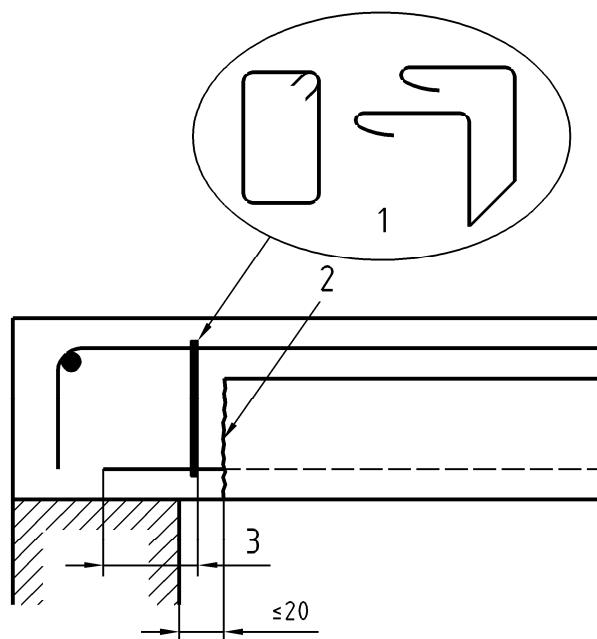

Figure D.2 — Linear edge prop

NOTE The beam may have protruding reinforcement.

Nominal dimensions in millimetres



Key

- 1 Hangers
- 2 Rough end
- 3 $a \geq$ anchorage length

Figure D.3 — Indirect support - case with protruding reinforcement (principle)

NOTE A tie reinforcement is required and it is essential that the support balance the moment resulting from the offset of the load.

Nominal dimensions in millimetres

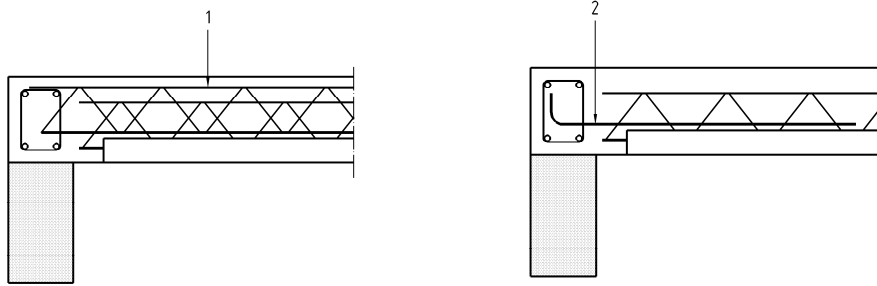

D.4 a): case with lattice girder

D.4 b): case with reinforcement

Key

- 1 Supplementary lattice girder on the beam
- 2 Supplementary reinforcement on the beam

Figure D.4 — Indirect support: case with lattice girder or reinforcement (principle)

Nominal dimensions in millimetres

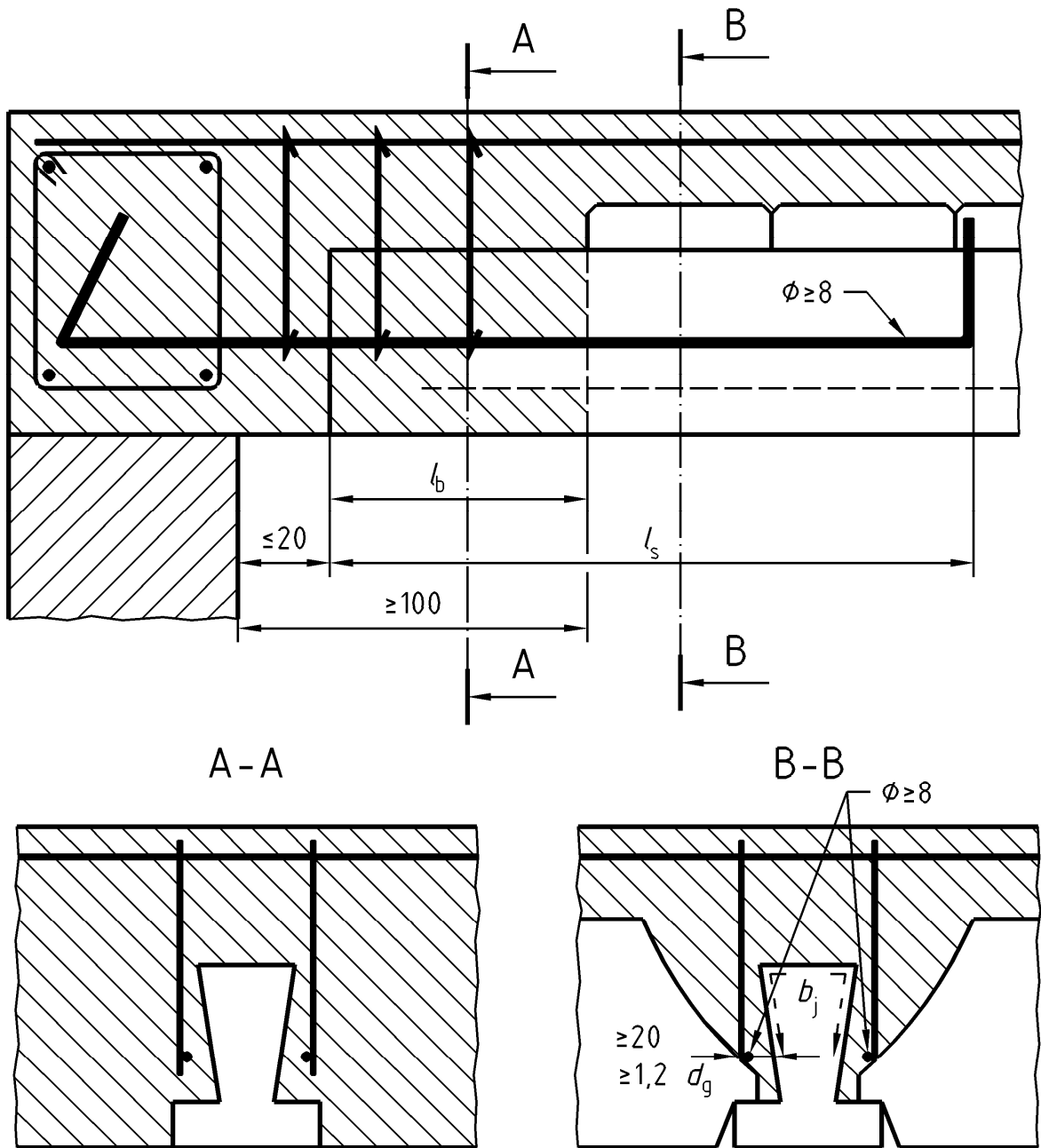

Key

l_s Design lap length according to 8.7.3 of EN 1992-1-1:2004

Figure D.5 — Indirect support – case without protruding reinforcement (principle)

The construction arrangement shown in Figure D.5 should be considered only if all the following conditions are met:

- type of surface conditions of the beams, as defined in Table 3, should be at least type c_{3a} or c_{3b}
- reinforcements anchored in order to take a tensile force, V_{Ed} , should be located near the beam
- shape of the blocks makes it possible to dispense with connecting reinforcement
- length of beam penetration, l_b , into the cast in-situ concrete is such that:

$$l_b \geq \frac{V_{Ed}}{v_{Rdi} b_j}$$

where:

V_{Ed} is the design shear force

v_{Rdi} is the design shear strength as specified in Table 3

b_j is the interface contour defined in C.1

NOTE For rectangular prestressed beams without lattice girders, indirect support is only possible with protruding reinforcement.

D.2.3 Other construction arrangements

Figures D.6 to D.8 give examples of construction arrangements that may be adopted in the case of beams supported from an embedded main beam or a main beam above the floor.

Nominal dimensions in millimetres

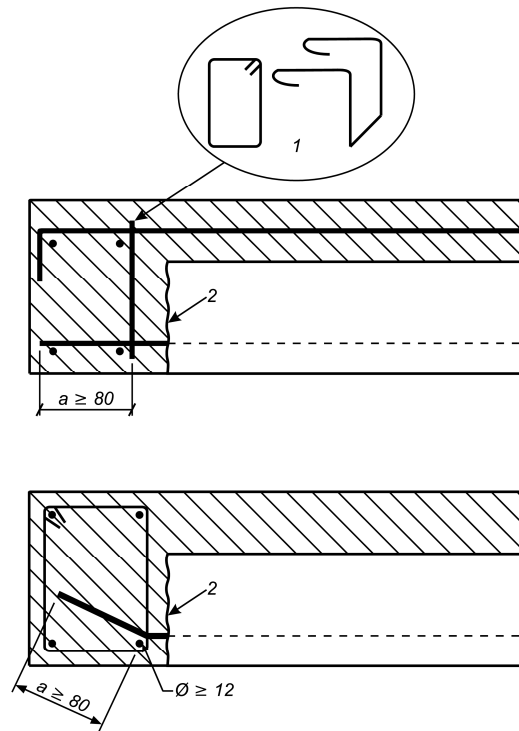

a) from end beam

Key

- 1 Link used as hanger
- 2 Rough end

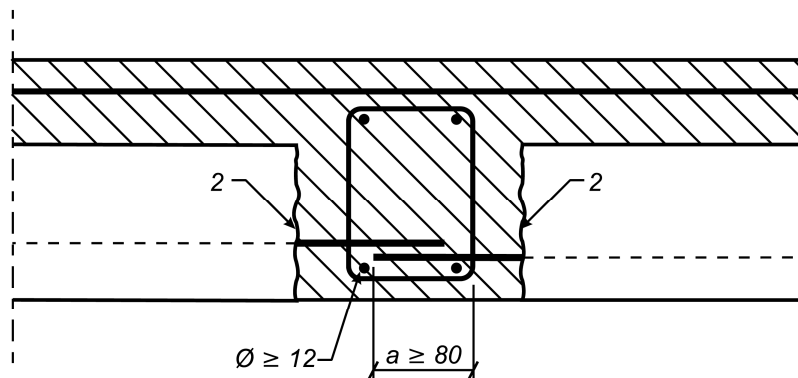

b) from intermediary beam

Key

- 2 Rough end

Figure D.6 — Support from embedded beams – beams with protruding reinforcement (principle)

NOTE If the spacing between stirrups is greater than 15 cm, additional hangers should be added within the embedded beam.

Nominal dimensions in millimetres

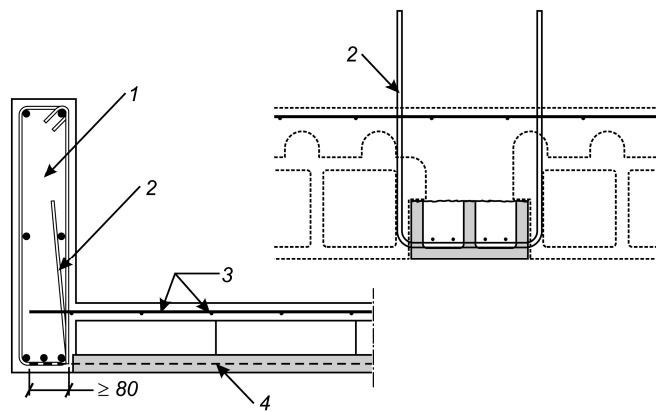

a) normal loads

Key

- 1 Main beam
- 2 Hangers
- 3 Welded mesh fabric
- 4 Beam with protruding tendons

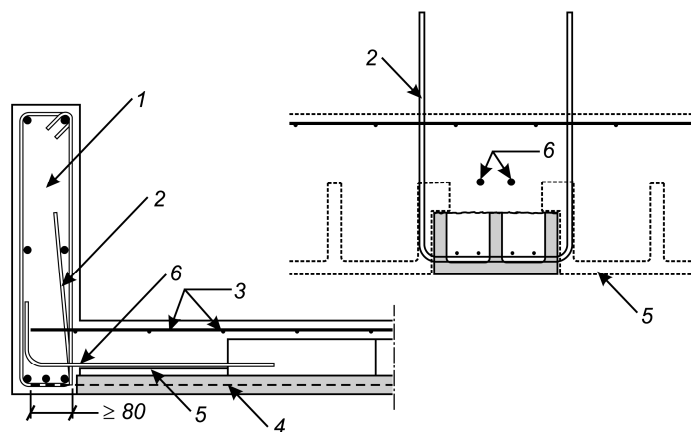

b) heavy loads

Key

- 1 Main beam
- 2 Hangers
- 3 Welded mesh fabric
- 4 Beam with protruding tendons
- 5 Open blocks
- 6 Additional bars

Figure D.7 — Support from main beams above the floor – beams with protruding reinforcement (principle)

Nominal dimensions in millimetres

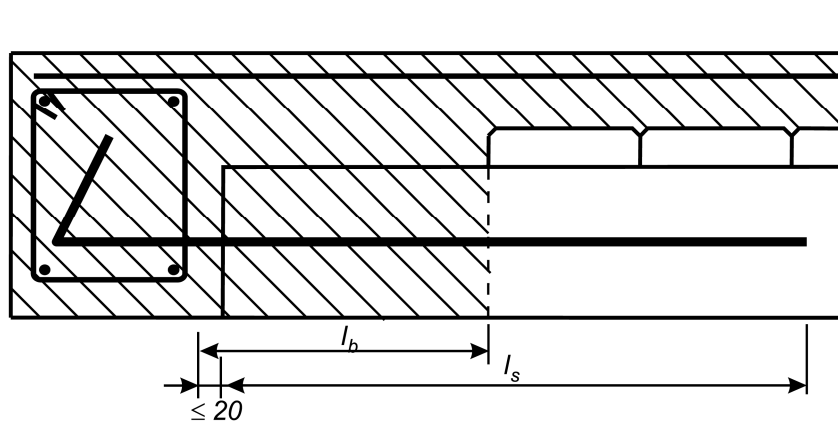

a) from end beam

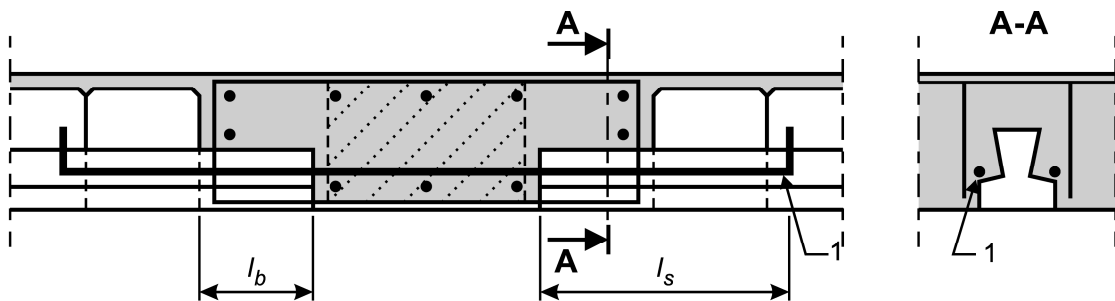

b) from intermediary beam

Key

- 1 Additional reinforcement

Figure D.8 — Support from embedded beams – beams without protruding reinforcement (principle)

The construction arrangement shown in Figure D.7 should be considered only if the conditions of Figure D.5 are met.

D.3 Anchorage of reinforcements

D.3.1 Anchorage on the end support

8.4 of EN 1992-1-1:2004 applies.

If justified by testing the following applies. In the case of beams with protruding reinforcement on direct support (see Figure D.1), the verification is made by considering a reinforced-concrete anchorage over distance a , taking the following value for the design bond strength with the effect of transverse pressure:

$$f_{bd} = k f_{ctk} 0,05$$

where:

k is a coefficient depending on the type of reinforcement:

$k = 1,30$ for plain or indented reinforcement and for indented or undulated prestressing steel

$k = 2,6$ for ribbed reinforcement and for twisted prestressing wires or prestressing strands

For indirect supports, the design bond strength should be evaluated according to 8.4 of EN 1992-1-1:2004.

D.3.2 Negative moments and reinforcement at support

End sections in beam systems made continuous at supports are designed in accordance with EN 1992-1-1:2004, considering the resisting section defined in E.2.6.

In order to limit cracking in the upper fibre of beams due to the possible creation of unintended moments at the supports, the top reinforcement used should be capable of taking an arbitrary moment of $0,15 M_o$, where M_o is the maximum due to the load applied on the corresponding span taken as isostatic. This arrangement is not obligatory when the imposed load is less than $2,5 \text{ kN/m}^2$ and when the span considered is less than $4,50 \text{ m}$.

NOTE It may be remembered that top reinforcement at supports improves the conditions of anchorage at the supports.

Annex E (informative)

Design of composite floor systems

E.1 General

EN 1992-1-1:2004 should be used to design beam-and-block floor systems, taking account of:

- resisting sections given in E.2;
- material properties of the beam specified by the manufacturer;
- partial safety factor specified by the manufacturer for the concrete beam (see Annex C of EN 13369:2004);
- partial safety factors of EN 1992-1-1:2004 for design of the finished floor system;
- class of cast in-situ concrete, which should be at least C20/25;
- continuity over the support where applicable;
- minimum effective span is taken as $(L + 5 \text{ cm})$ where L is the clear distance between the faces of the supports.

The beam concrete strength and characteristics to be taken into account in permanent and accidental phases are those guaranteed by the manufacturer at 28 days.

NOTE In the event that part of the load might give rise to impacts or fatigue phenomena, special substantiation taking account of such effects should be given. If more stringent analysis is not required, these effects may be taken into account implicitly by multiplying the corresponding static actions and/or corresponding strength values by appropriate coefficients (see 4.1.5 of EN 1990:2002).

E.2 Resisting section of the finished floor system

E.2.1 General

Provided monolithism is verified as stated in C.2, the resisting sections of the finished floor system to be taken into consideration in the bending design of the composite floor systems are as stated hereafter.

E.2.2 Floor systems with cast in-situ structural topping

The effective width, b_{eff} , to be considered in design calculations is the distance between the centre line of the blocks either side of the beam or multiples beams (see Figure E.1).

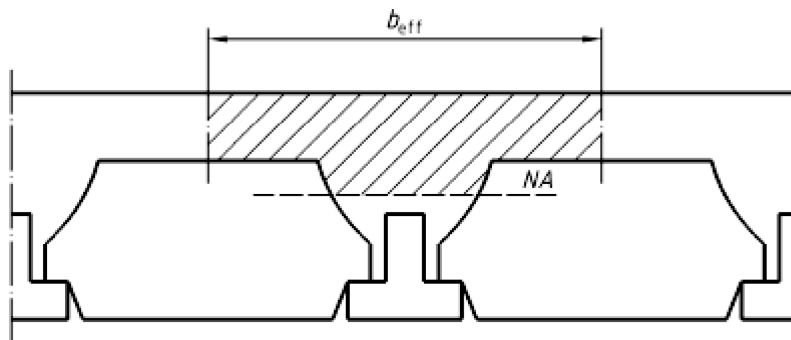

Key

- NA Neutral axis
-  Compression flange

Figure E.1 — Definition of the effective width for floor systems with cast in-situ structural topping

E.2.3 Floor systems with composite topping

a) Concrete or clay resisting blocks not subjected to a longitudinal compression test

If the concrete or clay resisting blocks are not subject to a longitudinal compression test, and if they are used under the conditions defined in B.3, the effective width, b_{eff} , of the compression flange of the floor system to be considered for serviceability limit state and ultimate limit state bending should be as follows, for routine cases (see Figure E.2):

$$b_{eff} = b_0 + \frac{1}{3} b_1$$

where:

- b_0 is the top width of the cast in-situ concrete "stiffening rib" between blocks
- b_1 is the width of the top of the blocks
- e is the depth of the compression flange of the block

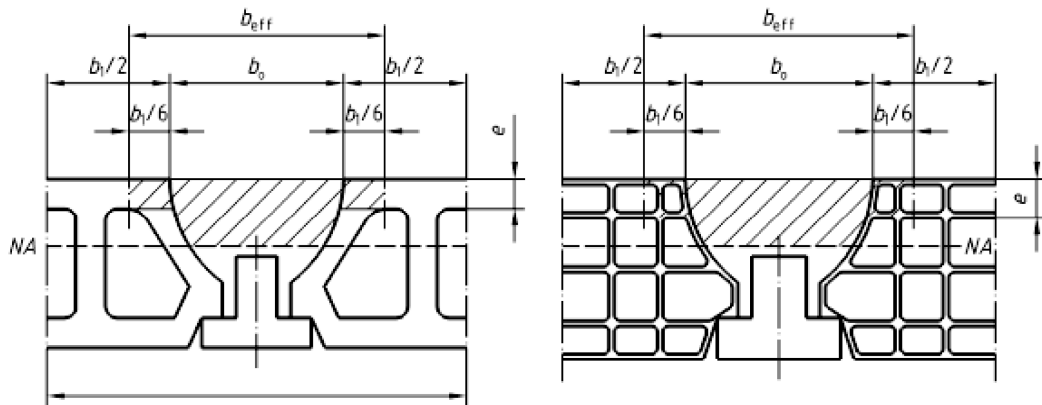

Key

NA Neutral axis



Compression flange

Figure E.2 — Definition of the effective width for floor systems with composite topping (case a)

b) Concrete or clay resisting blocks subjected to a longitudinal compression test

If the concrete or clay resisting blocks are subjected to a longitudinal compression test as defined in 5.2.2 of prEN 15037-2, and if they are used under the conditions defined in B.3, the effective width, b_{eff} , of the compression flange of the floor system to be considered for serviceability limit state and ultimate limit state bending should be the block centre distance (see Figure E.3):

$$b_{eff} = b_0 + b_1$$

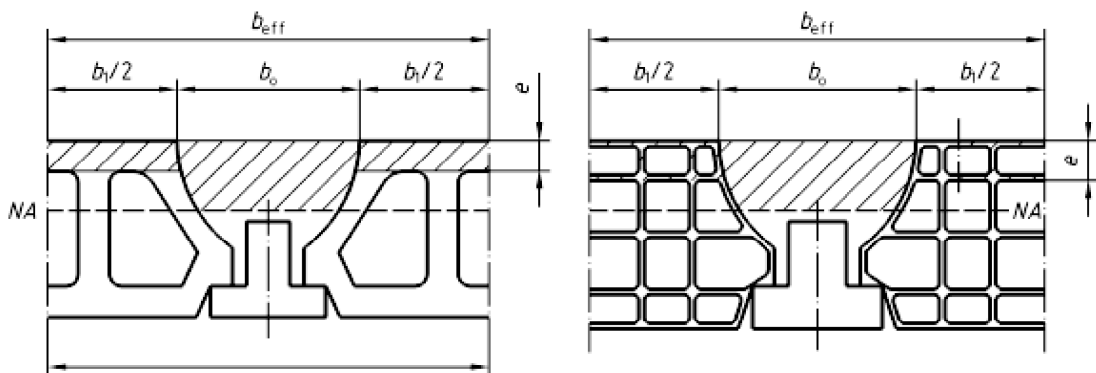

Key

NA Neutral axis



Compression flange

Figure E.3 — Definition of the effective width for floor systems with composite topping (case b)

E.2.4 Floor systems with partial topping

The effective width, b_{eff} , to be taken into account for the serviceability and ultimate limit states is the top width, b_o , of the cast in-situ concrete "stiffening rib" between blocks (see Figure E.4).

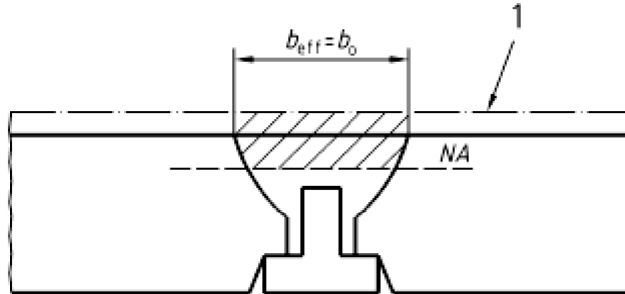

- Key**
- 1 Monolithic screed (optional)
 - NA Neutral axis
 -  Compression flange

Figure E.4 — Definition of the effective width for floor systems with partial topping

NOTE If a monolithic concrete screed is laid at the same time as the stiffening rib is poured, it may be taken into account for the width, b_o , of the cast in-situ concrete stiffening rib between blocks.

E.2.5 Floors with self-bearing beams

The compression flange is that of the beams (see Figure E.5).

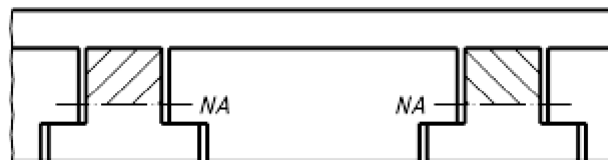

- Key**
- NA Neutral axis
 -  Compression flange

Figure E.5 — Definition of the compression flange for floor with self-bearing beams

E.2.6 Section to be considered under negative moment

The resisting section under negative moment, in current zone of the floor system, should be taken as indicated in the Figure E.6 (hatched area).

Dimensions in millimetres

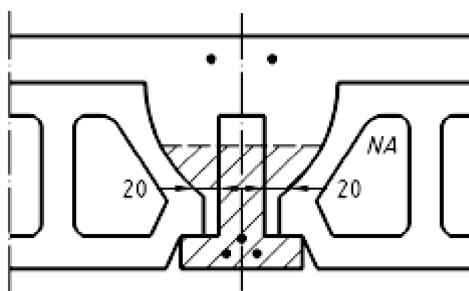

Key

NA Neutral axis



Compression flange

Figure E.6 — Resisting section to be considered

E.3 Design value of the ULS mid-span bending moment (M_{Rd})

The design value of the ULS mid-span bending moment, M_{Rd} (in Nm), is determined as stated in 6.1 of EN 1992-1-1:2004.

If collapse is due to failure of the main reinforcement, the design value of the ULS bending moment, M_{Rd} , can be determined using the following equation:

$$M_{Rd} = \frac{1}{\gamma_R} F_A \times \left(d - \frac{1}{2} \frac{F_A}{b_{eff} f_{cd}} \right) \text{ with } F_A = (n_p F_{pk} + F_{rk})$$

where:

γ_R is the global safety factor for the ultimate moment ($\gamma_R = 1,10$)

d is the distance between the centre of gravity of the force F_A and the further compressive flange, in mm

b_{eff} is the effective width of the compressed part of the resisting section defined in E.2, in mm

f_{cd} is the design compressive strength of the weakest material in the compressed part of the composite section for the ultimate limit state, in MPa

n_p is the number of active prestressing tendons in the beam

F_{pk} is the guaranteed failure force for each prestressing tendon, in N

$F_{rk} = A_s f_{yk}$ for reinforcing steel of total cross-sectional area A_s , in N

$F_{rk} = n'_p A_p f_{p0,1k}$ for prestressing steel with n'_p the number of tendons used as passive reinforcement, in N

E.4 Serviceability limit states

E.4.1 Stress limitation and crack control

The serviceability limit state relating to stress limitation and crack control should be deduced from 7.2 and 7.3 of EN 1992-1-1:2004.

For prestressed concrete beams, the stresses in the upper fibre of the floor system, $\sigma_{c,\text{sup}}$, and the lower fibre of the beams, $\sigma_{c,\text{inf}}$, are determined by considering an uncracked section, with the cross-sectional area of reinforcement possibly being replaced by an equivalent cross-sectional area of concrete, applying the E_s/E_c moduli ratio, by taking the characteristic compressive strength of the weakest material.

E.4.2 Deflection control

E.4.2.1 Principle

The verification of the deformation limit state of beam-and-block floor systems involves limiting the active deflection in order to prevent disorders (cracking, unbonding, etc.) in the works supported by the floor.

Active deflection is due to:

- part of the permanent load applied to the finished floor system before construction of supported works, for which the verification is carried out, as a result of long time creep deformation, considered as a long-term action;
- permanent load applied after construction of the supported works, for which the verification is carried out, considered as a long-term action;
- variable loads applied after construction of the supported works, for which the verification is carried out, considered as a short-term action;
- part of differential shrinkage between the beam concrete and the cast in-situ concrete that takes place after construction of the supported works, considered as a long-term action;
- for prestressed beams, the deferred action of the prestressing force, considered as a long-term action.

E.4.2.2 Deflection limits

The limit value for active deflection depends on the type of works supported by the floor (fragility of partitions and floor finishing, etc.). The active deflection is limited to:

- for masonry partitions and/or brittle floor finishing: $L/500$
- for other partitions and/or non brittle floor finishing: $L/350$
- for roof elements: $L/250$

where L is the span of the floor.

E.4.2.3 Calculation of the active deflection

E.4.2.3.1 Calculation

When a limitation of the floor deflection is necessary with regards to the elements supported, the simplified methods given hereafter may be used for uniformly distributed loads.

The following notations are used in the expressions of active deflection:

- g_1 is the self weight of the beam(s), per linear metre of beam, in kN/m
- g_2 is the self weight of the floor system, less the self weight of the beam(s), per linear metre of beam, in kN/m
- g_a is the permanent load corresponding to supported elements (partitions, floor finishes, etc.) with regards to which active deflection is checked, per linear metre of beam, in kN/m
- g_v is the permanent loads applied on the floor before the load g_a , per linear metre of beam, in kN/m
- g_p is the permanent loads applied to the floor, after the load g_a , per linear metre of beam, in kN/m
- g_q is the permanent part of imposed loads (if it exists) applied to the floor, per linear metre of beam, in kN/m
- q is the variable part of imposed loads applied to the floor, per linear metre of beam, in kN/m
- L is the clear floor span, in mm
- $E_{c,eff}$ is the long-term modulus of elasticity of the concrete, in MPa
- k_a is a coefficient taking account of the increased stiffness due to the blocks; its value should be between 1 (non-resisting blocks) and 1,20 (concrete or clay semi-resisting or resisting blocks)
- α is the ratio between the imposed load and the total load (imposed and permanent load):

$$\alpha = \frac{g_q + q}{g_1 + g_2 + g_v + g_a + g_p + g_q + q}$$

- m is the static moment of the total section S_p of the beam relative to the neutral axis of the finished floor system, in mm³: $m = S_p (V_i - v_i)$, where V_i and v_i are the distances to the lower chord from the neutral axis of the floor section and the neutral axis of the beam section respectively
- ϵ_{cs} is the total shrinkage strain of the cast in-situ concrete according to 3.1.4 of EN 1992-1-1:2004. Except for more accurate calculation, in normal conditions, $\epsilon_{cs} = 3,5 \cdot 10^{-4}$.
- n_s is the tensile stress due to the supposedly prevented shrinkage of the cast in situ concrete ($n_s = 3,0$ MPa)
- d is the effective depth of the cross section, in mm
- $P_{m,0}$ is the final prestressing force, in N
- e_p is the absolute value of the eccentricity of the prestressing force relative to the neutral axis of the resisting section of the finished floor system, in mm
- δ_w, δ_e are the ratios of the moments on the left and right supports, respectively, (in absolute value) to the mid-span moment of the corresponding isostatic span (in absolute value):

$$\delta_w = \frac{M_w}{M_o} \quad \text{and} \quad \delta_e = \frac{M_e}{M_o}$$

a is a coefficient taking into account the reduction of deflection due to continuity:

$$a = 1 - 1,2 \left(\frac{\delta_w + \delta_e}{2} - 0,3 \alpha \right) \text{ for a span in continuity and } 1 \text{ for an independent span}$$

E.4.2.3.2 Floor systems with reinforced concrete beams

The following method may be used to determine active deflection, in mm, due to uniformly distributed loads when the floor is erected with props.

The active deflection f_a is the difference between total deflection w_t and the deflection w_a evaluated immediately after the erection of the elements supported with regards to which the deformation is checked:

$$f_a = w_t - w_a$$

The total deflection w_t is equal to:

$$w_t = \frac{L^2}{8 k_a E_{c,eff}} \left[\frac{(1 - \zeta_t)}{I_{uc}} + \frac{\zeta_t}{I_{fc}} \right] \left[\left(g_1 + g_2 + g_v + g_a + g_p + g_q + \frac{1}{3} q \right) \frac{a L^2}{9,6} \right] + \frac{\epsilon_{cs} L^2}{8 d}$$

where:

- $E_{c,eff}$ is the long-term modulus of elasticity, according to 7.4.3 of EN 1992-1-1:2004

$$E_{c,eff} = \frac{E_{cm}}{1 + \varphi(\infty, t_0)}, \text{ and } \varphi(\infty, t_0) = 2$$

where E_{cm} is the tangent modulus of elasticity of the cast in-situ concrete according to Table 3.1 of EN 1992-1-1:2004

- I_{uc} is the uniform inertia of the uncracked section, in mm^4
- I_{fc} is the uniform inertia of the fully cracked section, in mm^4
- the steel-concrete effective modular ratio is taken as 15
- the precast-cast in-situ concrete effective modular ratio is taken as 1 for the calculation on the basis of uncracked section.

$$\zeta_t = 0 \quad \text{if} \quad M_0 \leq M_{cr}, \text{ and}$$

$$\zeta_t = 1 - \sqrt{\frac{M_{cr}}{M_0}} \quad \text{if} \quad M_0 > M_{cr}$$

$$M_0 = (g_1 + g_2 + g_v + g_a + g_p + g_q + q) \frac{L^2}{8}$$

M_{cr} is the cracking moment corresponding to a concrete tensile stress f_{ctm} in the homogenized section

- The deflection w_a is calculated according to the period t between the unpropping and the erection of the brittle floor finishing:

$$w_a = w_1 + \psi(w_2 - w_1)$$

where ψ is a coefficient of interpolation comprised between 0 and 0,5. Except for more accurate calculation, ψ should be taken as:

$$\psi = 0,50 \frac{t}{90} \quad \text{for } t \leq 90 \text{ days (with } t \text{ in days)}$$

$$\psi = 0,50 \quad \text{for } t > 90 \text{ days.}$$

- If this erection of the brittle works supported occurs just after the unpropping:

$$w_1 = \frac{L^2}{8 k_a E_{cm}} \left[\frac{(1-\zeta)}{I_{uc}} + \frac{\zeta}{I_{fc}} \right] \left[(g_1 + g_2 + g_v + g_a) \frac{a L^2}{9,6} \right] + \frac{2}{5} \frac{\varepsilon_{cs} L^2}{8 d}$$

- If this erection of the brittle works supported occurs a very long time after the unpropping:

$$w_2 = \frac{L^2}{8 k_a E_{c,eff}} \left[\frac{(1-\zeta)}{I_{uc}} + \frac{\zeta}{I_{fc}} \right] \left[\left(g_1 + g_2 + g_v + \frac{1}{3} g_a \right) \frac{a L^2}{9,6} \right] + \frac{\varepsilon_{cs} L^2}{8 d}$$

where:

$$\zeta = 0 \quad \text{if} \quad M_{Gv+Ga} \leq M_{cr}, \text{ and}$$

$$\zeta = 1 - \sqrt{\frac{M_{cr}}{M_{Gv+Ga}}} \quad \text{if} \quad M_{Gv+Ga} > M_{cr}$$

$$M_{Gv+Ga} = (g_1 + g_2 + g_v + g_a) \frac{L^2}{8}$$

For beams with lattice girder beams, this deflection may be reduced by a coefficient (not less than 0,85) which may be demonstrated by testing. Two identical beams (concrete type, dimensions, etc.), with the only difference being the absence of diagonal reinforcement may be tested. The deflection of the beams is compared in order to demonstrate the positive influence of the lattice girder.

E.4.2.3.3 Floor systems with prestressed concrete beams

The deformations are calculated with the mechanical characteristics of the uncracked sections and for a beam or a group of beams.

NOTE 1 Due to the complex phenomena that take place in these floors, erection in several phases and with different components, the following simplified formula gives an estimation of the likely deflection permitting to choose or adapt the installation of floor according to the imposed admissible deflections.

In the case of a uniformly loaded span resting freely on its bearings, the active deflection in mm can be expressed by the following equation:

$$f_a = \frac{L^2}{8 k_a E_{c,eff} I} \left[\left(k_1 g_1 + \frac{1}{2} g_2 + \frac{2}{3} (g_v + g_a) + g_p + g_q + \frac{1}{3} q \right) \frac{a L^2}{9,6} + k_s m n_s - k_p P_{m,0} e_p \right]$$

$E_{c,eff}$ is the long-term modulus of elasticity of the concretes considered for the arrangement after an infinite time, in MPa. In the absence of more accurate calculation taking account of the homogenisation of sections, $E_{c,eff}$ can be taken to be 13 000 MPa

I is the second moment of area of the uncracked section of the floor taken into account for the bending design, in the case of floors with non self-bearing beams, in mm^4

NOTE 2 For floor system with self-bearing beams where the height of blocks is greater than the height of beams, I is the inertia of the beam section and the cast in-situ concrete. I is the inertia of the only beam section in the other cases.

k_1, k_s, k_p are coefficients taking account of the deferred effect of the various actions for which values can be deduced from Table E.1

Table E.1 — Values for coefficients k_1, k_s and k_p

Beam storage time ^a	k_1	k_s	k_p
normal storage > 3 weeks	1/10	1/3	1/10
short storage ≤ 3 weeks	1/5	1/5	1/5
^a The storage time is the time between the end of manufacture and the erection of the beams.			

E.5 Verification of the shear strength in composite systems

E.5.1 General

Composite floor systems with cast in-situ structural topping (see Annex B), floor systems with composite topping, and floor systems with partial topping on which the superstructure is sufficiently rigid to spread point or line load over several beams, need not have shear reinforcement.

For floors in continuity, the increase in shear load may be neglected provided that the difference between the moments about points of support does not exceed 50 % of the isostatic moment of the considered span.

The flange thickness of blocks, e , should be taken into account for the calculation of the resisting width at the verification level considered (see Figure E.7) with the following values:

- semi-resisting or resisting blocks (hollow blocks in concrete or in clay): $e = 1 \text{ cm}$
- solid blocks in concrete: $e = 3 \text{ cm}$
- other cases (e.g. polystyrene blocks, plastic blocks): $e = 0 \text{ cm}$

E.5.2 Floor system with reinforced or prestressed concrete beams

The shear strength of composite beam-and-block floor systems is checked as follows (see Figure E.7):

- below level aa' where the free space between the beam and the blocks is equal to the greater of 20 mm and $1,2 d_g$, the shear strength is determined taking into account the concrete of the beam alone

NOTE 1 The critical level is generally located at level ' aa' '. For beams with overhang, the lower level of the web may be less favourable.

- along the line of lesser strength, corresponding to the top of the beam and the shorter distance from the upper edge of the beam to the blocks, the shear strength is determined taking into account the cast in-situ concrete (see Figure E.7)

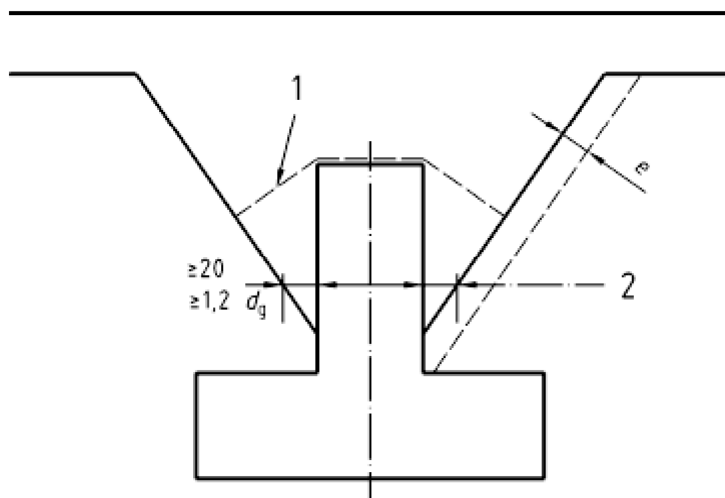

Key

- 1 Line of lesser strength
- 2 Level aa'

Figure E.7 — Definition of verification levels for reinforced and prestressed concrete beams

No shear reinforcement need to be used if the design shear stress, τ_{sd} , at the level considered is such that:

$$\tau_{sd} = \frac{V_{Sd}}{b z} \leq 0,03 f_{ck} \quad \text{where } \tau_{sd} \text{ is the design shear stress in MPa}$$

with

- b is the width of the cross section of the beam at the level considered or the length of the line of the less resistance, in mm
- z is the lever arm at U.L.S, $z = 0,9 d$ for reinforced concrete beams, in mm
 $z = I/S$ for prestressed concrete beams, in mm (S is the static moment calculated at the considered level)
- d is the effective depth, in mm
- f_{ck} is the characteristic compressive strength of the concrete (concrete of the beam or cast in-situ concrete) at the level considered, in MPa

If $\tau_{sd} > 0,03 f_{ck}$, shear reinforcement should be placed over the depth of the resisting section and should be anchored beyond that point. The percentage of shear reinforcement is evaluated according to 6.2.3 of EN 1992-1-1:2004.

When, in prestressed concrete beams, shear reinforcements are necessary, these are arranged over:

- 50 cm or $l_{pt}/2$ (whichever is the greater) when the transverse reinforcements are necessary because the permissible stress of the concrete of the beam has been exceeded, and
- over the length over which the permissible stress of the site-mixed concrete is exceeded

NOTE 2 Only the reinforcement crossing the probable shear crack should be taken into account.

E.5.3 Floor system with lattice girder beams

E.5.3.1 Zones of verification

It is necessary to verify the ultimate shear stresses of concrete at all the levels of the section and the strengths that can equilibrate the diagonals of the lattice girder. This leads to various verifications to each of which corresponds ultimate limit shear strength.

Figure E.8 describes the zones where the various verifications should be done (only for lattice girder with high bond longitudinally reinforcement in the bottom), with:

- $V_{cu}, V_{c'u}$ ultimate limit shear strength limited by the concrete shear stress in the rib;
- V_{wu} ultimate limit shear strength limited by the strength of the welds at the interface;
- V_{du} ultimate limit shear strength limited by the strength of the welds of the diagonal of the lattice girder;
- y_{cu} distance from the under-face of the upper reinforcement ensuring the anchorage of the diagonals of the lattice girder, equal to:
 - 2 cm if the strength of the upper welds is equal to the strength of the diagonals;
 - 3 cm if the strength of the upper welds is equal to 60 % of the strength of the diagonals.

NOTE Linear interpolation may be permitted for intermediate values.

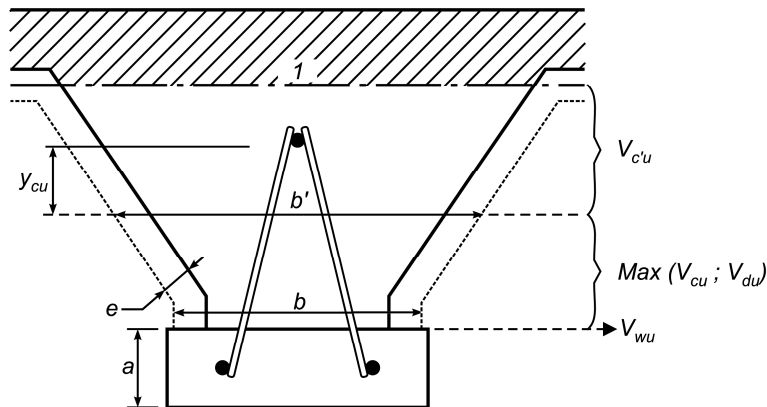

Key

- 1 Neutral axis

Figure E.8 — Definition of verification levels for beams with lattice girder

The shear stress along the thickness of the toe rebate (noted a in Figure E.8) should be verified when the beam includes strengthening reinforcement which is not tied up with the diagonals of the lattice girder. The shear stress is limited to τ_{cu} as defined in E.5.3.2. If the design value is higher than τ_{cu} , connecting horizontal reinforcement should be added.

E.5.3.2 Design of ultimate shear strengths

a) Concrete shear stress of the rib

The verification of V_{cu} is not necessary when the upper chord of the beam is entirely located at least at y_{cu} cm above:

- neutral axis of the section;
- or the lower face level of the upper flange of hollow resisting blocks;
- or the surface level of non-resisting blocks
 - of the section (example in Figure E.9a))
 - of hollow resisting blocks in Figure E.9b)
 - of non resisting blocks in Figure E.9c).

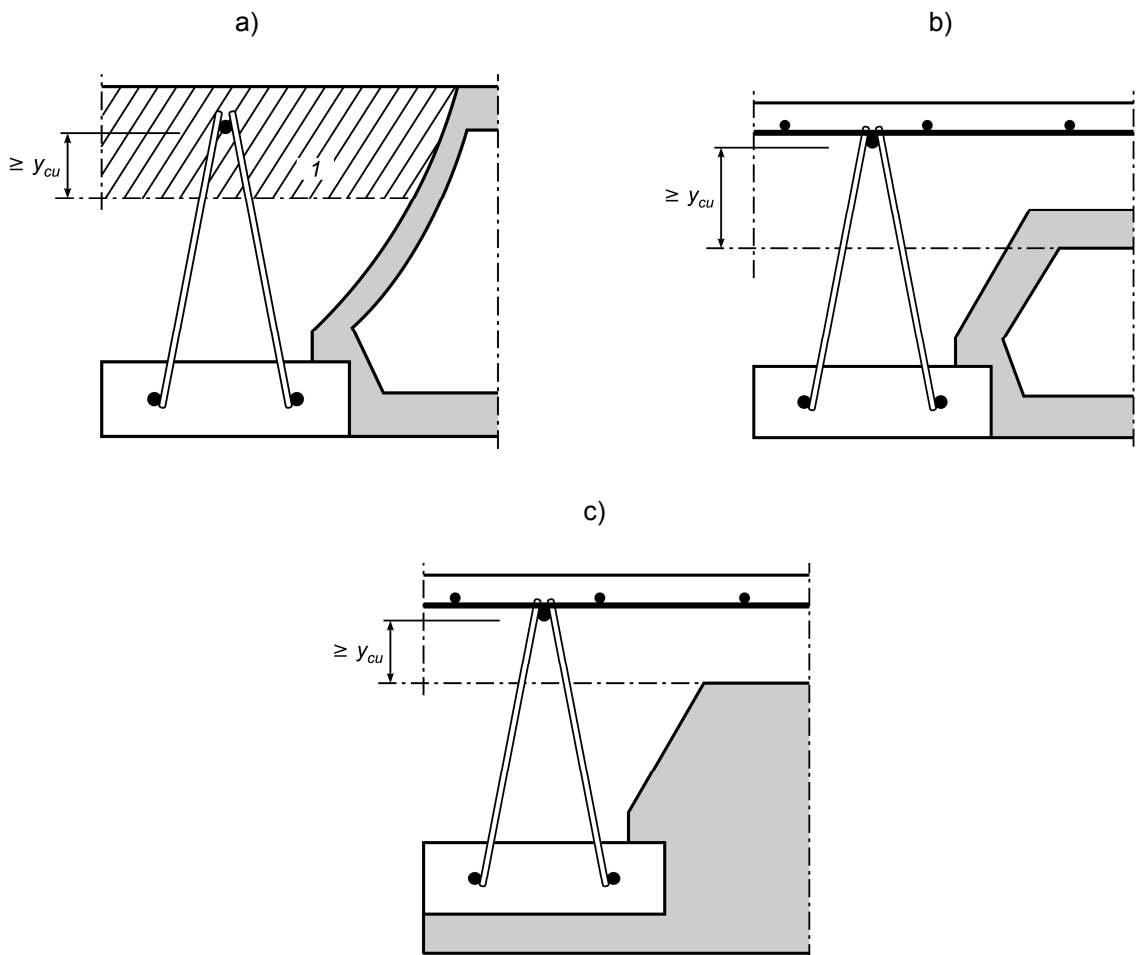

Key

- 1 Neutral axis

Figure E.9 — Cases where the verification is not necessary

$$V_{cu} = \tau_{cu} b z \qquad V_{cu} = \tau_{cu} b' z$$

$$\tau_{cu} = 0,03 f_{ck}$$

where:

- f_{ck} is the characteristic compressive strength of the cast-in-situ concrete
- b is the least horizontal width of the rib increased by the conventional flange thickness of blocks, in mm
- b' is the width of the rib measured 2 cm under the diameter of the upper bar increased by the conventional flange thickness of blocks, in mm
- z is the lever arm at U.L.S, $z = 0,9 d$, in mm
- d is the effective depth of the section, in mm

b) Shear stress at the interface between the two concretes

Beams with prefabricated heel in concrete require a verification of the shear stress at the interface between the two concretes. This monolithism is assured by the diagonals of the lattice girders (if the angle with the interface is greater than 45°) and if necessary by complementary transversal reinforcement.

This verification is not necessary when the reinforcement is embedded directly and in totality in the in-situ concrete (no construction joint).

The two diagonals, one in a favourable direction, the other in an unfavourable direction are taken into account.

The strength of the welds of diagonals with the lower reinforcements should be determined by tests systematically as part of a supervised self-control. In general, the test is a tensile test on a diagonal, in its direction, the lower reinforcement being fixed without possible rotation.

The value, R , is determined from an important number of tests (at least one hundred), with a fractile of 95 % (guaranteed value).

The available strength in a diagonal, F_d , is the smallest value between:

$$A_d \frac{f_{yk}}{\gamma_s} \text{ and } \frac{R}{\gamma_s}$$

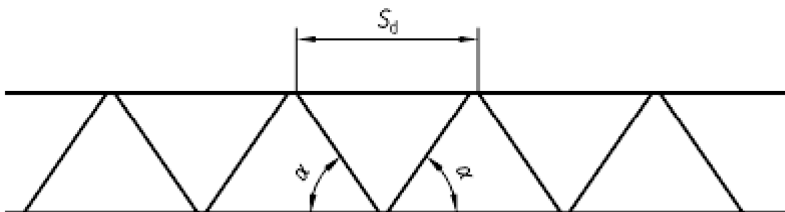

$$V_{wu} = 2 F_d \sin \alpha \frac{z}{s_d}$$

Figure E.10 — "WARREN" type lattice girder

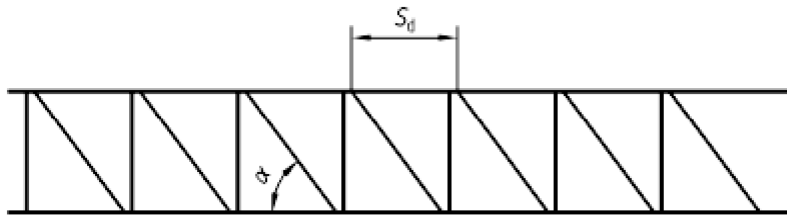

$$V_{wu} = F_d (1 + \sin \alpha + \cos \alpha) \frac{z}{s_d}$$

Figure E.11 — "PRAT" type lattice girder

s_d spacing between two parallel diagonals.

c) Shear stress into the reinforced zone with lattice girder

$$V_{du} = F_d (\cos \alpha + \sin \alpha) \frac{z}{s_d} + 0,35 f_{ctk0,05} b z$$

E.5.3.3 Strengthening by lattice girder

In Figures E.12 and E.13, indexes 1 and 2 are used for V_{wu} and V_{du} where respectively the shear strengths are balanced by the diagonals of the lattice girder or by the strengthening reinforcements.

When the total shear strength, V_{du} , is calculated ($V_{du1} + V_{du2}$), the contribution of the concrete should be taken into account only once.

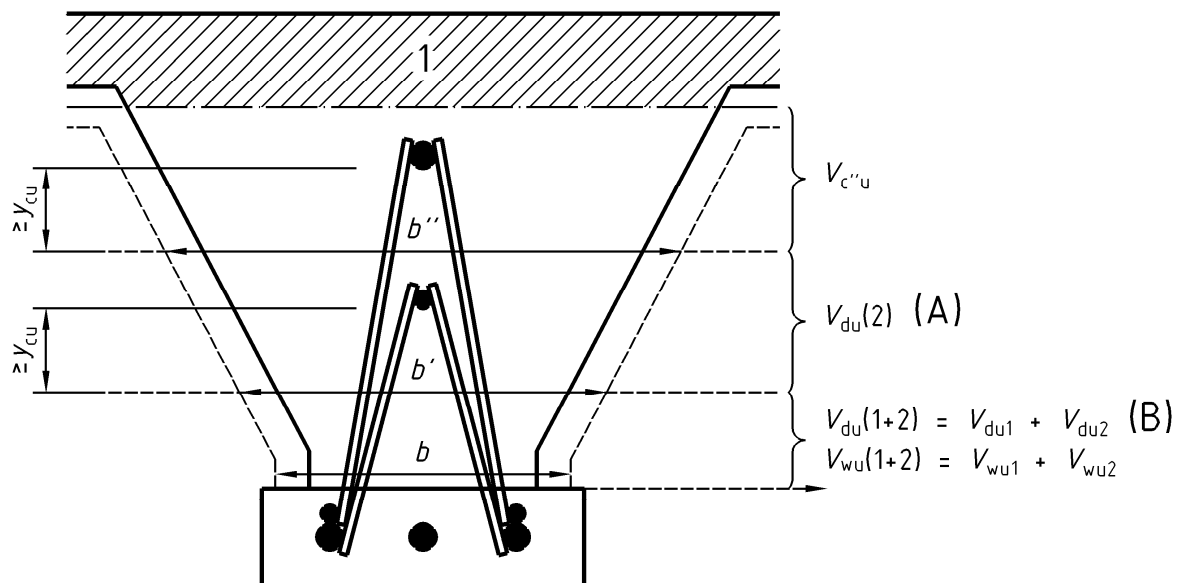

Key

- 1 Neutral axis
- (A) (calculated with b')
- (B) (calculated with b)

Figure E.12 — Case of superposed lattice girders anchored in the concrete

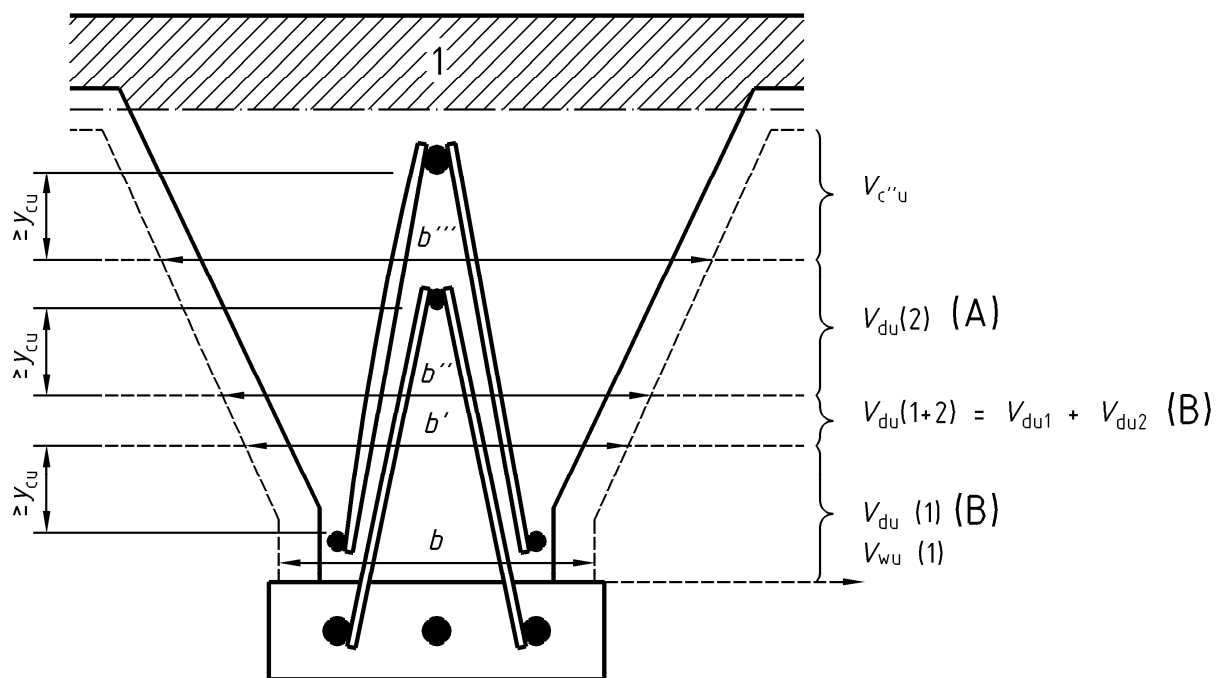

Key

- 1 Neutral axis
- (A) (calculated with b')
- (B) (calculated with b)

Figure E.13 — Case of superposed lattice girders put on the concrete

Annex F (informative)

Design of self-bearing beams

F.1 General

The design of floors with self-bearing beams involves verifying the strength of the beam with respect to the load combinations considered in ultimate limit state and serviceability limit state conditions for permanent and accidental situations. Self-bearing beams should be designed either by calculation in accordance with EN 1992-1-1:2004 and in conjunction with the provisions of this annex, or type tests, according to 4.3.3.3.

F.2 Design value of the ultimate limit state bending moment

The design value of the ultimate limit state bending moment, M_{Rd} , should be determined according to 6.1 of EN 1992-1-1:2004, taking into account the material properties, the partial safety factors and the dimensional tolerances declared by the manufacturer, according to 4.3 of this standard.

F.3 Serviceability limit state of prestressed beams

F.3.1 Stress limitation and crack control

The method given in E.4.1 should apply for prestressed self-bearing beams.

F.3.2 Deflection control

The principle given in E.4.2.1 should apply for prestressed self-bearing beams, to limit the active deflection according to E.4.2.2. The verification of the deformation involves limiting also the total deflection.

The deflection limit considered should be equal to $L/250$ or $L/500$ if deflection should damage adjacent parts of the structure. The total deflection w_t , estimated with effect from the erection of the floor, should be assessed with following equation:

$$w_t = \frac{L^2}{8 E_{c,eff} I} \left[\left(\beta g_1 + g_2 + g_v + g_a + g_p + g_q + \frac{1}{3} q \right) \frac{L^2}{9,6} - \beta P_{m,0} e_p \right]$$

$E_{c,eff}$ is the long-term modulus of elasticity according to 7.4.3 of EN 1992-1-1:2004, $E_{c,eff} = \frac{E_{cm}}{1 + \varphi(\infty, t_0)}$

β is the coefficient taking account of the long time action of the self weight of the beams and of the prestressing force (see 7.4.3 of EN 1992-1-1:2004)

NOTE The other definitions are given in E.4.2.3.

F.4 Design value of the resisting shear force

The shear force of self-bearing beams should be calculated according to 6.2 of EN 1992-1-1:2004.

Annex G (informative)

Diaphragm action

G.1 General

Beam-and-block floor systems with a cast in-situ structural topping can act as diaphragm for the transfer of lateral forces to the bracing vertical structures.

For considering diaphragm action in normal conditions (only wind bracing), the reinforcement sections to be placed are the minimum sections currently used.

In seismic zones, the following rules should be satisfied:

- minimum thickness of the topping should be at least equal to the thickness defined in Annex B;
- topping should be reinforced by a continuous welded mesh, fully anchored on the edge supports. The cross-sectional area of the reinforcement perpendicular to the span of the beams, A_1 , and the cross-sectional area of the reinforcement parallel to the span of the beams, A_2 , should be at least:
 - in low and medium seismic zones according to EN 1998: $A_1 \geq 1,0 \text{ cm}^2/\text{m}$ and $A_2 \geq 0,5 \text{ cm}^2/\text{m}$;
 - in high seismic zones according to EN 1998: $A_1 \geq 1,4 \text{ cm}^2/\text{m}$ and $A_2 \geq 0,7 \text{ cm}^2/\text{m}$.

For the determination of the thickness of the topping, h_0 , and the cross sectional area of reinforcement, A_s , (for 1 m floor width) the following rules should be verified:

$$V_{sd} \leq V_{rd1} + V_{rd3} \quad \text{and} \quad V_{sd} \leq V_{rd2}$$

with

$$V_{rd1} = 0,23 f_{ctk,0,05} h_{ef}$$

$$V_{rd3} = 0,72 A_s f_{yk}$$

$$V_{rd2} = 0,20 f_{ck} h_{ef}$$

where:

V_{sd} is the horizontal shear force developed for 1 m length under the seismic action, in kN/m

f_{ck} is the characteristic compressive cylinder strength of cast in-situ concrete at 28 days, in MPa
(in the absence of specific information, $f_{ck} = 25 \text{ MPa}$)

$f_{ctk,0,05}$ is the characteristic axial tensile strength of the cast in-situ concrete, in MPa

f_{yk} is the characteristic yield strength of reinforcement, in MPa

$h_{ef} = h_0 + 10$ for concrete and clay blocks, otherwise $h_{ef} = h_0$ (non-resisting blocks), in mm

G.2 Case of low rise building

When the diaphragm action is small, like in the case of low-rise building, the cast in-situ topping may be omitted by adopting the following arrangements, only for low and medium seismic zones:

- blocks are resisting blocks made of concrete or clay and are jointed;
- system of horizontal ties is provided with ribs (minimal section of 160 cm^2) laid out perpendicular to the span of the beams with a maximum spacing of 2 m. The cross sectional area of reinforcement of the ribs is at least 2 cm^2 ;
- reinforcements are laid out above and parallel to the beams, at the level of the intermediate supports with a cross section at least equal to $1 \text{ cm}^2/\text{m}$ (for 1 m floor width) and a length on both sides of the support equal to the lap length increased by the height of the beam.

Annex H (normative)

Testing to determine erection spans

H.1 General

The aim of these tests is to determine the erection spans with regard to the following criteria:

- mid-span bending resistance: determination of the failure load and of flexural rigidity (checking of deformation);
- flexural resistance and support: determination of failure load.

These initial type tests shall be carried out on each type of beam (unique cross-sectional area and reinforcement pattern) at the time of first production or when production methods are changed.

This initial type testing is intended to check the reliability of the design model assumed in calculation.

NOTE 1 When the configuration of beams and reinforcement are similar, the interpolation is allowed.

NOTE 2 The checking of the deflection is optional in the case of prestressed beams.

H.2 Determination of erection span

H.2.1 General

The erection span, l_{er} , shall satisfy both failure and deflection criteria in considering the static systems in Figure H.1, which give the maximum values for stress in the spans and at the supports.

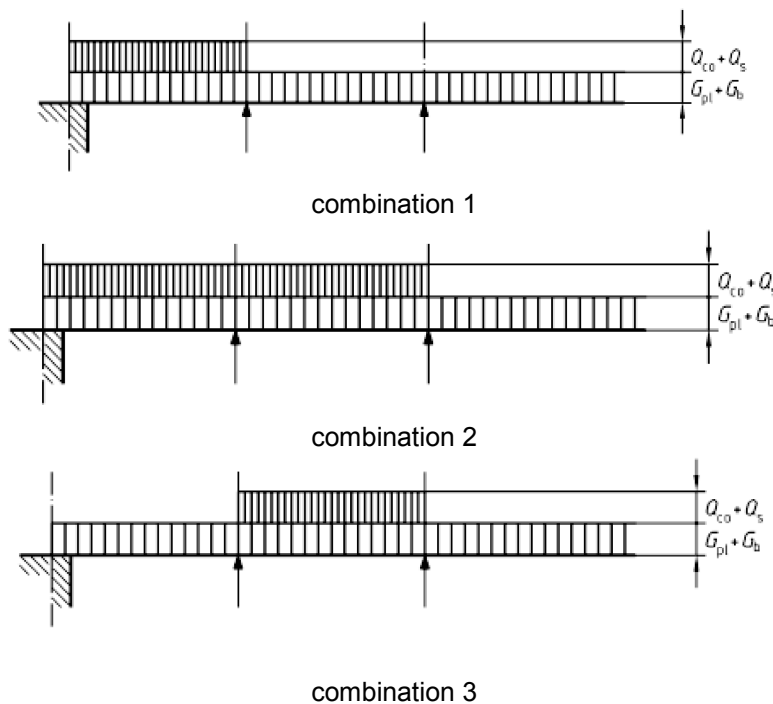

Figure H.1 — Static systems to be considered

H.2.2 Failure design

It shall be checked, by initial calculation, that the load corresponding to the ultimate limit state for bending and shear is at least equal to that due to the combination of actions:

$$\gamma_{Gpl} (G_{pl} + G_b) + \gamma_{Qco} Q_{co} + \gamma_{Qs} Q_s$$

where:

G_{pl} is the beam self weight

G_b is the self weight of blocks associated with beams

Q_{co} is the weight of the cast in-situ concrete

Q_s is the temporary loads during floor construction

NOTE Until such time when European regulations set the value of Q_s , a value of 1,5 kN may be used, and applied in the middle of the erection span.

H.2.3 Checking of the deflection

In the case of reinforced concrete beams, the mid-span deflection between props or between bearing supports shall not be more than $l_{ef}/500$ from the horizontal for the combination of actions ($G_{pl} + G_b + Q_{co}$).

NOTE This check is carried out without taking account of the load Q_s , which is considered to be an accidental load.

H.3 Apparatus

The testing machine shall be at least a class 3 machine according to EN 12390-4:2000.

The loading device shall be articulated. The dial gauges used to measure deflection shall be capable of measuring to within 0,1 mm.

H.4 Test arrangement

H.4.1 General

Tests shall be carried out by the manufacturer, at a testing laboratory or in the factory.

The test shall be performed at a temperature between 0 °C and 40 °C. The temperature shall be recorded.

The test piece shall be the beam alone. The age of the test piece shall be at more 7 days.

The beam shall be supported on rollers (at least one of which shall be free to rotate) with 50 mm ± 5 mm wide and 10 mm ± 3 mm thick repartition pads if the lower face of the beam is irregular.

The load (P) shall be applied, as shown in Figure H.2 for bending tests and in Figure H.3 for shear tests, by means of two 10 mm ± 3 mm thick repartition pads capable of absorbing any surface irregularities.

The test spans shall be relevant to the type of test carried out so that in a bending test the beam fails in bending and in a shear test the beam fails in shear.

H.4.2 Bending tests

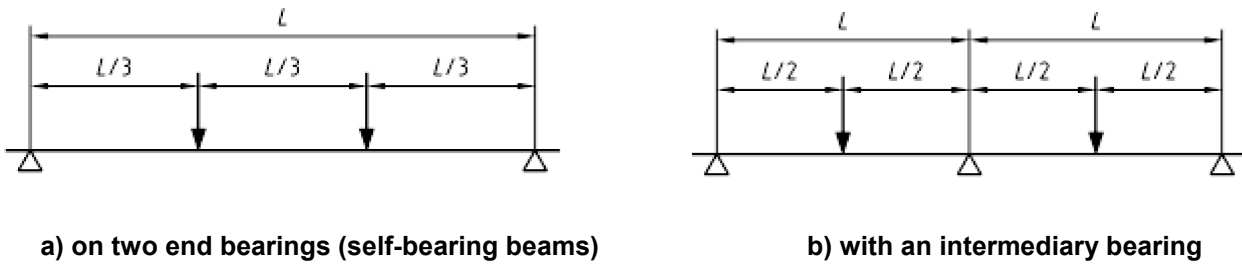

Figure H.2 — Loading arrangement for bending tests

NOTE The spans, *L*, should be similar to those estimated for the erection spans.

H.4.3 Shear tests

Dimensions in millimetres

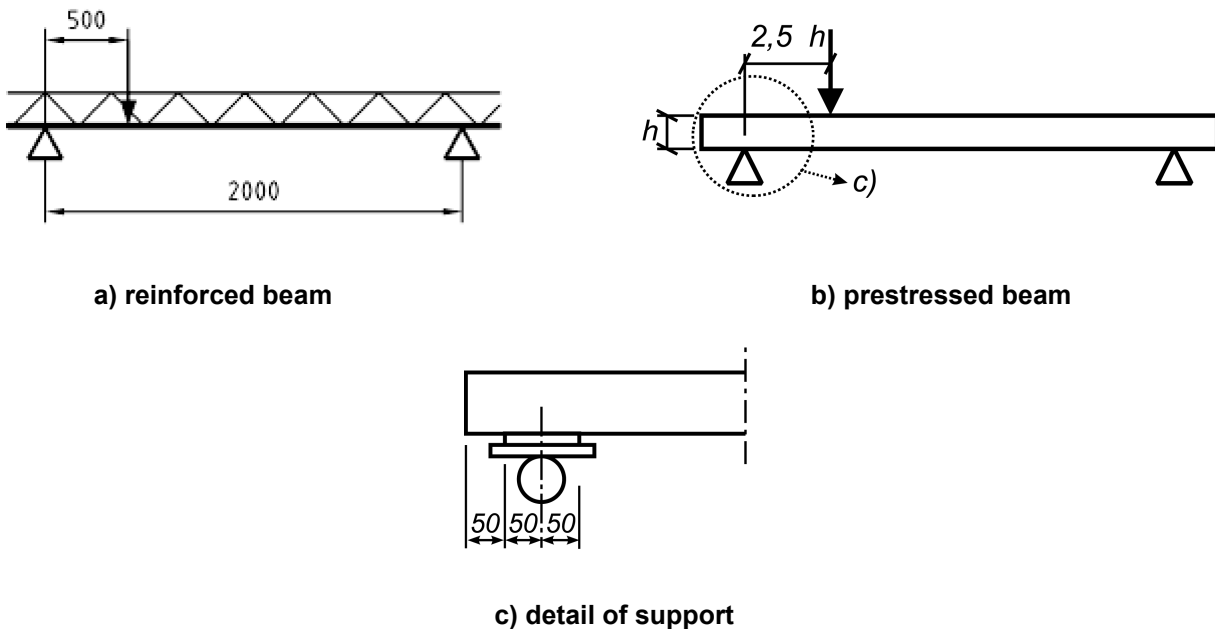

Figure H.3 — Loading arrangement for shear test

H.5 Loading procedure

A load up to 10 % of the maximum expected load shall be applied then withdrawn, to seat the beam (seating load), and loading shall then be applied as follows:

- a) Loading to check the failure load only

Progressively and incrementally, the beam shall be loaded to failure. The failure load, P_R , is the maximum load the beam can withstand.

b) Loading to check the failure load and the deflection

- 1) progressively and incrementally. After each load increment (25 %, 50 %, 75 % and 100 % of P_{flim}), the mid-span deflection of the test piece shall be measured and corrected for bearing settlement which shall be measured at the same time as the mid-span deflection;
- 2) when the mid-span deflection corrected for bearing settlement has reached $L/500$, the load applied at that time shall be recorded (P_{flim}). The corresponding mid-span deflection and bearing settlement shall be recorded;
- 3) in the case of beams with steel lattice girders, the load shall be removed and the residual deformation measured (removal of the load is optional in other cases);
- 4) after 5 min to 10 min without load (where applicable) the beam shall be loaded to failure, using the same rate of loading as previously. The failure load, P_R , is the maximum load the beam can withstand.

During these loading phases, the loading shall be stopped if an event requiring analysis occurs.

H.6 Interpretation of results

H.6.1 Non self-bearing beams

The measured deflection during the test under the combination of actions given in H.2.3 shall not be greater than $l_{er}/500$.

As an indication of bending and shear capacity of the element in its intended use, the following conditions may be considered:

- bending moment capacity calculated under the combination of action given in H.2.2 should not be greater than $M(P_R)/\gamma_E$;
- shear capacity calculated under the combination of actions given in H.2.2 should not be greater than $V(P_R)/\gamma_E$.

where:

l_{er} is the test span

$M(P_R)$ is the failure moment of the critical section obtained in the test

$V(P_R)$ is the failure shear of the critical section obtained in the test

γ_E is the factor taking into account the coefficient of variation of the material strength, of the design model and of the geometry.

NOTE It may be taken $\gamma_E = \gamma_F \gamma_S$ if the failure is due to steel, $\gamma_E = \gamma_F \gamma_C$ if the failure is caused by concrete. The values of γ_F , γ_S and γ_C may be taken from the relevant parts of Eurocodes.

For the calibration of the design model (verification by calculation aided by testing – see 4.3.3.3), initial type tests shall be carried out on three specimens for each test arrangement. The results shall be considered positive if the following conditions are met:

$M(P_R)/M_{calc} \geq 0,95$ for each tested specimen;

$\text{average}\{M(P_R)/M_{calc}\} \geq 1,0$ for the mean ratio of the three tests;

for the bending test, and

$V(P_R)/V_{calc} \geq 0,95$ for each tested specimen;

$\text{average}\{V(P_R)/V_{calc}\} \geq 1,0$ for the mean ratio of the three tests.

for the shear test, where M_{calc} and V_{calc} are the resistant bending moment and the resistant shear force calculated for the critical section of the specimen in the test arrangement, with the actual dimensions and the actual material properties and with $\gamma_S = \gamma_C = 1$.

For monitoring tests only one test shall be performed. The result shall be considered positive if the following condition is met: $V(P_R) > 0,95 V_{calc}$

The failure mode observed in the test shall correspond to the model assumed in calculation.

H.6.2 Self-bearing beams

If the test is a bending test, the load versus mid-span deflection shall be recorded, with the deflection corrected for settlement of the bearings. An example of such a diagram is given in Figure H.4.

The tests shall be interpreted in accordance with Clause 5 and Annexes C and D of EN 1990:2002, taking account of the results of tests performed previously, at the time of first manufacture (or modification to the manufacturing process) of the type of beams studied, and of the results of tests carried out as part of the quality control programme.

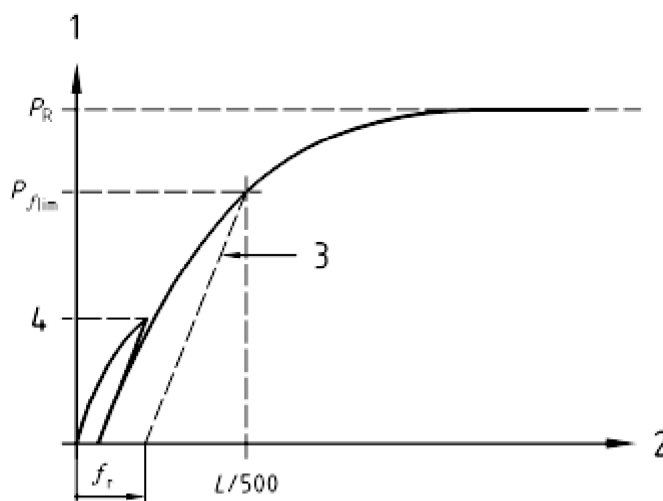

Key

- 1 Load applied
- 2 Mid-span deflection
- 3 For beams with lattice girders
- 4 Seating load
- P_R Failure load
- f_r Residual deflection

Figure H.4 — Load versus mid-span deflection diagram

H.7 Test report

The test report shall mention:

- identification of the test piece;
- span of the beam or the test specimen;
- date of manufacture or some other code;
- date and place of testing;
- laboratory and the person in charge of testing;
- characteristics of materials required for testing;
- test method;
- measuring equipment used;
- seating load and the residual deflection (where applicable);
- value of P_{flim} (where applicable);
- observations regarding the test and any disorders noted (cracks, etc.);
- failure load value, P_R ;
- type of failure;
- load versus deflection diagram for self-bearing beams only (optional);
- declaration that the tests were carried out in compliance with this standard, plus details of any amendments made.

Annex J (informative)

Concrete strength at time of release of tendons

J.1 General

J.1.1 Procedure

The minimum compressive strength that the concrete has to reach before release of tendons should be determined by crushing cube or cylinder specimens. If the tested specimens are different than the standardised cylinder 150 mm × 300 mm, coefficients of correlation should be applied.

The specimens should be sampled during manufacture, undergo the same heat treatment as the beams, and be stored in the same environment until the time of compressive strength testing.

NOTE The concrete strength at time of release of tendons may be determined by other methods (rebound hammer, sound velocity and maturity measurement) after correlation by means of laboratory tests.

J.1.2 Interpretation of results

After the time considered necessary for the concrete to have hardened sufficiently for prestressing to go ahead, the procedure described in Figure J.1 should be applied.

Other appropriate methods may also be applied provided the required minimum compressive strength, $f_{cmin,p}$, at release is as given in 4.2.3.2.3 of this standard.

The results should be recorded.

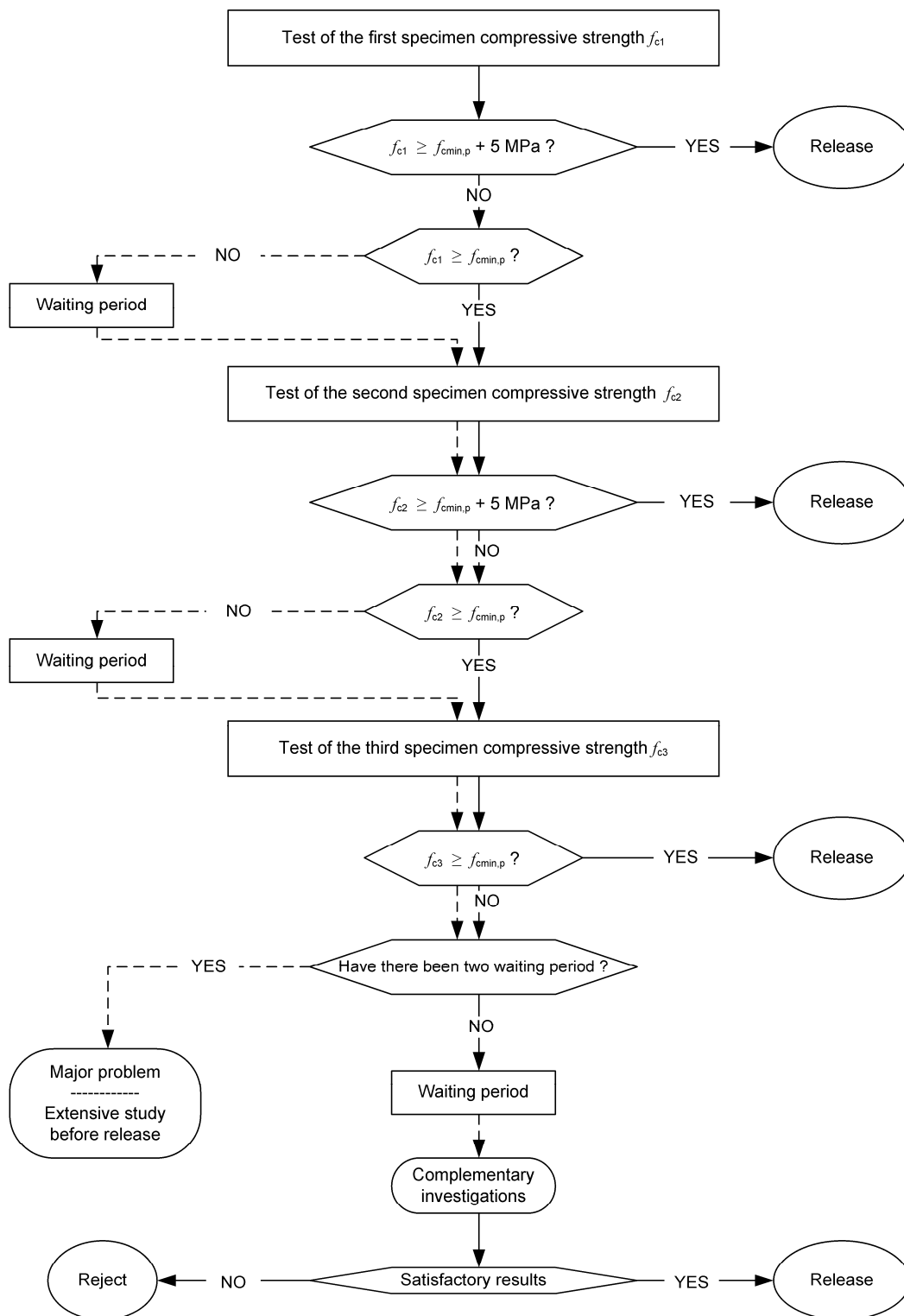

Figure J.1 — Tests procedure before release

Annex K (informative)

Resistance to fire

K.1 General

The constituent parts of beam-and-block floor systems should be such that the fire resistance of the finished floor system (bearing capacity and/or fire break value) is complied with for the period of time required by fire regulations, taking account of the intended purpose of the floor. Moreover, the constituent parts should neither be the origin of fire nor contribute to the spread of fire.

K.2 Fire resistance of beam-and-block floor systems

The fire resistance of beam-and-block floor systems should be determined by testing or by calculation or from tabulated data.

Verifications should be performed by testing or by calculation, or by both jointly.

K.3 Determination by testing

Fire resistance may be substantiated by taking account of the results of previous tests on floor systems similar to the floor system proposed, according to EN 1365-2.

If this is not possible (new systems or systems whose characteristics are significantly different to those of the systems tested previously), two tests should be carried out for each expected failure mode (bending failure, shear failure).

If, for a given type of test, the shorter recorded fire resistance time is less than 0,8 times the longer time, a third test should be performed.

The fire resistance to be declared is the minimum recorded time, unless the exceptionally low test result can be explained.

For a given type of floor system, the results obtained should be extrapolated to different resisting sections, spans, or load cases, with the provision that such extrapolation is substantiated by appropriate calculation methods.

NOTE If the results of the first test are at least 20 % higher than the required fire resistance time, a single test per failure type will be sufficient.

K.4 Evaluation by calculation

K.4.1 General

Resistance to fire should be determined by calculation according to EN 1992-1-2:2004. For the shear strength, the verification is not necessary.

The integrity criteria, is assumed to be verified if the topping is reinforced with a mesh.

K.4.2 Mechanical resistance

For the 15 min fire-stability rating, the floor system is assimilated to a solid slab.

For the 30 min and 60 min fire-stability rating, calculation of the temperatures in the bottom part of the beam (reinforcement) is carried out in two steps and distinguishes between blocks of different depths:

Blocks < 15 cm deep

The bottom ligament is assumed to remain intact for 15 min. The first 15 min are calculated by assimilating the blocks to a solid slab, and beyond 15 min the calculation considers the residual profile retaining the ligaments of the blocks in contact with the cast in-situ concrete topping (see Figure K.1).

Blocks \geq 15 cm deep

The bottom ligament is assumed to remain intact for 30 min. The first 30 min are calculated by assimilating the blocks to a hollow slab, and beyond 30 min the calculation considers the residual (see Figure K.1).



Figure K.1 — Retained residual profile (hatched section)

NOTE Beam-and-block floor systems with a protective coating of sufficient thickness on their underside, e_s , should be treated as solid slabs of a thickness equal to the total thickness of the floor system (but using its actual weight for the calculation of forces and moments), including the thickness of the coating (with its thermal properties) or equivalent thickness of the concrete (see Figure K.2).

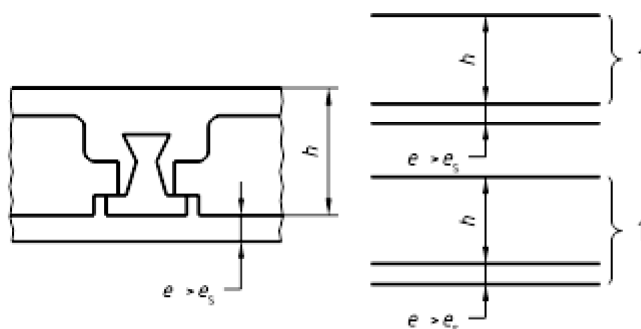

Key

1 Concrete

Figure K.2 — Equivalent thickness of the concrete

K.4.3 Additional protection

The required fire-resistance grading should be obtained by adding suitable protective materials that are properly bonded to the structure they protect. The bonding or attaching systems should be covered by conclusive testing.

These materials are characterized by their equivalent concrete thickness.

NOTE In the absence of tests proving the protection provided by these devices, the following equivalent values may be adopted:

- 1 cm of cement mortar : 0,67 cm of concrete;
- 1 cm of vermiculite : 2,5 cm of concrete;
- 1 cm of rock wool : 2,5 cm of concrete;
- 1 cm of ordinary gypsum plaster: 2,5 cm of concrete.

K.5 Tabulated data

For guidance, Table K.1 gives the minimum fire-resistance grades for the different current types of floor systems proposed in Annex B. These values were deduced from the results of tests performed on finished floor systems under dwelling loadings.

The fire-resistance grades referred to are defined by the following criteria:

- mechanical strength;
- thermal insulation (mean and maximum temperature rises of 140 °C and 180 °C, respectively, on the face not exposed to the fire);
- fire integrity and absence of emanation of flammable gases from the face exposed to the fire.

NOTE Continuity on support may be used in order to increase the fire resistance grade.

Table K.1 — Resistance grades for different composite floor types for dwellings with current beams (without gypsum plaster on lower face)

Floor types (see Annex B)	Fire resistance grade (in minutes)
Floor system with cast in-situ structural topping:	
— with polystyrene blocks ^a	30
— with hollow concrete or clay blocks	30
— with solid concrete or clay blocks	60
Floor system with composite topping	30
Floor system with partial topping (e.g. with floating screed)	30
Floor system with self-bearing beams	
— with polystyrene blocks	15
— with semi-resisting blocks	30
^a In the light of present knowledge on behaviour under fire conditions, these floor systems should be used exclusively as floors over crawl spaces.	

NOTE Higher fire resistance grade may be obtained by applying gypsum plaster on lower face of the floor.

Annex L (informative)

Acoustic insulation

L.1 General

Acoustic performances depend on the finished floor system. Without applied ceiling, and with or without plastering in lower face, beam-and-block floor systems get slightly lower acoustic insulation (up to 4 dB) than that of a solid slab with the same mass, depending on the hollows of the blocks.

L.2 Airborne sound insulation

Airborne sound insulation may, as an alternative to test results, be estimated from the mass per unit area as follows (in dB):

$$R_w = 40 \log(M_R) - 56 + \frac{3}{8} \left(\frac{M_R}{h_t} \right)$$

where:

M_R is the mass of the floor, in kg/m²

h_t is the depth of the floor, in cm (without taking into account the floor finishing or the floating slab)

L.3 Impact sound insulation

Impact sound insulation may, as an alternative to test results, be estimated from the mass per unit area as follows (in dB) :

— Floor with solid concrete blocks:

$$L_{n,w} = 165 - 35 \log(M_R)$$

— Floor with hollow blocks (concrete, clay, polystyrene, etc.):

$$L_{n,w} = 170 - 35 \log(M_{ep})$$

— Floor supporting a heavy floor finishing (e.g. concrete tiles) or a floating slab:

$$L_{n,w} = 170 - 35 \log(M_{ep} + M_s)$$

— Floor supporting a floating slab on a plastic film:

$$L_{n,w} = 170 - 35 \log(M_{ep} + M_s)$$

— Floor supporting a floating slab on a resilient layer:

$$L_{n,w} = L_{n,w \text{ floor}} - \Delta L_w$$

where:

M_R is the mass of the floor, in kg/m^2 ;

M_{ep} is the equivalent mass of the floor, in kg/m^2 ;

$M_{\text{ep}} = M_R - M_r$ with $M_r = 80 (h/H)$ for concrete and clay blocks and $M_r = 15$ for polystyrene blocks;

h height of the hollow block, in cm;

H total height of the floor, in cm;

M_s weight of the floor finishing or the floating slab, in kg/m^2 ;

ΔL_w weighted reduction of the impact sound level by the floor finishing, in dB.

$5 \text{ dB} < \Delta L_w \leq 35 \text{ dB}$ (from test results or by calculation according to EN 12354-2)

Annex Y (informative)

Choice of CE marking method

Y.1 General

The producer should choose to apply, for CE marking, one of the methods described in ZA.3, on the basis of the following conditions.

Y.2 Method 1

The declaration of geometrical data and material properties as specified in ZA.3.2 may be applied when the following condition occurs:

- off the shelf and catalogue products.

Y.3 Method 2

The declaration of product properties determined following this standard and EN Eurocodes, as specified in ZA.3.3, should be applied when the following condition occurs:

- precast product with product properties declared by the producer.

Y.4 Method 3

The declaration of compliance with a given specification as specified in ZA.3.4 may be applied when the following condition occurs:

- other cases than Y.2 and Y.3.

Annex ZA (informative)

Relationship between this European Standard and the Essential Requirements of EU Directive 89/109/EEC, EU Construction Products Directive

ZA.1 Scope and relevant characteristics

This European Standard has been prepared under the mandate M/100 "Precast Concrete Products" ²⁾ given to CEN by the European Commission and the European Free Trade Association.

The clauses of this European Standard shown in this annex meet the requirements of the mandate given under the EU Construction Products Directive (89/106/EEC).

Compliance with these clauses confers a presumption of fitness of the beams for beam-and-block floor systems covered by this annex for the intended uses indicated herein; reference should be made to the information accompanying the CE marking.

WARNING — Other requirements and other EU Directives, not affecting the fitness for intended uses, may be applicable to the beams for beam-and-block floor systems falling within the scope of this standard.

NOTE 1 In addition to any specific clauses relating to dangerous substances contained in this standard, there may be requirements applicable to the products falling within its scope (e.g. transposed European legislation and national laws, regulations and administrative provisions). In order to meet the provisions of the EU Construction Products Directive, these requirements need also to be complied with, when and where they apply.

NOTE 2 An informative database of European and national provisions on dangerous substances is available at the Construction web site on EUROPA (accessed through <http://europa.eu.int/comm/enterprise/construction/internal/dangsub/dangmain.htm>).

This annex establishes the conditions for CE marking of beams made of reinforced or prestressed concrete (with or without clay shell) for beam-and-block floor systems, used for the construction of the structures of buildings and other civil engineering works, except bridges and shows the relevant clauses applicable.

This annex has the same scope as Clause 1 of this standard and is defined by Table ZA.1.

2) as amended

Table ZA.1 — Relevant clauses for precast concrete beams used in beam-and-block floor systems

Essential characteristics		Requirement clauses in this Standard	Levels and/or class(es)	Notes and Unit
Compressive strength (of concrete)	All methods	4.2.1 Concrete Production and 4.2.2 Hardened concrete	None	N/mm ²
Ultimate tensile and tensile yield strength (of steel)	All methods	4.1.3 Reinforcing steel 4.1.4 Prestressing steel	None	N/mm ²
Mechanical strength (by calculation)	Method 1	Information listed in ZA.3.2	None	Geometry and materials
	Method 2	4.3.3 Mechanical resistance	None	kNm, kN, kN/m
	Method 3	Design specification	None	
Resistance to fire (for load bearing capacity)	Method 1	Information listed in ZA.3.2	R	Geometry and materials
	Method 2	4.3.4.1 Resistance to fire	R	Testing, tabulated data, calculation
	Method 3	Design specification	R	
Airborne sound insulation and impact noise transmission (when the product is intended also for acoustic applications)	All methods	4.3.5 Acoustic properties	None	dB
Detailing	All methods	4.3.1 Geometrical properties	None	mm
		4.3.2 Surface characteristics		Types
		8 Technical documentation		/
Durability	All methods	4.3.7 Durability	None	Ambient conditions

Method 1 = declaration of geometrical data and material properties (see ZA.3.2)

Method 2 = declaration of the value of the product properties (see ZA.3.3)

Method 3 = declaration of compliance with given design specification (see ZA.3.4)

The producer should select when he applies each method in accordance with Annex Y.

The requirement on a certain characteristic is not applicable in those Member States (MSs) where there are no regulatory requirements for that characteristic for the intended use of the product. In this case, manufacturers placing their products on the market of these MSs are not obliged to determine nor to declare the performance of their products with regard to this characteristic and the option “No performance determined” (NPD) in the information accompanying the CE marking (see ZA.3) may be used. The NPD option may not be used, however, where the characteristic is subject to a threshold level.

ZA.2 Procedure for attestation of conformity of beams for beam-and-block floor systems

ZA.2.1 System of attestation of conformity

The system of attestation of conformity of beams for beam-and-block floor systems, for the essential characteristics indicated in Table ZA.1, in accordance with the decision of the Commission 1999/94/EC of 25 January 1999 as given in Annex III of the Mandate M/100 "Precast concrete products", is shown in Table ZA.2, for the indicated intended use and relevant levels or classes:

Table ZA.2 — System of attestation of conformity

Products	Intended Uses	Levels or Classes	Attestation of Conformity systems
Beams for beam-and-block floor systems	Structural	–	2+
System 2+: See Directive 89/106 (CPD) Annex III-2 (ii) First possibility, including certification of the factory production control by an approved body on the basis of initial inspection of factory and of factory production control as well as of continuous surveillance, assessment and approval of factory production control.			

The attestation of conformity of beams for beam-and-block floor systems, for the essential characteristics indicated in Table ZA.1, should be based on the evaluation of conformity procedure indicated in Table ZA.3, resulting from the application of the clauses of this or other European Standards indicated therein.

Table ZA.3 — Assignment of evaluation of conformity tasks for beams for beam-and-block floor systems under system 2+

Tasks		Content of the tasks	Evaluation of conformity clauses to apply
Tasks for the manufacturer	Initial type testing	All characteristics of Table ZA.1 ^a	6.2 of EN 13369:2004
	Factory production control	Parameters related to all characteristics of Table ZA.1	6.3 of EN 13369:2004 and Annex A of this standard
	Further testing of samples taken at the factory	All characteristics of Table ZA.1 ^a	6.2.3 of EN 13369:2004
Tasks for the notified body	Certification of factory production control on the basis of:	Initial inspection of factory and of factory production control	6.1.3.2 a) and 6.3 of EN 13369:2004 and Annex A of this standard
		Continuous surveillance, assessments and approval of factory production control	6.1.3.2 b) and 6.3 of EN 13369:2004 and Annex A of this standard
^a For fire resistance (when verified by testing) tests should be carried out by testing laboratory.			

ZA.2.2 EC Certificate and Declaration of conformity

When compliance with the conditions of this annex is achieved, and once the notified body has drawn up the certificate mentioned below, the manufacturer or his agent established in the EEA should prepare and retain a declaration of conformity, which entitles the manufacturer to affix the CE marking. This declaration shall include:

- name and address of the manufacturer, or his authorised representative established in the EEA, and the place of production;

NOTE 1 The manufacturer may also be the person responsible for placing the product onto the EEA market, if he takes responsibility for CE marking.

- description of the product (type, identification, use, etc.), and a copy of the information accompanying the CE marking;

NOTE 2 Where some of the information required for the Declaration is already given in the CE marking information, it does not need to be repeated.

- provisions to which the product conforms (e.g. Annex ZA of this EN);
- particular conditions applicable to the use of the product (e.g. provisions for use under certain conditions, etc.);
- number of the accompanying factory production control certificate;
- name of, and position held by, the person empowered to sign the declaration on behalf of the manufacturer or his authorised representative.

The declaration shall be accompanied by a factory production control certificate, drawn up by the notified body, which shall contain, in addition to the information above, the following:

- name and address of the notified body;
- number of the factory production control certificate;
- conditions and period of validity of the certificate, where applicable;
- name of, and position held by, the person empowered to sign the certificate.

The above mentioned declaration and the certificate shall be presented in the official language or languages of the Member State in which the product is to be used.

ZA.3 CE marking and labelling

ZA.3.1 General

ZA.3.1.1 Affixing of CE marking

The manufacturer or his authorised representative established within the EEA is responsible for the affixing of the CE marking. The CE marking symbol to affix shall be in accordance with Directive 93/68/EC and shall be shown on the product (or when not possible it may be on the accompanying label, the packaging or on the accompanied commercial documents e.g. a delivery note).

The following information shall be added to the CE marking symbol:

- identification number of the certification body;
- name or identifying mark and registered address of the producer;
- last two digits of the year in which the marking is affixed;
- number of the EC factory production control certificate;
- reference to this European Standard;
- description of the product: generic name and intended use;
- information on those relevant essential characteristics taken from Table ZA.1 which are listed in the relevant clause ZA.3.2, ZA.3.3 or ZA.3.4;
- "No performance determined" for characteristics where this is relevant.

The "No performance determined" (NPD) option may not be used where the characteristic is subject to a threshold level. Otherwise, the NPD option may be used when and where the characteristic, for a given intended use, is not subject to regulatory requirements in the Member State of destination.

In the following subclauses the conditions are given for the application of CE marking. Figure ZA.1 gives the simplified label to affix to the product, containing the minimum set of information and the link to the accompanying document where the other required information are given. For what concerns the information on essential characteristics, some of them may be given by an unambiguous reference to:

- technical information (product catalogue) (see ZA.3.2);
- technical documentation (ZA.3.3);
- design specification (ZA.3.4).

The minimum set of information to be put directly in the affixed label or in the accompanying document is given in Figures ZA.2, ZA.3 and ZA.4.

ZA.3.1.2 Simplified label

In the case of simplified label the following information shall be added to the CE marking symbol:

- name or identifying mark and registered address of the producer;
- identification number of the unit (to ensure traceability);
- last two digits of the year in which the marking is affixed;
- number of the CE factory production control certificate;
- reference to this European Standard.

The same identification number shall mark, in the accompanying documents, the information related to the unit.

All other information defined by the relevant method of CE marking in one of the relevant clauses ZA.3.2, ZA.3.3 and ZA.3.4 shall be provided in the accompanying documents.

Figure ZA.1 gives the simplified label to affix to the product, containing the minimum set of information. The other information defined in ZA.3.1 and not given with the simplified label shall be provided with the accompanying documents.

	CE conformity marking consisting of the CE symbol given in Directive 93/68/EEC
AnyCo Ltd, PO Bx 21, B-1050	Name or identifying mark and registered address of the producer
45PJ76/07	Identification number and last two digits of the year in which the marking was affixed
0123-CPD-0456	Number of the FPC certificate
EN 15037-1	Number of this European Standard

Figure ZA.1 — Example of simplified label

NOTE For small elements or for product stamping reasons, the size can be reduced by removing reference to EN and/or to FPC certificate.

ZA.3.2 Declaration of geometrical data and material properties

(Method 1 to determine properties relating to essential requirements "mechanical resistance and stability" and "resistance to fire".)

Figure ZA.2 gives, for a type of beams for beam-and-block floor systems, the model CE marking inclusive of the information needed to determine, according to design regulation valid in the place of use, the properties related to mechanical resistance and stability and resistance to fire, including aspects of durability and serviceability.

Referring to Table ZA.1 and to the information quoted in the list of ZA.3.1, the following properties shall be declared:

- compressive strength of concrete;
- ultimate tensile strength of reinforcing steel;
- tensile yield strength of reinforcing steel;
- ultimate tensile strength of prestressing steel;
- tensile 0,1 proof stress of prestressing steel;
- geometrical data (only critical dimensions);
- conditions for durability;
- possible reference to Technical Information (product catalogue) for detailing, durability and geometrical data.

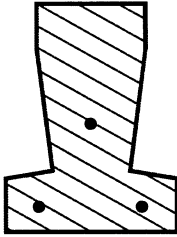
 0123
AnyCo Ltd, PO Bx 21, B-1050 07 0123-CPD-0456
EN 15037-1 Beams for beam-and-block floor systems PRESTRESSED BEAMS Concrete: Compressive strength $f_{ck} = 50 \text{ N/mm}^2$ Prestressing steel: Ultimate tensile strength..... $f_{pk} = 2\,060 \text{ N/mm}^2$ Tensile 0,1 % proof-stress $f_{p0,1k} = 1\,840 \text{ N/mm}^2$  Measures in mm Length $L = (5\,500 \pm 25) \text{ mm}$ Strands 3xY2060W3-5,2 Initial stress $\sigma_{pi} = 1\,750 \text{ N/mm}^2$ End protrusion of strands $l = 10 \text{ mm}$ For detailing and durability see Technical Information Technical Information: Product Catalogue ABC:2002 – clause ii

CE conformity marking consisting of the CE symbol given in Directive 93/68/EEC

Identification of the notified body

Name or identifying mark and registered address of the producer

Last two digits of the year in which the marking was affixed

Number of the FPC certificate

Number and title of European Standard concerned

Generic name and intended use

Information on product geometry and material characteristics including detailing (to be adapted to the specific product by the producer)

NOTE 1 Numerical values are only as example.

NOTE 2 The sketch may be omitted if equivalent information are available in clearly identified Technical Information (product catalogue) referred to

Figure ZA.2 — Example of CE marking with Method 1

ZA.3.3 Declaration of product properties

(Method 2 to determine properties relating to essential requirements "mechanical resistance and stability" and "resistance to fire".)

For all design data, including models and parameters used in calculation, reference may be made to the technical (design) documentation.

Referring to Table ZA.1 and to the information quoted in the list of ZA.3.1, the following properties shall be declared:

- compressive strength of concrete;
- ultimate tensile strength of reinforcing steel;
- tensile yield strength of reinforcing steel;
- ultimate tensile strength of prestressing steel;
- tensile 0,1 proof stress of prestressing steel;
- mechanical ultimate strength of the element (design values for transient situations) with bending moment capacity and shear capacity of critical sections;
- safety factors for concrete and steel used in calculation;
- resistance to fire R class according to the relevant blocks;
- airborne sound insulation index and impact noise transmission index (only when the product is intended also for acoustic applications);
- other Nationally Determined Parameters NDPs used in calculation;
- conditions for durability;
- possible reference to Technical Documentation for geometrical data, detailing, durability, other NDPs, acoustic insulation parameters and thermal resistance.

Figure ZA.3 gives, for prestressed or reinforced beams for beam-and-block floor systems, the model CE marking in the case in which the properties related to mechanical resistance and stability and resistance to fire are determined by means of EN Eurocodes.

The design values of the mechanical ultimate strength of the element and the resistance to fire class shall be computed using, for the Nationally Determined Parameters, either the values recommended in EN 1992-1-1 and EN 1992-1-2 or the values given in the National Annex of the Eurocodes applicable to the works.

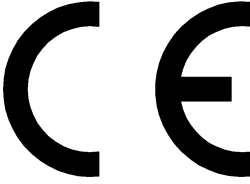
 0123
AnyCo Ltd, PO Bx 21, B-1050 07 0123-CPD-0456
<p style="text-align: center;">EN 15037-1</p> <p style="text-align: center;">Beams for beam-and-block floor systems</p> <p style="text-align: center;">PRESTRESSED/REINFORCED BEAMS</p> <p>Concrete:</p> <p>Compressive strength f_{ck} = xxx N/mm²</p> <p>Reinforcing steel:</p> <p>Ultimate tensile strength..... f_{tk} = yyy N/mm²</p> <p>Tensile yield strength f_{yk} = zzz N/mm²</p> <p>Prestressing steel:</p> <p>Ultimate tensile strength..... f_{pk} = uuu N/mm²</p> <p>Tensile 0,1% proof-stress $f_{p0,1K}$ = www N/mm²</p> <p>Mechanical resistance (design values):</p> <p>Bending moment capacity (of the middle section)..... uuu kN</p> <p>Shear capacity (of the end sections)..... www kN</p> <p>Resistance to fire R..... RXX for $\eta_{fi} = 0.xx$ RYY for $\eta_{fi} = 0.yy$</p> <p>For geometrical data, detailing, durability, acoustic insulation index, possible complementary information on fire resistance and other NDPs see the Technical documentation</p> <p>Technical documentation: Position number xxxxxx</p>

CE conformity marking consisting of the CE symbol given in Directive 93/68/EEC

Identification of the notified body

Name or identifying mark and registered address of the producer

Last two digits of the year in which the marking was affixed

Number of the FPC certificate

Number and title of European Standard concerned

Generic name and intended use

Information on product mandated characteristics including detailing (to be adapted to the specific product by the producer)

Figure ZA.3 — Example of CE marking with Method 2

ZA.3.4 Declaration of compliance with a given design specification

(Method 3 to determine properties relating to essential requirements "mechanical resistance and stability" and "resistance to fire".)

The Method 3 applies in the following situations:

- a) For cases in which the beam is produced in accordance with the design details (drawings, material specifications, etc.) prepared by the designer of the works ³⁾ following the National Provisions, component hENs or ETAs shall provide, where relevant, that the information to accompany the CE marking with regard to the product properties can be given by making reference, in an unambiguous way, to the respective design documents of the works.
- b) For cases in which the producer has designed and produced a beam following the provisions of the client's order, in accordance with the National Provisions applicable to the works, the component hEN or ETA shall provide, where relevant, that the information to accompany the CE marking with regard to the product properties can be given by making reference, in an unambiguous way, to the drawings and material specifications linked to the client's order.

Figure ZA.4 gives, for prestressed or reinforced beams for beam-and-block floor systems, the model CE marking in the case the product is produced according to a design specification in which the properties related to mechanical resistance and stability and resistance to fire are determined by means of design provisions applicable to the works. This applies both for design specification prepared by the designer of the works (case a) or by the producer (case b).

Referring to Table ZA.1 and to the information quoted in the list of ZA.3.1, the following properties shall be declared:

- compressive strength of concrete;
- ultimate tensile strength of reinforcing steel;
- tensile yield strength of reinforcing steel;
- ultimate tensile strength of prestressing steel;
- tensile 0,1 proof stress of prestressing steel.

This method applies also in case of a design made with means other than EN Eurocodes.

3) or the designer of the concerned part of the works

 0123
AnyCo Ltd, PO Bx 21, B-1050 07 0123-CPD-0456
EN 15037-1 Beams for beam-and-block floor systems PRESTRESSED/REINFORCED BEAMS Concrete: Compressive strength f_{ck} = xx N/mm ² Reinforcing steel : Ultimate tensile strength..... f_{tk} = yyy N/mm ² Tensile yield strength f_{yk} = zzz N/mm ² Prestressing steel: Ultimate tensile strength..... f_{pk} = uuu N/mm ² Tensile 0,1% proof-stress $f_{p0,1K}$ = www N/mm ² For geometrical data, detailing, mechanical strength, fire resistance, acoustic insulation index and durability see the design specifications Design specification: Order codexxxxxx

CE conformity marking consisting of the CE symbol given in Directive 93/68/EEC

Identification of the notified body

Name or identifying mark and registered address of the producer

Last two digits of the year in which the marking was affixed

Number of the FPC certificate

Number and title of European Standard concerned

Generic name and intended use

Information on product mandated characteristics including detailing (to be adapted to the specific product by the producer)

Figure ZA.4 — Example of CE marking with Method 3

In addition to any specific information relating to dangerous substances, the product should be also accompanied, when and where required and in the appropriate form, by documentation listing any other legislation on dangerous substances for which compliance is claimed, together with any information required by that legislation.

NOTE 1 European legislation without national derogations need not be mentioned.

NOTE 2 Affixing the CE marking symbol means, if a product is subject to more than one directive that it complies with all applicable directives.

Bibliography

- [1] EN 1365-2, *Fire resistance tests for loadbearing elements — Part 2: Floors and roofs.*
- [2] EN 1991-1-1:2002, *Eurocode 1: Actions on structures — Part 1-1: General actions — Densities, self weight, imposed loads for buildings*
- [3] EN 1998, *Eurocode 8: Design of structures for earthquake resistance*
- [4] EN 12354-2, *Building acoustics — Estimation of acoustic performance of buildings from the performance of elements — Part 2: Impact sound insulation between rooms*
- [5] EN 13225, *Precast concrete products — Linear structural elements*
- [6] prEN 15037-4, *Precast concrete products — Beam-and-block floor systems — Part 4: Polystyrene blocks*
- [7] prEN 15037-5, *Precast concrete products — Beam-and-block floor systems — Part 5: Lightweight blocks*

BSI — British Standards Institution

BSI is the independent national body responsible for preparing British Standards. It presents the UK view on standards in Europe and at the international level. It is incorporated by Royal Charter.

Revisions

British Standards are updated by amendment or revision. Users of British Standards should make sure that they possess the latest amendments or editions.

It is the constant aim of BSI to improve the quality of our products and services. We would be grateful if anyone finding an inaccuracy or ambiguity while using this British Standard would inform the Secretary of the technical committee responsible, the identity of which can be found on the inside front cover.
Tel: +44 (0)20 8996 9000. Fax: +44 (0)20 8996 7400.

BSI offers members an individual updating service called PLUS which ensures that subscribers automatically receive the latest editions of standards.

Buying standards

Orders for all BSI, international and foreign standards publications should be addressed to Customer Services. Tel: +44 (0)20 8996 9001.
Fax: +44 (0)20 8996 7001. Email: orders@bsi-global.com. Standards are also available from the BSI website at <http://www.bsi-global.com>.

In response to orders for international standards, it is BSI policy to supply the BSI implementation of those that have been published as British Standards, unless otherwise requested.

Information on standards

BSI provides a wide range of information on national, European and international standards through its Library and its Technical Help to Exporters Service. Various BSI electronic information services are also available which give details on all its products and services. Contact the Information Centre.
Tel: +44 (0)20 8996 7111. Fax: +44 (0)20 8996 7048. Email: info@bsi-global.com.

Subscribing members of BSI are kept up to date with standards developments and receive substantial discounts on the purchase price of standards. For details of these and other benefits contact Membership Administration.
Tel: +44 (0)20 8996 7002. Fax: +44 (0)20 8996 7001.
Email: membership@bsi-global.com.

Information regarding online access to British Standards via British Standards Online can be found at <http://www.bsi-global.com/bsonline>.

Further information about BSI is available on the BSI website at <http://www.bsi-global.com>.

Copyright

Copyright subsists in all BSI publications. BSI also holds the copyright, in the UK, of the publications of the international standardization bodies. Except as permitted under the Copyright, Designs and Patents Act 1988 no extract may be reproduced, stored in a retrieval system or transmitted in any form or by any means – electronic, photocopying, recording or otherwise – without prior written permission from BSI.

This does not preclude the free use, in the course of implementing the standard, of necessary details such as symbols, and size, type or grade designations. If these details are to be used for any other purpose than implementation then the prior written permission of BSI must be obtained.

Details and advice can be obtained from the Copyright & Licensing Manager.
Tel: +44 (0)20 8996 7070. Fax: +44 (0)20 8996 7553.
Email: copyright@bsi-global.com.