

Facilities for users of roller sports equipment — Safety requirements and test methods

The European Standard EN 14974:2006 has the status of a
British Standard

ICS 97.220.10

National foreword

This British Standard was published by BSI. It is the UK implementation of EN 14974:2006. It supersedes PAS 35:2002 which is withdrawn.

The UK participation in its preparation was entrusted to Technical Committee SW/65, Children's playground equipment.

A list of organizations represented on SW/65 can be obtained on request to its secretary.

It should be noted that the UK voted in favour of the publication of this standard, however it does not entirely concur with all of its content. Specifically, the UK objected to the maximum permissible upward coping projection as specified in Clause 5.1.2.6. The UK recommended a maximum value of 12mm vice 30mm.

This publication does not purport to include all the necessary provisions of a contract. Users are responsible for its correct application.

Compliance with a British Standard cannot confer immunity from legal obligations.

This British Standard was published under the authority of the Standards Policy and Strategy Committee on 30 March 2007

© BSI 2007

ISBN 978 0 580 50365 8

Amendments issued since publication

Amd. No.	Date	Comments

ICS 97.220.10

English Version

Facilities for users of roller sports equipment - Safety requirements and test methods

Installations pour sports à roulettes et vélos bicross -
Exigences de sécurité et méthodes d'essai

Anlagen für Benutzer von Rollsportgeräten -
Sicherheitstechnische Anforderungen und Prüfverfahren

This European Standard was approved by CEN on 24 May 2006.

CEN members are bound to comply with the CEN/CENELEC Internal Regulations which stipulate the conditions for giving this European Standard the status of a national standard without any alteration. Up-to-date lists and bibliographical references concerning such national standards may be obtained on application to the Central Secretariat or to any CEN member.

This European Standard exists in three official versions (English, French, German). A version in any other language made by translation under the responsibility of a CEN member into its own language and notified to the Central Secretariat has the same status as the official versions.

CEN members are the national standards bodies of Austria, Belgium, Cyprus, Czech Republic, Denmark, Estonia, Finland, France, Germany, Greece, Hungary, Iceland, Ireland, Italy, Latvia, Lithuania, Luxembourg, Malta, Netherlands, Norway, Poland, Portugal, Romania, Slovakia, Slovenia, Spain, Sweden, Switzerland and United Kingdom.



EUROPEAN COMMITTEE FOR STANDARDIZATION
COMITÉ EUROPÉEN DE NORMALISATION
EUROPÄISCHES KOMITEE FÜR NORMUNG

Management Centre: rue de Stassart, 36 B-1050 Brussels

Contents

	Page
Foreword.....	3
Introduction	4
1 Scope	5
2 Normative references	5
3 Terms and definitions	6
4 Material	7
4.1 General.....	7
4.2 Timber and associated products	7
4.2.1 General.....	7
4.2.2 Solid wood.....	8
4.2.3 Laminated wood.....	8
4.2.4 Plywood panel.....	8
4.2.5 Oriented strand boards	8
4.2.6 Particle boards (chipboards).....	8
4.3 Metals.....	8
4.4 Polymer-based composites	8
4.5 Concrete	9
4.6 Other materials.....	9
4.7 Fastenings	9
4.7.1 General.....	9
4.7.2 Bonding	9
4.7.3 Metal fastenings.....	9
5 Safety requirements	9
5.1 General requirements.....	9
5.1.1 General.....	9
5.1.2 Design/construction	10
5.2 Specific requirements for different facilities for users of roller sports equipment	13
5.2.1 General.....	13
5.2.2 Curb.....	13
5.2.3 Ledge	14
5.2.4 Rail	14
5.2.5 Jump ramp.....	15
5.2.6 Platform bank	16
5.2.7 Platform transition.....	16
5.2.8 Spine ramp	17
5.2.9 Wall ramp.....	18
5.2.10 Pyramid bank	19
5.2.11 Stair	19
5.2.12 Pipe	19
5.2.13 Fun box	21
5.3 Safety zones	22
5.3.1 General.....	22
5.3.2 Special requirements for safety zones	23
6 Testing	23
7 Marking	24
8 Information supplied by the manufacturer	24
8.1 General.....	24
8.2 Installation	24
8.3 Inspection and maintenance	24
9 Information for users.....	25

Foreword

This document (EN 14974:2006) has been prepared by Technical Committee CEN/TC 136 “Sports, playground and other recreational equipment”, the secretariat of which is held by DIN.

This European Standard shall be given the status of a national standard, either by publication of an identical text or by endorsement, at the latest by December 2006, and conflicting national standards shall be withdrawn at the latest by December 2006.

According to the CEN/CENELEC Internal Regulations, the national standards organizations of the following countries are bound to implement this European Standard: Austria, Belgium, Cyprus, Czech Republic, Denmark, Estonia, Finland, France, Germany, Greece, Hungary, Iceland, Ireland, Italy, Latvia, Lithuania, Luxembourg, Malta, Netherlands, Norway, Poland, Portugal, Romania, Slovakia, Slovenia, Spain, Sweden, Switzerland and United Kingdom.

Introduction

The use of facilities for users of roller sports equipment is connected with sporting risks. Sporting skills and the use of appropriate protective equipment essentially reduces the risk of accident.

It is not the intention of this standard to specify every possible shape and construction of facilities for users of roller sports equipment.

For supervised practices, facilities for users of roller sports equipment (competitions, demonstrations, training and initiation) having different dimensions and thus also increased risks, are also acceptable within the frame of legal provisions (e.g. regional building regulations).

The development of facilities for users of roller sports equipment is in constant evolution, therefore, some specific structures are not considered in this European Standard. For all such structures the general requirements apply.

This European Standard does not specify specific requirements for combinations.

1 Scope

This standard applies to facilities for users of inline-skates, roller skates, skateboards or similar roller sports equipment, as well as BMX cycles (hereinafter referred to as facility/facilities).

It specifies general and specific requirements and test methods for facilities used in unsupervised areas.

The purpose of this European Standard is to specify the safety requirements, which to a large extent protect users and third parties (e.g. spectators) from hazards when using a facility as intended or as can be reasonably expected.

2 Normative references

The following referenced documents are indispensable for the application of this document. For dated references, only the edition cited applies. For undated references, the latest edition of the referenced document (including any amendments) applies.

EN 59, *Glass reinforced plastics - Measurement of hardness by means of a Barcol impressor.*

EN 206-1, *Concrete - Part 1: Specification, performance, production and conformity*

EN 300:1997, *Oriented Strand Boards (OSB) - Definitions, classification and specifications*

EN 301, *Adhesives, phenolic and aminoplastic, for load-bearing timber structures - Classification and performance requirements*

EN 312, *Particleboards - Specifications*

EN 335-1:1992, *Durability of wood and wood-based products - Definition of hazard classes of biological attack - Part 1: General*

EN 338:2003, *Structural timber - Strength classes*

EN 351-1, *Durability of wood and wood-based products - Preservative-treated solid wood - Part 1: Classification of preservative penetration and retention*

EN 599-1, *Durability of wood and wood-based products - Performance of preventive wood preservatives as determined by biological tests - Part 1: Specification according to hazard class*

EN 636, *Plywood - Specifications*

EN 789, *Timber structures - Test methods - Determination of mechanical properties of wood based panels*

EN ISO 5470-1, *Rubber- or plastics-coated fabrics - Determination of abrasion resistance - Part 1: Taber abrader (ISO 5470-1:1999)*

EN ISO 12944-5, *Paints and varnishes - Corrosion protection of steel structures by protective paint systems - Part 5: Protective paint systems (ISO 12944-5:1998)*

ENV 1099, *Plywood - Biological durability - Guidance for the assessment of plywood for use in different hazard classes*

3 Terms and definitions

For the purposes of this European Standard, the following terms and definitions apply.

3.1

facility for users of roller sports equipment

structure and necessary area designated for users of roller sports equipment including inline-skates, roller skates, skateboards or similar roller sports equipment, as well as BMX cycles

3.2

structure

sports equipment having a solid surface on which the user of skateboards, roller skates, inline skates or similar roller sports equipment as well as BMX cycles can manoeuvre freely

3.3

ramp

structure incorporating one or more transitions and/or banks

3.4

transition

curved part of the riding surface

3.5

riding surface

part of the structure intended for grinding, sliding and rolling

3.6

rolling surface

part of the structure intended for rolling

3.7

grinding surface

part of the structure intended for grinding and sliding

3.8

extension

raised, horizontal portion of the platform which permits continuation of the rolling surface passed the lower portion of the platform

3.9

vert

vertical part of the rolling surface at the top of transition

3.10

coping

circular tube or section of a circular tube, which is firmly attached to the top of the riding surface

3.11

safety zone

space around a structure necessary for the safety of the user as well as third parties

3.12

run-up zone

space which is required to access a structure on roller sports equipment

3.13

free-fall height

vertical distance between the supporting surfaces and an adjoining horizontal surface located at a lower level

NOTE Supporting surfaces are horizontal riding surfaces and surfaces intended for standing. Exceptions are described in relevant sub-clauses of Clause 5.

3.14**platform**

horizontal surface on a structure provided with a barrier

3.15**run-out zone**

space required to exit a structure on roller sports equipment

3.16**foot**

part of the rolling surface located at a junction with the ground

3.17**barrier**

construction which prevents the user and/or roller sports equipment from falling from a height

3.18**table**

horizontal surface on a structure without a barrier

3.19**bank**

straight inclined part of the riding surface

3.20**table edge**

part of the rolling surface located at a junction with the table

3.21**board**

optional vertical wall located along the lateral edges of the rolling surface on a pipe

3.22**fastening**

mechanical load bearing component joining materials, parts and structures to withstand extreme vibrations and extreme temperatures

4 Material

4.1 General

The materials shall be selected in such a manner that the construction of a structure of any element manufactured from these materials meets the requirements of this standard.

Indoor structures shall comply with current Fire safety regulations.

The requirements in 4.2 and 4.3 relating to resistance to weather conditions may be neglected if the facility is installed in indoor or covered areas.

No substance that can adversely affect health shall be present in the facility.

NOTE The restrictions on the marketing and use of certain dangerous substances and preparations are ruled by the European Council Directive 76/769/EEC of the 27th July 1976 and its Amendments.

4.2 Timber and associated products

4.2.1 General

Building elements made of wood which touch the ground, shall be protected against rotting.

EN 14974:2006 (E)

NOTE When selecting metal fastenings, consideration should be given to the species of timber and chemical treatments used, as some will accelerate corrosion of certain metals if there is contact.

Timber components shall be designed so that rain shall drain or drop freely from the structure.

4.2.2 Solid wood

If it is in contact with the ground, solid wood shall meet the biological attack requirements of hazard class 4 according to EN 335-1:1992, or of hazard class 3, if it is at least over 200 mm from the ground. This natural or conferred durability of solid wood shall meet the levels required by EN 351-1 and EN 599-1.

For structural use solid wood shall be of at least class C 24 according to EN 338:2003.

4.2.3 Laminated wood

Laminated wood shall comply with the requirements of hazard class 2 for indoor use and of hazard class 3 for outdoor use in accordance with EN 335-1:1992. Laminate wood shall be of structural quality with bondings taking into account the intended indoor or outdoor use.

4.2.4 Plywood panel

Plywood panels shall meet the biological attack requirements of hazard class 2 for indoor use and of hazard class 3 for outdoor use according to EN 335-1:1992 and ENV 1099.

For structural use and climatic resistance, the requirements for structural panels according to EN 636 shall be met. The longitudinal modulus of elasticity and shear stress (mean value in each direction) and bending compressive and shear strength (characteristic value in each direction), shall be specified according to EN 789.

4.2.5 Oriented strand boards

Oriented strand boards shall meet the biological attack requirements of hazard class 2 for indoor use according to EN 335-1:1992.

For structural use the requirements of class OSB 4 are to be met according to EN 300:1997. In addition its mechanical properties, measured in accordance with EN 789, shall be defined.

4.2.6 Particle boards (chipboards)

Particle boards shall only be used for indoor facilities. They shall meet the biological attack requirements of hazard class 2 according to EN 335-1:1992.

For structural use particle boards shall comply with EN 312.

4.3 Metals

Metal components shall be resistant to weathering under atmospheric conditions. See also EN ISO 12944-5.

4.4 Polymer-based composites

When conducting the tests in accordance with EN ISO 5470-1, the layer situated beneath the gelcoat shall not be visible. The thickness of the gelcoat shall be at least 0,3 mm.

When conducting tests in accordance with EN 59, all types of polymer surfaces shall meet a Barcol hardness level equal to at least 40.

If, during the course of maintenance it is difficult to determine when the material becomes brittle, the manufacturers shall indicate a period of time after which the part or equipment should be replaced.

4.5 Concrete

4.5.1 Concrete mix and reinforcement shall comply with EN 206-1.

4.5.2 Concrete used for riding surfaces and foundations shall be at least in accordance with Table 1.

Table 1 — Types of concrete to be used

Concrete used for	Application area	Type of concrete
Riding surfaces	Outdoor	C 35/45
Riding surfaces	Indoor	C 25/30
Foundations	Outdoor and indoor	C 16/20

4.6 Other materials

The use of other materials is acceptable provided their suitability has been sufficiently proven by the supplier and/or manufacturer.

4.7 Fastenings

4.7.1 General

The complete fastening system shall be protected against corrosion.

NOTE This protection can be achieved for example, by galvanising or equivalent procedures.

4.7.2 Bonding

Glues used shall comply with the requirements of EN 301. They shall be chosen as a function of the environment in which the construction is installed.

4.7.3 Metal fastenings

Smooth tacks and nails shall not be used.

5 Safety requirements

5.1 General requirements

5.1.1 General

5.1.1.1 Where facilities for users of roller sports equipment are erected in combination with playgrounds, sports grounds, holiday parks and similar establishments, they have to be physically separated by an appropriate distance, fence or other constructional measures from the general playing activities.

5.1.1.2 All external accessible edges shall be chamfered with a radius of at least 3 mm.

5.1.1.3 The difference between the levels of the ground (see 5.1.2.2) and of the foot shall not exceed 5 mm measured from the top of the foot.

5.1.1.4 It shall not be possible to dismantle structures without tools.

5.1.1.5 Structures shall be screwed together or be securely joined by other means, or fixed to the ground to prevent displacement.

5.1.1.6 The external accessible parts of the structure shall not protrude any pointed parts, e. g. screws, splinters.

5.1.1.7 The ends of all the tubular parts including the coping shall be blanked off.

5.1.1.8 Platforms shall not be fitted with access stairs or ladders.

5.1.1.9 The free fall height of the riding, grinding and rolling surface shall not exceed 1 500 mm. For exceptions, see relevant sub-clauses under 5.2. The free fall height is to be measured 1 000 mm horizontally from the perimeter line of the supporting surface to the adjoining surface located at a lower level.

5.1.1.10 When a structure is provided with an extension, the height to be taken as a basis for calculation of the necessary width of the structure shall be the height of the highest platform or table. If the difference in height between platforms is less than 500 mm and less than $\frac{1}{3}$ of the total width, the width requirement only applies to the lower portion of the structure.

5.1.1.11 The foot shall not meet the ground at an angle greater than 30° . A transition shall not meet the ground at an angle greater than 15° .

5.1.1.12 If different structures are combined, each of them shall also meet at least the requirements of this standard. These combinations shall meet at least the general requirements of this standard.

5.1.2 Design/construction

5.1.2.1 Structural integrity and stability

Structures shall be designed with sufficient stability. They shall not tilt or wobble in a way that would be hazardous.

Structures shall be firmly fixed to the ground or be secured against displacement either by their own weight or by anchoring.

All riding surfaces of the facility shall be constructed to withstand a vertical force of $3,5 \text{ kN/m}^2$. Additionally, all riding surfaces shall be constructed to withstand a force of $7,0 \text{ kN}$ applied perpendicularly to the tangent at the rolling surface, over a surface area of $50 \text{ mm} \times 50 \text{ mm}$. The mounted structure is to be tested according to Clause 6. After testing the structure shall not have a permanent deformation or break. A permanent deformation is considered excessive when it infringes upon any other requirement of this standard.

The structures installed in accordance with the manufacturer's instructions shall withstand without any displacement or toppling over, a horizontal force F of $1,5 \text{ kN/m}$ applied in the middle of the highest part of the rolling surface in the direction of use (see Figure 1).

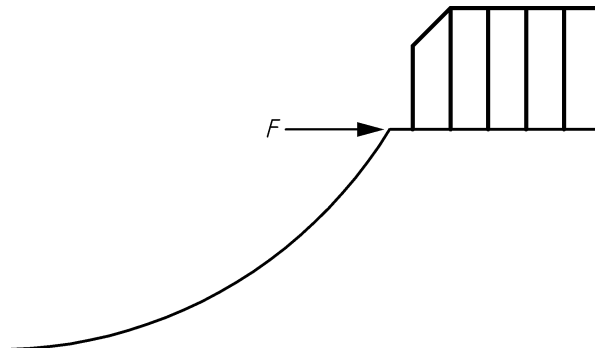

Figure 1 — Application of the horizontal force

Calculation can be disregarded where, according to construction and type of material, it is obviously not necessary or has been sufficiently proven by practical testing.

5.1.2.2 Ground

The ground on which the individual structure shall be located shall:

- a) be correctly level to prohibit the structure from rocking;
- b) have a 180° level where the foot meets the ground to enable compliance with the general requirements specified in 5.1.1.

The bearing capacity of the ground shall be ensured by foundations or other measures according to indications by the manufacturer.

5.1.2.3 Rolling surface

The rolling surface shall be even and closed. Mounting parts shall not project.

Any possible differences in height due to e.g. misalignment of edges, shall be smaller than the material thickness of the rolling surface and shall not exceed 3 mm.

Where the rolling surface consists of multiple layers of various materials the layers shall not become detached from each other.

Openings due to the different levels shall be closed. For rolling surfaces placed side by side, lateral openings shall be closed.

The width of joints shall not exceed 5 mm. Rolling surfaces shall be free-draining. Both requirements also apply to surfaces of surrounding areas intended to be used for riding.

5.1.2.4 Grinding surface

Edges designed for grinding and sliding shall be resistant to wear and tear caused by use of roller sports equipment and BMX cycles.

5.1.2.5 Barriers

The height of the barrier shall be at least 1 200 mm and this height shall be reached at a maximum distance of 200 mm from the front of the barrier.

For extensions, the barrier height at the upper part of the platform shall be extended at least 1 000 mm horizontally over the bottom part of the platform.

Barriers shall be constructed in order to withstand a horizontal force of 1 500 N/m. This requirement is met if no damages or permanent deformation impairing the performance or function occurs during testing in accordance with Clause 6.

No horizontal opening within a barrier shall have a dimension greater than 89 mm. Barrier ends, which project into the free space shall be radiused 100 mm minimum.

Barriers shall be designed so that they do not induce anyone to climb.

The distance between the top of the platform and the lower edge of the barrier shall not exceed 60 mm.

5.1.2.6 Copings

The diameter of copings shall be at least 40 mm.

The ends of the coping shall be sealed.

When two copings are used they shall be arranged parallel to one another (see Figure 2) and dimensions in accordance with Table 2 shall apply.

Where a coping is constructed of more than one piece, the joints shall not create a different level or a gap exceeding 2 mm.

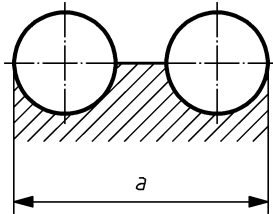

Figure 2 — Copings arranged in parallel

Table 2 — Dimensions of copings arranged in parallel

a mm
140 maximum
or 200 to 320
or 450 minimum

Where the distance between two copings is greater than 8 mm, the space shall be designed so that it is completely closed from the axis of the tubes.

The coping shall present a minimum projection of 3 mm forward and upward, a maximum projection of 12 mm forward and 30 mm upward (see Figure 3).

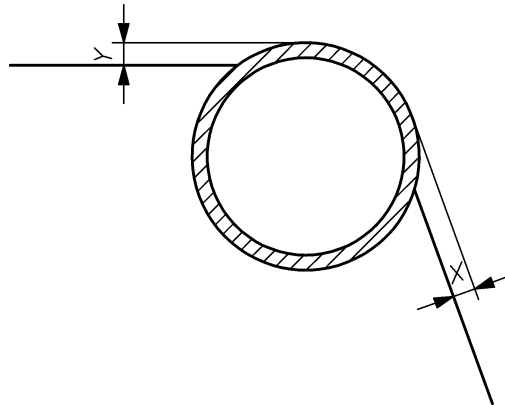

Key

$3 \text{ mm} \leq X \leq 12 \text{ mm}$

$3 \text{ mm} \leq Y \leq 30 \text{ mm}$

Figure 3 — Projection of the coping

5.1.2.7 Board

The board shall be smooth and continuously closed on the inner side.

It shall withstand a horizontal force of 2 kN/m applied at the upper edge. This requirement is considered as met, if no cracks, fractures or other permanent deformations impairing the function of the board have occurred during testing in accordance with Clause 6 (like in the case of protections against falling). The board shall have no door and shall extend over the entire rolling surface.

The height above the ground of the board shall be continuous across the length of the pipe and shall be at least 1 200 mm above the platform height.

5.2 Specific requirements for different facilities for users of roller sports equipment

5.2.1 General

Facilities for users of roller sports equipment are not limited to the pictorial representations in this European Standard. Only the specified dimensions and requirements have to be met.

5.2.2 Curb

The curb (see Figure 4) simulates a kerbstone and enables e.g. grinding. Dimensions of a curb see Table 3.

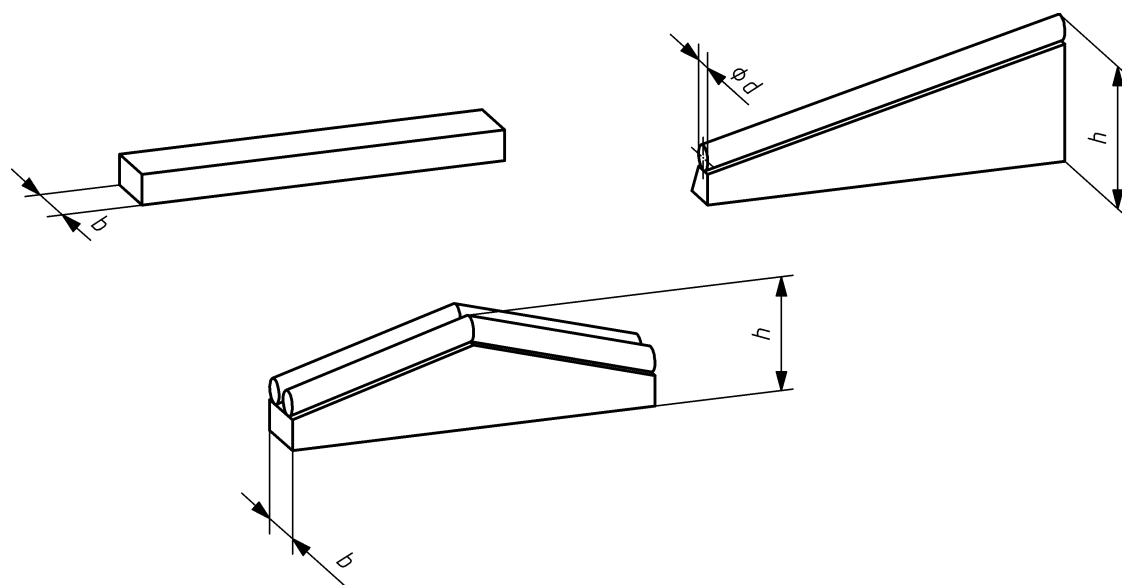

Figure 4 — Examples of curbs

Table 3 — Dimensions of curbs

Width b or diameter d mm	Height h mm
minimum 40	maximum 1 000

The side faces and the entire structure below the grinding surface shall be closed.

If there is an adjacent rolling surface it shall have a width of at least 1 200 mm.

5.2.3 Ledge

The ledge (see Figure 5) is a specific type of curb. Dimensions of a ledge see Table 4.

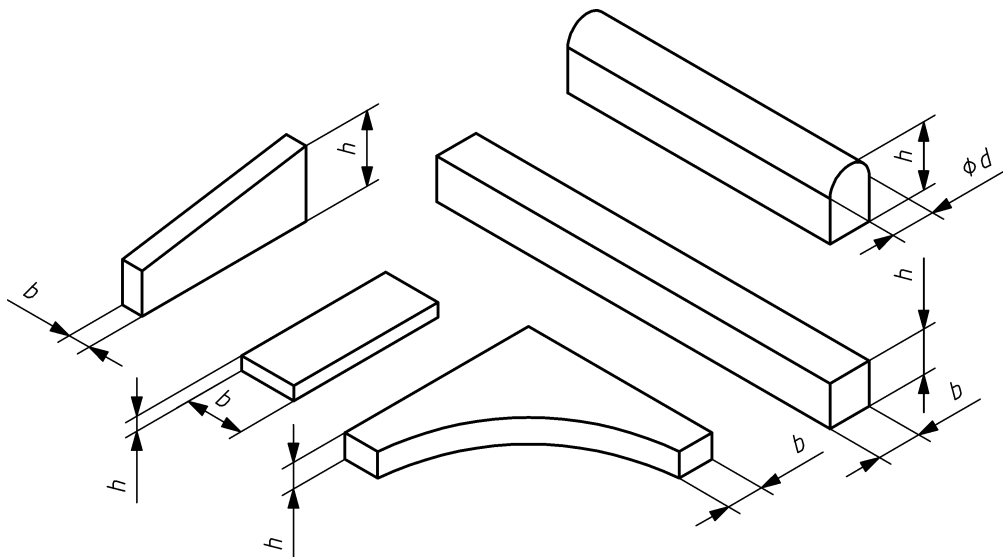

Figure 5 — Examples for ledges

Table 4 — Dimensions of ledges

Width b or diameter d mm	Height h mm
minimum 200	maximum 1 500

If there is an adjacent rolling surface it shall have a width of at least 1 200 mm.

5.2.4 Rail

The rail (see Figure 6) simulates a railing and enables e.g. gliding along or jumping over.

The distance between the lower edge of the rail and the rolling surface shall be at least 200 mm. The height of the rail shall not be greater than 1 000 mm.

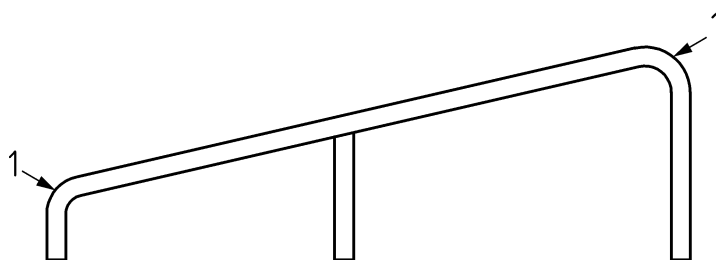
**Key**

1 outer radius or chamfer of 45°

Figure 6 — Example of a rail

If there is an adjacent rolling surface it shall have a width of at least 1 200 mm.

The ends of rails shall reach to the ground. The outside radius or chamfer of 45° shall be at least 20 mm.

Supports to the ground shall not protrude laterally over the entire length of the rail.

A rail shall withstand a horizontal transverse load of 750 N/m. This requirement is met when no damage or permanent deformation occurs when tested in accordance with Clause 6.

5.2.5 Jump ramp

Ramp incorporating a single transition or bank without any platform.

An example is shown in Figure 7. Dimensions of a jump ramp see Table 5.

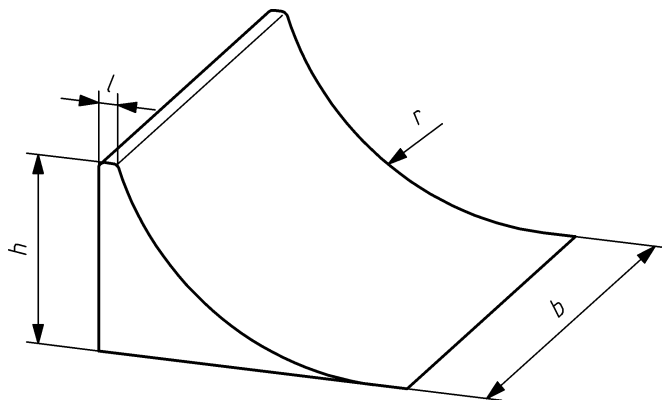

Figure 7 — Example of a jump ramp

Table 5 — Dimensions of a jump ramp

Height h mm	Width b mm	Length l^a of upper section mm	Radius r of transition mm	Angle of bank inclination
maximum 1 000	minimum 1 200	minimum 20 maximum 100	minimum 1 800	maximum 40°

^a This dimension can also be a diameter.

5.2.6 Platform bank

The platform bank is a bank provided with a platform. Where the platform bank has a height $h \leq 1\,000$ mm it can be provided with a table instead of a platform.

An example of a platform bank is shown in Figure 8. Dimensions of a platform bank see Table 6.

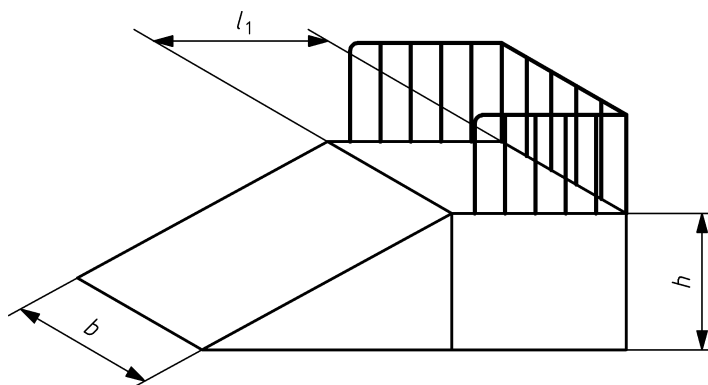

Figure 8 — Example of a platform bank

Table 6 — Dimensions of a platform bank

Height h mm	Width b mm	Depth l_1 mm
$\leq 1\,000$	minimum 1 200	minimum 1 200
$> 1\,000$ to 1 500	minimum 2 400	
$> 1\,500$ to 3 000	minimum 3 600	

A bank higher than 1 000 mm without a platform shall have a barrier.

5.2.7 Platform transition

The platform transition is a transition provided with a platform. Where the platform transition has a height $h \leq 1\,000$ mm it can be provided with a table instead of the platform.

An example of a platform transition is shown in Figure 9. Dimensions of a platform transition see Table 7.

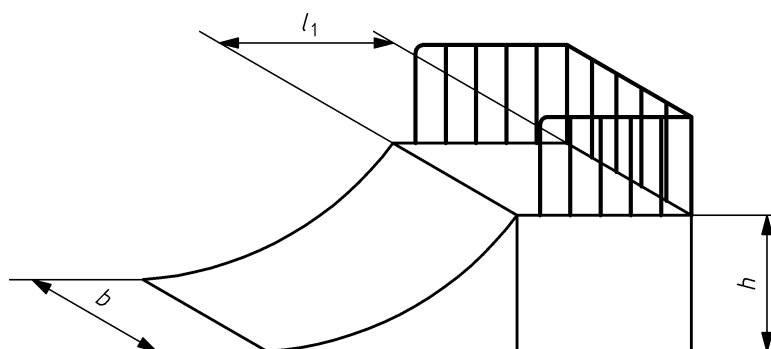

Figure 9 — Example of a platform transition

Table 7 — Dimensions of a platform transition

Height h mm	Width b mm	Depth l_1 mm	Radius r mm
$\leq 1\ 000$	minimum 1 200	minimum 1 200	minimum 1 800
$> 1\ 000$ to 1 500	minimum 2 400		minimum 1 800
$> 1\ 500$ to 3 000	minimum 3 600		minimum 1 800

If a platform transition is provided with a coping it has to meet the requirements specified in 5.1.2.6.

5.2.8 Spine ramp

Structure with two opposite transitions or banks forming a ridge.

An example of a spine ramp is given in Figure 10. Dimensions of a spine ramp see Table 8.

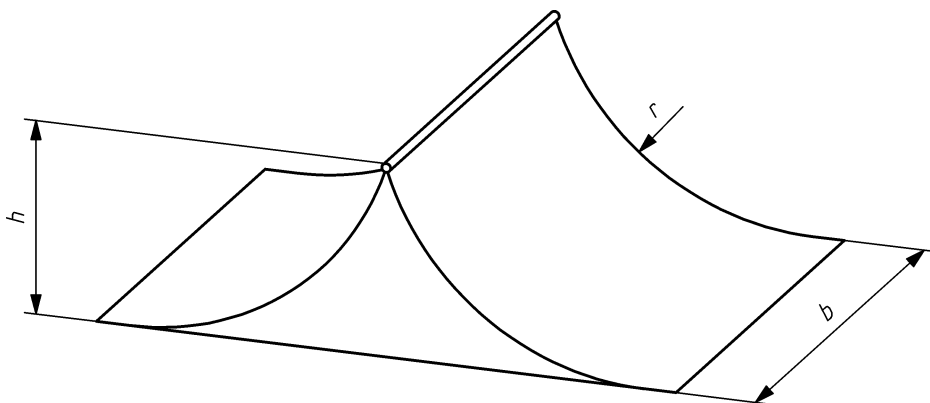

Figure 10 — Example of a spine ramp

Table 8 — Dimensions of a spine ramp

Height h mm	Width b mm	Radius r of transitions mm	Angle of bank inclination
$\leq 1\ 000$	minimum 1 200	minimum 1 800	maximum 40°
$> 1\ 000$ to 1 250	minimum 2 400		
$> 1\ 250$ to 1 500	minimum 3 600		

The ridge of the spine ramp shall have a minimum width of 40 mm and a maximum width of 140 mm. This requirement is not required for a spine ramp consisting of two banks.

If a spine ramp is provided with a coping it has to meet the requirements specified in 5.1.2.6.

5.2.9 Wall ramp

Structure with a bank or transition meeting a vertical rolling surface.

An example of a wall ramp is given in Figure 11. Dimensions of a wall ramp see Table 9.

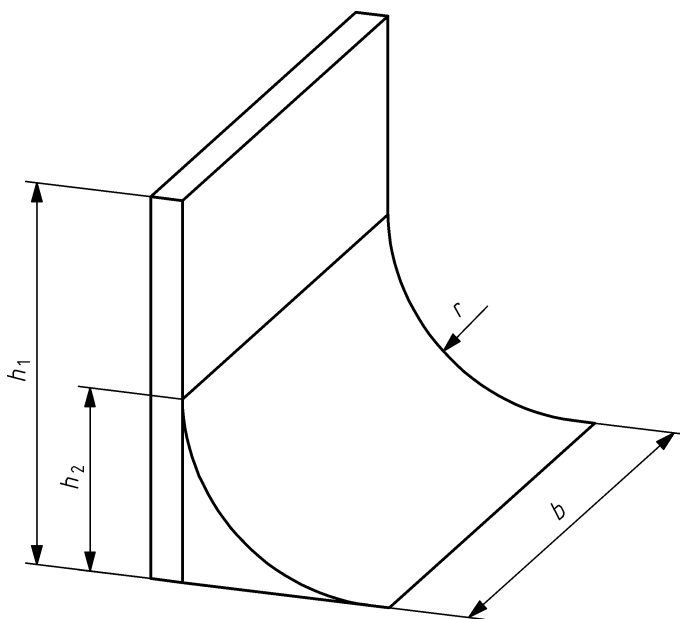

Figure 11 — Example of a wall ramp

Table 9 — Dimensions of a wall ramp

Structure	Radius r mm	Width b mm	Height h_1 mm	Height h_2 mm
Wall ramp with transition	minimum 1 000 maximum 2 000	minimum 2 400	minimum 2 000	$r \pm 5\%$
	$> 2\ 000$ to 3 000	minimum 3 600	$\geq r$	
Wall ramp with bank	—	minimum 2 400	minimum 1 500	maximum 1 500
		minimum 3 600		minimum 1 500 maximum 2 500

5.2.10 Pyramid bank

Structure in the shape of a truncated pyramid consisting of at least three quadrilateral connected rolling surfaces.

An example of a pyramid bank is shown in Figure 12.

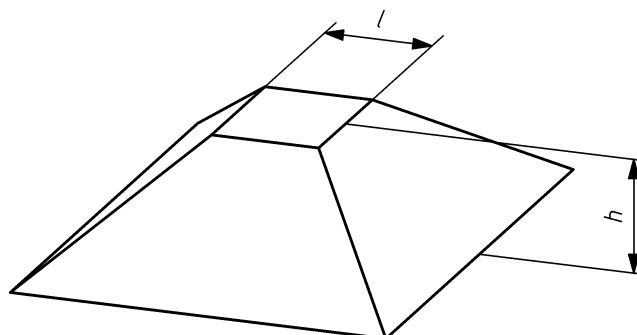

Figure 12 — Example of a pyramid bank

The height h shall not exceed 1 500 mm and the length l of the upper quadrilateral edge shall be at least 100 mm. Where the pyramid is fully sided with rolling surfaces there is no height limitation.

All surfaces of the pyramid bank shall be closed.

5.2.11 Stair

A stair consists of at least three steps. Dimensions of a stair see Table 10.

Table 10 — Dimensions of a stair

Height mm	Width mm	Depth of steps mm	Height of steps mm
$\leq 1\ 000$	minimum 1 200	minimum 250	maximum 350
$> 1\ 000$ to 1 500	minimum 2 400		

The edges of stairs shall be constructed as grinding surfaces in accordance with 5.1.2.4.

The vertical section of the steps shall be closed.

Stairs higher than 1 000 mm are not allowed to be installed under rails and curbs.

5.2.12 Pipe

A pipe (see Figure 13) is a structure consisting of two opposite transitions connected by a horizontal rolling surface. Dimensions of a pipe see Table 11.

The pipe is equipped with a platform each on both ends of the rolling surface.

The platforms shall only be accessible for the intended use over the rolling surface. It shall therefore be designed so that it does not induce anyone to climbing.

Platforms shall be equipped with a barrier in accordance with 5.1.2.5.

The pipe shall be fitted over its entire width with one coping at the upper end of the vert. The vert transition has to be vertical $\pm 2^\circ$.

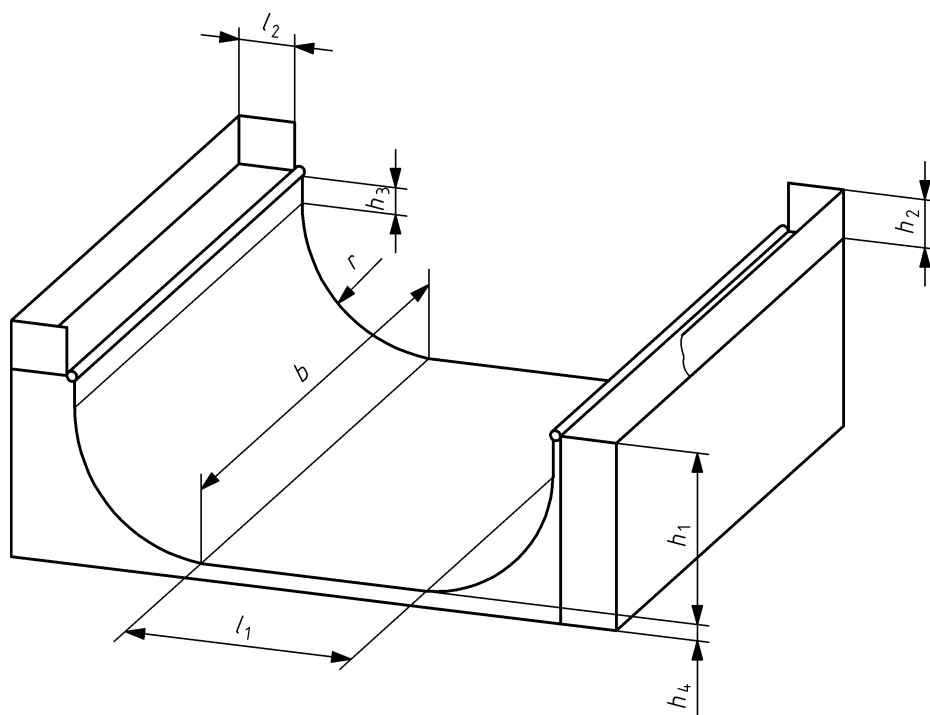
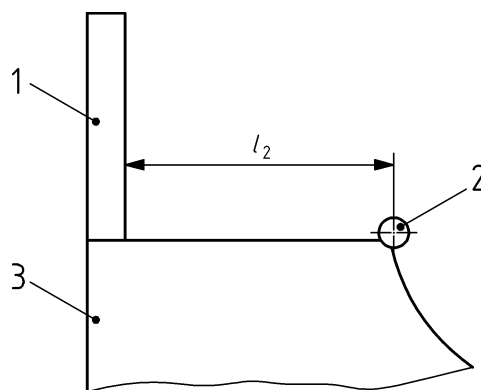

Figure 13 — Example of a pipe

Table 11 — Dimensions of a pipe

Description	h_1 mm	b mm	r mm	h_3 mm	h_2 mm	l_2 mm	l_1 mm	h_4 mm
Mini-Pipe	$\leq 1\ 250$	$\geq 2\ 400$	$\geq 1\ 800$ and $\geq h_1$	No vert allowed	$\geq 1\ 200$	$\geq 1\ 200$	$\geq r$	≤ 600
	$> 1\ 250$ to $2\ 000$	$\geq 3\ 600$						
	$\geq 2\ 000$ to $3\ 000$	$\geq 4\ 800$						
Half-Pipe	$\geq 2\ 500$ $\leq 4\ 200$	$\geq 6\ 000$	$\geq 2\ 400$ $\leq 3\ 600$	≤ 600	$\geq 1\ 200$			
	$\leq 4\ 200$ to $5\ 000$	$\geq 7\ 200$	$\leq 4\ 500$	maximum $1\ 000$				

**Key**

- 1 barrier
- 2 coping
- 3 structure

$$l_2 \geq 1\,200 \text{ mm}$$

Figure 14 — Depth of the platform

To refrain from indicating a safety zone pipes can be provided with a board according to 5.1.2.7.

If a pipe is provided with a board the minimum width b shall be at least 1 200 mm greater the width specified in Table 11. The board must meet the requirements specified in 5.1.2.7.

5.2.13 Fun box

A fun box (see Figure 15) is a structure with one or more tables which is accessible from at least two opposite sides. Dimensions of a fun boxes table(s) according to Table 12.

Where the fun-box is fully sided with rolling surfaces there is no height limitation.

When a rail is installed on a fun box which is accessible from at least three sides, it shall project into the table not more than 300 mm (l_1), except where the space between the rail and the riding surface is closed. The distance between the ends of the rail and the opposite table edge shall be at least 1 200 mm (l_2).

Where several rails, curbs or ledges are installed side by side on the rolling surface, the distance between these structures shall be at least 1 500 mm (l_3).

Any vertical surfaces of open corners shall be closed.

Closed corners shall comply with the requirements in accordance with 5.1.2.3.

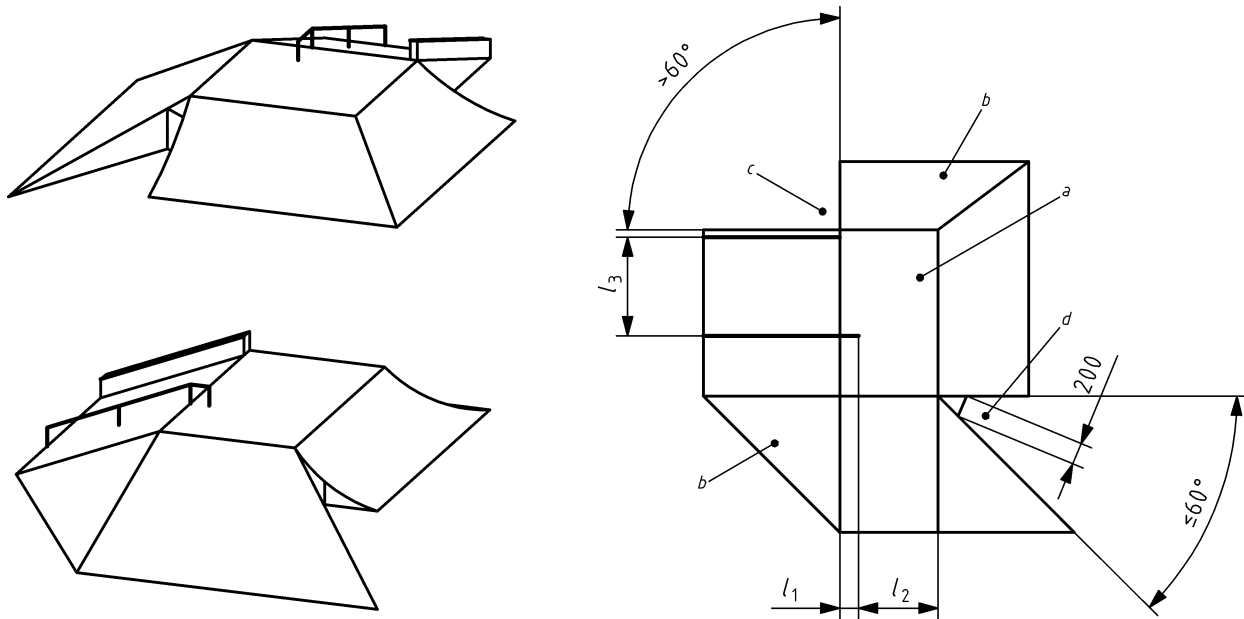

Key

- a table
- b closed corner
- c open corner at angle $> 60^\circ$
- d partly closed corner at angle $\leq 60^\circ$

Figure 15 — Example of a fun box

Table 12 — Dimensions of the table of a fun box

Height mm	Table edge mm
maximum 1 000	minimum 1 200
maximum 1 250	minimum 1 800
maximum 1 500	minimum 2 400 ^a
^a If the corners are fully closed this value can be reduced to 1 200 mm.	

Where the angle of a corner of the fun box is less than 60° , the corner shall be closed up to a width of at least 200 mm (see Figure 15).

5.3 Safety zones

5.3.1 General

Each structure shall be provided with a safety zone around the structure.

The safety zones according to 5.3.2.2 to 5.3.2.4 apply to self-supporting structures and may intersect one another. In the case of such intersections at least the greatest safety zone of the relevant individual structure shall be observed.

Safety zones shall be free from any obstacles and are not intended as a viewing area for spectators. The surface of the safety zones shall be of a bound uniform material. Loose material, e. g. sand, shall not be used.

There is no need for a safety zone in the adjacent area behind a structure provided with a platform or behind a wall ramp.

5.3.2 Special requirements for safety zones

5.3.2.1 General

The dimensions given in 5.3.2.2 to 5.3.2.4 apply to the floor space of the safety zone. They are minimum requirements and consideration shall be given to increase the distances to allow additional space for a run-up zone and a run-out zone.

5.3.2.2 Requirements

The safety zone shall be at least 2 000 mm around the structure measured from each point of the structure for curb, ledge, rail, platform bank, platform transition, spine ramp, pyramid bank, stair, wall ramp pipe and fun box.

5.3.2.3 Dimensions for jump ramps

See Figure 16.

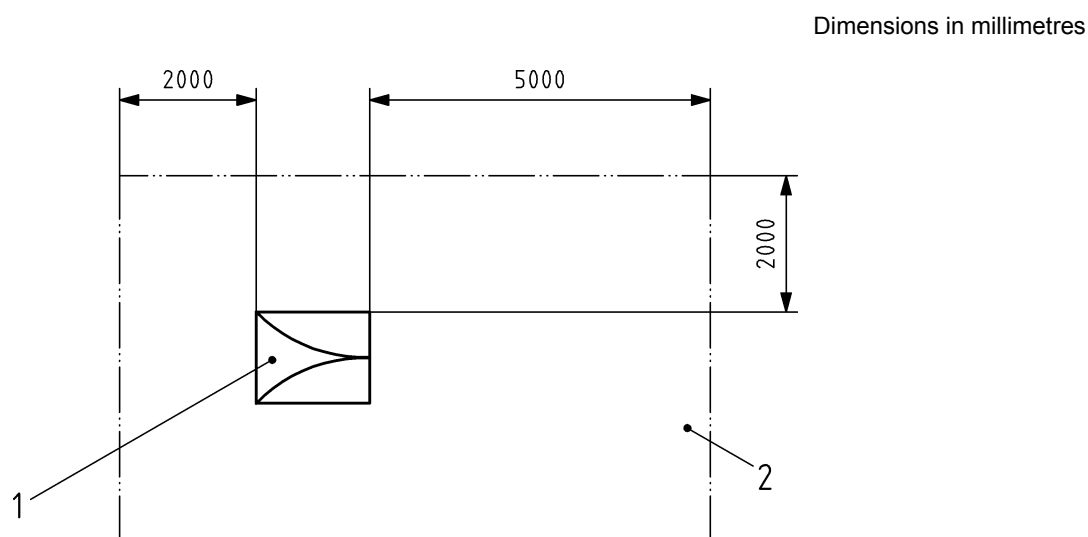

Key

- 1 jump ramp
- 2 safety zone

Figure 16 — Safety zone of a jump ramp

6 Testing

Requirements shall be tested either in accordance with the standards defined in this standard or e.g. by measurements or visual inspection.

Testing of barriers (see 5.1.2.5), boards (see 5.1.2.7) and rails (see 5.2.4) is carried out at several unfavourable points at a distance of 1 000 mm to each other and in an unfavourable direction. The test force is initiated acting two-dimensionally over a length of 80 mm.

All riding surfaces apply the test force in accordance with 5.1.2.1 equally over the total surface.

Apply the horizontal force in accordance with 5.1.2.1 in the middle of the highest part of the riding surface. See also Figure 1.

7 Marking

The marking on the structure shall be legible and durable indicating at least the following:

- a) name and address of the manufacturer or of his or her approved representative;
- b) structure identification;
- c) year of manufacture;
- d) number and date of this standard, EN 14974:2006.

8 Information supplied by the manufacturer

8.1 General

The manufacturer/supplier shall provide instructions in the appropriate language(s) of the country in which the equipment is to be installed and used. The instructions shall comply with the following:

- a) instructions shall be printed legibly and in a simple form;
- b) illustrations shall be used wherever possible; and
- c) instructions, which shall include at least the following information:
 - 1) details of the installation, operation, inspection and maintenance of the equipment;
 - 2) clause or note drawing the operator's attention to the need to increase inspection/maintenance if the equipment is subject to heavy use.

8.2 Installation

The manufacturer/supplier shall supply information for the installation of the structure including at least the following:

- a) dimensions of the structure including safety zone;
- b) ground requirements;
- c) conformity with this standard;
- d) instructions how to erect the structure properly;
- e) list of special tools required;
- f) details of the required foundations and anchorings, where necessary.

The instructions for installation shall be complemented by clear and detailed drawings (e.g. explosion drawing) and/or pictorial representations.

8.3 Inspection and maintenance

The inspection and maintenance of the structure shall preserve and ensure the intended safety of the equipment.

Each structure shall be supplied by the manufacturer with instructions for maintenance including at least the following:

- a) information on construction details in need of care (e.g. cleaning of water drops, tightening of screw connections);
- b) information on repair details (e.g. information on materials);
- c) information on special materials requiring special disposal;
- d) information on inspection and maintenance intervals.

Maintenance includes all necessary measures for maintaining the technical safety requirements. It does not only relate to the structure itself but also to the particular safety zones.

NOTE The inspection and maintenance intervals defined by the manufacturer can only be related to average experience values.

9 Information for users

Clear and visible sign(s) shall be provided to indicate the following:

- a) facility (facilities) for users of in-line skates, roller skates, skateboards and BMX cycles;
- b) use of appropriate protective equipment (e.g. helmet, knee pads, elbow pads, etc.) is recommended;
- c) administrator's identification.

BSI — British Standards Institution

BSI is the independent national body responsible for preparing British Standards. It presents the UK view on standards in Europe and at the international level. It is incorporated by Royal Charter.

Revisions

British Standards are updated by amendment or revision. Users of British Standards should make sure that they possess the latest amendments or editions.

It is the constant aim of BSI to improve the quality of our products and services. We would be grateful if anyone finding an inaccuracy or ambiguity while using this British Standard would inform the Secretary of the technical committee responsible, the identity of which can be found on the inside front cover.
Tel: +44 (0)20 8996 9000. Fax: +44 (0)20 8996 7400.

BSI offers members an individual updating service called PLUS which ensures that subscribers automatically receive the latest editions of standards.

Buying standards

Orders for all BSI, international and foreign standards publications should be addressed to Customer Services. Tel: +44 (0)20 8996 9001.
Fax: +44 (0)20 8996 7001. Email: orders@bsi-global.com. Standards are also available from the BSI website at <http://www.bsi-global.com>.

In response to orders for international standards, it is BSI policy to supply the BSI implementation of those that have been published as British Standards, unless otherwise requested.

Information on standards

BSI provides a wide range of information on national, European and international standards through its Library and its Technical Help to Exporters Service. Various BSI electronic information services are also available which give details on all its products and services. Contact the Information Centre.
Tel: +44 (0)20 8996 7111. Fax: +44 (0)20 8996 7048. Email: info@bsi-global.com.

Subscribing members of BSI are kept up to date with standards developments and receive substantial discounts on the purchase price of standards. For details of these and other benefits contact Membership Administration.
Tel: +44 (0)20 8996 7002. Fax: +44 (0)20 8996 7001.
Email: membership@bsi-global.com.

Information regarding online access to British Standards via British Standards Online can be found at <http://www.bsi-global.com/bsonline>.

Further information about BSI is available on the BSI website at <http://www.bsi-global.com>.

Copyright

Copyright subsists in all BSI publications. BSI also holds the copyright, in the UK, of the publications of the international standardization bodies. Except as permitted under the Copyright, Designs and Patents Act 1988 no extract may be reproduced, stored in a retrieval system or transmitted in any form or by any means – electronic, photocopying, recording or otherwise – without prior written permission from BSI.

This does not preclude the free use, in the course of implementing the standard, of necessary details such as symbols, and size, type or grade designations. If these details are to be used for any other purpose than implementation then the prior written permission of BSI must be obtained.

Details and advice can be obtained from the Copyright & Licensing Manager.
Tel: +44 (0)20 8996 7070. Fax: +44 (0)20 8996 7553.
Email: copyright@bsi-global.com.