

# Thermal insulation and light weight fill products for civil engineering applications — Factory made products of expanded polystyrene (EPS) — Specification

The European Standard EN 14933:2007 has the status of a  
British Standard

ICS 83.100; 91.120.10; 93.010

## National foreword

This British Standard is the UK implementation of EN 14933:2007.

The UK participation in its preparation was entrusted to Technical Committee PRI/72, Rigid cellular materials.

A list of organizations represented on this committee can be obtained on request to its secretary.

This publication does not purport to include all the necessary provisions of a contract. Users are responsible for its correct application.

**Compliance with a British Standard cannot confer immunity from legal obligations.**

This British Standard was published under the authority of the Standards Policy and Strategy Committee on 31 October 2007

© BSI 2007

ISBN 978 0 580 54387 6

### Amendments issued since publication

Amd. No.	Date	Comments

EUROPEAN STANDARD

**EN 14933**

NORME EUROPÉENNE

EUROPÄISCHE NORM

September 2007

ICS 83.100; 93.010

English Version

**Thermal insulation and light weight fill products for civil  
engineering applications - Factory made products of expanded  
polystyrene (EPS) - Specification**

Produits isolants thermiques et de remblayage pour les  
applications de génie civil - Produits manufacturés en  
Polystyrène expansé (EPS) - Spécifications

Wärmedämmung und leichte Füllprodukte für  
Anwendungen im Tiefbau - Werkmäßig hergestellte  
Produkte aus expandiertem Polystyrol (EPS) - Spezifikation

This European Standard was approved by CEN on 13 July 2007.

CEN members are bound to comply with the CEN/CENELEC Internal Regulations which stipulate the conditions for giving this European Standard the status of a national standard without any alteration. Up-to-date lists and bibliographical references concerning such national standards may be obtained on application to the CEN Management Centre or to any CEN member.

This European Standard exists in three official versions (English, French, German). A version in any other language made by translation under the responsibility of a CEN member into its own language and notified to the CEN Management Centre has the same status as the official versions.

CEN members are the national standards bodies of Austria, Belgium, Bulgaria, Cyprus, Czech Republic, Denmark, Estonia, Finland, France, Germany, Greece, Hungary, Iceland, Ireland, Italy, Latvia, Lithuania, Luxembourg, Malta, Netherlands, Norway, Poland, Portugal, Romania, Slovakia, Slovenia, Spain, Sweden, Switzerland and United Kingdom.



EUROPEAN COMMITTEE FOR STANDARDIZATION  
COMITÉ EUROPÉEN DE NORMALISATION  
EUROPÄISCHES KOMITEE FÜR NORMUNG

**Management Centre: rue de Stassart, 36 B-1050 Brussels**

# Contents

Page

Foreword.....	5
<b>1</b> <b>Scope</b> .....	<b>6</b>
<b>2</b> <b>Normative references</b> .....	<b>6</b>
<b>3</b> <b>Terms, definitions, symbols, units and abbreviated terms</b> .....	<b>7</b>
3.1 <b>Terms and definitions</b> .....	7
3.2 <b>Symbols, units and abbreviated terms</b> .....	8
<b>4</b> <b>Requirements</b> .....	<b>10</b>
4.1 <b>General</b> .....	10
4.2 <b>For all applications</b> .....	11
4.3 <b>For specific applications</b> .....	13
<b>5</b> <b>Test methods</b> .....	<b>20</b>
5.1 <b>Sampling</b> .....	20
5.2 <b>Conditioning</b> .....	20
5.3 <b>Testing</b> .....	20
<b>6</b> <b>Designation code</b> .....	<b>22</b>
<b>7</b> <b>Evaluation of conformity</b> .....	<b>23</b>
<b>8</b> <b>Marking and labelling</b> .....	<b>23</b>
<b>Annex A (normative) Determination of the declared values of thermal resistance and thermal conductivity</b> .....	<b>25</b>
A.1 <b>Introduction</b> .....	25
A.2 <b>Input data</b> .....	25
A.3 <b>Declared values</b> .....	25
A.3.1 <b>General</b> .....	25
A.3.2 <b>Case where thermal resistance and thermal conductivity are declared</b> .....	25
A.3.3 <b>Case where thermal resistance alone is declared</b> .....	26
<b>Annex B (normative) Factory production control</b> .....	<b>27</b>
B.1 <b>Testing frequencies</b> .....	27
B.2 <b>Indirect testing</b> .....	31
B.2.1 <b>General</b> .....	31
B.2.2 <b>Compressive stress at 10 % deformation</b> .....	31
B.2.3 <b>Thermal conductivity</b> .....	32
<b>Annex C (normative) Product classification</b> .....	<b>33</b>
<b>Annex D (normative) Determination of behaviour under cyclic square-wave load</b> .....	<b>34</b>
D.1 <b>Scope</b> .....	34
D.2 <b>Definitions</b> .....	34
D.3 <b>Principle</b> .....	35
D.4 <b>Testing equipment</b> .....	35
D.4.1 <b>Cutting tool</b> .....	35
D.4.2 <b>Length measuring equipment</b> .....	35
D.4.3 <b>Steel plate</b> .....	35
D.4.4 <b>Measuring gauges</b> .....	35
D.4.5 <b>Apparatus</b> .....	35
D.5 <b>Test specimens</b> .....	36
D.5.1 <b>Dimensions of test specimens</b> .....	36
D.5.2 <b>Number of test specimens</b> .....	36
D.5.3 <b>Conditioning of test specimens</b> .....	36

<b>D.6</b>	<b>Procedure</b> .....	<b>36</b>
<b>D.6.1</b>	<b>Test conditions</b> .....	<b>36</b>
<b>D.6.2</b>	<b>Test procedure</b> .....	<b>36</b>
<b>D.7</b>	<b>Calculation and expression of results</b> .....	<b>38</b>
<b>D.8</b>	<b>Accuracy of measurement</b> .....	<b>39</b>
<b>D.9</b>	<b>Test report</b> .....	<b>39</b>
<b>Annex E</b>	<b>(informative) Additional properties</b> .....	<b>40</b>
<b>E.1</b>	<b>General</b> .....	<b>40</b>
<b>E.2</b>	<b>Compressive modulus of elasticity</b> .....	<b>40</b>
<b>E.3</b>	<b>Determination of shear strength</b> .....	<b>40</b>
<b>E.4</b>	<b>Long-term compressive behaviour</b> .....	<b>41</b>
<b>E.5</b>	<b>Water vapour diffusion resistance factor</b> .....	<b>42</b>
<b>E.6</b>	<b>Additional information</b> .....	<b>42</b>
<b>Annex ZA</b>	<b>(informative) Relationship between this European Standard and the Essential Requirements of EU Directive 89/106/EEC, EU Construction Products Directive</b> .....	<b>43</b>
<b>ZA.1</b>	<b>Scope and relevant characteristics</b> .....	<b>43</b>
<b>ZA.2</b>	<b>Procedures for attestation of conformity of expanded polystyrene products</b> .....	<b>45</b>
<b>ZA.2.1</b>	<b>Systems of attestation of conformity</b> .....	<b>45</b>
<b>ZA.2.2</b>	<b>EC certificate and declaration of conformity</b> .....	<b>48</b>
<b>ZA.3</b>	<b>CE Marking and labelling</b> .....	<b>50</b>
<b>Bibliography</b>	.....	<b>52</b>

## Figures

Figure B.1	— Relationship between compressive stress at 10 % deformation and apparent density for indirect testing; $1 - \alpha = 0,90$ ; $n = 495$ .....	<b>31</b>
Figure B.2	— Relationship between declared thermal conductivity (at 50 mm reference thickness) and apparent density; $1 - \alpha = 0,90$ ; $n = 3\ 873$ .....	<b>32</b>
Figure D.1	— Required load cycle during the fatigue test .....	<b>36</b>
Figure D.2	— Dimensions of the test specimen .....	<b>37</b>
Figure D.3	— Test set-up .....	<b>38</b>
Figure ZA.1	— Example CE marking information .....	<b>51</b>

## Tables

Table 1	— Classes of dimensional tolerances .....	<b>12</b>
Table 2	— Levels for compressive stress at 10 % deformation .....	<b>13</b>
Table 3	— Levels of dimensional stability under specified temperature and humidity conditions .....	<b>14</b>
Table 4	— Levels of deformation under specified compressive load and temperature conditions .....	<b>14</b>
Table 5	— Levels for compressive stress at 2 % deformation .....	<b>15</b>
Table 6	— Levels for compressive stress at 5 % deformation .....	<b>15</b>
Table 7	— Levels of bending strength .....	<b>17</b>

Table 8 — Levels for long term water absorption by total immersion .....	18
Table 9 — Levels for long term water absorption by diffusion.....	19
Table 10 — Levels for freeze-thaw resistance .....	19
Table 11 — Test methods, test specimens and conditions .....	20
Table A.1 — Values for $k$ for one sided 90 % tolerance interval with a confidence level of 90 %.....	26
Table B.1 — Minimum product testing frequencies.....	27
Table B.2 — Minimum product testing frequencies for the reaction to fire characteristics .....	29
Table C.1 — Classification of EPS products .....	33
Table E.1 — Correlation between bending strength and shear strength .....	40
Table E.2 — Test methods, test specimens, conditions and minimum testing frequencies .....	41
Table E.3 — Tabulated values of water vapour diffusion resistance index and water vapour permeability .....	42
Table ZA.1 — Relevant clauses .....	44
Table ZA.2 — System(s) of attestation of conformity.....	46
Table ZA.2.1 — Assignment of evaluation of conformity tasks for products under system 1 .....	47
Table ZA.2.2 — Assignment of evaluation of conformity tasks for products under system 3 and 3 (with 4 for RfF).....	48

标准分享网 www.bzfxw.com

## Foreword

This document (EN 14933:2007) has been prepared by Technical Committee CEN/TC 88 “Thermal insulating materials and products”, the secretariat of which is held by DIN.

This European Standard shall be given the status of a national standard, either by publication of an identical text or by endorsement, at the latest by March 2008, and conflicting national standards shall be withdrawn at the latest by March 2008.

Attention is drawn to the possibility that some of the elements of this document may be the subject of patent rights. CEN [and/or CENELEC] shall not be held responsible for identifying any or all such patent rights.

This document has been prepared under a mandate given to CEN by the European Commission and the European Free Trade Association, and supports essential requirements of EU Directive(s).

For relationship with EU Directive(s), see informative Annex ZA, which is an integral part of this document.

This European Standard is one of a series of standards for products used for insulation in buildings, insulation of building equipment and industrial installations and in civil engineering applications.

According to the CEN/CENELEC Internal Regulations, the national standards organizations of the following countries are bound to implement this European Standard: Austria, Belgium, Bulgaria, Cyprus, Czech Republic, Denmark, Estonia, Finland, France, Germany, Greece, Hungary, Iceland, Ireland, Italy, Latvia, Lithuania, Luxembourg, Malta, Netherlands, Norway, Poland, Portugal, Romania, Slovakia, Slovenia, Spain, Sweden, Switzerland and the United Kingdom.

标准分享网 www.bzxz.net

## 1 Scope

This European Standard specifies the requirements for factory made products of expanded polystyrene which are used for frost insulation of roads, railways, trafficked areas, light weight fill for reduction of horizontal and vertical earth pressure and other civil engineering applications.

The products are manufactured in the form of boards or blocks. The standard also covers specially cut shaped boards or blocks.

The standard describes product characteristics and includes procedures for testing, evaluation of conformity, marking and labelling.

The standard does not specify the required class or level of a given property to be achieved by a product to demonstrate fitness for purpose in a particular application. The classes and levels required for a given application are to be found in regulations or non-conflicting standards.

For applications where thermal resistance is required, products with a declared thermal resistance lower than 0,25 m<sup>2</sup>·K/W or a declared thermal conductivity greater than 0,060 W/(m·K) are not covered by this standard. This standard does not cover in situ insulation products and products intended to be used for the insulation of buildings, of building equipment and industrial installations or products intended for acoustic insulation.

## 2 Normative references

The following referenced documents are indispensable for the application of this document. For dated references, only the edition cited applies. For undated references, the latest edition of the referenced document (including any amendments) applies.

EN 822, *Thermal insulating products for building applications — Determination of length and width*

EN 823, *Thermal insulating products for building applications — Determination of thickness*

EN 824, *Thermal insulating products for building applications — Determination of squareness*

EN 825, *Thermal insulating products for building applications — Determination of flatness*

EN 826, *Thermal insulating products for building applications — Determination of compression behaviour*

EN 1602, *Thermal insulating products for building applications — Determination of the apparent density*

EN 1604, *Thermal insulating products for building applications — Determination of dimensional stability under specified temperature and humidity conditions*

EN 1605, *Thermal insulating products for building applications — Determination of deformation under specified compressive load and temperature conditions*

EN 1606, *Thermal insulating products for building applications — Determination of compressive creep*

EN 12085, *Thermal insulating products for building applications - Determination of linear dimensions of test specimens*

EN 12086, *Thermal insulating products for building applications — Determination of water vapour transmission properties*



EN 12087, *Thermal insulating products for building applications — Determination of long-term water absorption by immersion*

EN 12088, *Thermal insulating products for building applications — Determination of long-term water absorption by diffusion*

EN 12089, *Thermal insulating products for building applications — Determination of bending behaviour*

EN 12091, *Thermal insulating products for building applications — Determination of freeze-thaw resistance*

EN 12667, *Thermal performance of building materials and products — Determination of thermal resistance by means of guarded hot plate and heat flow meter methods — Products of high and medium thermal resistance*

EN 12939, *Thermal performance of building materials and products — Determination of thermal resistance by means of guarded hot plate and heat flow meter methods — Thick products of high and medium thermal resistance*

EN 13172:2001, *Thermal insulating products — Evaluation of conformity*

EN 13501-1, *Fire classification of construction products and building elements — Part 1: Classification using test data from reaction to fire tests*

EN 13793, *Thermal insulating products for building applications — Determination of behaviour under cyclic loading*

EN 13823, *Reaction to fire tests for building products — Building products excluding floorings exposed to thermal attack by a single burning item*

EN ISO 1182, *Reaction to fire tests for building products — Non combustibility test (ISO 1182:2002)*

EN ISO 1716, *Reaction to fire tests for building products — Determination of the heat of combustion (ISO 1716:2002)*

EN ISO 9229:2007, *Thermal insulation — Vocabulary (ISO 9229:2007)*

EN ISO 11925-2, *Reaction to fire tests — Ignitability of building products subjected to direct impingement of flame — Part 2: Single-flame source test (ISO 11925-2:2002)*

ISO 12491, *Statistical methods for quality control of building materials and components*

### **3 Terms, definitions, symbols, units and abbreviated terms**

#### **3.1 Terms and definitions**

For the purposes of this document, the following terms and definitions apply.

##### **3.1.1 Terms and definitions as given in EN ISO 9229:2007**

###### **3.1.1.1**

###### **expanded polystyrene (EPS)**

rigid cellular plastic material, manufactured by moulding beads of expandable polystyrene or one of its copolymers, with an air filled closed cellular structure

3.1.1.2

**expanded polystyrene block**

rigid insulation product or material generally of rectangular cross section and with a thickness not significantly smaller than the width. Blocks are supplied trimmed or untrimmed

3.1.1.3

**expanded polystyrene board**

rigid insulation product (cut, moulded, or continuously foamed) of rectangular shape and cross section in which the thickness is significantly smaller than the other dimensions. Boards may be of uniform thickness or tapered. The board edges may be of various sorts (e.g., square, half lapped, tongue and groove)

3.1.1.4

**preformed ware**

insulation shapes formed by cutting or grinding from blocks or boards or by shape moulding

3.1.2 Additional definitions

3.1.2.1

**level**

given value which is the upper or lower limit of a requirement. The level is given by the declared value of the characteristic concerned

3.1.2.2

**class**

combination of two levels of the same property between which the performance shall fall

3.2 Symbols, units and abbreviated terms

Symbols used in this standard:

$1 - \alpha$	is the prediction interval	—
$b$	is the width	mm
$d$	is the thickness	mm
$\delta$	is the water vapour permeability	mg/(m·h·Pa)
$D_i$	is the relative compression after $i$ number of cycles	%
$D_N$	is the nominal thickness of a product	m
$d_s$	is the thickness of the test specimen	m
$\Delta \varepsilon_b$	is the relative change in width	%
$\Delta \varepsilon_d$	is the relative change in thickness	%
$\Delta \varepsilon_l$	is the relative change in length	%
$\varepsilon_1$	is the deformation after step A according to EN 1605	%
$\varepsilon_2$	is the deformation after step B according to EN 1605	%
$\varepsilon_{ct}$	is the compressive creep	%
$\varepsilon_t$	is the total relative thickness reduction	%
$\varepsilon_{I,max}$	is the relative maximum deformation	%
$k$	is a factor related to the number of test results available	—

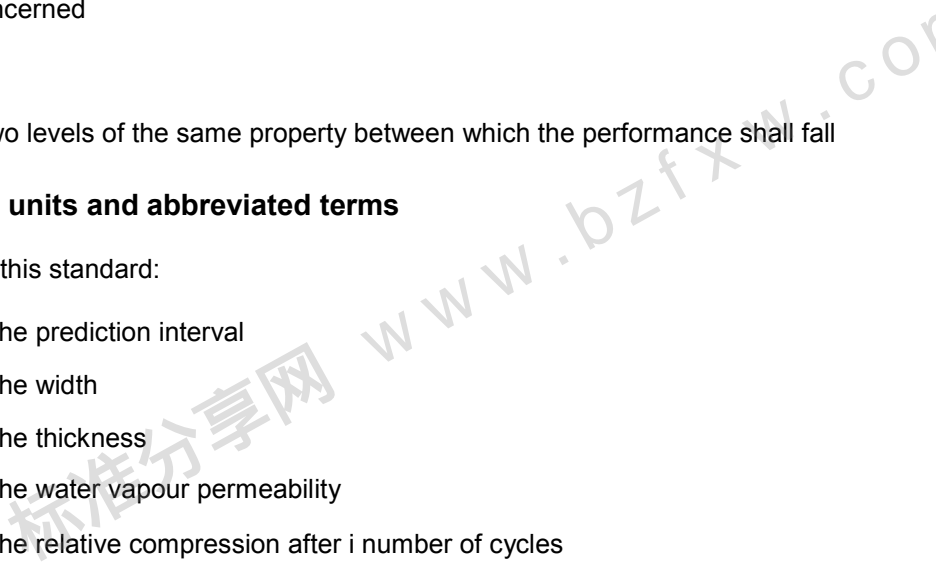

$l$	is the length	mm
$L$	is the thickness effect parameter	—
$\lambda_{90,90}$	is the 90 % fractile with a confidence level of 90 % for the thermal conductivity	W/(m·K)
$\lambda_D$	is the declared value of thermal conductivity	W/(m·K)
$\lambda_i$	is one test result of thermal conductivity	W/(m·K)
$\lambda'_i$	is one test result of thermal conductivity for which the thickness effect is not negligible	W/(m·K)
$\lambda_{\text{mean}}$	is the mean thermal conductivity	W/(m·K)
$\lambda_{\text{pred}}$	is the thermal conductivity with a prediction interval of 90 %	W/(m·K)
$\mu$	is the water vapour diffusion resistance factor	—
$n$	is the number of test results	—
$\rho_a$	is the apparent density	kg/m <sup>3</sup>
$R_{90/90}$	is the 90 % fractile with a confidence level of 90 % for the thermal resistance	m <sup>2</sup> ·K/W
$R_D$	is the declared thermal resistance	m <sup>2</sup> ·K/W
$R_i$	is one test result of thermal resistance	m <sup>2</sup> ·K/W
$R'_i$	is one test result of thermal resistance for which the thickness effect is not negligible	m <sup>2</sup> ·K/W
$R_{\text{mean}}$	is the mean thermal resistance	m <sup>2</sup> ·K/W
$s_R$	is the estimate of the standard deviation of the thermal resistance	m <sup>2</sup> ·K/W
$s_\lambda$	is the estimate of the standard deviation of the thermal conductivity	W/(m·K)
$S_b$	is the deviation from squareness	mm/m
$S_{\text{max}}$	is the deviation from flatness	mm
$\sigma_{10}$	is the compressive stress at 10 % deformation	kPa
$\sigma_{10, \text{mean}}$	is the mean compressive stress at 10 % deformation	kPa
$\sigma_{10, \text{pred}}$	is the predicted compressive stress at 10 % deformation with a prediction interval of 90 %	kPa
$\sigma_5$	is the compressive stress at 5 % deformation	kPa
$\sigma_2$	is the compressive stress at 2 % deformation	kPa
$\sigma_b$	is the bending strength	kPa
$\sigma_c$	is the compressive stress to determine $\varepsilon_t$	kPa
$\sigma_c$	is the declared compressive stress	kPa
$\tau$	is the shear strength	kPa
$W_{\text{dV}}$	is the water absorption by diffusion	% by volume

$W_{it}$	is the long-term water absorption by total immersion	% by volume
$W_v$	is water absorption by freeze-thaw after water absorption by diffusion	% by volume
$Z$	is the water vapour resistance	$m^2 \cdot h \cdot Pa/mg$
BS	is the symbol of the declared level for bending strength	
CC( $i_1, i_2/y$ ) $\sigma$	is the symbol of the declared level for compressive creep	
CLR( $i, z$ ) $\sigma_i$	is the symbol of the declared level for resistance to cyclic compressive loading with sinus load application	
CLRT( $i, z$ ) $\sigma_i$	is the symbol of the declared level for resistance to cyclic compressive loading with square wave load application	
CS (10)	is the symbol of the declared level for compressive stress at 10 % deformation	
CS (5)	is the symbol of the declared level for compressive stress at 5 % deformation	
CS (2)	is the symbol of the declared level for compressive stress at 2 % deformation	
DLT(i)5	is the symbol of the declared level for dimensional stability under load and temperature at a specific set of conditions with a maximum of 5 % deformation	
DS(TH)	is the symbol of the declared value for dimensional stability under specified temperature and humidity	
FTC	is the symbol of the declared level for freeze thaw resistance	
L	is the symbol of the declared class for length tolerances	
P	is the symbol of the declared class for flatness tolerance	
S	is the symbol of the declared class for squareness tolerance	
T	is the symbol of the declared class for thickness tolerance	
W	is the symbol of the declared class for width tolerance	
WD(V)	is the symbol of the declared level for water absorption by diffusion	
WL(T)	is the symbol of the declared level for water absorption by total immersion	
Z	is the symbol of the declared water vapour resistance value	

Abbreviated terms used in this standard:

**EPS** is expanded polystyrene

## 4 Requirements

### 4.1 General

Product properties shall be assessed in accordance with Clause 5. To comply with this standard, products shall meet the requirements of 4.2 and the requirements of 4.3, as appropriate.

NOTE Information on additional properties is given in Annex E.

One test result for a product property is the average of the measured values on the number of test specimens given in Table 11.

For mechanical properties no single measured value within the consecutive group used for obtaining the test result, shall be more than 10 % lower than of the limit value defining the level. For non mechanical properties a deviation from the limit value may be permitted and where appropriate these are expressed in the text.

## 4.2 For all applications

### 4.2.1 Length and width

Length,  $l$ , and width,  $b$ , shall be determined in accordance with EN 822. No test result shall deviate from the declared values by more than the tolerances given in Table 1 for the declared class.

### 4.2.2 Thickness

Thickness,  $d$ , shall be determined in accordance with EN 823. No test result shall deviate from the nominal thickness,  $d_N$ , by more than the tolerances given in Table 1, for the declared class.

### 4.2.3 Squareness

Squareness shall be determined in accordance with EN 824. The deviation from squareness on length and width,  $S_b$ , shall not exceed the tolerances given in Table 1, for the declared class.

### 4.2.4 Flatness

Flatness shall be determined in accordance with EN 825. The maximum deviation from flatness,  $S_{max}$ , shall not exceed the tolerances given in Table 1 for the declared class.

标准分享网 www.bzhfxw.com

Table 1 — Classes of dimensional tolerances

Property	Class	Tolerances
Length	L0	No requirement
	L1	$\pm 1,0 \%$ or $\pm 10 \text{ mm}^a$
	L2	$\pm 0,5 \%$ or $\pm 5 \text{ mm}^a$
	L3	$\pm 0,3 \%$ or $\pm 3 \text{ mm}^a$
Width	W0	No requirement
	W1	$\pm 0,5 \%$ or $\pm 5 \text{ mm}^a$
	W2	$\pm 0,3 \%$ or $\pm 3 \text{ mm}^a$
Thickness	T0	No requirement
	T1	$\pm 0,5 \%$ or $\pm 5 \text{ mm}^a$
	T2	$\pm 0,3 \%$ or $\pm 3 \text{ mm}^a$
	T3	$\pm 0,2 \%$ or $\pm 2 \text{ mm}^a$
Squareness	S0	No requirement
	S1	$\pm 5/1\,000 \text{ mm}$
	S2	$\pm 2/1\,000 \text{ mm}$
Flatness	P0	No requirement
	P1	$\pm 30 \text{ mm/m}$
	P2	$\pm 15 \text{ mm/m}$
	P3	$\pm 10 \text{ mm/m}$
	P4	$\pm 5 \text{ mm/m}$

<sup>a</sup> Whichever gives the greatest tolerance.

#### 4.2.5 Dimensional stability under specified temperature and humidity conditions

Dimensional stability under specified temperature and humidity conditions shall be determined in accordance with EN 1604. The test shall be carried out after storage for 48 h at  $(23 \pm 2)^\circ\text{C}$  temperature and  $(90 \pm 5) \%$  relative humidity. The relative changes in length,  $\Delta\varepsilon_l$ , width,  $\Delta\varepsilon_b$ , and thickness,  $\Delta\varepsilon_d$ , shall not exceed 1 %.

The test shall not be performed when the more severe test, described in 4.3.2.1, is used.

#### 4.2.6 Compressive stress at 10 % deformation

Compressive stress at 10 % deformation,  $\sigma_{10}$ , shall be determined in accordance with EN 826. No test result shall be lower than the values given in Table 2 for the declared level.

Table 2 — Levels for compressive stress at 10 % deformation

Level	Requirement kPa
CS(10)40	≥40
CS(10)50	≥50
CS(10)60	≥60
CS(10)70	≥70
CS(10)80	≥80
CS(10)90	≥90
CS(10)100	≥100
CS(10)120	≥120
CS(10)150	≥150
CS(10)200	≥200
CS(10)250	≥250
CS(10)300	≥300
CS(10)350	≥350
CS(10)400	≥400
CS(10)450	≥450
CS(10)500	≥500

#### 4.2.7 Bending strength

Bending strength,  $\sigma_b$ , shall be determined in accordance with EN 12089. For handling purposes, products shall have a minimum level of bending strength of 50 kPa.

#### 4.2.8 Reaction to fire

##### 4.2.8.1 Reaction to fire classification

Reaction to fire classification (Euroclasses) shall be determined in accordance with EN 13501-1.

##### 4.2.8.2 Continuous glowing combustion

Where subject to regulation, the continuous glowing combustion shall be declared. In the absence of a European test method which is under development, the existing relevant national test method applies.

### 4.3 For specific applications

#### 4.3.1 General

If there is no requirement for a property described in 4.3 for a product in use, than the property does not need to be determined and declared by the manufacturer.

### 4.3.2 Dimensional stability under specified conditions

#### 4.3.2.1 Dimensional stability under specified temperature and humidity conditions

Dimensional stability under specified temperature and humidity conditions shall be determined in accordance with EN 1604. The test shall be carried out for the conditions given in Table 3. The relative changes in length,  $\Delta\epsilon_l$ , width,  $\Delta\epsilon_b$ , and thickness,  $\Delta\epsilon_d$ , shall not exceed the values given in Table 3 for the declared level.

**Table 3 — Levels of dimensional stability under specified temperature and humidity conditions**

Class	Conditions	Requirement %
DS(70)1	48 h, 70 °C	1
DS(70)2	48 h, 70 °C	2
DS(70)3	48 h, 70 °C	3
DS(70, 90)1	48 h, 70 °C, 90 %	1

#### 4.3.2.2 Deformation under specified compressive load and temperature conditions

Deformation under specified compressive load and temperature conditions shall be determined in accordance with EN 1605. For each test condition the difference between the relative deformation,  $\epsilon_1$ , after step A and  $\epsilon_2$ , after step B as described in EN 1605 shall not exceed the values given in Table 4 for the declared level.

**Table 4 — Levels of deformation under specified compressive load and temperature conditions**

Level	Test conditions	Requirement %
DLT(1)5	load: 20 kPa temperature: (80 ± 1) °C time: (48 ± 1) h	≤5
DLT(2)5	load: 40 kPa temperature: (70 ± 1) °C time: (168 ± 1) h	≤5
DLT(3)5	load: 80 kPa temperature: (60 ± 1) °C time: (168 ± 1) h	≤5

### 4.3.3 Compressive stress at 2 % and/or 5 % deformation

The compressive stress at 2 % and/or 5 % deformation,  $\sigma_2$ , and/or  $\sigma_5$ , shall be determined in accordance with EN 826. No test result for either the compressive stress at 2 % and/or 5 % deformation,  $\sigma_2$ , and/or  $\sigma_5$ , shall be lower than the values given in Table 5 and Table 6 for the declared level.

NOTE Although EN 826 does not specify the calculation of the compressive stress at 2 % and 5 % deformation, the calculation should be done in the same way.



Table 5 — Levels for compressive stress at 2 % deformation

Level	Requirement kPa
CS(2)20	≥20
CS(2)30	≥30
CS(2)40	≥40
CS(2)50	≥50
CS(2)60	≥60
CS(2)70	≥70
CS(2)80	≥80
CS(2)90	≥90
CS(2)100	≥100
CS(2)120	≥120
CS(2)150	≥150
CS(2)200	≥200
CS(2)250	≥250
CS(2)300	≥300
CS(2)350	≥350

Table 6 — Levels for compressive stress at 5 % deformation

Level	Requirement kPa
CS(5)30	≥30
CS(5)40	≥40
CS(5)50	≥50
CS(5)60	≥60
CS(5)70	≥70
CS(5)80	≥80
CS(5)90	≥90
CS(5)100	≥100
CS(5)120	≥120

Table 6 (continued)

Level	Requirement kPa
CS(5)150	≥ 150
CS(5)200	≥ 200
CS(5)250	≥ 250
CS(5)300	≥ 300
CS(5)350	≥ 350
CS(5)400	≥ 400

#### 4.3.4 Point load

The effects of foot traffic shall be assessed by means of determination of compressive stress at 10 % deformation in accordance with EN 826, see 4.2.6

#### 4.3.5 Compressive creep

Compressive creep,  $\varepsilon_{ct}$ , and total thickness reduction,  $\varepsilon_t$ , shall be determined after at least one hundred twenty two days of testing at a declared compressive stress,  $\sigma_c$ , given in steps of at least 1 kPa, and the results extrapolated thirty times, corresponding to ten years, to obtain the declared levels in accordance with EN 1606. Compressive creep shall be declared in levels,  $i_2$  and the total thickness reduction shall be declared in levels,  $i_1$ , with steps of 0,5 % at the declared stress. No test result shall exceed the declared levels at the declared stress.

NOTE 1 For building applications a total thickness reduction,  $\varepsilon_t$ , of 2 % and an exploration time of 50 years are generally required.

NOTE 2 Examples for declaration of levels for compressive creep:

Level	Test time $t$ days	Extrapolation time years	Declared stress $\sigma_c$ kPa	Requirement %
CC( $i_1/i_2/10$ ) $\sigma_c$	122	10	$\sigma_c$	$\varepsilon_t \leq i_1$ and $\varepsilon_{ct} \leq i_2$
CC( $i_1/i_2/25$ ) $\sigma_c$	304	25	$\sigma_c$	$\varepsilon_t \leq i_1$ and $\varepsilon_{ct} \leq i_2$
CC( $i_1/i_2/50$ ) $\sigma_c$	608	50	$\sigma_c$	$\varepsilon_t \leq i_1$ and $\varepsilon_{ct} \leq i_2$

NOTE 3 Referring to the designation code CC( $i_1/i_2/y$ ) $\sigma_c$ , according to Clause 6, a declared level CC(2/1.5/50)100, for example, indicates a value not exceeding 1,5 % for compressive creep and 2 % for total thickness reduction after extrapolation at 50 years (i.e. 30 times six hundred eight days of testing) under a declared stress of 100 kPa.

#### 4.3.6 Resistance to cyclic compressive loading

##### 4.3.6.1 Resistance to cyclic compressive loading with square wave load application

The resistance to cycling compressive loading with square wave load application shall be determined in accordance with Annex D and shall be used specifically for railway applications. The relative compression,  $D_i$ , in % , shall be determined after a defined number of load cycles and the applied compressive stress,  $\sigma_i$ . The

relative compression,  $D_i$ , shall be declared as level, i. No test result shall exceed the declared level of,  $D_i$ , after  $2 \times 10^6$  load cycles at the declared stress.

NOTE For railway applications typically a relative compression,  $D_i$ , of 5 % after  $2 \times 10^6$  load cycles at a compressive stress or compressive strength of 100 to 300 kPa are generally required.

#### 4.3.6.2 Resistance to cyclic compressive loading with sinus load application

The resistance to cycling compressive loading with sinus load application shall be determined in accordance either with EN 13793. The relative deformation,  $\varepsilon_{i,max}$ , in percent shall be determined after a defined number of load cycles and the applied compressive stress,  $\sigma_i$ . The relative deformation,  $\varepsilon_{i,max}$ , shall be declared as level, i. No test result shall exceed the declared level at the declared number of load cycles and the declared stress.

#### 4.3.7 Bending strength

Bending strength,  $\sigma_b$ , shall be determined in accordance with EN 12089. No test result shall be less than the value given in Table 7 for the declared level.

Table 7 — Levels of bending strength

Level	Requirement kPa
BS50	≥ 50
BS75	≥ 75
BS100	≥ 100
BS115	≥ 115
BS125	≥ 125
BS135	≥ 135
BS150	≥ 150
BS170	≥ 170
BS200	≥ 200
BS250	≥ 250
BS350	≥ 350
BS450	≥ 450
BS525	≥ 525
BS600	≥ 600
BS675	≥ 675
BS750	≥ 750

#### 4.3.8 Thermal resistance and thermal conductivity

Thermal resistance and thermal conductivity shall be based upon measurements carried out in accordance with EN 12667 or EN 12939 for thick products.

For light weight fill applications without thermal insulation requirements it is permitted to declare the maximum thermal value as defined in the Scope of this European Standard (0,060 W/(m·K)).

The thermal resistance and the thermal conductivity shall be determined in accordance with Annex A and declared by the manufacturer according to the following:

- the reference mean temperature shall be 10 °C;
- the measured values shall be expressed with three significant figures;

NOTE      Zeros on the left hand side are not counted as significant figures.

- the thermal resistance,  $R_D$ , shall always be declared. The thermal conductivity,  $\lambda_D$ , shall be declared where possible;
- the declared thermal resistance,  $R_D$ , and the declared thermal conductivity,  $\lambda_D$ , shall be given as limit values representing at least 90 % of the production, determined with a confidence level of 90 %;
- the value of thermal conductivity,  $\lambda_{90/90}$ , shall be rounded upwards to the nearest 0,001 W/(m·K) and declared as  $\lambda_D$  in levels with steps of 0,001 W/(m·K);
- the declared thermal resistance,  $R_D$ , shall be calculated from the nominal thickness,  $d_N$ , and the corresponding thermal conductivity,  $\lambda_{90/90}$ , unless measured directly. For the calculation of the declared thermal conductivity,  $\lambda_D$ , related to the corresponding declared thickness, factors for the thickness effect conversions are given in Annex B;
- the value of thermal resistance,  $R_{90/90}$ , when calculated from the nominal thickness,  $d_N$ , and the corresponding thermal conductivity,  $\lambda_{90/90}$ , shall be rounded downwards to the nearest 0,05 m<sup>2</sup>·K/W, and declared as  $R_D$  in levels with steps of 0,05 m<sup>2</sup> K/W;
- the value of  $R_{90/90}$ , for those products for which only the thermal resistance is measured directly, shall be rounded downwards to the nearest 0,05 m<sup>2</sup> K/W, and declared as  $R_D$  in levels with steps of 0,05 m<sup>2</sup> K/W.

**4.3.9 Water absorption**

**4.3.9.1 Long term water absorption by immersion**

Long term water absorption by total immersion,  $W_{It}$ , shall be determined in accordance with EN 12087 method 2A. No test result shall exceed the value given in Table 8, for the declared level.

**Table 8 — Levels for long term water absorption by total immersion**

Level	Requirement % by volume
WL(T)5	≤5,0
WL(T)3	≤3,0
WL(T)1,5	≤1,5
WL(T)0,7	≤0,7

**4.3.9.2 Long term water absorption by diffusion**

Long term water absorption by diffusion,  $W_{dV}$ , shall be determined in accordance with EN 12088. No test result shall exceed the value given in Table 9, for the declared level.

Table 9 — Levels for long term water absorption by diffusion

Level	Requirement % by volume
WD(V)15	≤15
WD(V)10	≤10
WD(V)5	≤5
WD(V)3	≤3

#### 4.3.10 Freeze-thaw resistance

Freeze-thaw resistance shall be determined in accordance with EN 12091 using the test specimen from 4.3.9.2. The additional water absorption,  $W_V$ , shall be not higher than the value given in Table 10 for the declared level.

Table 10 — Levels for freeze-thaw resistance

Level	Requirement % by volume
FTC 5	≤5
FTC 4	≤4
FTC 3	≤3
FTC 2	≤2
FTC 1	≤1

After the freeze-thaw test the reduction in compressive stress at 10 % deformation,  $\sigma_{10}$ , of the dry specimens, when tested in accordance with EN 826 shall not exceed 10 % of the initial value.

#### 4.3.11 Water vapour transmission

Water vapour transmission properties shall be determined in accordance with EN 12086 and declared as the water vapour diffusion resistance factor,  $\mu$ , for homogeneous products and as the water vapour resistance,  $Z$ , for faced products. No test result shall be less than the declared value.

In the absence of measurements, the water vapour diffusion resistance factor,  $\mu$ , of EPS products may be chosen from Table E.3.

#### 4.3.12 Release of dangerous substances

NOTE See Annex ZA.

#### 4.3.13 Apparent density

Apparent density,  $\rho_a$ , shall be determined in accordance with EN 1602 when it is needed for indirect testing.

## 5 Test methods

### 5.1 Sampling

Test specimen shall be taken out of blocks according to the next specification: for fill sizes up to 500 m<sup>3</sup> respectively 1 000 m<sup>3</sup>: 3 respectively 5 blocks. For fill sizes greater than 1 000 m<sup>3</sup> a minimum number of 5 blocks to be taken.

Test specimens shall be taken from the same sample with a total area not less than 1 m<sup>2</sup> and sufficient to cover the needed tests. The shorter side of the sample shall not be less than 300 mm.

### 5.2 Conditioning

Conditioning of the test specimens shall be carried out for at least 6 h at (23 ± 5) °C unless otherwise specified in the test standard. In case of dispute, the test specimens shall be stored at (23 ± 2) °C and (50 ± 5) % relative humidity for at least 14 d prior to testing.

### 5.3 Testing

#### 5.3.1 General

Table 11 gives the dimensions and the minimum number of measurements required to get one test result and any specific conditions, which are necessary.

**Table 11 — Test methods, test specimens and conditions**

Dimensions in millimetres

No	Clause	Test method	Test specimen Length and width <sup>a, f</sup>	Minimum number of measurements to get one test result	Specific conditions
	Title				
4.2.1	Length and width	EN 822	Full-size	1	—
4.2.2	Thickness	EN 823	Full-size	1	load of (250 ± 5) Pa
4.2.3	Squareness	EN 824	Full-size	1	—
4.2.4	Flatness	EN 825	Full-size	1	—
4.2.5	Dimensional stability under specified temperature and humidity conditions	EN 1604	200 × 200	3	—
4.2.6, 4.3.3 and 4.3.4	Compressive stress at 2 % or 5 % and 10 % deformation; point load	EN 826	50 × 50 × 50	6	grinding
4.2.7 and 4.3.7	Bending strength	EN 12089	300 × 150 × 50 <sup>b</sup> or (5 × d + 50) × 150 × d <sup>c</sup>	3	Method B
4.2.8.1	Reaction to fire	See EN 13501-1			—

Table 11 (continued)

No	Clause		Test method	Test specimen Length and width <sup>a, f</sup>	Minimum number of measurements to get one test result	Specific conditions
	Title					
4.2.8.2	Continuous glowing combustion		g			
4.3.2.1	Dimensional stability under specified temperature and humidity		EN 1604	200 × 200	3	—
4.3.2.2	Deformation under specified compressive load and temperature conditions		EN 1605	50 × 50 × 50	3	Layers or coverings have to be cut off.
4.3.5	Compressive creep		EN 1606	300 × 300 × d <sup>e</sup>	2	grinding
4.3.6.1	Resistance to cyclic compressive loading with square wave load application		Annex D	400 × 400	3	
4.3.6.2	Resistance to cyclic compressive loading with sinus load application		EN 13793	200 × 200	3	
4.3.8	Thermal resistance and thermal conductivity		EN 12667 or EN 12939	See EN 12667 or EN 12939	1 <sup>d</sup>	—
4.3.9.1	Long term water absorption by immersion		EN 12087	200 × 200	3	Total: Method 1A and 2A
4.3.9.2	Long term water absorption by diffusion		EN 12088	500 × 500	1	-
4.3.10	Freeze-thaw resistance		EN 12091	200 × 200	6	Preparation by EN 12087
				50 × 50 × 50	3	Set B <sub>1</sub>
4.3.11	Water vapour transmission		EN 12086	100 × 100	5	Set B
4.3.12	Release of dangerous substances		g	—	—	—
4.3.13	Apparent density		EN 1602	Full-size	5	—
a	Full-size product thickness, except for 4.2.6, 4.2.7 and 4.3.4, 4.3.5 and 4.3.8.					
b	Sample size used for boards of 50 mm and above.					
c	For boards of thickness d < 50 mm.					
d	For calculation of the 90 % fractile and 90 % confidence level, the individual measurement shall be used.					
e	In real situations, applying large blocks, the compressive creep will be less than predicted by tests at these sample dimensions.					
f	Test specimen dimensions shall be determined in accordance with EN 12085.					
g	Not yet available.					

### 5.3.2 Thermal resistance - Thermal conductivity

Thermal resistance and thermal conductivity shall be determined in accordance with EN 12667 or EN 12939 for thick products and under the following conditions:

- at a mean temperature of  $(10 \pm 0,3)$  °C;
- after conditioning in an atmosphere of 23 °C and 50 % relative humidity;

NOTE Thermal resistance and the thermal conductivity may also be measured at mean temperatures other than 10 °C, providing that the accuracy of the relationship between temperature and thermal properties is sufficiently well documented.

Thermal resistance and thermal conductivity shall be measured directly at measured thickness. In the event that this is not possible, they shall be determined by measurements on other thicknesses of the product providing that:

- the product is of similar chemical and physical characteristics and is produced on the same production unit;
- and it can be demonstrated in accordance with EN 12939 that the thermal conductivity does not vary more than 2 % over the range of the thickness where the calculation is applied.

## 6 Designation code

A designation code for the product shall be given by the manufacturer. The following shall be included except when there is no requirement for a property described in 4.3:

— The expanded polystyrene abbreviated term	EPS
— This European Standard number	EN 14933
— Thickness tolerance	Ti
— Length tolerance	Li
— Width tolerance	Wi
— Squareness tolerance	Si
— Flatness tolerance	Pi
— Dimensional stability under specified temperature and humidity	DS(TH)i
— Compressive stress at 10 %, at 2 % and / or 5 % deformation	CS(10/2/ 5)i
— Bending strength	BSi
— Dimensional stability under laboratory condition	DS(N)i
— Deformation under specific compressive load and temperature	DLT(i)5
— Compressive creep	CC( $i_1/i_2/y$ ) $\sigma_c$
— Long term water absorption	WL(T)i



— Water absorption by diffusion	WD(V)i
— Water vapour diffusion transmission	MU <sub>i</sub> or Z <sub>i</sub>
— Resistance to cyclic compressive loading with square wave load	CLRT(I,z)σ <sub>i</sub>
— Resistance to cyclic compressive loading with sinus load	CLR(I,z)σ <sub>i</sub>
— Freeze-thaw resistance	FTC i

where “i” shall be used to indicate the relevant class or level, “z” is the number of cycles and “σ<sub>i</sub>” indicates the compressive stress applied for resistance to cyclic compressive loading. For compressive creep “σ<sub>c</sub>” shall be used to indicate the compressive stress and “y” to indicate the number of years.

NOTE The designation code for CE marking for expanded polystyrene is illustrated by the following example:

EPS – EN 14933– CS(10)250 – BS350 – DS(N)5

## 7 Evaluation of conformity

The manufacturer or his authorised representative shall be responsible for the conformity of his product with the requirements of this European Standard. The evaluation of conformity shall be carried out in accordance with EN 13172 and shall be based on factory production control and tests on samples taken at the factory.

If a manufacturer decides to group his products, it shall be done in accordance with EN 13172.

The minimum frequencies of tests in the factory production control shall be in accordance with Annex B of this standard. When indirect testing is used, the correlation to direct testing shall be established in accordance with EN 13172.

The conformity of the expanded polystyrene products with the requirements of this standard and with the stated values (including classes) shall be demonstrated by:

- initial type testing,
- factory production control by the manufacturer, including product assessment.

## 8 Marking and labelling

Products conforming with this standard shall be clearly marked, either on the product or on the label or on the packaging, with the following information:

- product name or other identifying characteristic;
- name or identifying mark and address of the manufacturer or his authorised representative;
- year of manufacture (the last two digits);
- shift or time of production and manufacturing plant or traceability code;
- reaction to fire class;
- declared thermal resistance;

## EN 14933:2007 (E)

- declared thermal conductivity;
- declared thickness;
- designation code as given in Clause 6;
- type of facing/ coating, if any;
- declared length, declared width;
- number of pieces and area in the package, as appropriate.

NOTE For CE marking and labelling see ZA.3.

## Annex A (normative)

### Determination of the declared values of thermal resistance and thermal conductivity

#### A.1 Introduction

It is the responsibility of the manufacturer to determine the declared values of thermal resistance and thermal conductivity. He will have to demonstrate conformity of the product to its declared values, except if a tabulated thermal value is declared for applications, where no thermal values are required.

The declared values of thermal conductivity and thermal resistance of a product are the expected values of these thermal properties during an economically reasonable working life under normal conditions, assessed through measured data at reference conditions.

#### A.2 Input data

The manufacturer shall have at least ten test measurements for thermal resistance or thermal conductivity, obtained from internal or external direct measurements in order to calculate the declared values. The direct thermal conductivity or thermal resistance measurements shall be carried out at regular intervals spread over a time period of at least twelve months. If less than ten test results is available, the period may be extended until ten test results are obtained, but with a maximum period of three years, within which the product and production conditions have not changed significantly.

For new products the ten thermal resistance or thermal conductivity test results shall be carried out spread over a minimum period of ten days.

The declared values shall be calculated according to the method given in A.3 and shall be recalculated at intervals not exceeding three months of production.

#### A.3 Declared values

##### A.3.1 General

The derivation of the declared values from the calculated values shall use the rules given in 4.2.1, which include the rounding conditions.

##### A.3.2 Case where thermal resistance and thermal conductivity are declared

The declared values shall be derived from the calculated values, which are determined using the equations A.1, A.2 and A.3.

$$\lambda_{90, 90} = \lambda_{\text{mean}} + k \times s_{\lambda} \quad (\text{A.1})$$

$$s_{\lambda} = \sqrt{\frac{\sum_{i=1}^n (\lambda_i - \lambda_{\text{mean}})^2}{n-1}} \quad (\text{A.2})$$

$$R_{90, 90} = d_D / \lambda_{90/90} \tag{A.3}$$

**A.3.3 Case where thermal resistance alone is declared**

The declared values shall be derived from the calculated value, which is determined using the Equations A.4 and A.5.

$$R_{90, 90} = R_{\text{mean}} - k \times s_R \tag{A.4}$$

$$s_R = \sqrt{\frac{\sum_{i=1}^n (R_i - R_{\text{mean}})^2}{n-1}} \tag{A.5}$$

**Table A.1 — Values for *k* for one sided 90 % tolerance interval with a confidence level of 90 %**

Number of test results	<i>k</i>
10	2,07
11	2,01
12	1,97
13	1,93
14	1,90
15	1,87
16	1,84
17	1,82
18	1,80
19	1,78
20	1,77
22	1,74
24	1,71
25	1,70
30	1,66
35	1,62
40	1,60
45	1,58
50	1,56
100	1,47
300	1,39
500	1,36
2.000	1,32
∞	1,282

Linear interpolation is acceptable. For other numbers of test results use ISO 12491.

## Annex B (normative)

### Factory production control

#### B.1 Testing frequencies

Table B.1 — Minimum product testing frequencies

Clause		Minimum testing frequency <sup>a</sup>
No	Title	
4.2.1	Length and width	1 per 2 h
4.2.2	Thickness	1 per 4 h
4.2.3	Squareness	1 per 8 h
4.2.4	Flatness	1 per 2 h
4.2.5	Dimensional stability under specified temperature and humidity conditions	1 per 5 years
4.2.6	Compressive stress at 10 % deformation or compressive strength	1 per 12 h
4.2.7 and 4.3.7	Bending strength	1 per day or 1 per 3 months
4.2.8.1	Reaction to fire	See Table B.2
4.2.8.2	Continuous glowing combustion	<sup>b</sup>
4.3.2.1	Dimensional stability under specified temperature and humidity conditions	1 per 5 years
4.3.2.2	Deformation under specified compressive load and temperature conditions	1 per 5 years
4.3.3 and 4.3.4	Compressive stress at 2% and/or 5% deformation or compressive strength and point load	1 per 12 h
4.3.5	Compressive creep	1 per 5 years
4.3.6.1	Resistance to cyclic compressive loading with square wave load application	1 per 5 years
4.3.6.2	Resistance to cyclic compressive loading with sinus load application	1 per 5 years
4.3.8	Thermal resistance and thermal conductivity	Initial values: 1 per 24 h <sup>c</sup>
4.3.9.1	Long term water absorption by immersion	1 per 5 years
4.3.9.2	Long term water absorption by diffusion	1 per 5 years
4.3.10	Freeze-thaw resistance	1 per 5 years

Table B.1 (continued)

Clause		Minimum testing frequency <sup>a</sup>
No	Title	
4.3.11	Water vapour transmission	1 per 5 years
4.3.12	Release of dangerous substances	<sup>b</sup>
4.3.13	Apparent density	1 per 12 h
NOTE For initial type testing of long term thermal, mechanical and freeze-thaw properties test results of similar products produced at different plants will be recognized until testing is complete.		
<sup>a</sup> The minimum testing frequencies shall be understood as the minimum for each production line under stable conditions. In addition to the testing frequencies given above, testing of relevant properties of the product shall be repeated when changes or modifications are made, that are likely to affect the conformity of the product. <sup>b</sup> Frequencies are not given, as harmonized European test methods are not yet available. <sup>c</sup> Only when thermal values are required.		

Table B.2 — Minimum product testing frequencies for the reaction to fire characteristics

Clause		Minimum testing frequency <sup>a</sup>							
No	Title	Direct testing <sup>b, c</sup>		Indirect testing <sup>d, e</sup>					
4.2.8	Reaction to fire class			Product		Components <sup>f, g</sup>			
		Substantial (EPS)				Non-substantial (Layers)			
		Test method	Frequency	Test method	Frequency	Test method	Frequency	Test method	Frequency
A1	EN ISO 1182 and EN ISO 1716 (and EN 13823)	1 per 2 years and indirect testing	—	—	Loss on ignition	1 per 4 h	Loss on ignition or calorific potential	1 per 4 h	1 per 4 h
					Apparent density	1 per 1 h	Weight unit per area	1 per 1 h	
A2	EN ISO 1182 or EN ISO 1716 and EN 13823	1 per 2 years and indirect testing	—	—	Loss on ignition	1 per 4 h	Loss on ignition or calorific potential	1 per 4 h	1 per 4 h
					Apparent density	1 per 1 h	Weight per unit area	1 per 1 h	
B, C, D	EN 13823 and EN ISO 11925-2	1 per month or 1 per 2 years and indirect testing	—	—	—	—	—	—	—
					EN ISO 11925-2	1 per day <sup>h</sup>	Apparent density and thickness	1 per 2 h	weight per unit area
		1 per day <sup>h</sup>	—	—	—	—	—	—	—

**EN 14933:2007 (E)**

**Table B.2 (continued)**

Clause		Minimum testing frequency <sup>a</sup>							
No	Title	Direct testing <sup>b, c</sup>		Indirect testing <sup>d, e</sup>					
				Product		Components <sup>f, g</sup>			
		Test method	Frequency	Test method	Frequency	Substantial (EPS)		Non-substantial (Layers)	
						Test method	Frequency	Test method	Frequency
4.2.8	Reaction to fire class	EN ISO 11925-2	1 per day <sup>h</sup>	—	—	—	—	—	—
	E	—	—	—	—	—	—	—	—
	F	—	—	—	—	—	—	—	—

NOTE Not all Euroclasses may apply for the products conforming to this standard.

<sup>a</sup> The minimum testing frequencies, expressed in test results, shall be understood as the minimum for a product or product group for each production unit/line under stable conditions. In addition to the testing frequencies given above, testing of relevant properties of the product shall be repeated when changes or modifications are made that are likely to affect the conformity of the product.

<sup>b</sup> Direct testing may be conducted either by third party or by the manufacturer.

<sup>c</sup> Direct testing may also be the reference scenario Room-corner test ISO 9705:1993, *Fire tests — Full scale room test for service products*.

<sup>d</sup> Indirect testing is only possible in the case of products falling within the system 1 for attestation of conformity of reaction to fire, or by having a notified body verifying the correlation to the direct testing.

<sup>e</sup> Indirect testing may be either on the product or on its components.

<sup>f</sup> Definition as given in the Euroclasses Decision 2000/147/EC:  
 Substantial component: A material that constitutes a significant part of a non-homogeneous product. A layer with a mass per unit area  $\geq 1,0 \text{ kg/m}^2$  or a thickness  $\geq 1,0 \text{ mm}$  is considered to be a substantial component.  
 Non-substantial component: A material that does not constitute a significant part of a non-homogeneous product. A layer with a mass per unit area  $< 1,0 \text{ kg/m}^2$  and a thickness  $< 1,0 \text{ mm}$  is considered to be a non-substantial component.

<sup>g</sup> In case of certified component, no testing is required.

<sup>h</sup> In case of certified raw material the frequency is once per week.



## B.2 Indirect testing

### B.2.1 General

If indirect testing is used the correlation between the directly tested and the indirect property shall be known and the approach shall be calculated on a one sided 90 % tolerance interval.

NOTE In this context compressive stress by 10 % deformation and thermal conductivity may be evaluated indirectly using the apparent density and its established mathematical correlation to these properties. For the relationship between compressive stress at 10 % deformation and apparent density and thermal conductivity and apparent density there is a large amount of data collected in Europe. The curves in Figures B.1 and B.2 have been calculated on this European data to which every manufacturer may refer. If a manufacturer wants to use his own data, he should calculate and record the approach for a prediction interval,  $1 - \alpha$ , of 90 %.

### B.2.2 Compressive stress at 10 % deformation

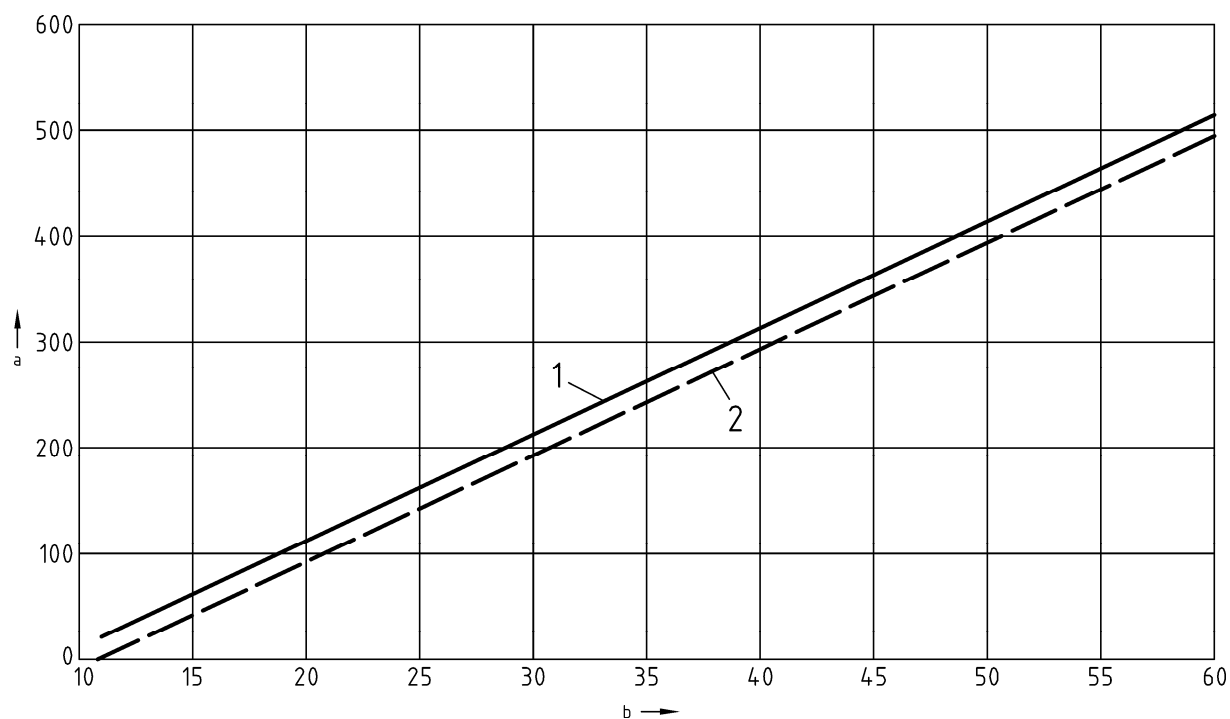

#### Key

- a Compressive stress  $\sigma_{10}$  [kPa]
- b Apparent density  $\rho_a$  [kg/m<sup>3</sup>]
- 1 Compressive stress
- 2 Predicted compressive stress

**Figure B.1 — Relationship between compressive stress at 10 % deformation and apparent density for indirect testing;  $1 - \alpha = 0,90$ ;  $n = 495$**

Regression for  $\rho_a \geq 11$  kg/m<sup>3</sup>:

$$\sigma_{10, \text{mean}} = 10,0 \text{ kPa} \cdot \text{m}^3/\text{kg} \times \rho_a - 81,0 \text{ kPa} \quad (\text{B.1})$$

$$\sigma_{10, \text{pred}} \approx 10,0 \text{ kPa} \cdot \text{m}^3/\text{kg} \times \rho_a - 109,1 \text{ kPa} \text{ [kPa]} \quad (\text{B.2})$$

**B.2.3 Thermal conductivity**

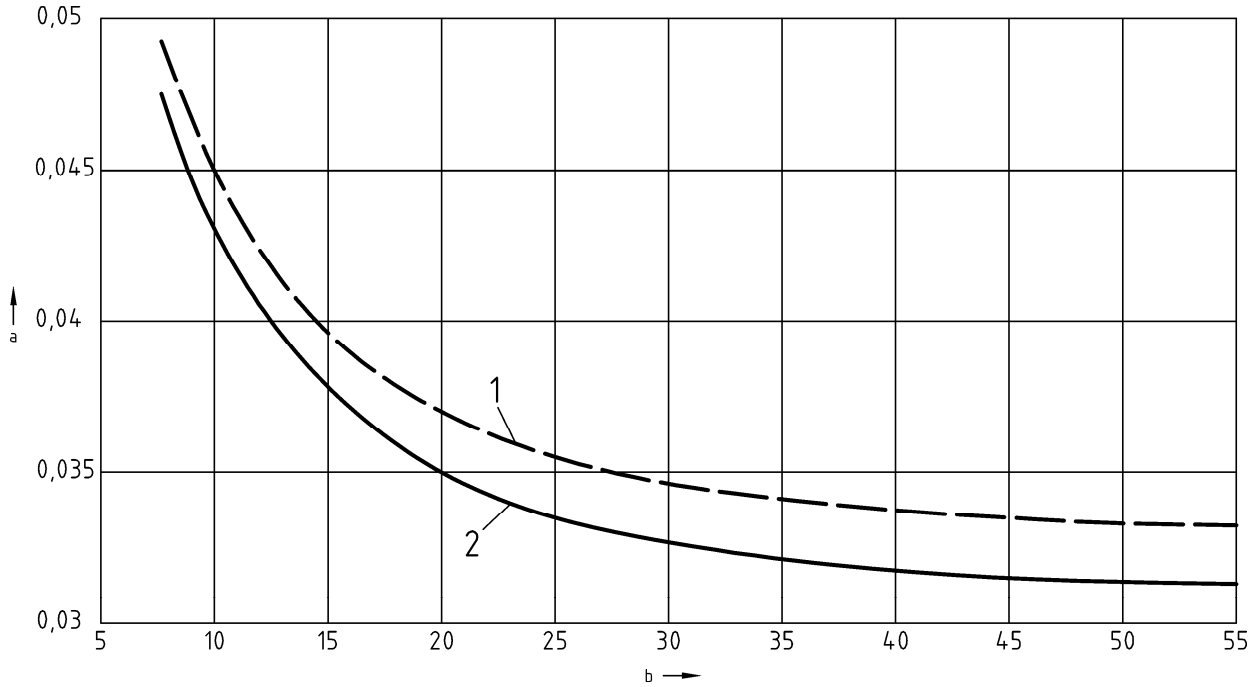

**Key**

- a Thermal conductivity  $\lambda$  (W/(m · K))
- b Apparent density  $\rho_a$  (kg/m<sup>3</sup>)
- 1 Predicted thermal conductivity
- 2 Mean thermal conductivity

**Figure B.2 — Relationship between declared thermal conductivity (at 50 mm reference thickness) and apparent density;  $1 - \alpha = 0,90$ ;  $n = 3873$**

Regression for  $8 \text{ kg/m}^3 \leq \rho_a \leq 55 \text{ kg/m}^3$ :

$$\lambda_{\text{mean}} = 0,025314 \text{ W/(m} \cdot \text{K)} + 5,1743 \cdot 10^{-5} \text{ Wm}^2/(\text{kgK}) \times \rho_a + 0,173606 \text{ Wkg}/(\text{m}^4\text{K}) / \rho_a \text{ [W/(m} \cdot \text{K)}] \quad (\text{B.3})$$

$$\lambda_{\text{pred}} = 0,027167 \text{ W/(m} \cdot \text{K)} + 5,1743 \cdot 10^{-5} \text{ Wm}^2/(\text{kgK}) \times \rho_a + 0,173606 \text{ Wkg}/(\text{m}^4\text{K}) / \rho_a \text{ [W/(m} \cdot \text{K)}] \quad (\text{B.4})$$

## Annex C (normative)

### Product classification

EPS-Products are divided into types as shown in Table C.1. Each type shall satisfy two different conditions at the same time in order to ensure adequate product performance.

**Table C.1 — Classification of EPS products**

Type	Compressive stress at 10 % deformation kPa	Bending strength kPa
EPS 40	40	60
EPS 50	50	75
EPS 60	60	100
EPS 70	70	115
EPS 80	80	125
EPS 90	90	135
EPS 100	100	150
EPS 120	120	170
EPS 150	150	200
EPS 200	200	250
EPS 250	250	350
EPS 300	300	450
EPS 350	350	525
EPS 400	400	600
EPS 450	450	675
EPS 500	500	750

NOTE Only if the classification requirements given in Table C.1 are fulfilled, the properties given in D.1 apply.

## Annex D (normative)

### Determination of behaviour under cyclic square-wave load

#### D.1 Scope

This method specifies procedures for determining the compressive deformation of cellular plastic during a fatigue test carried out under cyclic compressive loading with a square-wave load. The method is primarily designed for material intended for use in railway embankments.

NOTE This method is essentially based on the Swedish test method SP 2687, *Resistance to cyclic compressive loading with square-wave load*.

#### D.2 Definitions

For the purposes of this annex, the following definitions apply:

##### D.2.1

##### **thickness, $t_0$**

thickness of the test specimen (mean value from the four corners) before testing at 100 % of the maximal compressive stress,  $\sigma_{\max}$

##### D.2.2

##### **compressive deformation, $l_{i1}$**

compressive deformation of the test specimen after  $i$  number of cycles at 100 % of the maximum compressive stress,  $\sigma_{\max}$ , when four gauges are used take mean value from the four corners

##### D.2.3

##### **compressive stress**

$\sigma_{\min}$ : Lower stress level of one stress cycle

$\sigma_{\max}$ : Upper stress level of one stress cycle

##### D.2.4

##### **relative compressive deformation, $D_i$**

relative reduction in thickness (%) of the test specimen after  $i$  number of cycles

##### D.2.5

##### **stress cycle**

cycle during which the compressive force is applied to the test specimen, starting at  $\sigma_{\min}$ , to be increased to  $\sigma_{\max}$  and then reduced back to  $\sigma_{\min}$ , so that the cycle of loading and unloading describes a type of an almost square wave, where  $\sigma_{\min}$  is the bottom and  $\sigma_{\max}$  is the top of the wave

##### D.2.6

##### **resistance to cyclic compressive load, $D$**

resistance to cyclic compressive load is defined as the relative compressive deformation after  $2 \cdot 10^6$  cycles of a specific square wave-type alternating compressive load

### D.3 Principle

A test specimen is subjected to a cyclic compressive load of constant amplitude. The compressive load is applied axially with a cyclic variation between two prescribed values and a frequency of 4 Hz. The variation in load is almost a square wave oscillating between two constant compressive loads. The duration of the test is  $2 \cdot 10^6$  cycles. At certain intervals the compressive deformation of the specimen is measured while keeping the specimen under a steady compressive load equal to 100 % of the maximum applied load. At the end of the test the total compressive deformation is measured and then divided by the initial thickness of the specimen at 100% of the max. test load to obtain the relative compressive deformation.

### D.4 Testing equipment

#### D.4.1 Cutting tool

Cutting tool providing smooth and perpendicular surfaces and preventing melting of the material during cutting.

#### D.4.2 Length measuring equipment

Instrument for measuring the test specimen length and width to an accuracy of  $\pm 1,0$  mm and instrument for measuring the test specimen thickness to an accuracy of  $\pm 0,1$  mm.

#### D.4.3 Steel plate

Stainless steel plate for load distribution, with the following dimensions: 400x 400 x 50  $\pm 1,0$  mm. The lower surface shall be face-ground.

#### D.4.4 Measuring gauges

Measuring gauges for measuring deformation, with an accuracy of  $\pm 0,01$  mm within the range of use for this test or corresponding instruments, with same accuracy, for measuring the compression of the specimen.

#### D.4.5 Apparatus

Load cell equipped hydraulic testing machine, with rigid construction, capable of applying cyclic loading in accordance with the requirements below:

- a) Frequency of the loading cycle at least 4 Hz.
- b) Almost square-wave load cycle, with a pulse rise time of  $\leq 20$  ms from the minimum up to 90 % of the maximum load, as shown in Figure D.1.
- c) Force control within  $\pm 1$  % of the maximum applied force.

The load shall be transferred to the specimen through a spherical coupling connected to the load cell, as shown in the test set-up in Figure D.3.

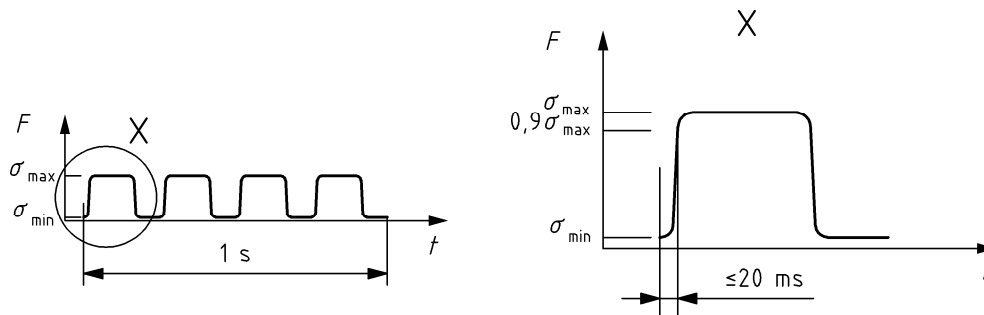

Figure D.1 — Required load cycle during the fatigue test

## D.5 Test specimens

### D.5.1 Dimensions of test specimens

Test specimens with dimensions  $400 \times 400 \text{ mm} \pm 1,0 \text{ mm}$  shall be taken from the middle of the cellular plastic boards. A test specimen consists of *one* unit of the chosen thickness.

### D.5.2 Number of test specimens

At least 2 test specimens shall be tested for each type and quality of cellular plastic. The test specimens shall be taken from different cellular plastic boards.

### D.5.3 Conditioning of test specimens

After cutting, the test specimens shall be conditioned for at least 45 days at the temperature of  $(22 \pm 2) ^\circ\text{C}$  and the relative humidity of  $(50 \pm 10)\%$ . The testing shall be carried out during the same climatic conditions.

## D.6 Procedure

### D.6.1 Test conditions

The test shall be carried out at  $(22 \pm 2) ^\circ\text{C}$  and  $(50 \pm 10) \%$  relative humidity.

### D.6.2 Test procedure

Measure the lengths and widths 5 mm from upper and 5 mm from lower surface and 50 mm from side edges, total 8 measurements, see Figure D.2. Calculate the area of the load-bearing surfaces (upper and lower surface) and take mean value from the two areas. Measure the thickness of the test specimen in 4 points T1-T4 and take mean value from readings. Place the test specimen (one board) on the lower machine plate.

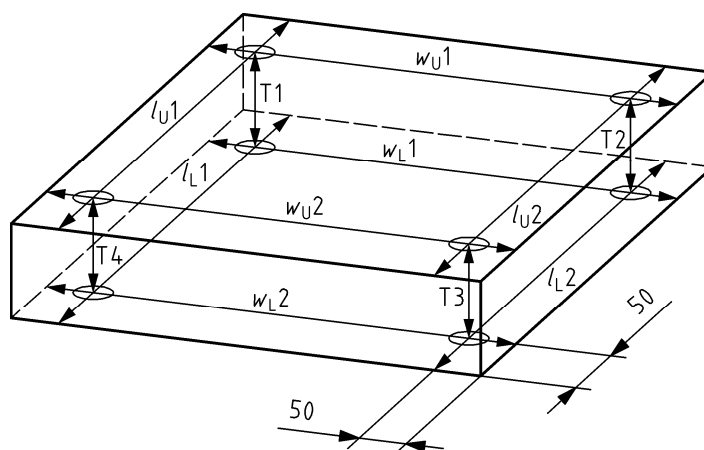

### Key

Area upper surface =  $(l_{U1} + l_{U2})/2 * (w_{U1} + w_{U2})/2$

Area lower surface =  $(l_{L1} + l_{L2})/2 * (w_{L1} + w_{L2})/2$

Measuring of lengths  $l$  and widths  $w$  shall be done 5 mm from upper and lower surface and 50 mm from side edges, total 8 measurements

**Figure D.2 — Dimensions of the test specimen**

Place the test specimen concentric with the load axis and place the steel load-distribution plate on top (see Figure D.3). Both test specimen and steel plate shall be carefully centred to ensure concentric application of the load.

Place the measuring gauges to record the movements of the upper surface of the load-distribution plate at four points located close to the four corners (see Figure D.3). The readings on the measuring gauges indicate the vertical deformation of the sample. Mark the exact location of each measuring point on the steel plate to ensure the repeatability of the measurements throughout the test.

An alternative method for measuring the compression of the test specimen is to use one measuring gauge in the middle of the test specimen.

Apply a steady compressive stress of 100 % of the maximum test load. The maximum test load is the load from the weight of the steel plate itself, plus the load from the test machine. Reset the measuring gauge(s) and measure the thickness of the test specimen ( $t_0$ ) rounded to the nearest 0,1 mm, the thickness shall be the mean value from the four corners.

Start the cyclic loading as a uniaxial concentric compression with constant amplitude and frequency (see Figure D.1). Required characteristics of the load cycle are:

- The frequency is 4 Hz.
- The stress-time relationship is described by an almost square-wave cycle, with a pulse rise time  $\leq 20$  ms from the minimum compression level to 90 % of the maximum compression level (see Figure D.1).

Take readings from the measuring gauge(s), at  $i = 10$  cycles,  $i = 10,000$  and as close as possible to 100,000, 300,000, 600,000, 1,500,000 and 2,000,000 cycles, while keeping the specimen under a steady compressive load of 100 % of the maximum test load. Note the readings in mm to two decimals.

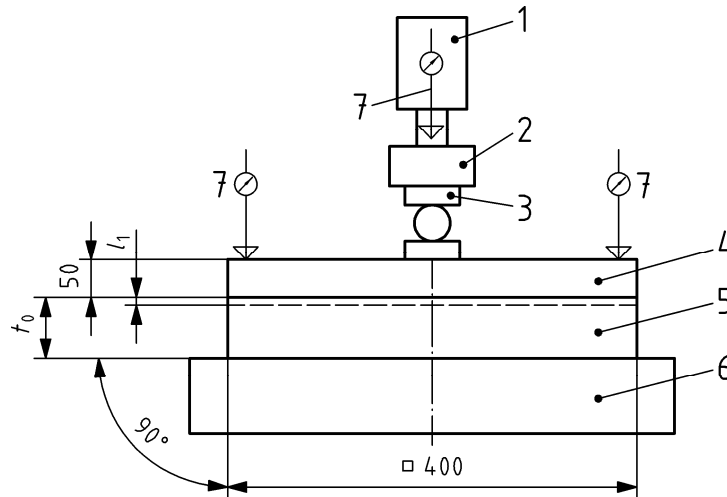

$t_0$  = Thickness of test specimen (mean four corners) before cyclic load

$l_1$  = The compressive deformation after  $2 \cdot 10^6$  compressive loads

**Key**

- 1 Actuator
- 2 Load cell
- 3 Spherical
- 4 Steel
- 5 Test specimen (1 board)
- 6 Machine
- 7 Measuring gauge(s) for compressive deformation of the specimens: one in each corner, one in the middle of the test

**Figure D.3 — Test set-up**

**D.7 Calculation and expression of results**

The relative compressive deformation at each test level is calculated according to the following equation and shall be expressed to two significant figures.

$$D_i = 100 \times \frac{l_{1i}}{t_0} (\%)$$

where:

- $t_0$  The thickness of the test specimen (mean value from the four corners) before testing at 100 % of the maximum test load.
- $l_{1i}$  The compressive deformation of the test specimen after i number of cycles at 100 % of the maximum test load, when four gauges are used take mean value from the four corners.
- $D_i$  The relative compressive deformation (%) after i number of cycles.

The relationship between deformation - number of cycles shall be presented in a diagram from 0 to  $2 \cdot 10^6$  cycles.

The result is the relative compressive deformation D (%) after  $2 \cdot 10^6$  cycles.



## D.8 Accuracy of measurement

Under cyclic loading the accuracy of the maximum applied load has to be within  $\pm 1$  %. The measuring gauge(s), for measuring the compression of the specimen, shall have an accuracy within  $\pm 0,01$  mm. The accuracy in measuring the specimen width shall be within  $\pm 1$  mm. The accuracy in measuring the specimen height before testing shall be within  $\pm 0,1$  mm.

## D.9 Test report

The test report shall include the following information, if relevant:

- reference to this European Standard;
- name and address of the testing laboratory;
- identification number of the test report;
- name and address of the organization or the person who ordered the test;
- purpose of the test;
- method of sampling and other circumstances (date and person responsible for the sampling);
- name and address of the manufacturer or supplier of the tested product;
- name or other identification of the product;
- description of the tested product;
- date of supply of the tested product;
- date of the testing;
- test method and selected stress levels,  $\sigma_{\min}$  and  $\sigma_{\max}$ ;
- any deviation from the test method;
- test results lengths, widths and thickness before testing, the relationship between deformation - number of cycles and the relative compressive deformation  $D$  (%) after  $2 \cdot 10^6$  cycles;
- any other information that could influence the assessment of the test result;
- accuracy of the test result.

## Annex E (informative)

### Additional properties

#### E.1 General

In addition to the product characteristics given in Clause 4 of this standard, designers and users of materials may also require additional information of relevance to their proposed application.

The design thermal conductivity,  $\lambda_U$ , should be calculated from the declared thermal conductivity,  $\lambda_D$ , using EN ISO 10456, *Building materials and products — Procedures for determining declared and design thermal values (ISO 10456:1999)* for different temperatures and moisture contents.

The following information and product requirements may be useful in providing standardised assessment procedures.

#### E.2 Compressive modulus of elasticity

Modulus of elasticity in compression,  $E$ , should be determined perpendicular to the faces of the product in accordance with EN 826 *Thermal insulating products for building applications — Determination of compression behaviour*. If the modulus of elasticity in compression is declared, no test result should be lower than the declared value CM. For details see Table E.2

#### E.3 Determination of shear strength

A correlation between bending strength and the shear strength,  $\tau$ , is given in Table D.1. The shear strength should otherwise be determined in accordance with EN 12090, *Thermal insulating products for building applications — Determination of shear behaviour*. For details see Table E.2

**Table E.1 — Correlation between bending strength and shear strength**

Bending strength $\sigma_B$ requirement kPa	Shear strength $\tau$ correlation kPa
50	25
75	35
100	50
115	55
125	60
135	65
150	75
170	85

Table E.1 (continued)

Bending strength $\sigma_B$ requirement kPa	Shear strength $\tau$ correlation kPa
200	100
250	125
350	170
450	225
525	260
600	300
675	335
750	375

Table E.2 — Test methods, test specimens, conditions and minimum testing frequencies

Dimensions in millimetres

Clause		Test method	Test Specimens length and width <sup>a</sup>	Minimum Number of measurements to get one test result	Specific Conditions	Factory production control Minimum product testing frequencies <sup>b</sup>
No	Title					
E.2	Compressive modulus of elasticity	EN 826	100 × 100	5	condition specimen for 45 days	1 per 5 years
			150 × 150	3		
E.4	Shear strength	EN 12090	250 x 50 x thickness, (max.50 thick)	5	Single Specimen	1 per 5 years
			200 x 100 x thickness (max.50 thick)	3	Double Specimen	

<sup>a</sup> Unless stated otherwise the dimensions include the declared thickness.

<sup>b</sup> Only relevant in case of declaration of the property.

#### E.4 Long-term compressive behaviour

EPS products meeting the requirements of Table C.1 are expected to have a compressive creep deformation of 2 % or less after 50 years, when subjected to a permanent compressive stress of  $0,30 \sigma_{10}$ .

NOTE 1 See Struik, L. C. E., *Physical aging in amorphous polymers and other materials*, Elsevier Scientific Publishing Company, 1978.

NOTE 2 Compressive creep in reality will be less than predicted by the above testing results of small samples due to stiffening of the matrix and the volume effect of blocks used.

## E.5 Water vapour diffusion resistance factor

Instead of testing the water vapour diffusion resistance factor according to EN 12086, tabulated values according to Table E.3 may be used.

**Table E.3 — Tabulated values of water vapour diffusion resistance index and water vapour permeability**

EPS Type	Water vapour diffusion resistance factor $\mu_1$	Water vapour permeability $\delta$ mg/(Pa·h·m)
EPS 40	20 to 40	0,018 to 0,036
EPS 50	20 to 40	0,018 to 0,036
EPS 60	20 to 40	0,018 to 0,036
EPS 70	20 to 40	0,018 to 0,036
EPS 80	20 to 40	0,018 to 0,036
EPS 90	30 to 70	0,010 to 0,024
EPS 100	30 to 70	0,010 to 0,024
EPS 120	30 to 70	0,010 to 0,024
EPS 150	30 to 70	0,010 to 0,024
EPS 200	40 to 100	0,007 to 0,018
EPS 250	40 to 100	0,007 to 0,018
EPS 300	40 to 100	0,007 to 0,018
EPS 350	40 to 100	0,007 to 0,018
EPS 400	40 to 100	0,007 to 0,018
EPS 450	40 to 100	0,007 to 0,018
EPS 500	40 to 100	0,007 to 0,018

## E.6 Additional information

EPS and any laminates containing it should not come into contact with any materials in the building which reacts with the EPS causing it to dissolve or swell as can be the case with e.g. some solvent based adhesives, wood preservatives and other substances.

EPS complies with the compositional requirements given in the working document of the Service of the Commission "Construction Products and Regulations on Substances Classified as Dangerous".

When installing EPS products, no special precautions need to be taken by the operatives as they are non irritant and non toxic.

EPS products can easily be trimmed on site using normal cutting tools.

## Annex ZA (informative)

### Relationship between this European Standard and the Essential Requirements of EU Directive 89/106/EEC, EU Construction Products Directive

#### ZA.1 Scope and relevant characteristics

This European Standard has been prepared under a mandate given to CEN by the European Commission and the European Free Trade Association.

The clauses of this European Standard, shown in the table below, meet the requirements of the Mandate M/103 its addendum M/138 and Mandates M/126 and M/130 given under the EU Construction Products Directive (89/106/EEC).

Compliance with these clauses confers a presumption of fitness of the construction product covered by this annex for the intended uses indicated herein; reference shall be made to the information accompanying the CE marking.

**WARNING — Other requirements and other EU Directives, not affecting the fitness for intended uses, can be applicable to the construction products falling within the scope of this European Standard.**

NOTE 1 In addition to the specific clauses relating to dangerous substances contained in this standard, there may be other requirements applicable to the products falling within its scope (e.g. transposed European legislation and national laws, regulations and administrative provisions). In order to meet the provisions of the EU Construction Products Directive, these requirements need also to be complied with, when and where they apply.

NOTE 2 An informative database of European and national provisions on dangerous substances is available at the Construction web site on EUROPA (accessed through <http://europa.eu.int/comm/enterprise/construction/internal/dangsub/dangmain.htm>).

This annex establishes the conditions for the CE marking of the expanded polystyrene intended for the uses indicated in Table ZA.1 and shows the relevant clauses applicable.

This annex has the same scope as Clause 1 of this standard and is defined by Table ZA.1.

Table ZA.1 — Relevant clauses

Construction Products: <b>Factory made products of expanded polystyrene</b>			
Intended use: <b>Thermal insulation and light weight fill products for civil engineering applications</b>			
<b>Requirement/Characteristic from the mandate</b>	<b>Requirement clauses in this European Standard</b>	<b>Mandated classes or levels</b>	<b>Technical classes/levels/limit values <sup>a</sup></b>
Reaction to fire	4.2.8.1 Reaction to fire	Euroclasses	—
Continuous glowing combustion	4.2.8.2 Continuous glowing combustion	Glowing classes	
Resistance to dynamic loading	4.3.6 Resistance to cyclic compressive loading	—	Limit values
Water permeability	4.3.9 Water absorption	—	Levels
Release of dangerous substances to the indoor environment	4.3.12 Release of dangerous substances	—	—
Thermal resistance	4.3.8 Thermal resistance and thermal conductivity	—	Limit values
	4.2.2 Thickness	—	Classes
Water vapour permeability	4.3.11 Water vapour transmission	—	Tabulated values
Compressive strength	4.2.6 and 4.3.3 Compressive stress at 10 % and 2 % or 5 % deformation	—	Levels
Tensile/Flexural strength	4.2.7 Bending strength <sup>d</sup>	—	Limit value
	4.3.2 Bending strength	—	Levels
Durability of reaction to fire against heat, weathering, ageing/degradation	— <sup>b</sup>	—	<sup>b</sup>
Durability of thermal resistance against heat, weathering, ageing/degradation	4.3.8 Thermal resistance and thermal conductivity	—	Limit values
	4.2.5 and 4.3.2.1 Dimensional stability under specified temperature and humidity conditions	—	Levels
	4.3.2.2 Deformation under specified compressive load and temperature conditions	—	Levels <sup>c</sup>
	4.3.10 Freeze-thaw resistance	—	Levels
Durability of compressive strength against ageing and degradation	4.3.5 Compressive creep	—	Limit value
	4.3.10 Freeze-thaw resistance	—	Levels
Durability of resistance to dynamic loads	4.3.6 Resistance to cyclic compressive loading	—	Limit value

Table ZA.1 (continued)

Construction Products: <b>Factory made products of expanded polystyrene</b>			
Intended use: <b>Thermal insulation and light weight fill products for civil engineering applications</b>			
<b>Requirement/Characteristic from the mandate</b>	<b>Requirement clauses in this European Standard</b>	<b>Mandated classes or levels</b>	<b>Technical classes/levels/limit values <sup>a</sup></b>
Durability against chemicals and biological attack	<sup>e</sup>	-	-
<p><sup>a</sup> The 'no performance determined' (NPD) option may be used when and where the characteristic, for a given intended use, is not subject to regulatory requirements.</p> <p><sup>b</sup> No change in reaction to fire properties for EPS products.</p> <p><sup>c</sup> Only in respect of the thickness.</p> <p><sup>d</sup> For handling and installation.</p> <p><sup>e</sup> Durability of expanded polystyrene against chemicals and biological attack as a result of natural occurrence is given.</p>			

The requirement on a certain characteristic is not applicable in those Member States (MSs) where there are no regulatory requirements on that characteristic for the intended use of the product. In this case, manufacturers placing their products on the market of these MSs are not obliged to determine nor declare the performance of their products with regard to this characteristic and the option "No performance determined" (NPD) in the information accompanying the CE marking (see ZA.3) may be used. The NPD option may not be used, however, where the characteristic is subject to a threshold level.

## **ZA.2 Procedures for attestation of conformity of expanded polystyrene products**

### **ZA.2.1 Systems of attestation of conformity**

For products having more than one of the intended uses specified in the following families, the tasks for the approved body, derived from the relevant systems of attestation of conformity, are cumulative.

The system of attestation of conformity for the factory made EPS products indicated in Table ZA.1 in accordance with the decision of the European Commission decision 95/204/EC of 30.04.95 revised by decision 99/91/EC of 25.01.99 and by the Commission Decision 2001/596/EEC as given in Annex III of the mandate M103 as amended by mandates M126 and M130 is shown in Table ZA.2 for the indicated intended use(s).

Table ZA.2 — System(s) of attestation of conformity

Product(s)	Intended use(s)	Level(s) or class(es) (reaction to fire)	Attestation of conformity system(s)
Thermal insulation and light weight fill products for civil engineering applications	For uses subject to regulations on reaction to fire	A1 <sup>a</sup> , A2 <sup>a</sup> , B <sup>a</sup> , C <sup>a</sup> A1 <sup>b</sup> , A2 <sup>b</sup> , B <sup>b</sup> , C <sup>b</sup> , D, E (A1 to E) <sup>c</sup> , F	1 3 3 (with 4 for RtF)
	Any	-	3
System 1: See Directive 89/106/EEC (CPD) Annex III.2.(i), without audit testing of samples. System 3: See Directive 89/106/EEC (CPD) Annex III.2.(ii), Second possibility. System 4: See Directive 89/106/EEC (CPD) Annex III.2.(ii), Third possibility.			
<sup>a</sup> Products/materials for which a clearly identifiable stage in the production process results in an improvement of the reaction to fire classification (e.g. an addition of fire retarders or a limiting of organic material) <sup>b</sup> Products/materials not covered by footnote 1 <sup>c</sup> Products/materials that do not require to be tested for reaction to fire e.g. (Products/materials of classes A1 according to the Decision 96/603/EC, as amended).			

The attestation of conformity of the thermal insulation products for civil engineering applications in Table ZA.1 shall be based on the evaluation of conformity procedures indicated in Table(s) ZA.2.1 to ZA.2.2 resulting from application of the clauses of this or other European standard indicated therein.

Where more than one table applies for the product (i.e. because its intended use makes different characteristics relevant), Table ZA.2.1 has to be read in conjunction with subsequent tables in order to determine which characteristics assigned to the manufacturer in Table ZA.2.1 are type tested by a notified test lab (system 3) and which by the manufacturer (system 4).



Table ZA.2.1 — Assignment of evaluation of conformity tasks for products under system 1

Tasks		Content of the task	Evaluation of conformity clauses of EN 13172 to apply in addition to Clause 7 and Annex B of this standard
Tasks for the manufacturer	Factory production control (FPC)	Parameters related to all relevant characteristics of Table ZA.1	Clauses 1 to 5, Annexes B and C of EN 13172:2001 Annex B of this standard
	Further testing of samples taken at factory	All relevant characteristics of Table ZA.1	Annex B of this standard
	Initial type testing	Those relevant characteristics of Table ZA.1 not tested by the notified body	Clause 6 of EN 13172:2001
Tasks for the notified body	Initial type testing	<ul style="list-style-type: none"> <li>- Reaction to fire</li> <li>- Thermal resistance</li> <li>- Release of dangerous substances<sup>a</sup></li> <li>- Compressive strength (for load bearing applications)</li> <li>- Water permeability</li> <li>- resistance to dynamic load</li> </ul>	Clause 6 of EN 13172:2001
	Initial inspection of factory and of FPC	Parameters related to all relevant characteristics of Table ZA.1, in particular reaction to fire	Annex B and C of EN 13172:2001 and Annex B of this standard
	Continuous surveillance, assessment and approval of FPC.	Parameters related to all relevant characteristics of Table ZA.1, in particular reaction to fire	Annex B and C of EN 13172:2001 and Annex B of this standard

<sup>a</sup> No test method available as yet

**Table ZA.2.2 — Assignment of evaluation of conformity tasks for products under system 3 and 3 (with 4 for RtF)**

Tasks		Content of the task	Evaluation of conformity clauses of EN 13172 to apply in addition to Clause 7 and Annex B of this standard
Tasks under the responsibility of the manufacturer	Factory production control (FPC)	Parameters related to all relevant characteristics of Table ZA.1	Annex B of this standard and Clauses 1 to 5 of EN 13172:2001 and: For system 3 Annex C of EN 13172:2001 For system 3 (with 4 for RtF) Annex C & D of EN 13172:2001
	Initial type testing by the manufacturer	"Those relevant characteristics of Table ZA.1 not tested by the notified body" including reaction to fire for system 3 & 4)	Clause 6 of EN 13172:2001
	Initial type testing by a notified test laboratory	- Reaction to fire (system 3) - Thermal resistance - Release of dangerous substances <sup>a</sup> - Compressive strength (for load bearing applications) - Water permeability - resistance to dynamic load	Clause 6 of EN 13172:2001
<sup>a</sup> No test method available as yet			

**ZA.2.2 EC certificate and declaration of conformity**

In case of products under system 1 or (1 and 3): When compliance with the conditions of this annex is achieved, the certification body shall draw up a certificate of conformity (EC Certificate of conformity), which entitles the manufacturer to affix the CE marking. The certificate shall include:

- name, address and identification number of the certification body;
- name and address of the manufacturer, or his authorised representative established in the EEA, and place of production;

NOTE 1 The manufacturer may also be the person responsible for placing the product onto the EEA market, if he takes responsibility for CE marking.

- description of the product (type, identification, use, ...);
- provisions to which the product conforms (e.g. Annex ZA of this EN);
- particular conditions applicable to the use of the product (e.g. provisions for use under certain conditions, etc.);
- the number of the certificate;
- conditions and period of validity of the certificate, where applicable;

- name of, and position held by, the person empowered to sign the certificate.

In addition, the manufacturer shall draw up a declaration of conformity (EC Declaration of conformity) including the following:

- name and address of the manufacturer, or his authorised representative established in the EEA;
- name and address of the certification body;
- description of the product (type, identification, use, ...), and a copy of the information accompanying the CE marking;

NOTE 2 Where some of the information required for the Declaration is already given in the CE marking information, it does not need to be repeated.

- provisions to which the product conforms (e.g. Annex ZA of this EN);
- particular conditions applicable to the use of the product (e.g. provisions for use under certain conditions, etc.);
- number of the accompanying EC Certificate of conformity;
- name of, and position held by, the person empowered to sign the declaration on behalf of the manufacturer or of his authorised representative.

In case of products under system 3 or (3 and 4)): When compliance with the conditions of this annex is achieved, the manufacturer or his agent established in the EEA shall prepare and retain a declaration of conformity (EC Declaration of conformity), which entitles the manufacturer to affix the CE marking. This declaration shall include:

- name and address of the manufacturer, or his authorised representative established in the EEA, and place of production;

NOTE 3 The manufacturer may also be the person responsible for placing the product onto the EEA market, if he takes responsibility for CE marking.

- description of the product (type, identification, use,...), and a copy of the information accompanying the CE marking;

NOTE4 Where some of the information required for the Declaration is already given in the CE marking information, it does not need to be repeated.

- provisions to which the product conforms (e.g. Annex ZA of this EN);
- particular conditions applicable to the use of the product, (e.g. provisions for use under certain conditions, etc);
- name and address of the notified laboratory(ies);
- name of, and position held by, the person empowered to sign the declaration on behalf of the manufacturer or his authorised representative.

The above mentioned declaration and certificate shall be presented in the official language or languages of the Member State in which the product is to be used.

The validity of the declaration/certificate shall be verified at least once a year.

### ZA.3 CE Marking and labelling

The manufacturer or his authorised representative established within the EEA is responsible for the affixing of the CE marking. The CE marking symbol to affix shall be in accordance with Directive 93/68/EC and shall be shown on the expanded polystyrene (or when not possible it may be on the accompanying label, the packaging or on the accompanying commercial documents e.g. a delivery note). The following information shall accompany the CE marking symbol:

- identification number of the certification body (only for products under systems 1),
- name or identifying mark and registered address of the manufacturer,
- last two digits of the year in which the marking is affixed,
- number of the EC Certificate of conformity or factory production control certificate (if relevant),
- reference to this European Standard,
- description of the product: generic name, material, dimensions, ... and intended use,
- information on those relevant essential characteristics listed in Table ZA.1:
  - declared values and, where relevant, level or class (including “pass” for pass/fail requirements, where necessary) to declare for each essential characteristic as indicated in “Notes” in Table ZA.1.1 to ZA.1.n,
  - “No performance determined” for characteristics where this is relevant,
  - as an alternative, a standard designation (as defined in Clause 6 of this standard) which shows some or all of the relevant characteristics (where the designation covers only some characteristics, it will need to be supplemented with declared values for other characteristics as above).

The “No performance determined” (NPD) option may not be used where the characteristic is subject to a threshold level. Otherwise, the NPD option may be used when and where the characteristic, for a given intended use, is not subject to regulatory requirements in the Member State of destination.

Figure ZA.1 gives an example of the information to be given on the product, label, packaging and/or commercial documents.

  01234
<b>AnyCo Ltd, PO Box 21, B-1050</b>  <b>07</b>  01234-CPD-00234
<b>EN 14933</b>  Expanded polystyrene, intended to be used in civil engineering applications  EPS-EN 14933- CS(10) 250 –BS350- WL(T) 5 – WD(V) 15 - DLT(2)5-CC(2/1,5/50)100-CLRT(5/2x10 <sup>6</sup> )150-CLR(5/2x10 <sup>6</sup> )150- MU 50 -FTC2  Other mandated characteristics  Reaction to fire  Euroclass E  Continuous glowing combustion: g0  Thermal conductivity $\lambda = 0,036 \text{ w/(m} \cdot \text{K)}$

*CE conformity marking, consisting of the "CE"-symbol given in Directive 93/68/EEC.*

*Identification number of the certification body (for system 1)*

*Name or identifying mark and registered address of the producer*

*Two last digits of the year for affixing CE marking (ITT)*

*Certificate number (where relevant)*

*No. of European Standard*

*Description of product*

*Information on regulated characteristics*

**Figure ZA.1 — Example CE marking information**

In addition to any specific information relating to dangerous substances shown above, the product should also be accompanied, when and where required and in the appropriate form, by documentation listing any other legislation on dangerous substances for which compliance is claimed, together with any information required by that legislation.

NOTE 1 European legislation without national derogations need not be mentioned.

NOTE 2 Affixing the CE marking symbol means, if a product is subject to more than one directive, that it complies with all applicable directives.

## Bibliography

- [1] Struik, L. C. E., *Physical aging in amorphous polymers and other materials*, Elsevier Scientific Publishing Company, 1978



---

---

# BSI — British Standards Institution

BSI is the independent national body responsible for preparing British Standards. It presents the UK view on standards in Europe and at the international level. It is incorporated by Royal Charter.

## Revisions

British Standards are updated by amendment or revision. Users of British Standards should make sure that they possess the latest amendments or editions.

It is the constant aim of BSI to improve the quality of our products and services. We would be grateful if anyone finding an inaccuracy or ambiguity while using this British Standard would inform the Secretary of the technical committee responsible, the identity of which can be found on the inside front cover.  
Tel: +44 (0)20 8996 9000. Fax: +44 (0)20 8996 7400.

BSI offers members an individual updating service called PLUS which ensures that subscribers automatically receive the latest editions of standards.

## Buying standards

Orders for all BSI, international and foreign standards publications should be addressed to Customer Services. Tel: +44 (0)20 8996 9001.  
Fax: +44 (0)20 8996 7001. Email: [orders@bsi-global.com](mailto:orders@bsi-global.com). Standards are also available from the BSI website at <http://www.bsi-global.com>.

In response to orders for international standards, it is BSI policy to supply the BSI implementation of those that have been published as British Standards, unless otherwise requested.

## Information on standards

BSI provides a wide range of information on national, European and international standards through its Library and its Technical Help to Exporters Service. Various BSI electronic information services are also available which give details on all its products and services. Contact the Information Centre.  
Tel: +44 (0)20 8996 7111. Fax: +44 (0)20 8996 7048. Email: [info@bsi-global.com](mailto:info@bsi-global.com).

Subscribing members of BSI are kept up to date with standards developments and receive substantial discounts on the purchase price of standards. For details of these and other benefits contact Membership Administration.  
Tel: +44 (0)20 8996 7002. Fax: +44 (0)20 8996 7001.  
Email: [membership@bsi-global.com](mailto:membership@bsi-global.com).

Information regarding online access to British Standards via British Standards Online can be found at <http://www.bsi-global.com/bsonline>.

Further information about BSI is available on the BSI website at <http://www.bsi-global.com>.

## Copyright

Copyright subsists in all BSI publications. BSI also holds the copyright, in the UK, of the publications of the international standardization bodies. Except as permitted under the Copyright, Designs and Patents Act 1988 no extract may be reproduced, stored in a retrieval system or transmitted in any form or by any means – electronic, photocopying, recording or otherwise – without prior written permission from BSI.

This does not preclude the free use, in the course of implementing the standard, of necessary details such as symbols, and size, type or grade designations. If these details are to be used for any other purpose than implementation then the prior written permission of BSI must be obtained.

Details and advice can be obtained from the Copyright & Licensing Manager.  
Tel: +44 (0)20 8996 7070. Fax: +44 (0)20 8996 7553.  
Email: [copyright@bsi-global.com](mailto:copyright@bsi-global.com).