

Petroleum and natural gas industries — Induction bends, fittings and flanges for pipeline transportation systems —

Part 3: Flanges

The European Standard EN 14870-3:2006 has the status of a
British Standard

ICS 23.040.60; 75.200

National foreword

This British Standard is the official English language version of EN 14870-3:2006.

The UK participation in its preparation was entrusted by Technical Committee PSE/17, Materials and equipment for petroleum, petrochemical and natural gas industries, to Subcommittee PSE/17/2, Transmission pipelines, which has the responsibility to:

- aid enquirers to understand the text;
- present to the responsible international/European committee any enquiries on the interpretation, or proposals for change, and keep UK interests informed;
- monitor related international and European developments and promulgate them in the UK.

A list of organizations represented on this subcommittee can be obtained on request to its secretary.

Cross-references

The British Standards which implement international or European publications referred to in this document may be found in the *BSI Catalogue* under the section entitled “International Standards Correspondence Index”, or by using the “Search” facility of the *BSI Electronic Catalogue* or of British Standards Online.

This publication does not purport to include all the necessary provisions of a contract. Users are responsible for its correct application.

Compliance with a British Standard does not of itself confer immunity from legal obligations.

Summary of pages

This document comprises a front cover, an inside front cover, the EN title page, pages 2 to 23 and a back cover.

The BSI copyright notice displayed in this document indicates when the document was last issued.

This British Standard was published under the authority of the Standards Policy and Strategy Committee on 31 March 2006

© BSI

ISBN 0 580 48001 1

Amendments issued since publication

Amd. No.	Date	Comments

ICS 23.040.60; 75.200

English Version

Petroleum and natural gas industries - Induction bends, fittings
and flanges for pipeline transportation systems - Part 3: Flanges
(ISO 15590-3:2004, modified)

Industries du pétrole et du gaz naturel - Coudes d'induction,
raccords et brides pour systèmes de transport par
conduites - Partie 3 : Brides (ISO 15590-3:2004, modifié)

Erdöl- und Erdgasindustrie - Im Induktionsverfahren
gefertigte Rohrbögen, Fittings und Flansche für
Rohrleitungs-Transportsysteme - Teil 3: Flansche (ISO
15590-3:2004, modifiziert)

This European Standard was approved by CEN on 5 January 2006.

CEN members are bound to comply with the CEN/CENELEC Internal Regulations which stipulate the conditions for giving this European Standard the status of a national standard without any alteration. Up-to-date lists and bibliographical references concerning such national standards may be obtained on application to the Central Secretariat or to any CEN member.

This European Standard exists in three official versions (English, French, German). A version in any other language made by translation under the responsibility of a CEN member into its own language and notified to the Central Secretariat has the same status as the official versions.

CEN members are the national standards bodies of Austria, Belgium, Cyprus, Czech Republic, Denmark, Estonia, Finland, France, Germany, Greece, Hungary, Iceland, Ireland, Italy, Latvia, Lithuania, Luxembourg, Malta, Netherlands, Norway, Poland, Portugal, Romania, Slovakia, Slovenia, Spain, Sweden, Switzerland and United Kingdom.



EUROPEAN COMMITTEE FOR STANDARDIZATION
COMITÉ EUROPÉEN DE NORMALISATION
EUROPÄISCHES KOMITEE FÜR NORMUNG

Management Centre: rue de Stassart, 36 B-1050 Brussels

Contents

Page

Explanatory note.....	3
Foreword.....	4
Introduction	5
1 Scope	7
2 Normative references	7
3 Terms and definitions	9
4 Symbols and abbreviated terms	10
5 Designation of flanges	10
6 Pressure class and design	11
7 Information to be supplied by the purchaser	11
7.1 Principal information.....	11
7.2 Supplementary information	12
8 Manufacturing	12
8.1 Manufacturing procedure specification	12
8.2 Starting material.....	12
8.3 Hubs	12
8.4 Heat treatment.....	13
9 Testing and inspection.....	13
9.1 General requirements.....	13
9.2 Extent of testing and inspection	13
9.3 Chemical composition	14
9.4 Physical testing.....	14
9.5 NDT.....	18
9.6 Dimensions.....	20
9.7 Hydrostatic testing	21
9.8 Weldability	21
9.9 Repair welding	21
10 Documentation.....	21
10.1 Inspection document.....	21
10.2 Manufacturing record book	21
11 Marking	22
Bibliography	23

Explanatory note

ISO 15590-3:2004, developed within ISO/TC 67 SC 2, has been taken over as a European Standard EN 14870-3 (ISO 15590-3:2004, modified).

The scope of ISO/TC 67/SC 2 is pipeline transportation systems for the petroleum and natural gas industries without exclusions. However in CEN, the scopes of CEN/TC 12 and CEN/TC 234 overlapped until 1995. This scope overlap caused problems for the parallel procedure for the above-mentioned items. The conflict in scope was resolved when both the CEN/Technical Committees and the CEN/BT took the following resolution:

Resolution BT 38/1995:

Subject: Revised scope of CEN/TC 12

“BT endorses the conclusions of the coordination meeting between CEN/TC 12 “Materials, equipment and offshore structures for petroleum and natural gas industries” and CEN/TC 234 “Gas supply” and modifies the CEN/TC 12 scope, to read:

“Standardization of the materials, equipment and offshore structures used in drilling, production, refining and the transport by pipelines of petroleum and natural gas, excluding on-land supply systems used by the gas supply industry and those aspects of offshore structures covered by IMO requirement (ISO/TC 8).

The standardization is to be achieved wherever possible by the adoption of ISO Standards.”

Resulting from Resolution BT 38/1995, "**gas supply on land**" has been excluded from the scope of ISO 15590-3:2004 for the European adoption by CEN/TC 12.

Foreword

This European Standard (EN 14870-3:2006) has been prepared by Technical Committee CEN/TC 12 "Materials, equipment and offshore structures for petroleum, petrochemical and natural gas industries", the secretariat of which is held by AFNOR.

This European Standard shall be given the status of a national standard, either by publication of an identical text or by endorsement, at the latest by August 2006, and conflicting national standards shall be withdrawn at the latest by August 2006.

The text of ISO 15590-3 was prepared by Technical Committee ISO/TC 67, *Materials, equipment and offshore structures for petroleum, petrochemical and natural gas industries*, Subcommittee SC 2, *Pipeline transportation systems*.

With respect to ISO 15590-3 the scope of this European Standard excludes on-land supply systems used by the gas supply industry.

Attention is drawn to the possibility that some of the elements of this European Standard may be the subject of patent rights. ISO and CEN shall not be held responsible for identifying any or all such patent rights.

EN 14870 consists of the following parts, under the general title *Petroleum and natural gas industries — Induction bends, fittings and flanges for pipeline transportation systems*:

- *Part 1: Induction bends (ISO 15590-1:2001 modified)*
- *Part 2: Fittings (ISO 15590-2:2003 modified)*
- *Part 3: Flanges (ISO 15590-3:2004 modified)*

The ISO standards listed in Clause 2 "Normative references" correspond to the following European Standards:

ISO 377	Steel and steel products — Location and preparation of samples and test pieces for mechanical testing	EN ISO 377
ISO 2566-1	Steel — Conversion of elongation values — Part 1: Carbon and low alloy steels	EN ISO 2566-1
ISO 6507-1	Metallic materials — Vickers hardness test — Part 1: Test method	EN ISO 6507-1
ISO 13623	Petroleum and natural gas industries — Pipeline transportation systems	EN 14161 (ISO 13623:2000, modified)
ISO 15156-2:2003	Petroleum, petrochemical and natural gas industries — Materials for use in H ₂ S-containing environments in oil and gas production — Part 2: Cracking-resistant carbon and low alloy steels, and the use of cast iron	EN ISO 15156-2:2003

According to the CEN/CENELEC Internal Regulations, the national standards organizations of the following countries are bound to implement this European Standard: Austria, Belgium, Cyprus, Czech Republic, Denmark, Estonia, Finland, France, Germany, Greece, Hungary, Iceland, Ireland, Italy, Latvia, Lithuania, Luxembourg, Malta, Netherlands, Norway, Poland, Portugal, Romania, Slovakia, Slovenia, Spain, Sweden, Switzerland and United Kingdom.

Introduction

Users of this part of EN 14870 should be aware that further or differing requirements may be needed for individual applications. This part of EN 14870 is not intended to inhibit a manufacturer from offering, or the purchaser from accepting, alternative equipment or engineering solutions for the individual application. This can be particularly applicable where there is innovative or developing technology. Where an alternative is offered, the manufacturer should identify any variations from this part of EN 14870 and provide details.

1 Scope

This part of EN 14870 applies to weldneck and blind flanges (full face, raised face, and RTJ groove) as well as anchor, swivel-ring flanges and orifice flanges.

This part of EN 14870 specifies the technical requirements for carbon steel and low-alloy steel forged flanges for use in pipeline transportation systems for the petroleum and natural gas industries as defined in ISO 13623.

This part of EN 14870 designates those categories of flanges that meet the industry's need to match ISO 3183 pipe. These flanges are for normal and low-temperature service and include supplementary requirements where required for sour service.

Materials for, or the attachment of, factory-welded extensions, bolting materials, gaskets, slip-on flanges or flanged fittings are not covered by this part of EN 14870.

This part of EN 14870 is not applicable to integrally cast or forged flanges for valves, pumps or other equipment.

This part of EN 14870 does not cover the selection of the flange category or pressure class. Sizes and pressure classes listed in ISO 7005-1 and applicable to this part of EN 14870 are as follows:

- DN 10 (NPS 1/2) to DN 1500 (NPS 60);
- PN 20 (class 150), PN 50 (class 300), PN 100 (class 600), PN 150 (class 900), PN 250 (class 1500), PN 420 (class 2500).

On-land supply systems used by the gas supply industry are excluded from the scope of this document.

2 Normative references

The following referenced documents are indispensable for the application of this document. For dated references, only the edition cited applies. For undated references, the latest edition of the referenced document (including any amendments) applies.

ISO 148-1, *Metallic material — Charpy pendulum impact test — Part 1: Test method*

ISO 377, *Steel and steel products — Location and preparation of samples and test pieces for mechanical testing*

ISO 783, *Metallic materials — Tensile testing at elevated temperature*

ISO 2566-1, *Steel — Conversion of elongation values — Part 1: Carbon and low alloy steels*

ISO 3183-1, *Petroleum and natural gas industries — Steel pipe for pipelines — Technical delivery conditions — Part 1: Pipes of requirement class A*

ISO 3183-2, *Petroleum and natural gas industries — Steel pipe for pipelines — Technical delivery conditions — Part 2: Pipes of requirement class B*

ISO 3183-3, *Petroleum and natural gas industries — Steel pipe for pipelines — Technical delivery conditions — Part 3: Pipes of requirement class C*

ISO 4885, *Ferrous products — Heat treatments — Vocabulary*

ISO 6507-1:1997, *Metallic materials — Vickers hardness test — Part 1: Test method*

ISO 6892, *Metallic materials — Tensile testing at ambient temperature*

EN 14870-3:2006 (E)

ISO 7005-1:1992, *Metallic flanges — Part 1: Steel flanges*

ISO/TR 7705:1991, *Guidelines for specifying Charpy V-notch impact prescriptions in steel specifications*

ISO 9327-1, *Steel forgings and rolled or forged bars for pressure purposes — Technical delivery conditions — Part 1: General requirements*

ISO 9712, *Non-destructive testing — Qualification and certification of personnel*

ISO 10474:1991, *Steel and steel products — Inspection documents*

ISO 11496, *Seamless and welded steel tubes for pressure purposes — Ultrasonic testing of tube ends for the detection of laminar imperfections*

ISO 12095, *Seamless and welded steel tubes for pressure purposes — Liquid penetrant testing*

ISO 13623, *Petroleum and natural gas industries — Pipeline transportation systems*

ISO 13664, *Seamless and welded steel tubes for pressure purposes — Magnetic particle inspection of the tube ends for the detection of laminar imperfections*

ISO 13665, *Seamless and welded steel tubes for pressure purposes — Magnetic particle inspection of the tube body for the detection of surface imperfections*

ISO 15156-2:2003, *Petroleum and natural gas industries — Materials for use in H₂S-containing environments in oil and gas production — Part 2: Cracking-resistant carbon and low alloy steels, and the use of cast irons*

EN 14870-1:2004, *Petroleum and natural gas industries — Induction bends, fittings and flanges for pipeline transportation systems — Part 1: Induction bends (ISO 15590-1:2001 modified)*

EN 14870-2, *Petroleum and natural gas industries — Induction bends, fittings and flanges for pipeline transportation systems — Part 2: Fittings (ISO 15590-2:2003 modified)*

ASME Boiler and Pressure Vessel Code; Section VIII Division 1, *Rules for Construction of Pressure Vessels*

ASME B16.5, *Pipe Flanges and Flanged Fittings — NPS 1/2 through 24*

ASME B16.36¹⁾, *Orifice Flanges*

ASME B16.47, *Large Diameter Steel Flange — NPS 26 through NPS 60*

ASME B31.3, *Process piping*

ASTM A 370-03a¹⁾, *Standard Test Methods and Definitions for Mechanical Testing of Steel Products*

ASTM E 112-96e3, *Standard Test Methods for Determining Average Grain Size*

MSS SP 44²⁾, *1996 Steel Pipeline Flanges*

¹⁾ American Society for Testing and Materials, 100 Bar Harbor Drive, West Conshohocken, PA 19428-2959, USA

²⁾ Manufacturer's Standardization Society of the Valve and Fittings Industry, 127 Park Street, N.E., Vienna, Virginia 22180, USA

3 Terms and definitions

For the purposes of this document, the terms and definitions given in ISO 4885 and the following apply.

3.1

ANSI rating class

numerical pressure design class defined in ASME B16.5 and used for reference purposes

NOTE The ANSI rating class is designated by the word "Class" followed by a number.

[ISO 14313:1999]^[1]

3.2

by agreement

agreed between manufacturer and purchaser

[ISO 14313:1999]^[1]

3.3

heat

batch of steel prepared in one steel-making operation

[EN 14870-1:2004]

3.4

imperfection

irregularity in the wall or on the surface detectable by methods described in this part of EN 14870

3.5

manufacturing procedure specification

MPS

document which specifies the process control parameters and the acceptance criteria to be applied for all manufacturing, inspection and testing activities performed during flange manufacture

NOTE Adapted from EN 14870-2.

3.6

matching pipe

specified pipe grade and thickness to which the flange will be attached

3.7

pressure class

numerical pressure design class expressed in accordance with either the nominal pressure (PN) class or the ANSI rating class

NOTE In this part of EN 14870, the pressure class is stated by the PN class followed by the ANSI rating class between brackets.

[ISO 14313:1999]^[1]

4 Symbols and abbreviated terms

A_0	original cross-sectional area of the parallel length of a test specimen
CE	carbon equivalent
DN	nominal diameter
HIC	hydrogen-induced cracking
HV	Vickers hardness
ID	inside diameter
L	low-temperature service
LS	low-temperature sour service
MPS	manufacturing procedure specification
MT	magnetic particle testing
N	normal service
NDT	non-destructive testing
NPS	nominal pipe size
NS	normal sour service
PN	nominal pressure
PT	liquid penetrant testing
R_m	tensile strength
RTJ	ring type joint
S	sour service
SMTS	specified minimum tensile strength
SMYS	specified minimum yield strength
SSC	sulfide stress cracking
t	specified wall thickness at the welding ends for flanges
$T_{d\ min}$	minimum design temperature
UT	ultrasonic testing

5 Designation of flanges

Flanges shall be designated as specified in Table 1.

Table 1 — Flange designations

Non-sour service		Sour service	
Temperature, $T_{d\ min}$ °C	Flange designation	Temperature, $T_{d\ min}$ °C	Flange designation
≥ 0	(N)	≥ 0	(NS)
< 0	(L)	< 0	(LS)

Flanges with a minimum design temperature lower than 0 °C shall demonstrate proven notch toughness in accordance with Clause 9.

Flanges intended for sour service shall be so specified by the purchaser and meet the applicable requirements of Clause 9.

6 Pressure class and design

The flange shall be capable of withstanding an internal pressure equal to the working pressure at the temperature range required. Maximum pressures for the various pressure classes against temperature are shown in Table 2.

Table 2 — Maximum pressures as a function of temperature

Temperature °C	PN											
	20		50		100		150		250		420	
	Class											
	150		300		600		900		1 500		2 500	
	MPa	(bar)	MPa	(bar)	MPa	(bar)	MPa	(bar)	MPa	(bar)	MPa	(bar)
–30 to 120	1,96	(19,6)	5,11	(51,1)	10,2	(102)	15,3	(153)	25,5	(255)	42,6	(426)
150	1,9	(19)	4,93	(49,3)	9,86	(98,6)	14,8	(148)	22,6	(226)	37,7	(377)
175	1,83	(18,3)	4,75	(47,5)	9,51	(95,1)	14,3	(143)	22,2	(222)	34,1	(341)
200	1,76	(17,6)	4,59	(45,9)	9,17	(91,7)	13,8	(138)	21,9	(219)	36,5	(365)
250	1,7	(17)	4,41	(44,1)	8,86	(88,6)	13,3	(133)	22,5	(225)	35,5	(355)

For any temperature below 30 °C, the rating shall be no greater than the rating shown for –30 °C.
 For intermediate temperatures, linear interpolation should be used.
 Ratings of flanges for temperatures greater than those given shall be by agreement.

If there are any deviations from the flange dimensions specified in ISO 7005-1, pressure-containment calculations shall be made in accordance with an agreed pressure-vessel design standard such as ASME Section VIII, Division 1.

The design calculations shall be available for review.

For pipeline applications, the design criteria shall be in accordance with ISO 7005-1:1992, Annex F.

NOTE External loads or moments are not covered by this part of EN 14870. However, swivels and anchor flanges can experience external loads and can be designed using the equivalent pressure method.

7 Information to be supplied by the purchaser

7.1 Principal information

The following information shall be provided:

- a) flange designation, size and class;

EN 14870-3:2006 (E)

- b) quantity of flanges;
- c) material grade;
- d) wall thickness, specified minimum yield strength and bore size for the matching pipe;
- e) flange facing (e.g. raised face, RTJ).

7.2 Supplementary information

If applicable, the following supplementary information shall be provided:

- a) minimum and maximum design temperatures;
- b) special dimensional requirements;
- c) requirements for supplementary inspection and testing;
- d) pipeline-design standard or design factors, if different from ISO 13623 (e.g. anchor and swivel flanges);
- e) pipeline operating conditions;
- f) mechanical property requirements at the maximum design temperature;
- g) hold-points for witness and approval;
- h) marking requirements if different from this part of EN 14870;
- i) packaging and shipping instructions;
- j) third-party inspection organization.

8 Manufacturing

8.1 Manufacturing procedure specification

Flanges shall be manufactured in accordance with a documented MPS, which includes all of the necessary steps to be taken in the manufacture of flanges to this part of EN 14870. The MPS shall address the information listed in Clause 7 as applicable. Additional details may be required in the MPS prior to the commencement of manufacturing.

8.2 Starting material

Forgings shall meet the requirements of ISO 9327-1. The starting material for forged flanges shall be ingot, bloom, billet, slab, plate (for blind flanges only) or bar and shall be fully killed steel (see ISO 7005-1:1992, Table D.3). Flanges shall not be machined from bars.

The material designation shall be consistent with ISO 3183-1, ISO 3183-2 and ISO 3183-3.

8.3 Hubs

Pipeline applications shall be in accordance with ISO 7005-1:1992, 2.4.5. Hubs shall be single slope or dual slope in accordance with ISO 7005-1.

8.4 Heat treatment

Heat-treatment vocabulary shall be in accordance with ISO 4885.

Forged flanges shall be normalized, normalized and tempered, or quenched and tempered after forming. The heat treatment shall be performed in accordance with a documented procedure. A record (heat treat chart) shall be maintained of each heat treatment and shall be included in the inspection document, if specified.

The tolerances on soaking temperature shall be ± 15 °C and on soaking time ± 20 %.

9 Testing and inspection

9.1 General requirements

Testing and inspection shall be carried out on flange forgings after final heat treatment. If the pipeline installation techniques will require post-weld heat treatment of the flange, additional testing can be required to demonstrate that the mechanical properties of the flange are achieved after post-weld heat treatment. Details of the post-weld heat treatment cycle to be used during pipeline installation shall be specified. The test requirements and acceptance criteria shall be by agreement.

9.2 Extent of testing and inspection

Mechanical testing samples shall consist of a prolongation, or sacrificial forging. By agreement, a separately forged test bar of the same heat as for the final forgings shall be supplied. This test bar shall receive the same approximate working and shall be heat-treated with the flange forgings it represents.

The extent of testing and inspection to be performed shall be as stated in Table 3 for each heat. Locations for the test pieces to be taken from a flange forging shall be in accordance with ASTM A 370, $1/4 t \times t$, or as established by agreement.

Table 3 — Number of tests for destructive physical testing

Type of test	Number and frequency of testing
chemical composition	one per heat
tensile – base metal	one per heat
impact – base metal	one set per heat, if applicable
through-thickness hardness	by agreement for NS and LS
surface hardness	by agreement
metallography	one per heat for NS and LS
HIC	by agreement
SSC	by agreement
NDT	by agreement

9.3 Chemical composition

Ladle analysis shall have values as specified in Table 4. A product analysis shall be made for each heat of steel and shall comply with the values in Table 4.

Table 4 — Maximum permitted element concentrations in alloys for product analyses by category, mass fraction, %

Element	Concentration in alloys % mass fraction	
	Non-sour service (designations N and L)	Sour service (designations NS and LS)
C	0,20	0,18
Mn	1,60	1,30
Si	0,40	0,40
P	0,025	0,025
S	0,010	0,003 ^a
V	0,10	0,10
Nb	0,05	0,05
Ti	0,04	0,04
Cr	0,25	0,25
Mo	0,10	0,10
Ni	0,50	0,50
Cu	0,35	0,35
Al ^d	0,06	0,05
N ^d	0,010 to 0,030	0,012
B	0,001	0,000 5 ^b
Ca	0,006	0,006 ^a
CE ^c	0,45	0,43

^a The Ca:S ratio shall be a minimum of 1 for S in the range 0,0015 % to 0,003 %.

^b Boron shall not be intentionally added. Boron product analysis is not always accurate below 0,001 % (see ASTM E415^[2]).

^c Carbon equivalent, calculated as follows: $CE = C + \frac{Mn}{6} + \frac{Cr + Mo + V}{5} + \frac{Ni + Cu}{15}$.

^d The total Al:N ratio shall be $\geq 2:1$.

9.4 Physical testing

9.4.1 Preparation of test pieces

Test pieces shall be prepared in accordance with ISO 377. If thermal cutting has been used to remove samples, the full extent of the heat-affected region shall be removed during the preparation of the test pieces.

9.4.2 Tensile testing

9.4.2.1 Test pieces

Orientation of the base-metal test pieces shall be longitudinal to the major axis of the flange in the weldneck hub. The largest possible round test specimen shall be obtained (see Figure 1). Tensile testing representing blind or blank flanges may be taken from forged test bars that have received approximately the same amount of working as the blind or blank flanges they represent.

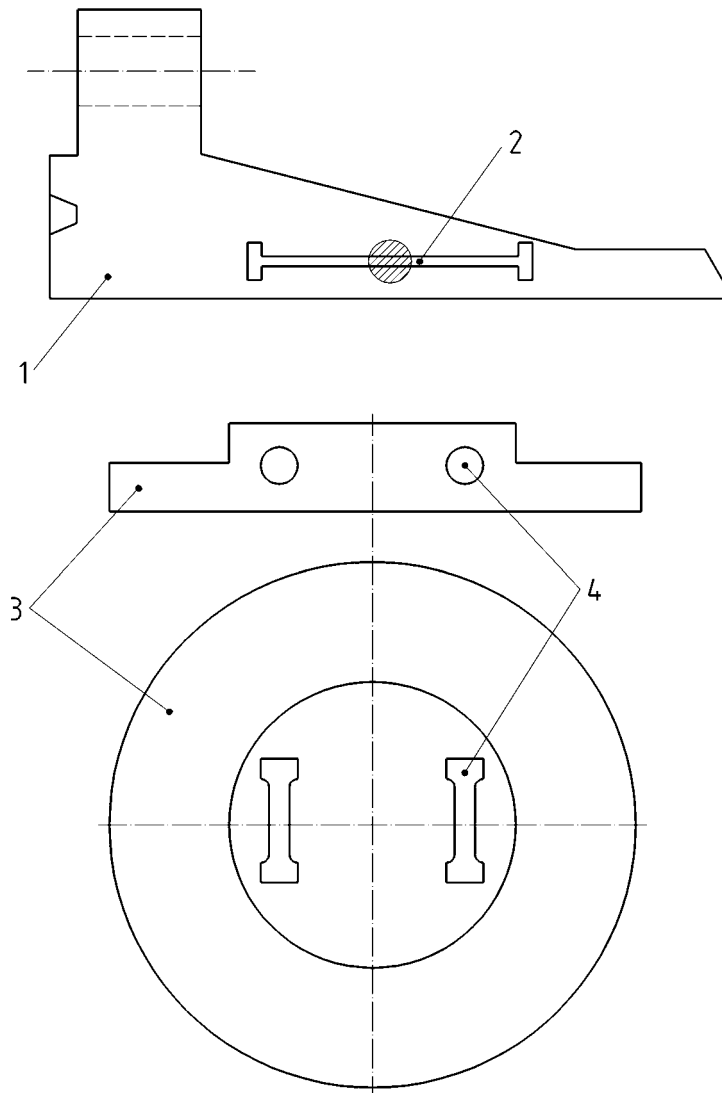

Key

- 1 welding neck flange
- 2 longitudinal tensile specimens
- 3 blind flange
- 4 transverse tensile specimens

Figure 1 — Location of tensile test specimens

9.4.2.2 Test method

Tensile testing at ambient temperature shall be carried out in accordance with ISO 6892. If specified, tensile testing at elevated temperatures shall be carried out in accordance with ISO 783.

The frequency of all testing shall meet the requirements of Table 3.

For tensile tests, percentage elongation after fracture shall be determined. The percentage elongation after fracture shall be reported with reference to a gauge length of $5,65\sqrt{A_0}$. If other gauge lengths are used, the elongation referred to a gauge length of $5,65\sqrt{A_0}$ shall be determined in accordance with ISO 2566-1.

9.4.2.3 Requirements

The material used shall meet the requirements of Table 6. The allowance for pipeline applications listed in ISO 7005-1:1992, 2.4.5, can be used.

9.4.3 Charpy V-notch impact tests

9.4.3.1 Test pieces

Charpy V-notch test pieces shall be prepared in accordance with ISO 148-1 with the axis of the notch perpendicular to the flange surface.

The orientation and size of the test pieces shall be as follows:

- a) transverse with the greatest possible width between 10 mm and 5 mm (see example in Figure 2);
- b) if transverse test pieces with a minimum width of 5 mm are not possible, longitudinal test pieces with the greatest possible width between 10 mm and 5 mm shall be used;
- c) Charpy V-notch impact testing shall be in accordance with ISO 148-1 with the additional requirement to report % shear area at the fracture surface;
- d) each set of impact tests shall consist of three adjacent test pieces.

The impact test temperature shall be established in accordance with Table 5.

Transverse Charpy specimens shall be notched through-thickness. The actual location shall be that nearest to the welded end from which 10 mm × 10 mm Charpy specimens can be taken.

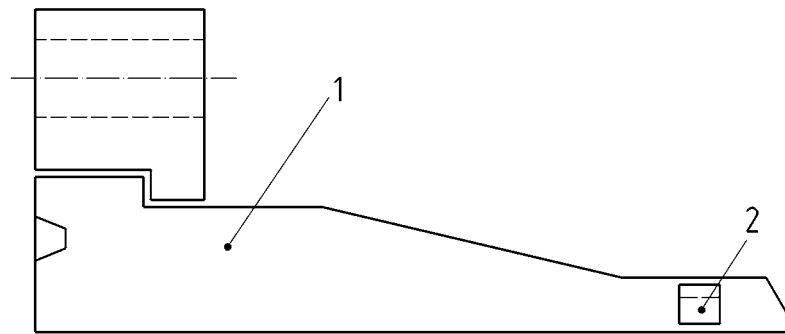

Key

- 1 swivel ring flange
- 2 specimen location

Figure 2 — Location of Charpy V-notch testing specimens (example for a swivel ring flange)

Table 5 — Maximum Charpy V-notch test temperature by category

Nominal wall thickness, t mm	$T_{d \min}$ for N and NS °C	$T_{d \min}$ for L and LS °C
≤ 20	≤ 0	≤ -10
$> 20, \leq 25$	≤ 0	≤ -20
> 25	≤ 0	by agreement

9.4.3.2 Requirements

Charpy V-notch tests shall be carried out in accordance with ISO 148-1.

The minimum average absorbed energy, in joules, of the Charpy V-notch impact tests in the transverse direction shall meet the requirements in Table 6.

Table 6 — Mechanical properties by steel grade

Steel grade SMYS	SMTS	Elongation	Minimum average Charpy V-notch value	Minimum Charpy V-notch value
N/mm ²	N/mm ²	%	J	J
245	415	22	27	22
290	415	21	30	24
360	460	20	36	30
415	520	18	42	35
450	535	18	45	38
485	570	18	50	40
555	625	18	56	45

The tensile requirements for intermediate grades shall be obtained by interpolation between those specified for standard grades.

The minimum average and individual Charpy V-notch values when testing test pieces taken in the longitudinal direction shall be at least 1,5 times the values stated for transverse test pieces.

EN 14870-3:2006 (E)

If specified, the minimum average shear area shall be 50 % of the fracture surface for any set of tests and all individual test pieces shall exhibit at least 40 % fibrous shear.

For subsidiary test pieces, the minimum required absorbed energy values shall be adjusted in accordance with ISO TR 7705:1991, Clause 6.

9.4.4 Hardness requirements

Through-thickness hardness testing shall be performed using the Vickers method in accordance with ISO 6507-1:1997, method HV₁₀ (i.e. with a test force of 98,07 N).

Hardness indent locations for flanges shall be by agreement.

No hardness reading shall exceed 250 HV₁₀ for sour-service flange forgings and 300 HV₁₀ for non-sour service-flange forgings.

9.4.5 Metallographic examination

9.4.5.1 Method

Grain-size shall be determined in accordance with ASTM E 112.

9.4.5.2 Requirements

The photomicrographs shall demonstrate that the manufacturing process and any subsequent heat treatment have produced a consistent microstructure without separations in the base metal.

Forged flanges shall have an average grain-size number of 7 or finer.

9.4.6 HIC tests

If HIC testing is specified, the test procedures and acceptance criteria shall be in accordance with ISO 15156-2.

NOTE This test is not normally specified.

9.4.7 SSC tests

If SSC testing is specified, test procedures and acceptance criteria shall be in accordance with ISO 15156-2.

9.5 NDT

9.5.1 NDT personnel and procedures

NDT shall always be performed after final heat treatment.

All NDT shall be conducted in accordance with documented procedures.

If specified, NDT procedures shall be decided by agreement before commencement of flange manufacture.

All NDT personnel shall be qualified and certified in accordance with ISO 9712 to the appropriate level of competence. The minimum level of competence for UT shall be NDT level 2.

NOTE The pressure-vessel or similar industry would be an acceptable sector for the specific examination of ISO 9712.

9.5.2 Forging preparation

All NDT for acceptance of forgings in accordance with the requirements of this part of EN 14870 shall be performed after final heat treatment of forgings, except that the surfaces of forgings shall be finished so that surface imperfections can be detected by visual inspection.

The surface to be examined and all adjacent areas within 25 mm shall be dry and free from all dirt, grease, lint, scale, welding flux and spatter, oil or other extraneous matter that could interfere with the non-destructive examination.

9.5.3 Visual inspection

Forged flanges shall be free from dents with sharp bottom gouges or dents exceeding 3 mm in depth.

The depth of a gouge or dent shall be measured as the maximum distance between the contour of the gouge or dent and the normal flange contour.

9.5.4 MT/PT inspection

9.5.4.1 Method

The weld-end of flanges shall be inspected by MT in accordance with ISO 13664 for the presence of laminar imperfections. By agreement, PT or UT inspection may be carried out instead of MT. In case of UT inspection, the probe shall be placed on the inner surface of the flange.

All other areas of the flange shall be MT-inspected after all heat treatment has been completed. Each flange shall be inspected by magnetic particle testing in accordance with ISO 13665 or by liquid penetrant testing in accordance with ISO 12095.

9.5.4.2 Requirements

A percentage test shall be by agreement, provided a minimum of 10 % of the batch is tested.

Laminar or linear imperfections equal to or greater than 2 mm in the circumferential direction and with an area exceeding 100 mm² shall not be permitted.

If any unacceptable imperfection is found on the test sample, then 100 % testing shall be carried out on the lot.

Imperfections not classified as defects are permitted to remain in the flange without repair. Localized grinding, however, is permitted.

All dressable surface defects shall be dressed out by grinding. Grinding shall be carried out in such a way that the dressed area blends in smoothly with the contour of the flange. Complete removal of defects shall be verified by local visual inspection aided, if necessary, by suitable NDT methods.

9.5.5 UT inspection

9.5.5.1 Method

The final 50 mm of each end of the flange shall be UT-inspected for the detection of laminar imperfections in accordance with ISO 11496. Ultrasonic inspection for the detection of longitudinal and/or transverse imperfections shall be performed after all heat treatment has been completed.

The reference standard shall contain notches for longitudinal imperfections and radially drilled holes for transverse imperfections.

EN 14870-3:2006 (E)

For the purpose of determining the extent of suspect areas, adjacent suspect areas separated by less than twice the minor axis of the imperfection shall be considered as a single imperfection.

9.5.5.2 Requirements

The frequency of testing shall be established by agreement.

Laminar imperfections equal to or greater than 6 mm in the circumferential direction and with an area exceeding 100 mm² shall not be permitted.

9.6 Dimensions

9.6.1 Flange dimensions

Dimensions of weldneck flanges shall be in accordance with ISO 7005-1 and shall be compatible with ASME B16.5, B16.36, B16.47 and MSS SP 44.

Dimensions of orifice flanges shall be in accordance with ASME B16.36.

Anchor flanges shall be designed in accordance with ISO 13623 or ASME B31.3.

Swivel-ring flanges shall be designed and calculations shall be made in accordance with an agreed pressure vessel design standard such as ASME Section VIII, Division 1. Swivel-ring flanges shall be suitable to bolt to existing ISO 7005-1 flanges and shall be compatible with ASME B16.5, B16.36, B16.47 and MSS SP 44. Swivel-ring flanges should have RTJ-groove-sealing faces.

9.6.2 Tolerances

Tolerances shall be in accordance with ISO 7005-1.

9.6.3 Flange-face finish

Flange-face finish shall be in accordance with ISO 7005-1 and Table 7.

Table 7 — Permissible imperfections in raised face flange finish

Pipe size		Maximum radial projection of imperfections which are no deeper than the bottom of the serrations ^a mm	Maximum depth and radial projection ^b of imperfections which are deeper than the bottom of the serrations mm
DN mm	NPS in		
15 to 80	(1/2 to 3)	3	1,5
100 to 150	(4 to 6)	6	3
200 to 350	(8 to 14)	8	4
400	(16)	10	5
450 to 900	(18 to 36)	12	6
950 to 1 200	(38 to 48)	13	6,5
1 250 to 1 500	(50 to 60)	16	8

a Imperfections less than half the depth of the serrations shall not be cause for rejection.

b A radial projection shall be measured by the difference between an inner and an outer radius encompassing the imperfection where the radius is struck from the centerline of the bore.

9.7 Hydrostatic testing

Hydrostatic testing of flanges is not required unless otherwise specified.

Flanged joints may be subjected to system hydrostatic tests at a pressure limited to 1,5 times the 40 °C rating (PN class) rounded off to the next higher one (1) bar. Testing at any higher pressure is by agreement.

9.8 Weldability

The steel used to manufacture flanges shall be suitable to weld to other flanges, pipe manufactured to ISO 3183-2 and ISO 3183-3 and induction bends and fittings manufactured to EN 14870-1 and EN 14870-2.

Proof of field weldability may be required by agreement.

9.9 Repair welding

Weld repair of flanges shall be performed only by agreement. Repair welding shall be performed in accordance with specified standards.

NOTE Welding of swivel-ring flange retaining rings is outside the scope of this document.

10 Documentation

10.1 Inspection document

The required ISO 10474 designation of the inspection document and any specific requirements for format and content of the document shall be specified.

10.2 Manufacturing record book

If required, a manufacturing record book shall be prepared, assembled into sections, indexed, including the following as a minimum:

- flange MPS;
- list of flanges produced, identification and heat numbers;
- original steel maker's or forger's certificates;
- official certificates of mechanical test results, stamped and signed as-approved;
- records of heat treatments, heat treat charts;
- NDT results and certificates;
- dimensional inspection reports;
- masses;
- other documents as required (e.g. inspection documents).

11 Marking

Each flange shall be identified with the marking requirements in accordance with ISO 7005-1:1992, 2.8.

In addition to the above-defined markings, the heat reference shall be die-stamped on the external surface, using low-stress 10 mm rounded or interrupted dot stamps. Smaller stamps may be required on small sized flanges due to space limitations.

Identification markings shall not be stencilled or painted on the weld preparation or the raised face or RTJ groove.

Each flange shall be marked as a minimum with the following information:

- purchase order and item number;
- applied International Standard, i.e. EN 14870-3 (ISO 15590-3:2004, modified);
- specification and material grade of forging;
- heat number;
- DN and NPS;
- wall thickness, pipe schedule and bore;
- manufacturer's name or trade mark;
- flange designation, as defined in Clause 5;
- design pressure or class;
- temperature of Charpy V-notch testing.

EXAMPLE 1 -20 °C = M20C.

EXAMPLE 2 +10 °C = P10C.

Bibliography

- [1] ISO 14313:1999, *Petroleum and natural gas industries — Pipeline transportation systems — Pipeline valves*
- [2] ASTM E 415-99a, *Standard Test Method for Optical Emission Vacuum Spectrometric Analysis of Carbon and Low-Alloy Steel*

BSI — British Standards Institution

BSI is the independent national body responsible for preparing British Standards. It presents the UK view on standards in Europe and at the international level. It is incorporated by Royal Charter.

Revisions

British Standards are updated by amendment or revision. Users of British Standards should make sure that they possess the latest amendments or editions.

It is the constant aim of BSI to improve the quality of our products and services. We would be grateful if anyone finding an inaccuracy or ambiguity while using this British Standard would inform the Secretary of the technical committee responsible, the identity of which can be found on the inside front cover. Tel: +44 (0)20 8996 9000. Fax: +44 (0)20 8996 7400.

BSI offers members an individual updating service called PLUS which ensures that subscribers automatically receive the latest editions of standards.

Buying standards

Orders for all BSI, international and foreign standards publications should be addressed to Customer Services. Tel: +44 (0)20 8996 9001. Fax: +44 (0)20 8996 7001. Email: orders@bsi-global.com. Standards are also available from the BSI website at <http://www.bsi-global.com>.

In response to orders for international standards, it is BSI policy to supply the BSI implementation of those that have been published as British Standards, unless otherwise requested.

Information on standards

BSI provides a wide range of information on national, European and international standards through its Library and its Technical Help to Exporters Service. Various BSI electronic information services are also available which give details on all its products and services. Contact the Information Centre. Tel: +44 (0)20 8996 7111. Fax: +44 (0)20 8996 7048. Email: info@bsi-global.com.

Subscribing members of BSI are kept up to date with standards developments and receive substantial discounts on the purchase price of standards. For details of these and other benefits contact Membership Administration. Tel: +44 (0)20 8996 7002. Fax: +44 (0)20 8996 7001. Email: membership@bsi-global.com.

Information regarding online access to British Standards via British Standards Online can be found at <http://www.bsi-global.com/bsonline>.

Further information about BSI is available on the BSI website at <http://www.bsi-global.com>.

Copyright

Copyright subsists in all BSI publications. BSI also holds the copyright, in the UK, of the publications of the international standardization bodies. Except as permitted under the Copyright, Designs and Patents Act 1988 no extract may be reproduced, stored in a retrieval system or transmitted in any form or by any means – electronic, photocopying, recording or otherwise – without prior written permission from BSI.

This does not preclude the free use, in the course of implementing the standard, of necessary details such as symbols, and size, type or grade designations. If these details are to be used for any other purpose than implementation then the prior written permission of BSI must be obtained.

Details and advice can be obtained from the Copyright & Licensing Manager. Tel: +44 (0)20 8996 7070. Fax: +44 (0)20 8996 7553. Email: copyright@bsi-global.com.