

Precast concrete products — Stairs

The European Standard EN 14843:2007 has the status of a
British Standard

ICS 91.060.30; 91.100.30

National foreword

This British Standard was published by BSI. It is the UK implementation of EN 14843:2007.

The UK participation in its preparation was entrusted to Technical Committee B/524, Precast concrete products.

A list of organizations represented on this committee can be obtained on request to its secretary.

EN 14843 is a candidate “harmonized” European standard and fully takes into account the requirements of the European Commission mandate M/100, Products related to precast concrete, given under the EU Construction Products Directive (89/106/EEC), and is intended to lead to CE marking. The date of applicability of EN 14843 as a harmonized European Standard, i.e. the date after which this standard may be used for CE marking purposes, is subject to an announcement in the Official Journal of the European Communities.

The Commission in consultation with Member States has agreed a transition period for the co-existence of harmonized European Standards and their corresponding national standard(s). It is intended that this period will comprise a period, usually nine months, after the date of availability of the European Standard, during which any required changes to national regulations are to be made, followed by a further period, usually of 12 months, for the implementation of CE marking. At the end of this co-existence period, the national standard (s) will be withdrawn.

EN 14843 is the subject of transitional arrangements agreed under the Commission mandate. In the UK, there are no corresponding national standards.

This publication does not purport to include all the necessary provisions of a contract. Users are responsible for its correct application.

Compliance with a British Standard cannot confer immunity from legal obligations.

This British Standard was published under the authority of the Standards Policy and Strategy Committee on 29 June 2007

© BSI 2007

ISBN 978 0 580 52929 0

Amendments issued since publication

Amd. No.	Date	Comments

ICS 91.100.30

English Version

Precast concrete products - Stairs

Produits préfabriqués en béton - Escaliers

Betonfertigteile - Treppen

This European Standard was approved by CEN on 17 February 2007.

CEN members are bound to comply with the CEN/CENELEC Internal Regulations which stipulate the conditions for giving this European Standard the status of a national standard without any alteration. Up-to-date lists and bibliographical references concerning such national standards may be obtained on application to the CEN Management Centre or to any CEN member.

This European Standard exists in three official versions (English, French, German). A version in any other language made by translation under the responsibility of a CEN member into its own language and notified to the CEN Management Centre has the same status as the official versions.

CEN members are the national standards bodies of Austria, Belgium, Bulgaria, Cyprus, Czech Republic, Denmark, Estonia, Finland, France, Germany, Greece, Hungary, Iceland, Ireland, Italy, Latvia, Lithuania, Luxembourg, Malta, Netherlands, Norway, Poland, Portugal, Romania, Slovakia, Slovenia, Spain, Sweden, Switzerland and United Kingdom.



EUROPEAN COMMITTEE FOR STANDARDIZATION
COMITÉ EUROPÉEN DE NORMALISATION
EUROPÄISCHES KOMITEE FÜR NORMUNG

Management Centre: rue de Stassart, 36 B-1050 Brussels

Contents

Page

The numbering of clauses is strictly related to EN 13369:2004: *Common rules for precast concrete products*, at least for the first three digits. When a clause of EN 13369:2004 is not relevant or included in a more general reference of this standard, its number is omitted and this may result in a gap in numbering.

Introduction	6
1 Scope	7
2 Normative references	7
3 Terms and definitions	8
3.1 General	8
4 Requirements	8
4.1 Material requirements	8
4.2 Production requirements	8
4.3 Finished product requirements	8
4.3.1 Geometrical properties	8
4.3.2 Surface characteristics	9
4.3.3 Mechanical resistance	9
4.3.4 Resistance and reaction to fire	10
4.3.5 Acoustic properties	10
4.3.6 Thermal properties	10
4.3.7 Durability	10
4.3.8 Other requirements	10
4.3.9 Detailing	10
5 Test methods	11
5.1 Tests on concrete	11
5.2 Measuring of dimensions and surface characteristics	11
5.3 Weight of the product	11
6 Evaluation of conformity	11
7 Marking	12
8 Technical documentation	12
Annex A (informative) Stairs — Terms and definitions	13
Annex B (informative) Test Method	20
B.1 Objectives	20
B.2 Specification and selection of specimens	20
B.2.1 Identification of product group	20
B.2.2 Design of test specimens	20
Annex Y (Informative) Choice of CE marking method	25
Y.1 Method 1	25
Y.2 Method 2	25
Y.3 Method 3	25
Annex ZA (informative) Clauses of this European Standard addressing the provisions of the EU Constructions Product Directive	26
ZA.1 Scope and relevant characteristics	26
ZA.2 Procedure for attestation of conformity of stairs	28
ZA.2.1 System of attestation of conformity	28
ZA.2.2 EC Certificate and Declaration of conformity	29
ZA.3 CE marking and labelling	30

ZA.3.1 General 30
ZA.3.2 Declaration of geometrical data and material properties..... 32
ZA.3.3 Declaration of product properties 33
ZA.3.4 Declaration of compliance with a given design specification 35
Bibliography..... 38

Foreword

This document (EN 14843:2007) has been prepared by Technical Committee CEN/TC 229 "Precast concrete products", the secretariat of which is held by AFNOR and was examined by and agreed with a joint working party appointed by the Liaison Group CEN/TC 229-TC250, particularly for its compatibility with structural Eurocodes.

This European Standard shall be given the status of a national standard, either by publication of an identical text or by endorsement, at the latest by October 2007, and conflicting national standards shall be withdrawn at the latest by January 2009.

This document has been prepared under a mandate given to CEN by the European Commission and the European Free Trade Association, and supports essential requirements of EU Construction Products Directive(s) (89/106/EEC).

For relationship with EU Directive(s), see informative Annex ZA, which is an integral part of this document.

This document is one of a series of product standards for precast concrete products.

For common aspects reference is made to EN 13369:2004: *Common rules for precast concrete products*, from which also the relevant requirements of the EN 206-1: *Concrete — Part 1: Specification, performance, production and conformity* are taken.

The references to EN 13369:2004 by CEN/TC 229 product standards are intended to make them homogeneous and to avoid repetitions of similar requirements.

Eurocodes are taken as a common reference for design aspects. The installation of some structural precast concrete products is dealt with by ENV 13670-1: *Execution of concrete structures — Part 1: Common rules*, which has at the moment the status of a European Prestandard. In all countries it can be accompanied by alternatives for national application and it should not be treated as a European Standard.

The programme of standards for structural precast concrete products comprises the following standards, in some cases consisting of several parts :

EN 1168, *Precast concrete products — Hollow core slabs*.

EN 12794, *Precast concrete products — Foundation piles*.

EN 12843, *Precast concrete products — Masts and poles*.

EN 13224, *Precast concrete products — Ribbed floor elements*.

EN 13225, *Precast concrete products — Linear structural elements*.

EN 13693, *Precast concrete products — Special roof elements*.

EN 13747, *Precast concrete products — Floor plates for floor systems*.

EN 13978, *Precast concrete products — Precast concrete garages*.

EN 14843, *Precast concrete products — Stairs*.

EN 14844, *Precast concrete products — Box culverts*.

EN 14991, *Precast concrete products — Foundation elements.*

EN 14992, *Precast concrete products — Wall elements.*

prEN 15037, *Precast concrete products - Beam-and-block floor systems.*

EN 15050, *Precast concrete products — Bridge elements.*

prEN 15258, *Precast concrete products — Retaining wall elements.*

This standard defines in Annex ZA the application methods of CE marking to products designed using the relevant EN Eurocodes (EN 1992-1-1 and EN 1992-1-2). Where, in default of applicability conditions of EN Eurocodes to the works of destination, design Provisions other than EN Eurocodes are used for mechanical strength and/or fire resistance, the conditions to affix CE marking to the product are described in ZA.3.4.

According to the CEN/CENELEC Internal Regulations, the national standards organizations of the following countries are bound to implement this European Standard: Austria, Belgium, Bulgaria, Cyprus, Czech Republic, Denmark, Estonia, Finland, France, Germany, Greece, Hungary, Iceland, Ireland, Italy, Latvia, Lithuania, Luxembourg, Malta, Netherlands, Norway, Poland, Portugal, Romania, Slovakia, Slovenia, Spain, Sweden, Switzerland and United Kingdom.

Introduction

The evaluation of conformity given in this standard refers to precast concrete elements which are supplied to the market and covers all the production operations carried out in the factory.

The documentation accompanying a manufactured component will refer to the clauses of this standard with which it complies.

1 Scope

This standard gives specifications for materials, production, properties, requirements and methods of testing for precast concrete monolithic stairs, and for precast concrete elements (e.g. individual steps) used to make reinforced and/or prestressed concrete stairs.

This standard is applicable to structural stairs for indoor or outdoor use.

This standard covers precast concrete stairs and associated landings of monolithic design or constructed from individual steps supported by beams or columns. Supporting elements may include in situ concrete.

This standard covers terminology, performance criteria, verification methods, tolerances, relevant physical properties, special test methods and specific aspects of transport, erection and connection.

Geometrical properties related to functionality of stairs are not covered by this standard and can be found in National regulations or local practice.

Precast concrete stairs are classified into two main product families :

- monolithic stairs constructed from precast concrete components consisting of flights, landings or a combination of these. They may include vertical supporting elements ;
- stairs constructed from individual steps, whether load bearing or not, assembled on site with, for example, carriages or a central column.

Their shape may be straight or winding.

Stairs may incorporate parapets (on one or both sides) and landings.

Stairs may have simple bearings (e.g. on corbels, walls or beams), bolted connections or they may be connected with reinforcement and in situ concrete.

The surfaces of the precast elements may be exposed or covered by finishes.

2 Normative references

The following referenced documents are indispensable for the application of this document. For dated references, only the edition cited applies. For undated references, the latest edition of the referenced document (including any amendments) applies.

EN 1992-1-1:2004, *Eurocode 2: Design of concrete structures — Part 1-1: General rules and rules for buildings*

EN 13369: 2004, *Common rules for precast concrete products*

3 Terms and definitions

3.1 General

Subclauses 3.1 and J.4 of EN 13369:2004 shall apply.

Terms and definitions for stairs are given in Annex A (informative).

4 Requirements

4.1 Material requirements

Subclause 4.1 of EN 13369:2004 shall apply.

4.2 Production requirements

Subclause 4.2 of EN 13369:2004 shall apply.

The concrete shall have a minimum class of C30/37 for reinforced or prestressed concrete stairs.

4.3 Finished product requirements

4.3.1 Geometrical properties

4.3.1.1 Production tolerances

Unless stricter tolerances are given in the project specification, subclause 4.3.1.1 of EN 13369:2004 shall apply except for the amendments given in Table 1 below.

**Table 1 — Amendment to EN 13369:2004, Table 4
Permitted deviations of cross-sections for structural elements**

Target dimension of the cross-section in the direction to be checked	ΔL^a (mm)	Δc^b (mm)
$L \leq 150$ mm	+ 10 - 5	± 5
$L \geq 400$ mm	± 15	+ 15 - 10
Linear interpolation for Intermediate values.		
<p>^a The difference between two consecutive rises shall not exceed 6 mm.</p> <p>^b The minimum concrete cover defined in 4.3.7 shall take into account the depth of any concrete removed by a finishing process. The positioning of reinforcement shall ensure that the minimum cover defined in 4.3.7 is achieved.</p> <p>NOTE 1 ΔL and the positive values for Δc (upper permitted deviation) are given to ensure that deviations in cross-sectional dimensions and in the position of the reinforcement do not exceed values covered by the relevant safety factors in the Eurocodes.</p> <p>NOTE 2 The negative values for Δc (lower permitted deviation) are given for durability purposes.</p>		

4.3.1.2 Minimum nominal dimensions

The minimum nominal dimensions of Table 2 shall apply.

Table 2 — Minimum nominal dimensions (mm)

Dimension	Minimum dimension
Thickness of a step or landing	45
Thickness of a wall	80
Thickness of a parapet	60
Wall thickness of a hollow element	45
Plan dimensions of a column	120

In case of 45 mm of thickness, special care shall be paid to the correct positioning of reinforcement.

4.3.2 Surface characteristics

Subclause 4.3.2 of EN 13369:2004 shall apply.

The tolerances for surface characteristics listed in Table 3 shall be permitted for precast concrete stair components.

Table 3 — Permitted deviations for surface characteristics (sizes in mm)

L = length of the reference ruler ^a $\Delta d = d_1 - d_2$	$\Delta d \leq (2 + L / 500)$
^a See 5.2	

NOTE A client may inform the producer that specific surfaces are intended to be finished with paint or a thin coating.

4.3.3 Mechanical resistance

4.3.3.1 General

Subclause 4.3.3.1 of EN 13369:2004 shall apply.

4.3.3.2 Verification by calculation

Subclause 4.3.3.2 of EN 13369:2004 shall apply.

Both static and dynamic loading should be considered.

NOTE 1 For steps less than 80 mm thick or independent steps, the dynamic coefficient may be defined in National regulations or other rules valid in the place of use of the product.

NOTE 2 For accidental actions and robustness requirements see National regulation.

4.3.3.3 Verification by calculation aided by testing

Subclause 4.3.3.3 of EN 13369:2004 shall apply.

The test methods recommended in Annex B may be used to support verification by calculation.

4.3.4 Resistance and reaction to fire

4.3.4.1 General

Subclauses 4.3.4.1 of EN 13369:2004 shall apply.

4.3.4.2 Resistance to fire

Subclauses 4.3.4.2 and 4.3.4.3 of EN 13369:2004 shall apply.

4.3.4.3 Reaction to fire

Subclause 4.3.4.4 of EN 13369:2004 shall apply.

4.3.5 Acoustic properties

Subclause 4.3.5 of EN 13369:2004 shall apply.

4.3.6 Thermal properties

Subclause 4.3.6 of EN 13369:2004 shall apply.

4.3.7 Durability

Subclause 4.3.7 of EN 13369:2004 shall apply, except for the minimum concrete cover for stair corbels defined in subclause 4.3.9.

4.3.8 Other requirements

Subclause 4.3.8 of EN 13369:2004 shall apply.

4.3.9 Detailing

The detailing of the element, with respect to geometrical data and complementary properties of materials and inserts shall be given in technical documentation, which shall include the construction data, such as the dimensions, the tolerances, the layout of reinforcement, the concrete cover, the expected transient and final support conditions and lifting conditions. In particular, the technical documentation shall include the maximum acceptable gap between components when erected to ensure the design overlap of the reinforcement is achieved (see 10.9.4.7 of EN 1992-1-1:2004).

The design of the bearings shall be in accordance with 10.9.5 of EN 1992-1-1:2004 and due allowances shall be made for erection tolerances.

For the application of this rule, two classes of stair corbels are defined (Figure 1) :

- Class A : the stair corbel is manufactured with the design cover according to 4.3.1.1 ;
- Class B : the stair corbel is similar to class A but with a reduced cover at the extreme end. In this case the concrete cover is achieved on site with a non shrink mortar. The mortar and its minimum thickness shall respect Clause 4 of EN 1992-1-1:2004.

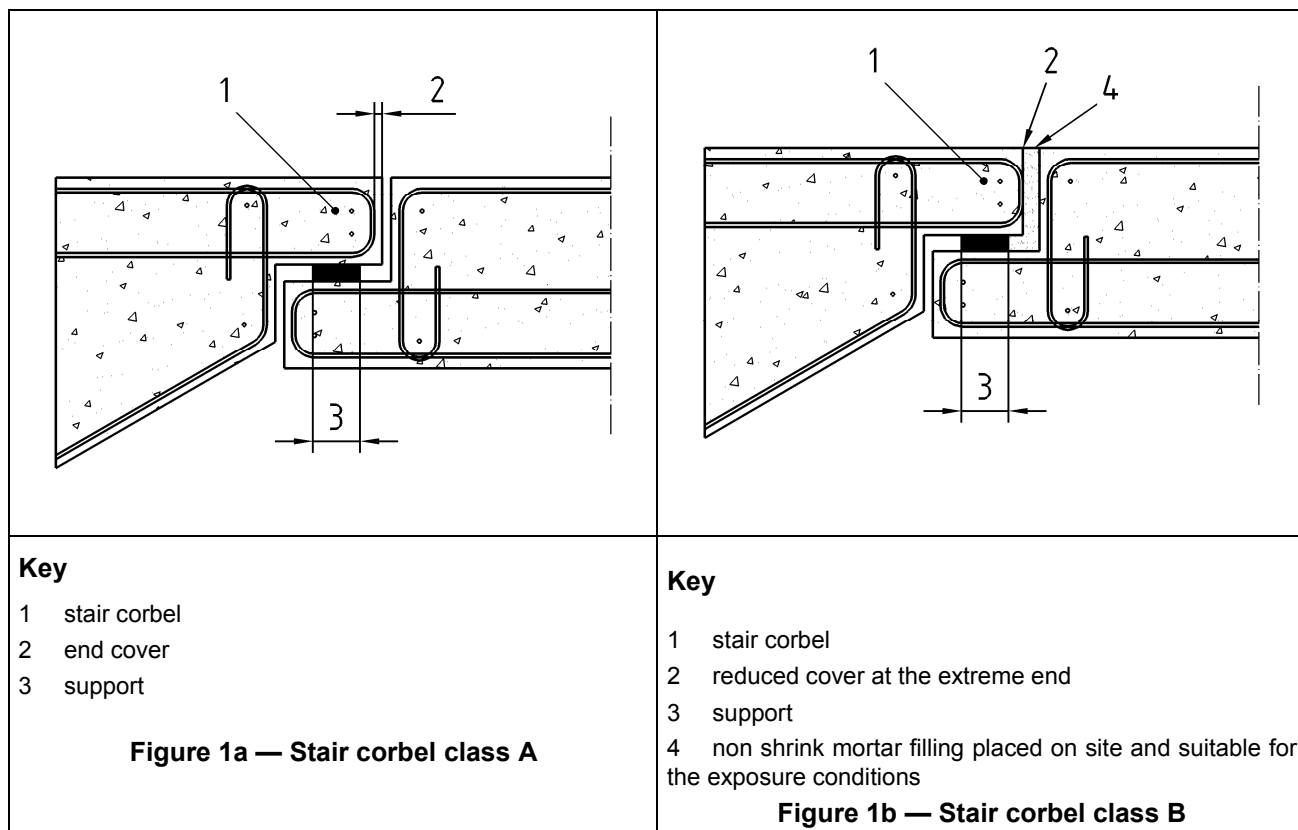

Figure 1 — Definition of classes of stair corbels

NOTE Consideration should be given to the use of stainless or protected reinforcement to ensure adequate durability of stair corbel class B.

5 Test methods

5.1 Tests on concrete

Subclause 5.1 of EN 13369:2004 shall apply.

5.2 Measuring of dimensions and surface characteristics

Subclause 5.2 of EN 13369:2004 shall apply.

With reference to Figure J.5 of EN 13369:2004, ruler of 200 mm or 1 000 mm may be used according to the dimensions being verified.

5.3 Weight of the product

Subclause 5.3 of EN 13369:2004 shall apply.

6 Evaluation of conformity

Clause 6 of EN 13369:2004 shall apply.

Table 4 replaces item 2 of Table D.4 of EN 13369:2004.

Table 4 — Finished product inspection

	SUBJECT	METHOD	PURPOSE	FREQUENCY
D.4.1 - Product Testing				
1	Final inspection	Measuring of dimensions (see 5.2)	Conformity with the requirements of this standard and the requirements for the manufacturer declared properties	At least one stair in every ten per model manufactured.
2	Surface characteristics	Measuring according to 5.2.	Conformity to 4.3.2	At least one stair in every ten per model manufactured.

7 Marking

Clause 7 of EN 13369:2004 shall apply.

8 Technical documentation

Clause 8 of EN 13369:2004 shall apply.

Annex A (informative)

Stairs — Terms and definitions

Table A.1 — Classification by reference

Reference	Term	Definition
1.1	General	See Figure A.1
1.1.1	Stair	A succession of horizontal stages (steps or landings) at a pitch which makes it possible to pass on foot to other levels.
1.1.2	Individual step	Precast product providing a single tread and riser. NOTE Individual steps may have an integral boss at one end to facilitate the construction of the central column of a spiral stair or they may be designed to be assembled into a stair with strings, carriages or other supports.
1.1.3	Prefabricated stair	A stair which is manufactured either complete or in component form, later to be installed and/or assembled in its final location.
1.1.4	Stair enclosure	The space reserved for accommodating a stair and faces of the walls limiting its volume.
1.1.5	Stairwell	The void formed on the inside by the shape of a stair.
1.1.6	Landing	A level platform at the end of a flight or between two flights of stairs. It can be part of the stair or of the floor.
1.1.7	String	An inclined member supporting the end(s) of steps.
1.1.8	Fixing	A component to secure a stair to its support(s).
1.1.9	Bearing	A support upon which a precast product rests.
1.1.10	Corbel	A projection from an element to form a bearing.
1.1.11	Lap joint (rebated joint)	A pair of overlapping corbels transmitting load.
1.1.12	Wall	An element which divides or encloses an area. It may be loadbearing or not.
1.1.13	Hollow element	A precast element with internal voids.
1.1.14	Parapet	An element providing protection against falling over an edge.
1.2	Stair types and layouts	See Figure A.2.
1.2.1	Straight stair	Stair in which the direction is the same throughout.
1.2.2	Flight	An unbroken series of steps between two landings.
1.2.3	Intermediate or rest landing	A landing inserted between two floors.
1.2.4	Double return stair	Turning stair with one flight to an intermediate landing and two flights from that landing.
1.2.5	Turning stair	Stair in which the direction changes.
1.2.6	Left-hand (or right- hand) stair	Stair turning to the left hand(or right hand) when ascending.
1.2.7	Winding stair	Stair which changes direction by using tapered steps.
1.2.8	Monolithic stair	A stair cast as a single piece.
1.2.9	Open well stair	Turning stair around a stairwell.

Table A.1 — Classification by reference (*continued*)

Reference	Term	Definition
1.2.10	Helical stair	Winding stair that describes a helix around a stairwell.
1.2.11	Spiral stair	Winding stair that describes a helix around a central column.
1.3	Dimensions	See Figure A.3.
1.3.1	Stair opening	A space reserved in a floor for a stair.
1.3.2	Floor to floor height	The dimension measured vertically from the finished surface of one floor level to the finished surface of the next.
1.3.3	Pitch line	A notional line connecting the nosings of successive steps usually taken on the walking line.
1.3.4	Pitch	The angle between the pitch line and the horizontal plane.
1.3.5	Headroom	The minimum unobstructed vertical dimension above the pitch line.
1.3.6	Rise	The vertical dimension from the surface of one tread to the surface of the next.
1.3.7	Going (run)	The horizontal dimension between the nosings of two consecutive steps, measured on the walking line.
1.3.8	Tread width	The horizontal dimension from the nosing to the back of a tread.
1.3.9	Overlap	Horizontal dimension between the rear edge of a tread and the consecutive nosing above.
1.3.10	Stair width	Horizontal dimension of the treads taken at right angles to the walking line.
1.3.11	Stair clear width	Unobstructed horizontal dimension taken at right angles to the walking line to allow the passage of people and objects.
1.3.12	Width over strings	Horizontal dimension between the outer faces of the strings.
1.3.13	Walking line	A theoretical line indicating the usual path of the users of the stair. NOTE An arrow on this line always indicates the direction of ascent.
1.3.14	Walking zone	Notional width occupied by a single person ascending the stair.
1.4	Types of steps	See Figure A.4.
1.4.1	Winder	A step in which the nosing of the tread is not parallel to the nosing of the step or landing immediately above it.
1.4.2	Top step	The uppermost step of a flight.
1.4.3	Bottom step	The step containing the first riser mounted when ascending the stair.
1.5	Stair components	See Figure A.5.
1.5.1	Step	Part of a stair consisting of a tread and a riser.
1.5.2	Tread	The horizontal component or upper surface of a step.
1.5.3	Riser	The part closing the front face of the step.
1.5.4	Open rise stair	A stair in which the vertical spaces between successive treads are either open or not fully filled by risers.
1.5.5	Nosing	Projecting front edge of a tread or landing.
1.5.6	Carriage	Member under the steps to give them support.
1.5.7	Waist	Structural component of a stair supporting the steps.
1.5.8	Column	Vertical structural element of a stair with a width not greater than 4 times its thickness.
1.5.9	Spandrel	Central wall of a winding stair that may provide support for the stair.
1.5.10	Boss	An annular component of steps intended for use in spiral stairs that enables the central column to be formed.

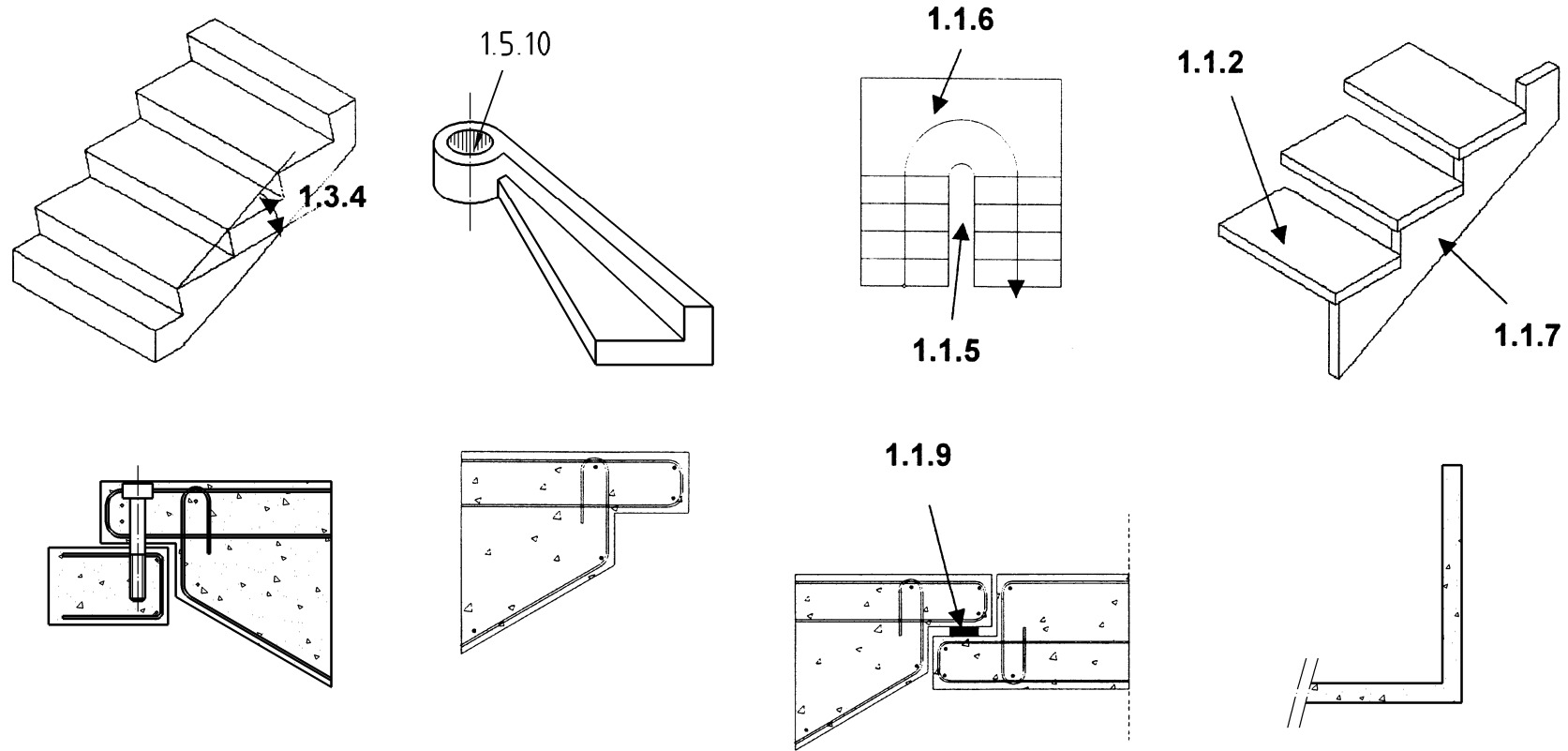

NOTE Reinforcement arrangements are illustrative only

Figure A.1 — General terms

EN 14843:2007(E)

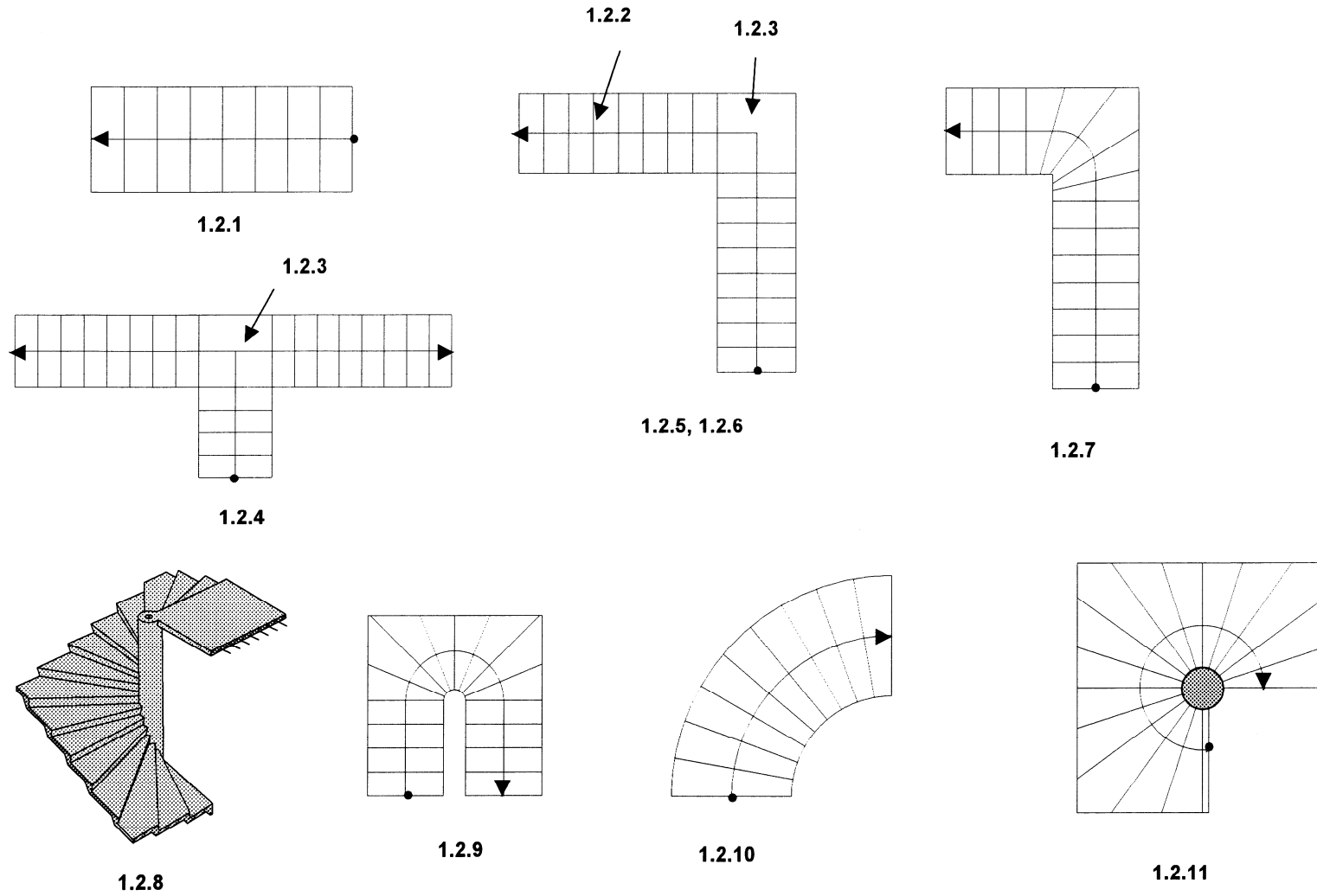

Figure A.2 — Stair types and layouts

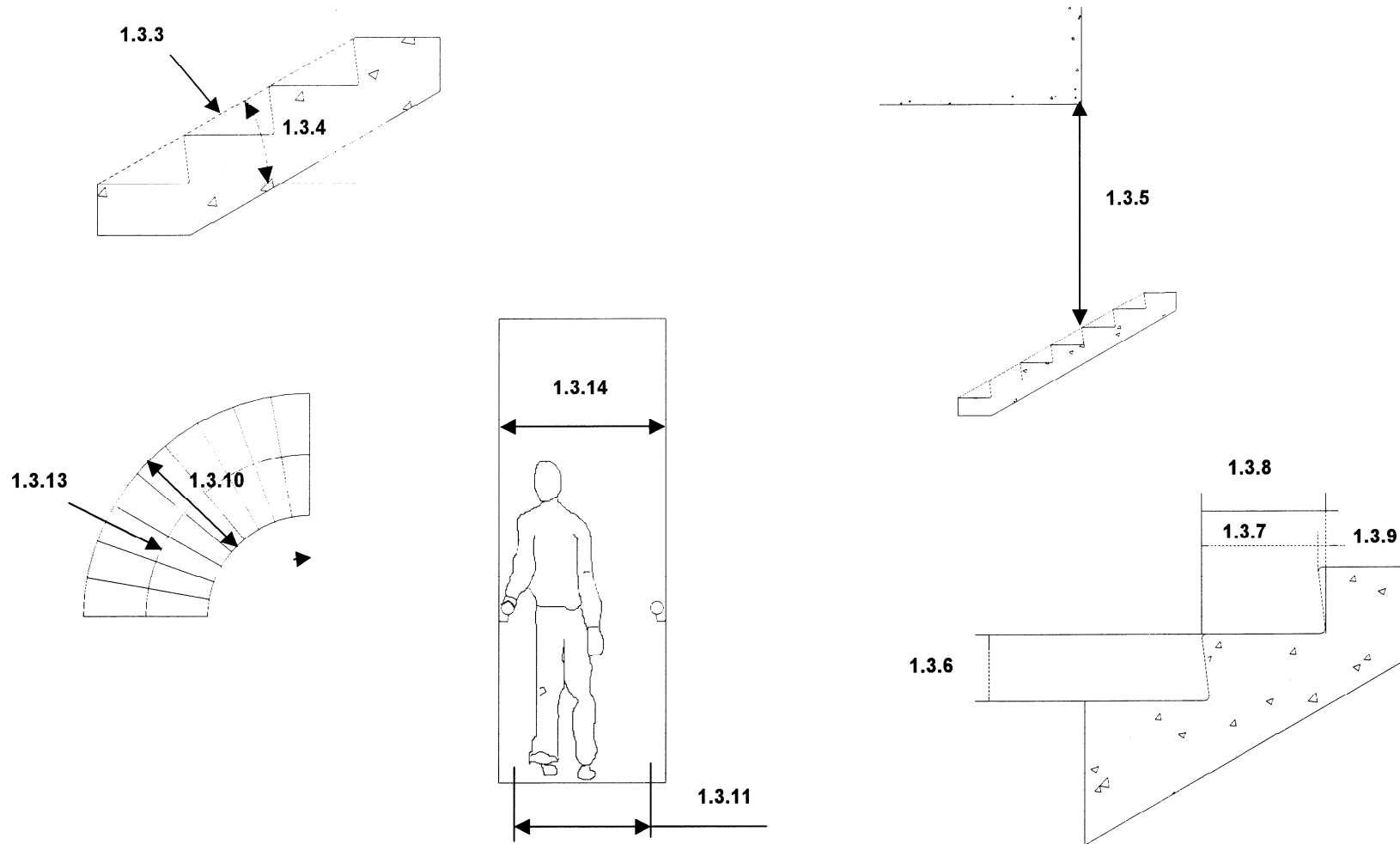

Figure A.3 — Dimensions

EN 14843:2007(E)

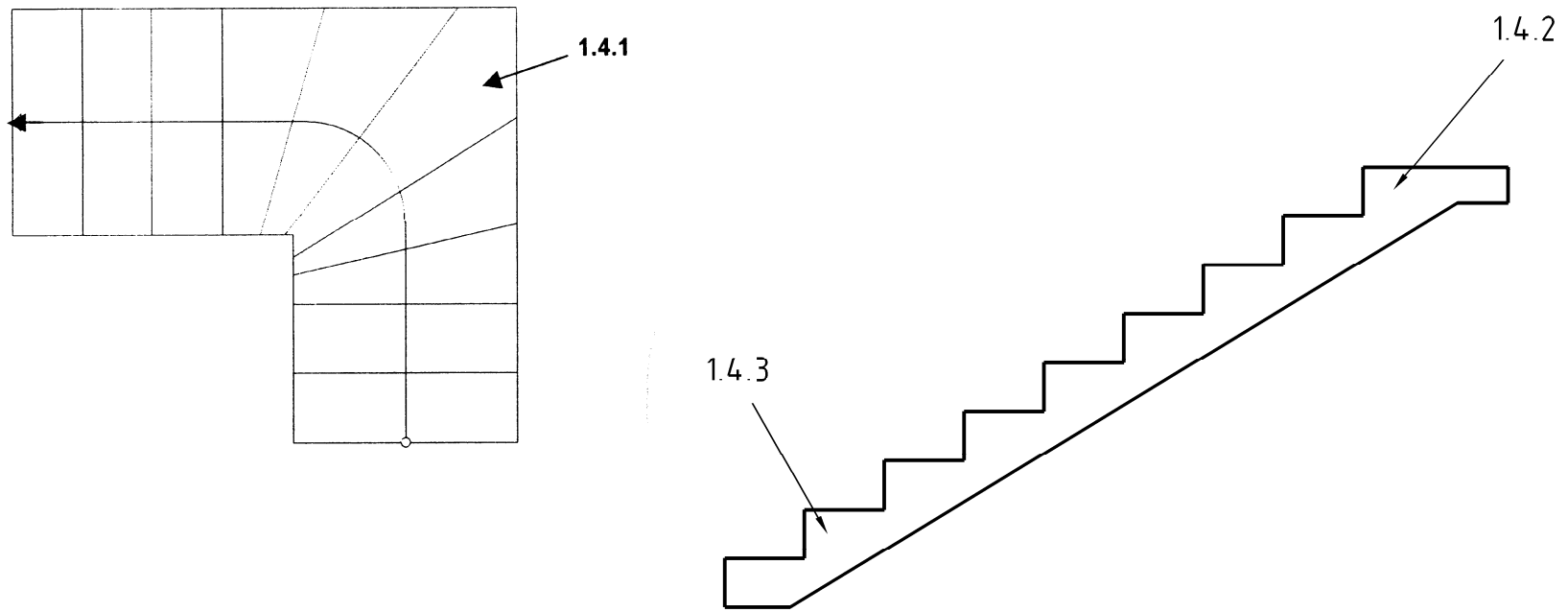

Figure A.4 — Types of steps

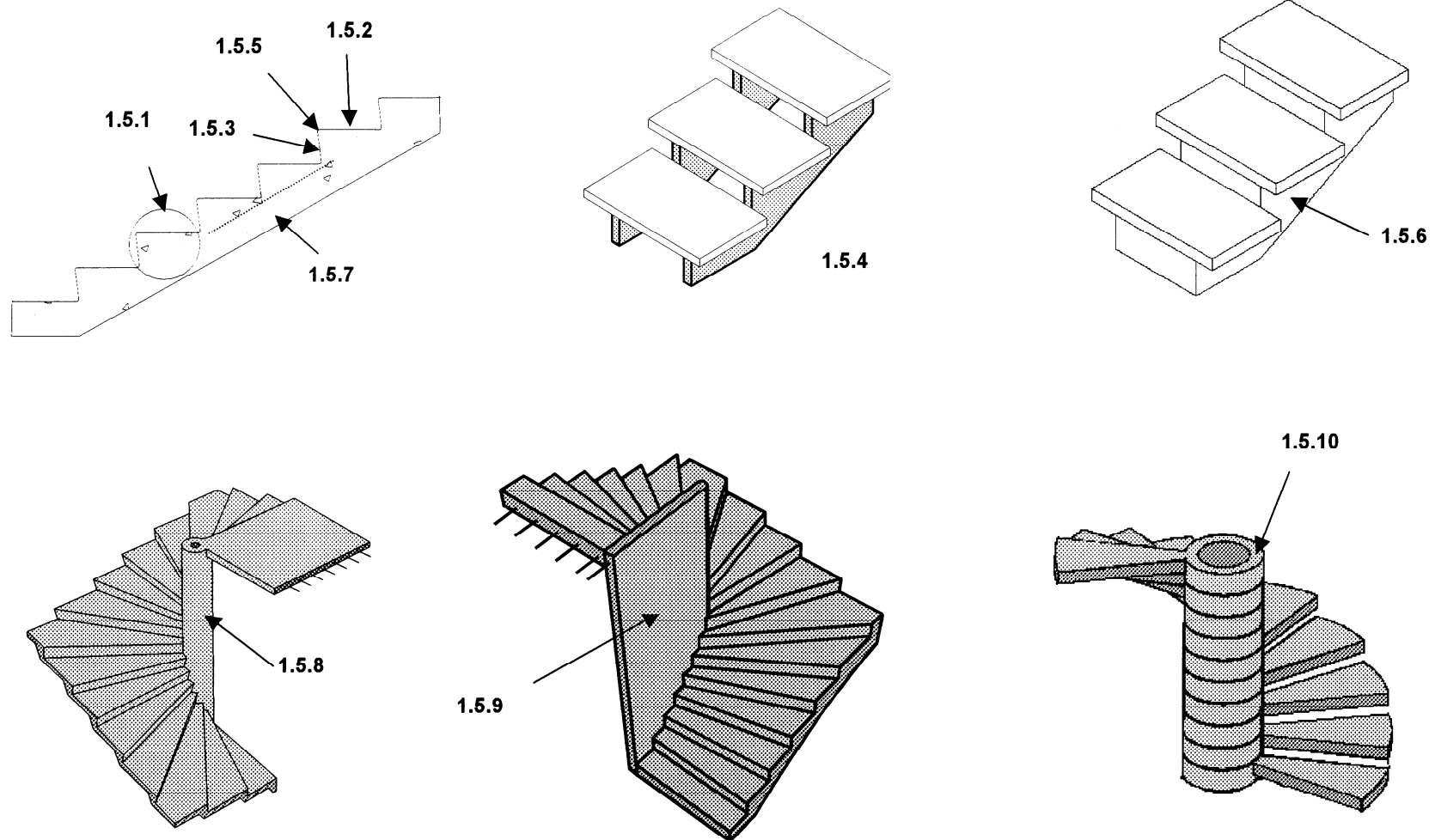

Figure A.5 — Stair components

Annex B (informative)

Test method

B.1 Objectives

Load tests should be carried out initially as necessary to verify the reliability of the design model assumed for calculation (see 4.3.3.3 of EN 13369:2004).

NOTE Further guidance may be found in CEN/TR 14862, *Precast concrete products — Full-scale testing requirements in standards on precast concrete products*.

B.2 Specification and selection of specimens

B.2.1 Identification of product group

The producer should identify the group of elements that will be treated as having the same product properties. For each group a specific set of product properties should be defined as representative for the group.

B.2.2 Design of test specimens

The producer should prepare and record a test plan containing appropriate drawings and documents describing the test specimens and their relations to the groups defined in B.2.1.

A minimum of three specimens for each group should be tested.

a) Monolithic stairs :

for monolithic stairs with steps less than 80 mm thick, a test may be carried out in which a concentrated test load is applied to take account of the dynamic effects of the normal use of the stair (Figure B.1) ;

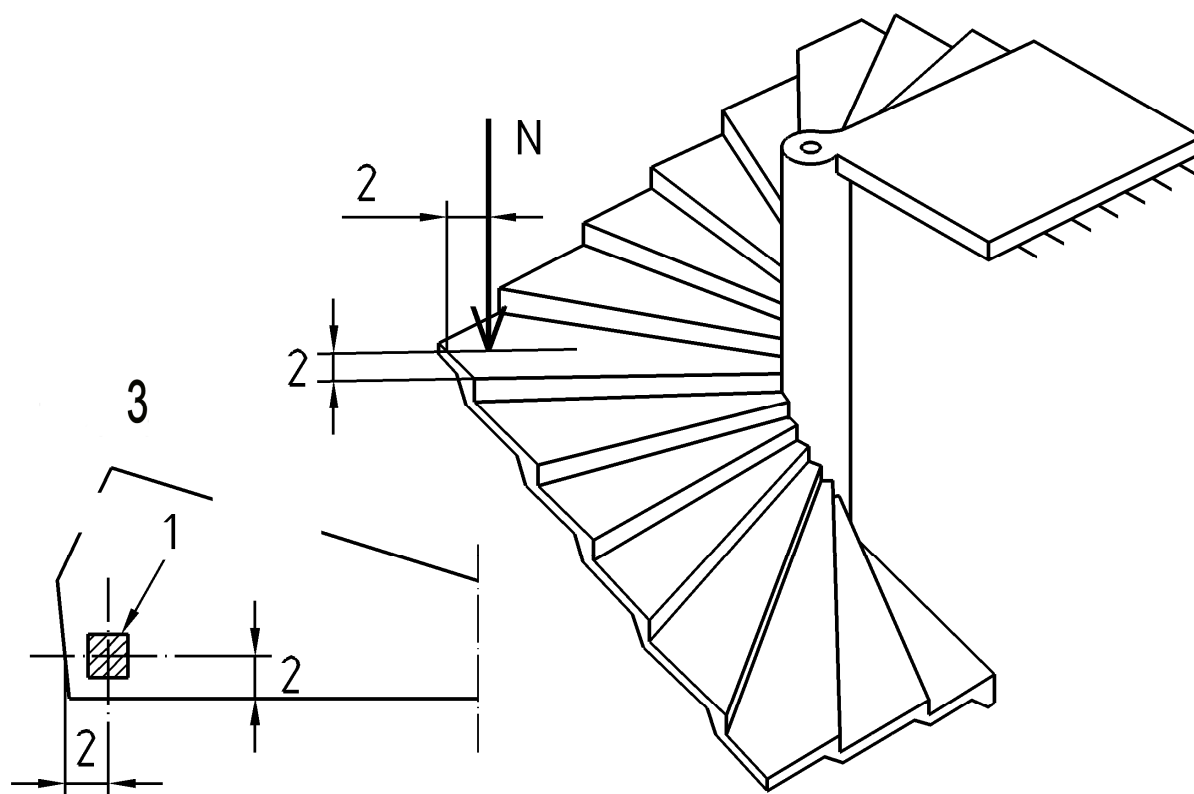

Key

- 1 hardwood cube 100 mm × 100 mm × 100 mm
- 2 dimensions = 100 mm
- 3 detail

Figure B.1 — Example of test for a stair with thin steps

b) Individual steps :

individual steps may be load tested when installed in a test rig designed to hold the step as when it is installed in a building.

Examples of test arrangements are shown in Figures B.2 to B.4.

— individual step on two supports :

- The test load is centred at the mid-span where there is a single walking zone (Figure B.2) or at the centre of each walking zone where there is more than one. In case of a step containing a cantilever part, a second test loading scheme is defined to test this part (Figure B.3). In this last case, the step may be restrained by fixings as intended for use on site to evaluate their suitability or the step may be held in a supplementary support to avoid rocking.

— individual step with an integral boss (e.g. for a spiral stair) :

- The test load is placed close to the end of the walking zone, as shown in Figure B.4.

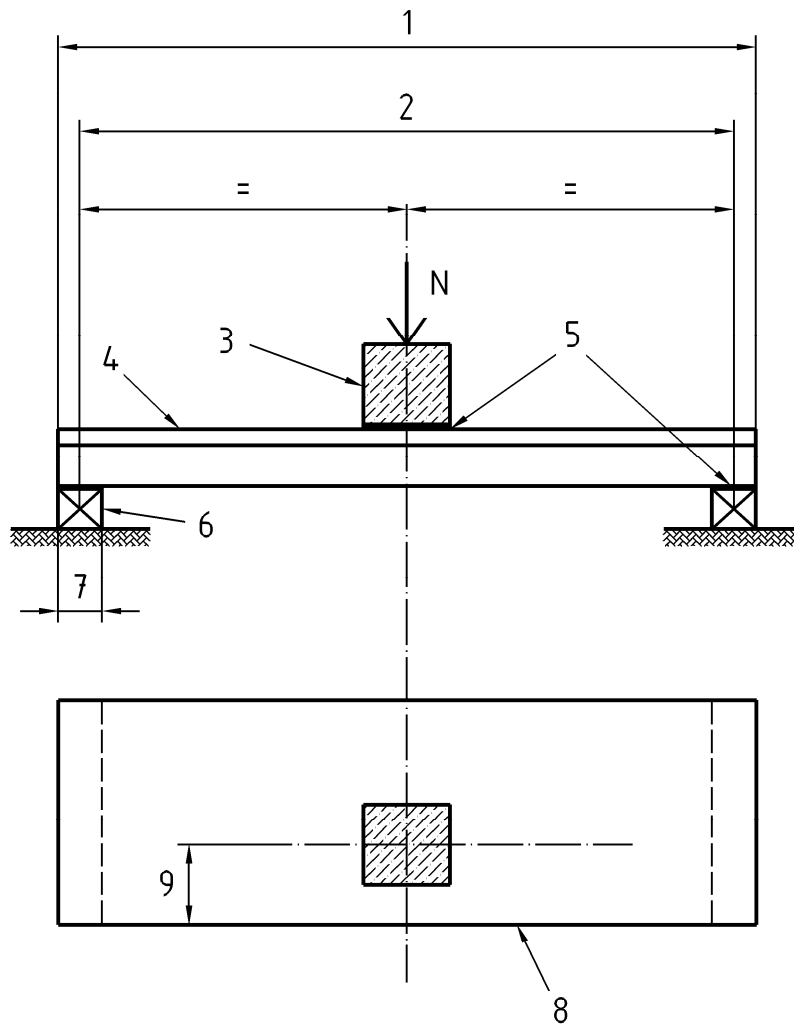

Key

- 1 walking zone
- 2 span
- 3 hardwood cube 100 × 100 × 100 mm
- 4 top face with its finishes
- 5 rubber plate-Thickness 5 mm
- 6 supporting beam
- 7 support width defined by the producer
- 8 nosing
- 9 dimension 100 mm

Figure B.2 — Example of test arrangement for an individual step providing one walking zone and supported by two carriages

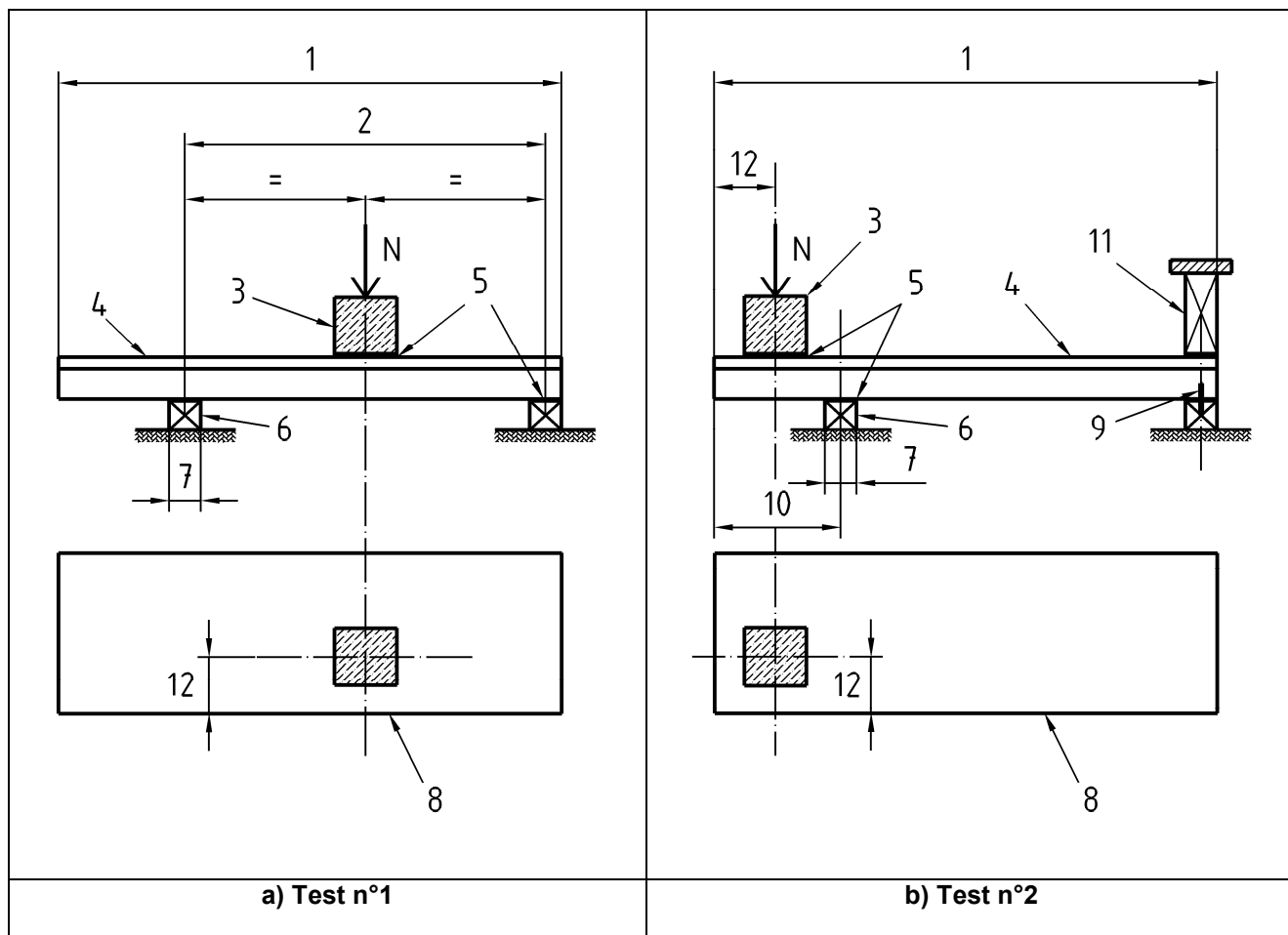
**Key**

- 1 walking zone
- 2 span
- 3 hardwood cube 100 × 100 × 100 mm
- 4 top face with its finishes
- 5 rubber plate-Thickness 5 mm
- 6 supporting beam
- 7 support width defined by the producer
- 8 nosing
- 9 fixing
- 10 cantilever part
- 11 supplementary support (if no fixing (9) is provided)
- 12 dimension 100 mm

Figure B.3 — Example of test arrangement for an individual step having a cantilever part providing one walking zone and supported by two carriages

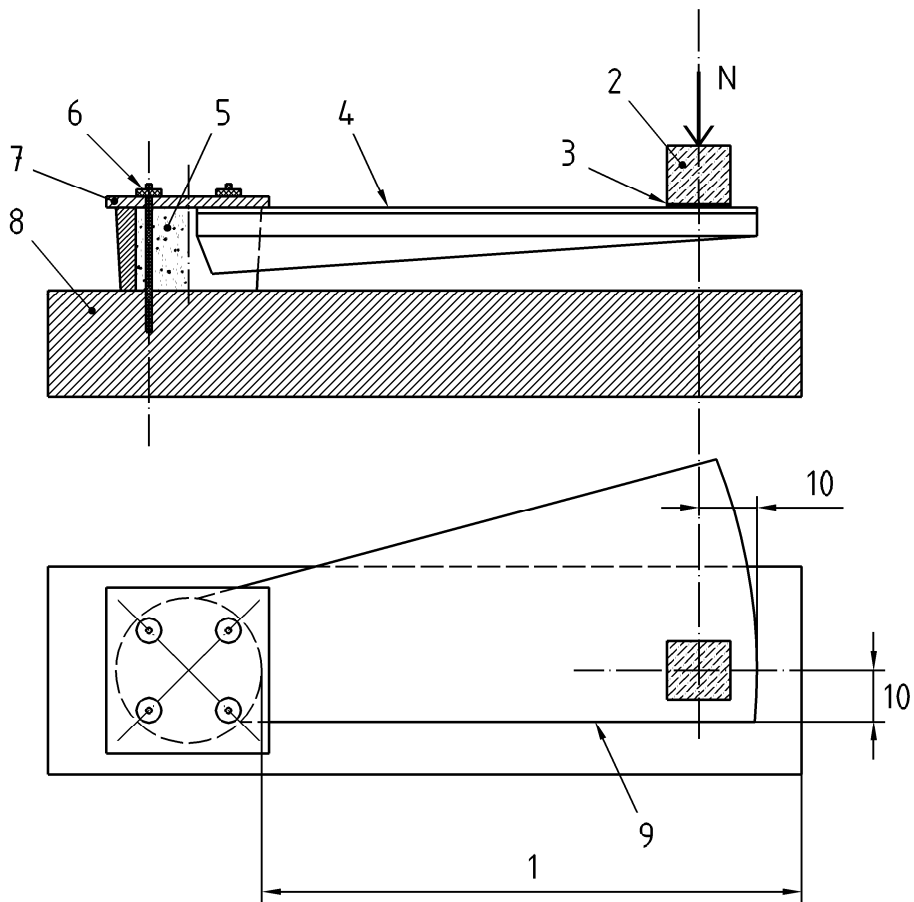

Key

- 1 walking zone
- 2 hardwood cube 100 × 100 × 100 mm
- 3 rubber plate-Thickness 5 mm
- 4 top face with its finishes
- 5 in situ concrete
- 6 fixing
- 7 steel plate
- 8 supporting beam
- 9 nosing
- 10 dimension 100 mm

Figure B.4 — Example of test arrangement for an individual step from a spiral stair providing one walking zone

Annex Y (informative)

Choice of CE marking method

The producer should choose to apply, for CE marking, one of the methods described in ZA.3, on the basis of the following conditions.

Y.1 Method 1

The declaration of geometrical data and material properties as specified in ZA.3.2 may be applied when the following condition occurs :

- off the shelf and catalogue products.

Y.2 Method 2

The declaration of product properties determined following this standard and EN Eurocodes, as specified in ZA.3.3, should be applied when the following condition occurs :

- precast product with product properties declared by the producer.

Y.3 Method 3

The declaration of compliance with a given specification as specified in ZA.3.4 may be applied when the following condition occurs :

- all other cases than Y.1 and Y.2.

Annex ZA (informative)

Clauses of this European Standard addressing the provisions of the EU Constructions Product Directive

ZA.1 Scope and relevant characteristics

This European Standard has been prepared under the mandate M/100¹ "Precast Concrete Products" given to CEN by the European Commission and the European Free Trade Association.

The clauses of this European Standard shown in this annex meet the requirements of the mandate given under the EU Construction Products Directive (89/106/EEC).

Compliance with these clauses confers a presumption of fitness of the precast concrete stairs covered by this annex for the intended uses indicated herein; reference shall be made to the information accompanying the CE marking.

WARNING — Other requirements and other EU Directives, not affecting the fitness for intended uses, may be applicable to the stairs falling within the scope of this standard.

NOTE 1 In addition to any specific clauses relating to dangerous substances contained in this standard, there may be requirements applicable to the products falling within its scope (e.g. transposed European legislation and national laws, regulations and administrative provisions). In order to meet the provisions of the EU Construction Products Directive, these requirements need also to be complied with, when and where they apply.

NOTE 2 An informative database of European and national provisions on dangerous substances is available at the Construction web site on EUROPA (accessed through <http://europa.eu.int/comm/enterprise/construction/internal/dangsub/dangmain.htm>).

This annex establishes the conditions for CE marking of precast concrete stairs made of reinforced or prestressed concrete, used indoor or outdoor as structural stairs and shows the relevant clauses applicable.

This annex has the same scope as Clause 1 of this standard and is defined by Table ZA.1.

¹ As amended

Table ZA.1 — Construction product: precast concrete stairs
Intended use: structural, indoor or outdoor

Essential characteristics		Requirement clauses in this standard		Levels and/or class(es)	Notes and Unit
Compressive strength (of concrete)	All methods	4.2	Production requirements	None	N/mm ²
Ultimate tensile and tensile yield strength (of steel)	All methods	4.1.3 4.1.4	of EN 13369:2004 and of EN13369:2004	None	N/mm ²
Load bearing capacity or Mechanical strength	Method 1	Information listed in ZA.3.2		None	Geometry and materials
	Method 2	4.3.3	Mechanical resistance	None	kN, kN/m ²
	Method 3	Design specification		None	
Resistance to fire	Method 1	Information listed in ZA.3.2		R, REI	Geometry and materials
	Method 2	4.3.4.2	Resistance to fire	R, REI	min
	Method 3	Design specification		R, REI	min
Detailing	All methods	4.3.1	Geometrical properties	None	mm
		4.3.9	Detailing	None	/
		8	Technical documentation	None	/
Impact noise transmission	All methods	4.3.5	Acoustic properties	None	dB
Safety in use	All methods	4.3.8.2	Safety in use of EN 13369	None	Geometry
Durability against corrosion	All methods	4.3.7	Durability	None	Ambient conditions
Method 1 = declaration of geometrical data and material properties (see ZA.3.2).					
Method 2 = declaration of the value of the product properties (see ZA.3.3).					
Method 3 = declaration of compliance with given design specification (see ZA.3.4).					

The producer shall select when he applies each method in accordance with Annex Y.

The requirement on a certain characteristic is not applicable in those Member States (MSs) where there are no regulatory requirements for that characteristic for the intended use of the product. In this case, manufacturers placing their products on the market of these MSs are not obliged to determine nor to declare the performance of their products with regard to this characteristic and the option "No performance determined" (NPD) in the information accompanying the CE marking (see ZA.3) may be used. The NPD option may not be used, however, where the characteristic is subject to a threshold level.

ZA.2 Procedure for attestation of conformity of stairs

ZA.2.1 System of attestation of conformity

The system of attestation of conformity of precast concrete stairs, for the essential characteristics indicated in Table ZA.1, in accordance with the decision of the Commission 1999/94/EC of 25 January 1999 as given in Annex III of the Mandate M/100 "Precast concrete products", is shown in Table ZA.2, for the indicated intended use and relevant levels or classes:

Table ZA.2— System of attestation of conformity

Product(s)	Intended use(s)	Level(s) or class(es)	Attestation of conformity system(s)
<i>Stairs</i>	<i>Structural</i>	-	2+
System 2+ See Directive 89/106 (CPD) Annex III-2 (ii) First possibility, including certification of the factory production control by an approved body on the basis of initial inspection of factory and of factory production control as well as of continuous surveillance, assessment and approval of factory production control.			

The attestation of conformity of precast concrete stairs, for the essential characteristics indicated in Table ZA.1, shall be based on the evaluation of conformity procedure indicated in Table ZA.3, resulting from the application of the clauses of this or other European Standards indicated therein.

Licensed copy: PONTYPRIDD COLLEGE, 05/01/2008, Uncontrolled Copy, © BSI

Table ZA.3 — Assignment of evaluation of conformity tasks for stairs under system 2+

Tasks		Content of the tasks	Evaluation of conformity clauses to apply
Tasks for the manufacturer	Initial type testing	All characteristics of Table ZA.1	Clause 6 of EN 13369:2004
	Factory production control	Parameters related to all characteristics of Table ZA.1	Clause 6 of this standard and 6.3 of EN 13369:2004
	Further testing of samples taken at the factory	All characteristics of Table ZA.1	6.2.3 of EN 13369:2004
Tasks for the notified body	Certification of factory production control on the basis of :	Initial inspection of factory and of factory production control	6.1.3.2a and 6.3 of EN 13369:2004 and Clause 6 of this standard
		Continuous surveillance, assessments and approval of factory production control	6.1.3.2b and 6.3 of EN13369:2004 and 6 of this standard

^a For fire resistance (when verified by testing) tests should be carried out by testing laboratory.

ZA.2.2 EC Certificate and Declaration of conformity

When compliance with the conditions of this annex is achieved, and once the notified body has drawn up the certificate mentioned below, the manufacturer or his agent established in the EEA shall prepare and retain a declaration of conformity, which entitles the manufacturer to affix the CE marking. This declaration shall include :

- name and address of the manufacturer, or his authorised representative established in the EEA, and the place of production ;

NOTE 1 The manufacturer may also be the person responsible for placing the product onto the EEA market, if he takes responsibility for CE marking.

- description of the product (type, identification, use, ...), and a copy of the information accompanying the CE marking ;

NOTE 2 Where some of the information required for the Declaration is already given in the CE marking information, it does not need to be repeated.

- provisions to which the product conforms (e.g. Annex ZA of this EN) ;
- particular conditions applicable to the use of the product (e.g. provisions for use under certain conditions, etc) ;
- number of the accompanying factory production control certificate ;
- name of, and position held by, the person empowered to sign the declaration on behalf of the manufacturer or his authorised representative.

The declaration shall be accompanied by a factory production control certificate, drawn up by the notified body, which shall contain, in addition to the information above, the following :

- name and address of the notified body ;
- number of the factory production control certificate ;
- conditions and period of validity of the certificate, where applicable ;
- name of, and position held by, the person empowered to sign the certificate.

The above mentioned declaration and the certificate shall be presented in the official language or languages of the Member State in which the product is to be used.

ZA.3 CE marking and labelling

ZA.3.1 General

The manufacturer or his authorised representative established within the EEA is responsible for the affixing of the CE marking. The CE marking symbol to affix shall be in accordance with Directive 93/68/EC and shall be shown on the product (or when not possible it may be on the accompanying label, the packaging or on the accompanied commercial documents e.g. a delivery note).

The following information shall be added to the CE marking symbol :

- identification number of the certification body ;
- name or identifying mark and registered address of the producer ;
- last two digits of the year in which the marking is affixed ;
- number of the EC factory production control certificate ;
- reference to this European Standard ;
- description of the product: generic name and intended use ;
- information on those relevant essential characteristics taken from Table ZA.1 which are listed in the relevant Clause ZA.3.2, ZA.3.3 or ZA.3.4 ;

- "No performance determined" for characteristics where this is relevant.

The "No performance determined" (NPD) option may not be used where the characteristic is subject to a threshold level. Otherwise, the NPD option may be used when and where the characteristic, for a given intended use, is not subject to regulatory requirements in the Member State of destination.

In the following subclauses the conditions are given for the application of CE marking. Figure ZA.1 gives the simplified label to affix to the product, containing the minimum set of information and the link to the accompanying document where the other required information are given. For what concern the information on essential characteristics, some of them may be given by an unambiguous reference to :

- technical information (product catalogue) (see ZA.3.2) ;
- technical documentation (ZA.3.3) ;
- design specification (ZA.4).

The minimum set of information to be put directly in the affixed label or in the accompanying document is given in Figures ZA.2, ZA.3 and ZA.4.

ZA.3.1.1 Simplified label

In the case of simplified label the following information shall be added to the CE marking symbol :

- name or identifying mark and registered address of the producer ;
- identification number of the unit (to ensure traceability) ;
- last two digits of the year in which the marking is affixed ;
- number of the CE factory production control certificate ;
- reference to this European Standard.

The same identification number shall mark, in the accompanying documents, the information related to the unit.

Figure ZA.1 gives the simplified label to affix to the product, containing the minimum set of information. The other information defined in ZA.3.1 and not given with the simplified label shall be provided with the accompanying documents.

	CE conformity marking consisting of the CE symbol given in Directive 93/68/EEC
AnyCo Ltd, PO Bx 21, B-1050 45PJ76/07	Name or identifying mark and registered address of the producer Identification number of the unit and last two digits of the year in which the marking was affixed
0123-CPD-0456 EN 14843	Number of the FPC certificate (the four first Figures – 0123 - represent the reference number of the notified body) Number of this European Standard

Figure ZA.1 — Example of simplified label

ZA.3.2 Declaration of geometrical data and material properties

(Method 1 to determine properties relating to essential requirements "mechanical resistance and stability" and "resistance to fire".)

Figure ZA.2 gives, for precast concrete stairs, the model CE marking inclusive of the information needed to determine, according to design regulation valid in the place of use, the properties related to mechanical resistance and stability and resistance to fire, including aspects of durability and serviceability.

Referring to Table ZA.1 and to the information quoted in the list of ZA.3.1, the following properties shall be declared :

- compressive strength of concrete ;
- ultimate tensile strength of reinforcing steel ;
- tensile yield strength of reinforcing steel ;
- ultimate tensile strength of prestressing steel ;
- tensile 0,1 proof stress of prestressing steel ;
- geometrical data (only critical dimensions) ;
- conditions for durability ;
- possible reference to Technical Information (product catalogue) for detailing, durability and geometrical data.

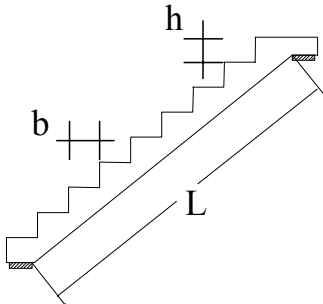
 0123
AnyCo Ltd, PO Bx 21, B-1050 07
0123-CPD-0456 EN 14843 Precast concrete stairs External stairs Concrete : Compressive strength $f_{ck} = xx \text{ N/mm}^2$ Reinforcing steel : Ultimate tensile strength $f_{tk} = yyy \text{ N/mm}^2$ Tensile yield strength $f_{yk} = zzz \text{ N/mm}^2$  Stair width mm For detailing and durability see Technical Information Technical Information : Product Catalogue ABC : 2002 – clause ii

CE conformity marking consisting of the CE symbol given in Directive 93/68/EEC

Identification of the notified body

Name or identifying mark and registered address of the producer

Last two digits of the year in which the marking was affixed

Number of the FPC certificate

Number and title of European Standard concerned

Generic name and intended use

Information on product geometry and material characteristics including detailing (to be adapted to the specific product by the producer)

NOTE The sketch may be omitted if equivalent information are available in clearly identified Technical Information (product catalogue) referred to.

Figure ZA.2 — Example of CE marking with Method 1

ZA.3.3 Declaration of product properties

(Method 2 to determine properties relating to essential requirements "mechanical resistance and stability" and "resistance to fire".)

For all design data, including models and parameters used in calculation, reference may be made to the technical (design) documentation.

Referring to Table ZA.1 and to the information quoted in the list of ZA.3.1, the following properties shall be declared :

- compressive strength of concrete ;

- ultimate tensile strength of reinforcing steel ;
- tensile yield strength of reinforcing steel ;
- ultimate tensile strength of prestressing steel ;
- tensile 0,1 proof stress of prestressing steel ;
- mechanical ultimate strength of the element (calculated design values for non-seismic situations) with bending moment capacity, shear and torsional capacity of critical sections ;
- safety factors for concrete and steel used in calculation ;
- resistance to fire R class (for specific use also resistance to fire E and I shall be added) ;
- other Nationally Determined Parameters NDPs used in calculation ;
- airborne sound insulation ;
- conditions for durability against corrosion ;
- possible reference to Technical Documentation for geometrical data, detailing, durability, other NDPs, acoustic insulation parameters and thermal resistance.

Figure ZA.3 gives, for precast concrete stairs, the model CE marking in the case in which the properties related to mechanical resistance and stability and resistance to fire are determined by the producer by means of EN Eurocodes.

The design values of the mechanical ultimate strength of the element and the resistance to fire class shall be computed using, for the Nationally Determined Parameters, either the values recommended in EN 1992-1-1 and EN 1992-1-2 or the values given in the National Annex of the Eurocodes applicable to the works.

 0123
AnyCo Ltd, PO Bx 21, B-1050 07
0123-CPD-0456 EN 14843 Precast concrete stairs External stairs Concrete : Compressive strength $f_{ck} =$ xx N/mm ² Reinforcing steel : Ultimate tensile strength $f_{tk} =$ yyy N/mm ² Tensile yield strength $f_{yk} =$ zzz N/mm ² Prestressing steel : Ultimate tensile strength $f_{pk} =$ uuu N/mm ² Tensile 0,1% proof-stress $f_{p0.1k} =$ www N/mm ² Mechanical ultimate strength (design value) : Load capacity (total loading condition) ppp kN/m ² Material safety factors applied in strength calculation : For concrete $\gamma_c =$ z.zz For steel $\gamma_s =$ x.xx Resistance to fire RXX for $\eta_{fi} =$ 0.xx RYY for $\eta_{fi} =$ 0.yy For geometrical data, detailing, durability, airborne sound insulation and other NDPs see the Technical documentation Technical Documentation : Position Number xxxxxx

Figure ZA.3 — Example of CE marking with Method 2 (verification by calculation)

CE conformity marking consisting of the CE symbol given in Directive 93/68/EEC

Identification of the notified body

Name or identifying mark and registered address of the producer

Last two digits of the year in which the marking was affixed

Number of the FPC certificate

Number and title of European Standard concerned

Generic name and intended use

Information on product mandated characteristics including detailing (to be adapted to the specific product by the producer)

NOTE The values of Resistance to fire may be replaced by a reference to the pertinent part of Technical documentation.

ZA.3.4 Declaration of compliance with a given design specification

(Method 3 to determine properties relating to essential requirements "mechanical resistance and stability" and "resistance to fire").

The Method 3 applies in the following situations :

- for cases in which a structural component or kit is produced in accordance with the design details (drawings, material specifications, etc.) prepared by the designer of the works ;

- b) for cases in which the producer has designed and produced a structural component or kit following the provisions of the client's order.

Figure ZA.4 gives, for precast concrete stairs, the model CE marking in the case the product is produced according to a design specification in which the properties related to mechanical resistance and stability and resistance to fire are determined by means of design provisions applicable to the works.

Referring to Table ZA.1 and to the information quoted in the list of ZA.3.1, the following properties shall be declared :

- compressive strength of concrete ;
- ultimate tensile strength of reinforcing steel ;
- tensile yield strength of reinforcing steel ;
- ultimate tensile strength of prestressing steel ;
- tensile 0,1 proof stress of prestressing steel.

This method applies also in case of a design made with means other than EN Eurocodes.

 0123
AnyCo Ltd, PO Bx 21, B-1050 07
0123-CPD-0456 EN 14843 Precast concrete stairs External stairs Concrete : Compressive strength $f_{ck} =$ xx N/mm ² Reinforcing steel : Ultimate tensile strength $f_{tk} =$ yyy N/mm ² Tensile yield strength $f_{yk} =$ zzz N/mm ² Prestressing steel : Ultimate tensile strength $f_{pk} =$ uuu N/mm ² Tensile 0,1 % proof-stress $f_{p0.1k} =$ www N/mm ² For geometrical data, detailing, mechanical strength, fire resistance, airborne sound insulation and durability see the design specifications Design Specification : Order Code xxxxxx

CE conformity marking consisting of the CE symbol given in Directive 93/68/EEC

Identification of the notified body

Name or identifying mark and registered address of the producer

Last two digits of the year in which the marking was affixed

Number of the FPC certificate

Number and title of European Standard concerned

Generic name and intended use

Information on product mandated characteristics including detailing (to be adapted to the specific product by the producer)

Figure ZA.4 — Example of CE marking with Method 3

In addition to any specific information relating to dangerous substances, the product should also be accompanied, when and where required and in the appropriate form, by documentation listing any other legislation on dangerous substances for which compliance is claimed, together with any information required by that legislation.

NOTE 1 European legislation without national derogations need not be mentioned.

NOTE 2 Affixing the CE marking symbol means, if a product is subject to more than one directive that it complies with all applicable directives.

Bibliography

- [1] CIB report N24 [1973] Tolerances on blemishes of concrete International Council for Building Research Studies and Documentation (CIB) : www.CIBworld.nl
- [2] CEN/TR 14862:2004, *Precast concrete products — Full-scale testing requirements in standards on precast concrete products*
- [3] EN 1168, *Precast concrete products — Hollow core slabs*
- [4] EN 14992, *Precast concrete products — Wall elements*

BSI — British Standards Institution

BSI is the independent national body responsible for preparing British Standards. It presents the UK view on standards in Europe and at the international level. It is incorporated by Royal Charter.

Revisions

British Standards are updated by amendment or revision. Users of British Standards should make sure that they possess the latest amendments or editions.

It is the constant aim of BSI to improve the quality of our products and services. We would be grateful if anyone finding an inaccuracy or ambiguity while using this British Standard would inform the Secretary of the technical committee responsible, the identity of which can be found on the inside front cover.
Tel: +44 (0)20 8996 9000. Fax: +44 (0)20 8996 7400.

BSI offers members an individual updating service called PLUS which ensures that subscribers automatically receive the latest editions of standards.

Buying standards

Orders for all BSI, international and foreign standards publications should be addressed to Customer Services. Tel: +44 (0)20 8996 9001.
Fax: +44 (0)20 8996 7001. Email: orders@bsi-global.com. Standards are also available from the BSI website at <http://www.bsi-global.com>.

In response to orders for international standards, it is BSI policy to supply the BSI implementation of those that have been published as British Standards, unless otherwise requested.

Information on standards

BSI provides a wide range of information on national, European and international standards through its Library and its Technical Help to Exporters Service. Various BSI electronic information services are also available which give details on all its products and services. Contact the Information Centre.
Tel: +44 (0)20 8996 7111. Fax: +44 (0)20 8996 7048. Email: info@bsi-global.com.

Subscribing members of BSI are kept up to date with standards developments and receive substantial discounts on the purchase price of standards. For details of these and other benefits contact Membership Administration.
Tel: +44 (0)20 8996 7002. Fax: +44 (0)20 8996 7001.
Email: membership@bsi-global.com.

Information regarding online access to British Standards via British Standards Online can be found at <http://www.bsi-global.com/bsonline>.

Further information about BSI is available on the BSI website at <http://www.bsi-global.com>.

Copyright

Copyright subsists in all BSI publications. BSI also holds the copyright, in the UK, of the publications of the international standardization bodies. Except as permitted under the Copyright, Designs and Patents Act 1988 no extract may be reproduced, stored in a retrieval system or transmitted in any form or by any means – electronic, photocopying, recording or otherwise – without prior written permission from BSI.

This does not preclude the free use, in the course of implementing the standard, of necessary details such as symbols, and size, type or grade designations. If these details are to be used for any other purpose than implementation then the prior written permission of BSI must be obtained.

Details and advice can be obtained from the Copyright & Licensing Manager.
Tel: +44 (0)20 8996 7070. Fax: +44 (0)20 8996 7553.
Email: copyright@bsi-global.com.