

# Thermoplastics inspection chamber and manhole bases — Test methods for buckling resistance

The European Standard EN 14830:2006 has the status of a  
British Standard

ICS 93.025; 93.030

## National foreword

This British Standard was published by BSI. It is the UK implementation of EN 14830:2006.

The UK participation in its preparation was entrusted by Technical Committee PRI/88, Plastics piping systems, to Subcommittee PRI/88/1, Plastics piping for non-pressure applications.

A list of organizations represented on PRI/88/1 can be obtained on request to its secretary.

This publication does not purport to include all the necessary provisions of a contract. Users are responsible for its correct application.

**Compliance with a British Standard cannot confer immunity from legal obligations.**

This British Standard was published under the authority of the Standards Policy and Strategy Committee on 30 November 2006

© BSI 2006

ISBN 0 580 49532 9

### Amendments issued since publication

Amd. No.	Date	Comments

ICS 93.025; 93.030

English Version

## Thermoplastics inspection chamber and manhole bases - Test methods for buckling resistance

Éléments de fond de boîtes d'inspection et de branchement  
et de regards en thermoplastique - Méthodes d'essai de  
résistance au flambage

Böden von Kontroll- und Einsteigschächten aus  
thermoplastischen Kunststoffen - Prüfverfahren für die  
Widerstandsfähigkeit gegen Einbeulen

This European Standard was approved by CEN on 28 August 2006.

CEN members are bound to comply with the CEN/CENELEC Internal Regulations which stipulate the conditions for giving this European Standard the status of a national standard without any alteration. Up-to-date lists and bibliographical references concerning such national standards may be obtained on application to the Central Secretariat or to any CEN member.

This European Standard exists in three official versions (English, French, German). A version in any other language made by translation under the responsibility of a CEN member into its own language and notified to the Central Secretariat has the same status as the official versions.

CEN members are the national standards bodies of Austria, Belgium, Cyprus, Czech Republic, Denmark, Estonia, Finland, France, Germany, Greece, Hungary, Iceland, Ireland, Italy, Latvia, Lithuania, Luxembourg, Malta, Netherlands, Norway, Poland, Portugal, Romania, Slovakia, Slovenia, Spain, Sweden, Switzerland and United Kingdom.



EUROPEAN COMMITTEE FOR STANDARDIZATION  
COMITÉ EUROPÉEN DE NORMALISATION  
EUROPÄISCHES KOMITEE FÜR NORMUNG

Management Centre: rue de Stassart, 36 B-1050 Brussels

**Contents**

Page

<b>Foreword</b> .....	<b>3</b>
<b>1 Scope</b> .....	<b>4</b>
<b>2 Normative references</b> .....	<b>4</b>
<b>3 Terms and definitions</b> .....	<b>4</b>
<b>4 Principle</b> .....	<b>4</b>
<b>5 Apparatus</b> .....	<b>5</b>
<b>6 Conditioning</b> .....	<b>6</b>
<b>7 Test environment</b> .....	<b>6</b>
<b>8 Procedure</b> .....	<b>6</b>
<b>8.1 Internal negative pressure testing using a free standing test assembly</b> .....	<b>6</b>
<b>8.2 Internal negative pressure testing using a soil box</b> .....	<b>8</b>
<b>8.3 External pressure testing with the assembly submerged in a water tank</b> .....	<b>9</b>
<b>8.4 Evaluation</b> .....	<b>10</b>
<b>9 Test report</b> .....	<b>11</b>
<b>Bibliography</b> .....	<b>13</b>

## Foreword

This European Standard (EN 14830:2006) has been prepared by Technical Committee CEN/TC 155 "Plastics piping systems and ducting systems", the secretariat of which is held by NEN.

This European Standard shall be given the status of a national standard, either by publication of an identical text or by endorsement, at the latest by April 2007, and conflicting national standards shall be withdrawn at the latest by April 2007.

The relevant performance requirements are contained within the referring standard(s) concerned.

This European Standard is one of a series of standards on test methods that support System Standards for plastics piping systems and ducting systems.

According to the CEN/CENELEC Internal Regulations, the national standards organizations of the following countries are bound to implement this European Standard: Austria, Belgium, Cyprus, Czech Republic, Denmark, Estonia, Finland, France, Germany, Greece, Hungary, Iceland, Ireland, Italy, Latvia, Lithuania, Luxembourg, Malta, Netherlands, Norway, Poland, Portugal, Romania, Slovakia, Slovenia, Spain, Sweden, Switzerland and United Kingdom.

## 1 Scope

This European Standard specifies methods of test for the resistance of the base of thermoplastics inspection chambers and manholes to external soil and ground-water pressure after installation.

NOTE This is intended as a test of the durability and structural integrity of manhole and inspection chamber bases supporting product standards prEN 13598-2 [1] and prEN 15229 [2].

## 2 Normative references

The following referenced documents are indispensable for the application of this document. For dated references, only the edition cited applies. For undated references, the latest edition of the referenced document (including any amendments) applies.

ENV 1046:2001, *Plastics piping and ducting systems — Systems outside building structures for the conveyance of water or sewage — Practices for installation above and below ground*

EN ISO 9967:1995, *Thermoplastics pipes — Determination of creep ratio (ISO 9967:1994)*

## 3 Terms and definitions

For the purposes of this document, the following terms and definitions apply.

**3.1 inspection chamber**  
drainage or sewerage fitting used for the to connection of drainage or sewerage installations and/or for changing the direction of drainage or sewerage runs. An inspection chamber terminates at ground level, permitting the introduction of cleaning, inspection and test equipment and the removal of debris but it does not provide access for personnel. The riser shaft connected to these fittings has a minimum outer diameter of 200 mm and a maximum inside diameter of less than 800 mm (see also EN 476:1997 [3] for non circular chambers)

NOTE The termination at ground level permits the introduction of cleaning, inspection and test equipment and the removal of debris but does not provide access for personnel.

**3.2 manhole**  
drainage or sewerage fitting used for the connection of drainage or sewerage installations and/or for changing the direction of drainage or sewerage runs. A manhole terminates at ground level, permitting the introduction of cleaning, inspection and test equipment and the removal of debris and also providing access for personnel. The minimum inside diameter of a manhole riser shaft is 800 mm (see also EN 476:1997 [3] for non circular manholes)

NOTE The termination at ground level permits the introduction of cleaning, inspection and test equipment and the removal of debris and provides access for personnel.

## 4 Principle

A sealed test assembly comprising an inspection chamber or manhole base with a minimum height of 300 mm above the top of the main channel, is placed free standing, or buried in a test box on a 100 mm sand or granular bed and covered with granular backfill to a level of minimum 300 mm above the top of the outlets and inlets of the main channel(s). In some cases the first section of the riser may be required in order to achieve the minimum height of 300 mm.

The assembly is then subjected to a constant internal negative pressure, specified by the product or system standard, for a specified time at a temperature of between 15 °C and 25 °C or as otherwise specified in the product standard.

Alternatively, the pressure difference can be achieved by exposing the test assembly to a constant positive external hydrostatic pressure of the same numeric value as that specified by the product or system standard. The assembly is submerged under water in a closed tank for a specified time at a temperature of between 15 °C and 25 °C or as otherwise specified in the product standard.

During the test the assembly may be monitored by measuring increasing deflections with time as defined in the product standard.

At the end of the test the chamber base/manhole is visually checked for cracking or other defects likely to impair the performance of the inspection chamber or manhole.

## 5 Apparatus

**5.1 Test box**, large enough to accommodate the test assembly including the first 300 mm of riser shaft above the top of the outlet and inlets of the main channel, such that at each side there is a free space of 300 mm minimum between the test assembly and the side/top of the test box.

**5.2 Backfill material**, to cover the test assembly in the box, conforming to Annex A of ENV 1046:2001. Backfill material shall be in accordance with the minimum specification of the manufacturer.

**5.3 Sealable water tank or pressure vessel**, with internal dimensions capable of accommodating the test assembly to ensure all-round clearance and a lockable lid allowing access to the open top of the inspection chamber or manhole. The water tank or pressure vessel shall be such that the test assembly is not able to gain support from the sides or base of the tank or vessel.

It is essential that the removable cover of the tank is designed in such a way that there is a watertight connection between the cover and the open top of the chamber/manhole shaft or base, and that there is an opening big enough for visual inspection inside the chamber or manhole.

The temperature of the water applied shall be  $(20 \pm 2)$  °C or as otherwise specified in the product standard.

**5.4 End closures**, to seal any open pipe socket(s), spigot(s) and additionally, the riser shaft. When testing for structural integrity (20 °C) then the end closures shall be created using standard pipes with end caps. If testing for durability at higher temperatures then plates welded to the end of the sockets or spigots may be used to seal the pipe connections.

**5.5 Pressure or vacuum source**, capable of applying and maintaining the test pressure specified in the product standard specification for the inspection chamber or manhole base as being the maximum pressure that the inspection chamber or manhole base shall be able to withstand (subject to a minimum of  $-0,02$  MPa).

**5.6 Pressure measuring devices**, capable of measuring the internal negative or external water test pressure to within an accuracy of  $\pm 2$  %.

**5.7 Thermometer**, capable of measuring the temperature of the medium surrounding the test assembly to an accuracy of  $\pm 0,5$  °C.

**5.8 Deflection measuring equipment (optional)**, capable of measuring the deflection of the main channel to within an accuracy of  $\pm 0,1$  mm. (If required by the product standard.)

**5.9 Test assembly**, comprising the base and a portion of the riser if required to ensure a height of at least 300 mm above the top of the main channel. Unless otherwise specified in the product standard, one test assembly shall be prepared for each test carried out.

NOTE The preferred configuration for testing the inspection chamber/manhole base is the straight through configuration without side entries.

## 6 Conditioning

Unless otherwise specified in the product standard, the test piece shall be tested no less than 21 days after manufacture and after conditioning in air for at least 6 h at a temperature of between 15 °C and 25 °C.

## 7 Test environment

Unless otherwise specified in the product standard, testing shall be carried out at a temperature of between 15 °C and 25 °C.

## 8 Procedure

### 8.1 Internal negative pressure testing using a free standing test assembly

**8.1.1** Seal all inlets and outlets of the test assembly and the top of the riser shaft using the end closures.

NOTE 1 Internal or external tie bars may be used between the inlet and outlet closures to avoid the transmission of external end loading forces to the inspection chamber/manhole base via the end closures.

NOTE 2 The test assembly may be turned 180° upside down to simplify the test.

If the base is designed with a double wall, where the outer wall is designed to withstand upthrust, one or more 3 mm to 4 mm diameter holes shall be drilled through the inner wall to ensure that the internal negative pressure is loaded against the outside wall of the base assembly.

**8.1.2** If the measurement of deflection is required by the product standard install the two devices for measuring deflection at points “W” and “H” as shown in Figures 1 and 2.

In the case where bases are non-spherical the relative vertical deformation of the base can be measured directly from a datum provided by a stiff beam connected at points  $H_L$  and  $H_R$ .

If a separate datum is used the points  $H_L$ ,  $H_R$  and  $H_M$  shall be measured from that datum during the test and the final deflection expressed as  $Y_V$  where  $Y_V = ((H_L + H_R)/2) - H_M$ .

The change of the width of the main channel shall be expressed as  $Y_H$  where this is the change to dimension “W”.

The sample shall be visibly inspected for evidence of cracks after completion of the test.



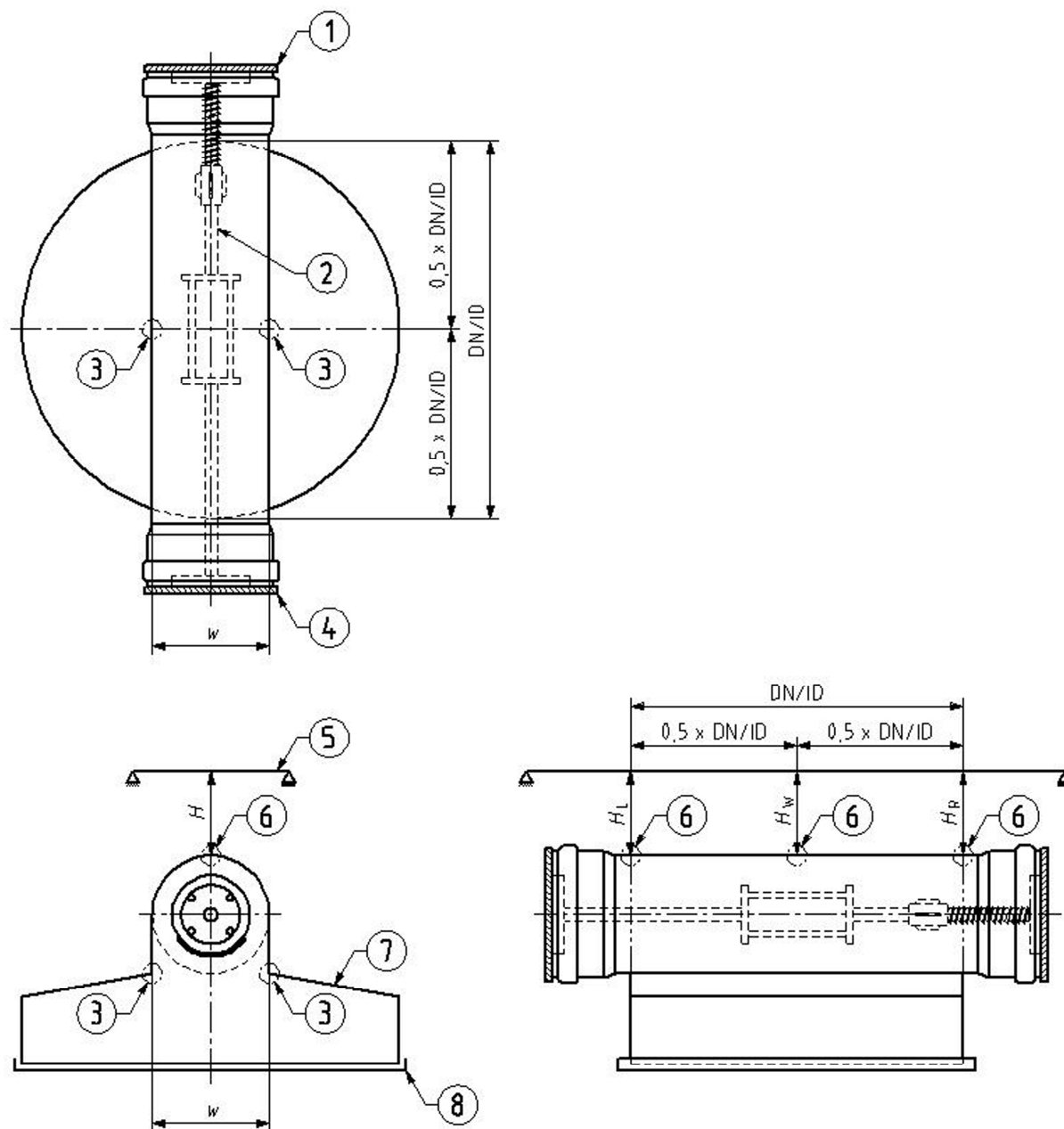

**Key**

- |   |                                    |   |                                    |
|---|------------------------------------|---|------------------------------------|
| 1 | plug-inlet                         | 5 | reference                          |
| 2 | plug support device                | 6 | measuring points for dimension $H$ |
| 3 | measuring points for dimension $w$ | 7 | base section                       |
| 4 | plug-outlet                        | 8 | removable cover                    |

**Figure 1 — Position of measuring devices in the main channel**

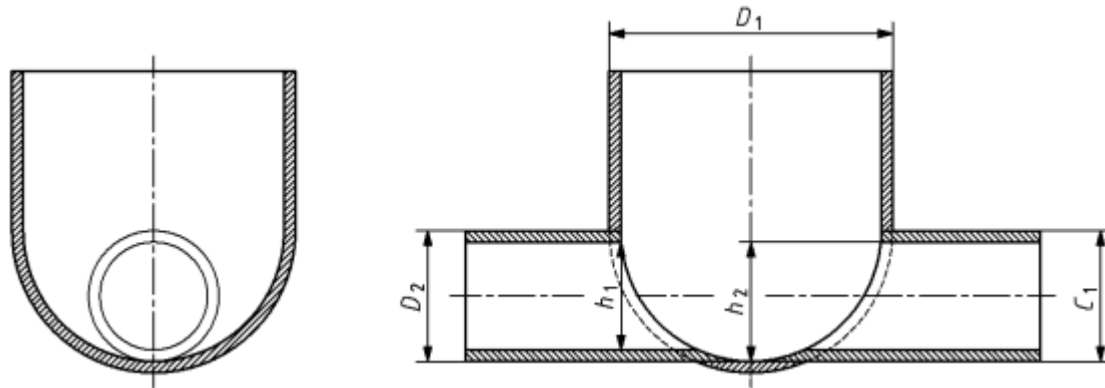
**Key**

- $D_1$  chamber diameter
- $D_2$  outlet connection diameter
- $C_1$  diameter of connection 1
- $h_1$  measure height at point 1, which points are located at inlet and outlet
- $h_2$  measure height at point at the middle of the base

**Figure 2 — Position of measuring devices for spherical bases**

**8.1.3** Connect the pressure source and pressure-measuring device to the test assembly and apply the internal negative pressure (see 5.5), maintaining it at between 15 °C to 25 °C or at the temperature specified in the product standard for a minimum of 1 000 h or for the time specified in the referring standard for the inspection chamber or manhole base within a tolerance of  $\pm 2\%$ . If deflection measurements are required by the product standard these shall be taken at the required defined intervals throughout the test.

## 8.2 Internal negative pressure testing using a test box

Prepare the test assembly as described in 8.1.1. Place the test assembly on a  $(100 \pm 10)$  mm thick granular bed, in the position in which it would be installed, see Figure 3. Apply the backfill and compact to the minimum specified in the manufacturer's documentation, see 5.2. Connect and apply the test pressure as described in 8.1.3.

Dimensions in millimetres

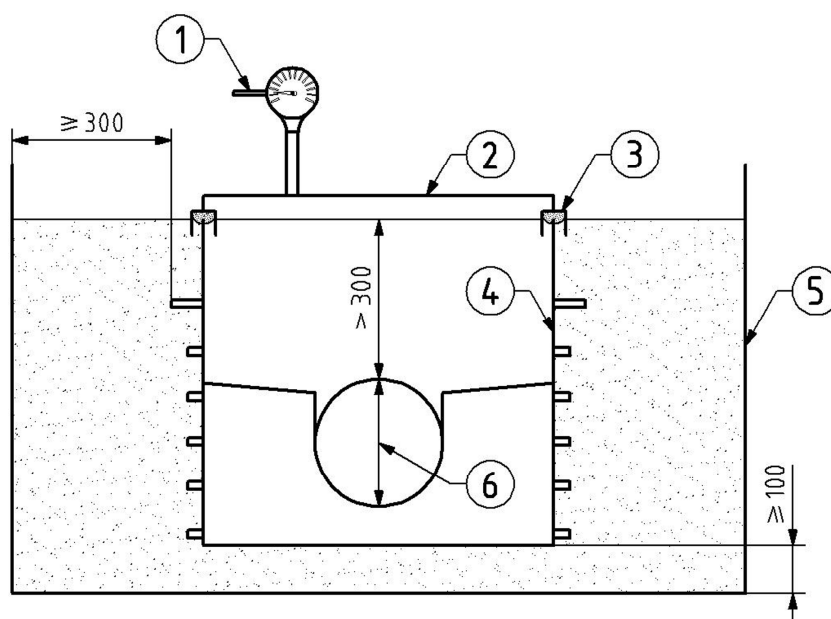
**Key**

- 1 vacuum source
- 2 cover
- 3 seal

- 4 base-component
- 5 tank/test box
- 6 maximum DN

**Figure 3 — Test set up when testing in a test box**

### 8.3 External pressure testing with the assembly submerged in a water tank

Prepare the test assembly as described in 8.1.1.

It is permitted to cut back the riser shaft to a height of 300 mm above the top of the outlets and inlets of the main channel(s).

Place the assembly in the water tank and fill the annular space between tank and assembly with water. Lock the lid of the tank in position leaving access to the open top of the inspection chamber or manhole. See Figure 4.

Connect a pressure source and pressure-measuring device to the tank, apply the external test pressure (see 5.5) and maintain the pressure for the duration of the test, within a tolerance of  $\pm 2\%$ .

Dimensions in millimetres

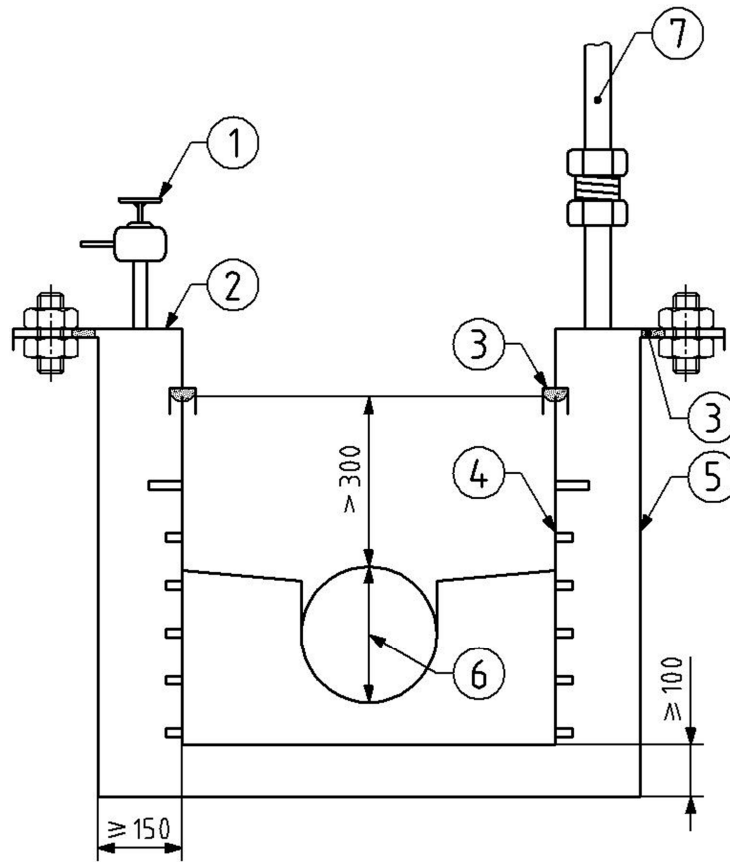

**Key**

- |   |                |   |            |
|---|----------------|---|------------|
| 1 | vent valve     | 5 | tank       |
| 2 | cover          | 6 | maximum DN |
| 3 | seal           | 7 | water hose |
| 4 | base-component |   |            |

**Figure 4 — Test set up of testing in a pressure vessel**

**8.4 Evaluation**

At the end of the test observe the test assembly for any signs of cracking.

If extrapolation of the deflection data is required by the product standard this shall be carried out by the method of least mean squares as generally described in EN ISO 9967 to 50 year time period as required, unless otherwise specified in the referring product standard.

NOTE Informative Annex A shows an example evaluation using the method of least mean squares.

## 9 Test report

The test report shall include the following information:

- a) reference to this European Standard, i.e. EN 14830 and the referring standard for the inspection chamber or manhole base;
- b) identification of the inspection chamber or manhole, including the nominal size(s) of the main channel(s);
- c) test procedure used and the soil type used if testing with the test box;
- d) test pressure applied;
- e) test temperature;
- f) test duration time;
- g) if required by the referring standard, deflections generated at the end of the test or the predicted 50 year deflections as specified;
- h) visible crack(s);
- i) any factors noted during the test procedure that might have affected the test result, such as any incidents or operating details not covered in this document;
- j) date of the test.

## Annex A (informative)

### Example evaluation

Table A 1 — Example evaluation

Interval	$T$ (h)	$x = \log t$	Deformation (mm)	Dataset	Trendline	$R$	1 000 h prediction (mm)
t1	0,1	-1	0,83	t1 to t11	$y = 0,575\ 3x + 1,099\ 5$	0,967 4	2,83
t2	1	0	1,08	t2 to t11	$y = 0,667\ 7x + 0,875$	0,974 7	2,88
t3	4	0,602 1	1,27	t3 to t11	$y = 0,756\ 9x + 0,644\ 1$	0,976 4	2,92
t4	24	1,380 2	1,58	t4 to t11	$y = 0,923\ 5x + 0,198\ 2$	0,981 9	2,97
t5	168	2,225 3	2,09	t5 to t11	$y = 1,258\ 1x - 0,726\ 1$	0,998 4	3,05
t6	336	2,526 3	2,45	t6 to t11	$y = 1,322\ 3x - 0,908\ 4$	0,997 7	3,06
t7	504	2,702 4	2,65	t7 to t11	$y = 1,422\ 8x - 1,198\ 8$	0,999	3,07
t8	600	2,778 2	2,75				
t9	696	2,842 6	2,84				
t10	864	2,936 5	2,99				
t11	1 008	3,003 5	3,07				

The trendline ( $y = 1,422\ 8 \times x - 1,198\ 8$ ) shows the best prediction for the 1 000 h value and hence used for the prediction of the deformation after 50 years. If extended testing is required to generate an  $R$  correlation  $> 0,9$  then the additional testing intervals beyond 1 000 h shall be as those specified in 8.3 of EN ISO 9967:1995.

## Bibliography

- [1] prEN 13598-2, *Plastics piping systems for non-pressure underground drainage and sewerage — Unplasticized poly(vinyl chloride) (PVC-U), polypropylene (PP) and polyethylene (PE) — Part 2: Specifications for manholes and inspection chambers in traffic areas and deep underground installations*
- [2] prEN 15229, *Plastics piping systems — Piping systems for non-pressure underground drainage and sewerage — Performance requirements for thermoplastics manholes and inspection chambers*
- [3] EN 476:1997, *General requirements for components used in discharge pipes, drains and sewers for gravity systems*

---

---

# BSI — British Standards Institution

BSI is the independent national body responsible for preparing British Standards. It presents the UK view on standards in Europe and at the international level. It is incorporated by Royal Charter.

## Revisions

British Standards are updated by amendment or revision. Users of British Standards should make sure that they possess the latest amendments or editions.

It is the constant aim of BSI to improve the quality of our products and services. We would be grateful if anyone finding an inaccuracy or ambiguity while using this British Standard would inform the Secretary of the technical committee responsible, the identity of which can be found on the inside front cover.  
Tel: +44 (0)20 8996 9000. Fax: +44 (0)20 8996 7400.

BSI offers members an individual updating service called PLUS which ensures that subscribers automatically receive the latest editions of standards.

## Buying standards

Orders for all BSI, international and foreign standards publications should be addressed to Customer Services. Tel: +44 (0)20 8996 9001.  
Fax: +44 (0)20 8996 7001. Email: [orders@bsi-global.com](mailto:orders@bsi-global.com). Standards are also available from the BSI website at <http://www.bsi-global.com>.

In response to orders for international standards, it is BSI policy to supply the BSI implementation of those that have been published as British Standards, unless otherwise requested.

## Information on standards

BSI provides a wide range of information on national, European and international standards through its Library and its Technical Help to Exporters Service. Various BSI electronic information services are also available which give details on all its products and services. Contact the Information Centre.  
Tel: +44 (0)20 8996 7111. Fax: +44 (0)20 8996 7048. Email: [info@bsi-global.com](mailto:info@bsi-global.com).

Subscribing members of BSI are kept up to date with standards developments and receive substantial discounts on the purchase price of standards. For details of these and other benefits contact Membership Administration.  
Tel: +44 (0)20 8996 7002. Fax: +44 (0)20 8996 7001.  
Email: [membership@bsi-global.com](mailto:membership@bsi-global.com).

Information regarding online access to British Standards via British Standards Online can be found at <http://www.bsi-global.com/bsonline>.

Further information about BSI is available on the BSI website at <http://www.bsi-global.com>.

## Copyright

Copyright subsists in all BSI publications. BSI also holds the copyright, in the UK, of the publications of the international standardization bodies. Except as permitted under the Copyright, Designs and Patents Act 1988 no extract may be reproduced, stored in a retrieval system or transmitted in any form or by any means – electronic, photocopying, recording or otherwise – without prior written permission from BSI.

This does not preclude the free use, in the course of implementing the standard, of necessary details such as symbols, and size, type or grade designations. If these details are to be used for any other purpose than implementation then the prior written permission of BSI must be obtained.

Details and advice can be obtained from the Copyright & Licensing Manager.  
Tel: +44 (0)20 8996 7070. Fax: +44 (0)20 8996 7553.  
Email: [copyright@bsi-global.com](mailto:copyright@bsi-global.com).