

Railway applications — Air conditioning for driving cabs —

Part 2: Type tests

The European Standard EN 14813-2:2006 has the status of a British Standard

ICS 45.060.10

National foreword

This British Standard is the official English language version of EN 14813-2:2006.

The UK participation in its preparation was entrusted by Technical Committee RAE/1, Railway applications, to Subcommittee RAE/1/-/6, Air conditioning, heating and ventilation, which has the responsibility to:

- aid enquirers to understand the text;
- present to the responsible international/European committee any enquiries on the interpretation, or proposals for change, and keep UK interests informed;
- monitor related international and European developments and promulgate them in the UK.

A list of organizations represented on this subcommittee can be obtained on request to its secretary.

Cross-references

The British Standards which implement international or European publications referred to in this document may be found in the *BSI Catalogue* under the section entitled “International Standards Correspondence Index”, or by using the “Search” facility of the *BSI Electronic Catalogue* or of British Standards Online.

This publication does not purport to include all the necessary provisions of a contract. Users are responsible for its correct application.

Compliance with a British Standard does not of itself confer immunity from legal obligations.

Summary of pages

This document comprises a front cover, an inside front cover, the EN title page, pages 2 to 27 and a back cover.

The BSI copyright notice displayed in this document indicates when the document was last issued.

This British Standard was published under the authority of the Standards Policy and Strategy Committee on 31 August 2006

© BSI 2006

ISBN 0 580 48798 9

Amendments issued since publication

Amd. No.	Date	Comments

ICS 45.060.10

English Version

Railway applications - Air conditioning for driving cabs - Part 2: Type tests

Applications ferroviaires - Conditionnement de l'air pour
cabines de conduite - Partie 2: Essais de type

Bahnanwendungen - Luftbehandlung in Führerräumen -
Teil 2: Typprüfungen

This European Standard was approved by CEN on 26 June 2006.

CEN members are bound to comply with the CEN/CENELEC Internal Regulations which stipulate the conditions for giving this European Standard the status of a national standard without any alteration. Up-to-date lists and bibliographical references concerning such national standards may be obtained on application to the Central Secretariat or to any CEN member.

This European Standard exists in three official versions (English, French, German). A version in any other language made by translation under the responsibility of a CEN member into its own language and notified to the Central Secretariat has the same status as the official versions.

CEN members are the national standards bodies of Austria, Belgium, Cyprus, Czech Republic, Denmark, Estonia, Finland, France, Germany, Greece, Hungary, Iceland, Ireland, Italy, Latvia, Lithuania, Luxembourg, Malta, Netherlands, Norway, Poland, Portugal, Romania, Slovakia, Slovenia, Spain, Sweden, Switzerland and United Kingdom.



EUROPEAN COMMITTEE FOR STANDARDIZATION
COMITÉ EUROPÉEN DE NORMALISATION
EUROPÄISCHES KOMITEE FÜR NORMUNG

Management Centre: rue de Stassart, 36 B-1050 Brussels

Contents

Page

Foreword.....	4
Introduction	5
1 Scope	6
2 Normative references	6
3 Terms and definitions	6
4 Test classification.....	6
5 Preliminary verifications	7
6 Comfort tests.....	7
6.1 Air movement tests.....	7
6.1.1 General remarks.....	7
6.1.2 Air flow rates	7
6.1.3 Pressure differentials (visualisation).....	7
6.2 Measurement of air speeds	7
6.3 Thermal comfort.....	7
7 Climatic tests.....	8
7.1 General remarks.....	8
7.2 Preheating test	8
7.2.1 Test level TL1	8
7.2.2 Test level TL2	8
7.3 Precooling test	8
7.3.1 Test level TL1	8
7.3.2 Test level TL2	8
7.4 Regulation test.....	9
8 Tests at extreme exterior operating conditions	9
9 Complementary tests	9
9.1 Determination of the coefficient k	9
9.1.1 Purpose of the test	9
9.1.2 Definition	9
9.1.3 Procedure	9
9.2 Thermography.....	10
9.3 Noise emission.....	10
9.4 Vibration generation.....	10
10 Methods of measurement – Measuring instruments	10
10.1 General remark.....	10
10.2 Temperatures	10
10.2.1 Air temperature	10

10.2.2	Surface temperatures.....	10
10.3	Relative humidity.....	11
10.4	Air speed	11
10.5	Airflow rate	11
10.6	Simulated speed of the vehicle.....	11
10.7	Equivalent solar load	11
10.8	Energy consumption and power rating.....	11
11	Characteristics of the test equipment.....	11
11.1	General remarks	11
11.2	Occupation	11
11.3	Equivalent solar load	12
11.3.1	General	12
11.3.2	Solar load calculation	12
11.3.3	Front window area.....	13
11.3.4	Wall area.....	13
11.3.5	Roof area	13
12	Distribution of measuring points.....	14
12.1	General	14
12.2	Measuring points in the driving cab.....	14
12.3	Climatic chamber sensor distribution.....	14
Annex A (normative)	Test programme for TL1.....	15
Annex B (normative)	Test programme for TL2.....	17
Annex C (normative)	Equivalent solar load	23
Annex D (normative)	Location of the measuring points in a driving cab.....	24
Annex E (normative)	Location of the temperature sensors in the test chamber.....	26
Annex ZA (informative)	Relationship between this European Standard and the Essential Requirements of EU Directive 96/48/EC.....	27

Foreword

This document (EN 14813-2:2006) has been prepared by Technical Committee CEN/TC 256 "Railway applications", the secretariat of which is held by DIN.

This European Standard shall be given the status of a national standard, either by publication of an identical text or by endorsement, at the latest by February 2007, and conflicting national standards shall be withdrawn at the latest by February 2007.

This document has been prepared under a mandate given to CEN by the European Commission and the European Free Trade Association, and supports essential requirements of EU Directive 96/48/EC.¹⁾

For relationship with the EU Directive, see informative Annex ZA, which is an integral part of this document.

This series of European Standard includes the following parts:

- EN 14813-1, *Railway applications — Air conditioning for driving cabs — Part 1: Comfort parameters*
- EN 14813-2, *Railway applications — Air conditioning for driving cabs — Part 2: Type tests*

In the context of this series, there are two further series on air conditioning in rolling stock:

- EN 13129-1, *Railway applications — Air conditioning for main line rolling stock — Part 1: Comfort parameters*
- EN 13129-2, *Railway applications — Air conditioning for main line rolling stock — Part 2: Type tests*
- EN 14750-1 *Railway applications — Air conditioning for urban and suburban rolling stock — Part 1: Comfort parameters*
- EN 14750-2 *Railway applications — Air conditioning for urban and suburban rolling stock — Part 2: Type tests*

According to the CEN/CENELEC Internal Regulations, the national standards organizations of the following countries are bound to implement this European Standard: Austria, Belgium, Cyprus, Czech Republic, Denmark, Estonia, Finland, France, Germany, Greece, Hungary, Iceland, Ireland, Italy, Latvia, Lithuania, Luxembourg, Malta, Netherlands, Norway, Poland, Portugal, Romania, Slovakia, Slovenia, Spain, Sweden, Switzerland and United Kingdom.

1) Official Journal No L 235 of 17.9.1996. Amended by Directive 2004/50/EC of the European Parliament and of the Council of 29 April 2004, Official Journal No L 164 of 30.4.2004.

Introduction

The object of this European Standard is to establish programmes and test methods to verify the air conditioning installations as described in EN 14813-1.

If necessary, the revised requirements due to operating constraints of the vehicle will be detailed in the contractual specification. This European Standard applies if there is no particular clause in the contractual specification.

1 Scope

This European Standard is applicable to railway vehicle driving cabs which are air-conditioned or heated/ventilated. These include:

- locomotives;
- mainline, suburban or regional vehicles;
- urban vehicles such as metros and trams.

This European Standard does not consider the special operational requirements of shunt locomotives.

This European Standard specifies the comfort parameter measurement methods for driving cabs.

The comfort parameters and their tolerances cited in this European Standard are defined in EN 14813-1.

2 Normative references

The following referenced documents are indispensable for the application of this document. For dated references, only the edition cited applies. For undated references, the latest edition of the referenced document (including any amendments) applies.

EN 14813-1:2006, *Railway applications — Air conditioning for driving cabs — Part 1: Comfort parameters*

EN ISO 3381, *Railway applications — Acoustics — Measurement of noise inside railbound vehicles (ISO 3381:2005)*

EN ISO 7726:2001, *Ergonomics of the thermal environment — Instruments for measuring physical quantities (ISO 7726:1998)*

CIE 85, *Solar spectral irradiance*²⁾

3 Terms and definitions

For the purposes of this document, the terms and definitions given in EN 14813-1:2006 apply.

4 Test classification

Two levels of testing are detailed in this European Standard.

TL1 is a simplified level that gives principle information about the functionality of the system. It does not aim to verify the comfort parameters and performance of the system. It can be done in a workshop or at a yard. TL2 is a full level test to verify the comfort parameters and the performance of the system. This test shall be performed in a climatic chamber or in an appropriate environment.

The operator shall detail in his contractual specification the test classification.

²⁾ To be purchased from: International Commission of Illumination, CIE Central Bureau, Kegelgasse 27, A-1030 Wien.

In the absence of any detail, the full level of testing (TL2) shall apply. If not stated otherwise, the following test requirements apply to both TL1 and TL2.

5 Preliminary verifications

It is advised that preliminary tests are carried out to verify the electrical and electronic assemblies, the functional logic of the control system, the air tightness of the air distribution system, the water tightness of the car, the thermal capacity of the air conditioning equipment and so on. These verifications should be conducted before proceeding to the comfort test.

6 Comfort tests

6.1 Air movement tests³⁾

6.1.1 General remarks

The tests shall be carried out under the following conditions:

- vehicle stationary and protected from rain;
- altitude < 1 000 m above sea level;
- exterior air speed between 0 km/h and 5 km/h;
- exterior temperature between + 15 °C and + 30 °C.

In the case of different altitude and exterior temperature, correction shall be made.

6.1.2 Air flow rates

The flow rates of outside air (fresh air) shall be measured in accordance with 10.5.

6.1.3 Pressure differentials (visualisation)

If appropriate, this can be shown up by the movement of smoke between the two relative areas.

The visualisation shall be made for driving cabs to verify that the air conditioning installation is well designed by preventing the transfer of smoke to a non-smoking area.

6.2 Measurement of air speeds

These tests shall be carried out during the climatic tests without the simulation of the thermal and volumetric effects of occupation (the necessary heating elements, humidification and ventilation equipment can affect the measurement inside the comfort envelope). Measuring points shall be according to Annex D.

6.3 Thermal comfort

It is recommended for a detail analysis of thermal comfort to use thermal mannequins.

³⁾ This is applicable for TL1 and TL2.

7 Climatic tests

7.1 General remarks

Annex A defines the test programme for level TL1. These tests are only carried out on a stationary vehicle at air speed as defined in Annex A.

Annex B defines a minimum schedule of tests for level TL2 which enables the verification of comfort parameters defined in EN 14813-1. The order of the tests is not obligatory but shall be compatible with the physical conditions of the test and the means of measurement.

Throughout the tests, all the values at the measuring points defined in Clause 11 shall be recorded continuously, as well as the energy consumption and the power absorbed by the air conditioning installation itself, and the whole of the vehicle.

Should other requirements such as for example the doors, the power supply, the lighting etc., need to be tested, these tests shall not interfere in any way with the tests on the air conditioning equipment installed.

7.2 Preheating test

7.2.1 Test level TL1

The test conditions for preheating are defined in Annex A.

Before the start of the preheating test, the interior temperatures of the air and the interior surfaces shall be within ± 2 K of the exterior air temperature for at least 15 min.

It is anticipated that the temperature stabilisation process may take up to 8 h.

7.2.2 Test level TL2

The test conditions for preheating are defined in Annex B.

Before the start of the preheating test, the interior temperatures of the air and the interior surfaces shall be within ± 1 K of the exterior air temperature for at least 15 min.

7.3 Precooling test

7.3.1 Test level TL1

The test conditions for precooling are defined in Annex A.

Before the start of the precooling test, the interior temperatures of the air and the interior surfaces shall be within ± 2 K of the exterior air temperature for at least 15 min.

At this time, before starting the precooling test, the artificial sunlight equipment or equivalent heating power shall be switched on for 2 h, corresponding to the values given in Annex D of EN 14813-1:2006, with doors and windows closed.

7.3.2 Test level TL2

The test conditions for precooling are defined in Annex B.

Before the start of the precooling test, the interior temperatures of the air and the interior surfaces shall be within ± 1 K of the exterior air temperature for at least 15 min.

At this time, before starting the precooling test, the artificial sunlight equipment or equivalent heating power shall be switched on for 2 h, corresponding to the values given in Annex D of EN 14813-1:2006, with all doors and windows closed.

7.4 Regulation test

The test conditions are defined in Annex A and Annex B.

Starting from stabilised operation (see EN 14813-1:2006, 3.34), after a changing of a parameter (interior or exterior), wait 60 min or three similar consecutive control cycles, then the results obtained shall be in accordance with the requirements defined in EN 14813-1.

8 Tests at extreme exterior operating conditions

The operation of the air conditioning equipment, when installed on the vehicle, shall be checked at the extreme operating temperatures defined in EN 14813-1:2006, 6.3.

For TL1, these tests may be carried out on the air conditioning equipment only.

9 Complementary tests

9.1 Determination of the coefficient k

9.1.1 Purpose of the test

The coefficient k characterises the thermal quality of a driving cab (efficiency of the insulation). The test shall be carried out only at TL2. The test conditions are defined in Annex B.

9.1.2 Definition

The global coefficient k is defined by the following equation:

$$k = \frac{P}{A_e \times (T_{im} - T_{em})}$$

where

- the surface A_e is the developed exterior surface of the assembly including walls, ceiling, floor and ends of the structure for all or part of the driving cab under consideration. This shall include windows, doors and openings;
- P is the thermal power released inside the driving cab, necessary to maintain constantly the difference in absolute value between the interior temperature (T_{im}) measured at 0,8 m above the seat reference point according to Annex D, and the mean exterior temperature (T_{em}).

9.1.3 Procedure

The openings for fresh air and exhaust air are sealed, but not insulated.

The air conditioning installation is isolated. The vehicle is without power (except for the batteries). The doors and the windows are closed.

It is necessary to provide a heating installation independent of that of the cab, controllable to a low output and distributed in the driving cab. The uniformity of the temperatures inside the vehicle shall be achieved by fans. The power consumption of the heaters and the fans shall be recorded separately.

All the measured data shall be recorded at least once per minute.

The value of the temperature difference $|T_{im}-T_{em}|$ shall be $25\text{ K} \pm 5\text{ K}$. It is recommended to carry out this test with $T_{em} = +5\text{ }^{\circ}\text{C} \pm 2\text{ K}$.

The output of the heating system and of the ventilation is maintained constant; the determination of the coefficient k is possible after stabilisation of the temperatures:

- values of T_{em} and $|T_{im}-T_{em}|$ shall be determined and averaged over a period of 30 min. The variation of these values, over a minimum period of 3 h shall be less than 0,1 K;
- range of temperatures relating to different points of measurement (interior and exterior) shall be less than 2 K.

The coefficient k is calculated using the measurements taken during the last hour of stabilisation of temperatures.

9.2 Thermography

The thermographic test is recommended for evaluation of the thermal quality of the vehicle.

9.3 Noise emission

The measurement of noise shall be carried out with the air conditioning installation functioning in the same modes than at the extreme summer temperature of the zone considered in EN 14813-1:2006, Annex D and Annex E, and in accordance with EN ISO 3381.

9.4 Vibration generation

The measurement of vibration shall be carried out on a stationary vehicle with the air conditioning installation functioning at a level which corresponds to the requirements of the contractual specification.

10 Methods of measurement – Measuring instruments

10.1 General remark

Continuous recording should be carried out, taking as a base a minimum of sampling rates of one measurement per minute for all the values recorded.

10.2 Temperatures

10.2.1 Air temperature

The measuring devices shall be class S according to EN ISO 7726:2001, Table 2, and have a maximum drift of $\pm 0,25\text{ K}$ over the duration of recording.

10.2.2 Surface temperatures

In respect of the walls, and in order to measure the real temperature of the relevant surface, precautions shall be taken to protect against external influences such as radiation, convection and transmission of heat.

The class of measuring devices shall be identical to that in 10.2.1.

10.3 Relative humidity

The measuring devices shall be class C according to EN ISO 7726:2001, Table 2.

10.4 Air speed

Continuous recording should be carried out, taking as a base sampling rate of at least one measurement per second for a minimum period of 1 min. For the purpose of quantifying the variations in speed, the calculation of arithmetic averages, as well as that of the standard deviations for that period shall be carried out.

The measuring devices shall be class C of EN ISO 7726:2001, Table 2.

10.5 Airflow rate

The airflow shall be determined using a system of measurement which enables the recording of results with a minimum accuracy of 10 %; it is not necessary to carry out a continuous recording of these measurements. At the same time the exterior temperature and the barometric pressure should be recorded.

10.6 Simulated speed of the vehicle

The speed of the air around the vehicle is determined by a calibrated system of measurement which enables the recording of results with a minimum accuracy of ± 1 m/s.

10.7 Equivalent solar load

The measurement of the equivalent solar load is achieved by a calibrated system of measurement. This measurement is carried out in accordance with the procedure described in Annex C.

10.8 Energy consumption and power rating

The measurements shall be carried out using instruments having an accuracy of within 1 %.

11 Characteristics of the test equipment

11.1 General remarks

If the tests are performed in a climatic chamber, this chamber shall be approved by a certification organisation.

The tolerances of the exterior temperature, exterior relative humidity and exterior air velocity stated in Annex A and Annex B shall be maintained throughout the tests.

11.2 Occupation

The simulation of the occupation, total or partial, of the conditioned space is to be achieved in accordance with the curves of EN 14813-1:2006, Annex C.

For the simulation of the sensible heat, it is necessary to use heating equipment of low radiance whose surface temperature is less than + 40 °C.

The simulation of the latent heat is carried out by the production of water vapour. The sensible heat introduced by the equipment producing the vapour is to be incorporated in the total balance of sensible heat.

11.3 Equivalent solar load

11.3.1 General

If available, the equipment which simulates the equivalent solar load based on the index of terrestrial radiation (global solar load) of 1 120 W/m² in accordance with the CIE 85 shall be composed of lamps whose characteristics comply with Table 1.

Table 1 — Characteristics of solar radiation lamps

Wavelength	Total radiation compared with terrestrial radiation given in CIE 85	Allowable variation
Nanometer	%	%
280 to 400	6,1	± 3
400 to 800	51,8	± 5
800 to 3 000	42,1	± 5

Only for TL1, if solar radiation lamps with the setup according to Annex C are not available, the equivalent solar load may be simulated by the following method:

- external panel of incandescence or halogen lamps, as the preferred solution;
- evenly distributed floor-mounted heating elements within the cab, whose capacity is calculated by the approximate method given in 11.3.2, 11.3.3, 11.3.4 and 11.3.5.

The maximum power of each heating element shall not exceed 500 W.

11.3.2 Solar load calculation

$$Q_S = Q_{S,F} + Q_{S,W} + Q_{S,D}$$

where

Q_S is the total solar load, in W;

$Q_{S,F}$ is the solar load of the window area, in W;

$Q_{S,W}$ is the solar load of the side wall area, in W;

$Q_{S,D}$ is the solar load of the roof area, in W.

11.3.3 Front window area

$$Q_{S,F} = A_F \times d_F \times q_{S,W} = A_F \times d_F \times E_n \times \cos(30^\circ - \beta)$$

where

A_F is the front window area, in m^2 ;

d_F is the overall transmission factor of the windows 0,3 to 0,8;

$q_{S,W}$ is the heat load due to solar radiation on a vertical window, in W/m^2 ;

E_n is the equivalent solar load of the zone in accordance with EN 14813-1:2006, Annex D, in W/m^2 ;

β is the inclination of the front window in relation to the vertical plane as defined in Annex C, in degrees.

11.3.4 Wall area

$$Q_{S,W} = \frac{k_W \times A_W}{\alpha_a} \times \varepsilon \times q_{S,W} = \frac{k_W \times A_W}{9} \times \varepsilon \times E_n \times \cos(30^\circ - \varphi)$$

where

k_W is the k value of the front wall, in W/m^2K ;

A_W is the total surface of front wall excluding front window area, in m^2 ;

α_a is the outside air heat transfer coefficient in stationary condition, in W/m^2K ;

ε is the solar absorption factor 0,5 to 0,8 according to surface finishing;

$q_{S,W}$ is the heat load due to solar radiation on the front wall excluding the front window area, in W/m^2 ;

E_n is the equivalent solar load of the zone in accordance with EN 14813-1:2006, Annex D, in W/m^2 ;

φ is the inclination of the front wall in relation to the vertical plane as defined in Annex C, in degrees.

11.3.5 Roof area

$$Q_{S,D} = \frac{k_D \times A_D}{\alpha_a} \times \varepsilon \times q_{S,D} = \frac{k_D \times A_D}{9} \times \varepsilon \times E_n \times \sin 30^\circ$$

where

k_D is the k value of the roof, in W/m^2K ;

A_D is the total surface of the roof, in m^2 ;

α_a is the outside air heat transfer coefficient in stationary condition, in W/m^2K ;

ε is the solar absorption factor 0,5 to 0,8 according to surface finishing;

$q_{S,D}$ is the heat load due to solar radiation on the roof, in W/m^2 ;

E_n is the equivalent solar load of the zone in accordance with EN 14813-1:2006, Annex D, in W/m^2 .

12 Distribution of measuring points

12.1 General

The measurement point positions are as indicated below. If for physical or environmental reasons it is not possible to measure in the point defined, the measurement point shall be detailed by the contractual specification.

12.2 Measuring points in the driving cab

Annex D shows one typical example of a driving cab with principal positions (standing and seated) of the driver. For the agreed position the measuring points for air velocity, temperature and relative humidity are given.

Before performing climatic tests, the most critical position for the air velocity (tall or small driver) with and without solar load activated shall be decided by checking the different points under all fan speed conditions. During the climatic tests the parameters on the critical position should be measured continuously.

In addition the temperature shall be measured at the hottest point of each accessible air outlet (determined by simple checking).

The range of the interior air temperature in a vertical section of a driver shall use measurements taken between normal head and feet positions as defined in Annex D.

12.3 Climatic chamber sensor distribution

The measurement points of the mean temperature T_{em} , the relative humidity and the air speed are defined in Annex E.

Annex A (normative)

Test programme for TL1

Table AA.1 — Tests in heating mode for TL1

Test	Description of test	Mean exterior temperature (Tem) °C	Relative humidity %	Air speed km/h	Simulation of occupation of the driving cab %	Equivalent solar load %	Interior temperature setting (Tic)		Remarks
							Constant temperature control ^a °C	Selection switch offset ΔT_{ic} ^b K	
TL 110	Preheating	< + 5	–	0 to 15	0	0	+ 22	+ 2	
TL 111	Regulation	< + 5	–	0 to 15	0	0	+ 22	+ 2	
TL 112	Regulation	< + 5	–	0 to 15	0	0	+ 18	- 2	Extreme position
TL 113	Regulation	< + 5	–	0 to 15	0	0	+ 26	+ 4	Extreme position
TL 114	Regulation	< + 5	–	0 to 15	0	0	+ 22	+ 2	Tests with different fan speeds if manual fan control is available ^c
TL 115	Heating performance	< + 5	–	0 to 15	0	0	–	–	Manual control (temperature control override) ^c
TL 116	Extreme condition	Tem1 ^d	–	0 to 15	0	0	–	–	Equipment function check ^e

^a See EN 14813-1:2006, 8.2.2.

^b See EN 14813-1:2006, 8.2.3.

^c Optional.

^d Tem1 = - 15 °C for zone I, Tem1 = - 25 °C for zone II and Tem1 = - 45 °C for zone III.

^e These tests may be carried out on the air conditioning equipment only.

Table AA.2 — Tests in cooling mode for TL1

Test	Description of test	Mean exterior temperature (Tem) ^a °C	Relative humidity %	Air speed km/h	Simulation of occupation of the driving cab %	Equivalent solar load %	Interior temperature setting (Tic)		Remarks
							Constant temperature control ^b °C	Selection switch offset ΔTic ^c K	
TL 120	Precooling	> Tem1	–	0 to 15	0	100	+ 22	+ 2	
TL 121	Regulation	> Tem1	–	0 to 15	0	100	+ 22	+ 2	
TL 122	Regulation	> Tem1	–	0 to 15	100	100	+ 22	+ 2	
TL 123	Regulation	> Tem1	–	0 to 15	100	100	+ 18	- 2	Extreme position
TL 124	Regulation	> Tem1	–	0 to 15	100	100	+ 26	+ 4	Extreme position
TL 125	Regulation	> Tem1	–	0 to 15	0	0	+ 22	+ 2	Tests with different fan speeds if manual fan control is available ^d
TL 126	Cooling performance	> Tem1	–	0 to 15	100	100	–	–	Manual control (temperature control override) ^d
TL 127	Extreme condition	Tem2	–	0 to 15	0	0	–	–	Equipment function check ^e

^a Tem1 = + 25 °C for zone II and III and Tem1 = + 30 °C for zone I; Tem2 = + 45 °C for zone I, Tem2 = + 40 °C for zone II and Tem2 = + 33 °C for zone III.
^b See EN 14813-1:2006, 8.2.2.
^c See EN 14813-1:2006, 8.2.3.
^d Optional.
^e These tests may be carried out on the air conditioning equipment only.

Annex B (normative)

Test programme for TL2

Table BB.1 — Tests in heating mode — Category A for TL2

Test	Description of test	Mean exterior temperature (Tem) ^a	Relative humidity	Air speed	Simulation of occupation of the driving cab	Equivalent solar load	Interior temperature setting (Tic)		Remarks
							Constant temperature control ^b	Selection switch offset ΔT_{ic} ^c	
		°C	%	km/h	%	%	°C	K	
TL 2100	Preheating	Tem1	–	0 to 15	0	0	+ 22	+ 2	
TL 2101	Regulation	Tem1	–	0 to 15	0	0	+ 22	+ 2	
TL 2102	Regulation	Tem1	–	0 to 15	0	0	+ 18	- 2	Extreme position
TL 2103	Regulation	Tem1	–	0 to 15	0	0	+ 26	+ 4	Extreme position
TL 2104	Regulation	Tem1	–	0 to 15	0	0	+ 22	+ 2	Tests with different fan speeds if manual fan control is available ^d
TL 2105	Regulation	Tem1	–	Maximum operational speed	0	0	+ 22	+ 2	
TL 2106	Heating performance	Tem1	–	Maximum operational speed	0	0	–	–	Manual control (temperature control override) ^d
TL 2107	Extreme condition	Tem2	–	0 to 15	0	0	–	–	Equipment function check
TL 2108	Preheating	0	–	0 to 15	0	0	+ 22	+ 2	

Table B.1 (concluded)

Test	Description of test	Mean exterior temperature (Tem) ^a	Relative humidity	Air speed	Simulation of occupation of the driving cab	Equivalent solar load	Interior temperature setting (Tic)		Remarks
							Constant temperature control ^b	Selection switch offset ΔT_{ic} ^c	
		°C	%	km/h	%	%	°C	K	
TL 2109	Regulation	0	–	0 to 15	0	0	+ 22	+ 2	
TL 2110	Regulation	0	–	Maximum operational speed	0	0	+ 22	+ 2	
TL 2111	Regulation	0	–	0 to 15	100	0	+ 22	+ 2	
TL 2112	Static <i>k</i> value	5 ± 2	–	0 to 15	0	0	–	–	

^a Tem1 = - 10 °C for zone I, Tem1 = - 20 °C for zone II and Tem1 = - 40 °C for zone III; Tem2 = Tem1 - 5 K.

^b See EN 14813-1:2006, 8.2.2.

^c See EN 14813-1:2006, 8.2.3.

^d Optional.

Table BB.2 — Tests in cooling mode — Category A for TL2

Test	Description of test	Mean exterior temperature (Tem) ^a	Relative humidity ^a	Air speed	Simulation of occupation of the driving cab	Equivalent solar load	Interior temperature setting (Tic)		Remarks
							Constant temperature control ^b	Selection switch offset Δ Tic ^c	
		°C	%	km/h	%	%	°C	K	
TL 2200	Precooling	Tem1	RH1	0 to 15	0	100	+ 18	- 2	Interior temperature setting (Tic) to the minimum to avoid early regulation
TL 2201	Regulation	Tem1	RH1	0 to 15	0	100	^d	+ 2	
TL 2202	Regulation	Tem1	RH1	0 to 15	100	100	^d	+ 2	
TL 2203	Regulation	Tem1	RH1	Maximum operational speed	100	100	^d	+ 2	
TL 2204	Extreme condition	Tem3	RH1	0 to 15	0	0	–	–	Equipment function check
TL 2205	Regulation	Tem2	RH2	0 to 15	0	0	+ 22	+ 2	
TL 2206	Regulation	Tem2	RH2	0 to 15	0	100	+ 22	+ 2	
TL 2207	Regulation	Tem2	RH2	0 to 15	100	100	+ 22	+ 2	
TL 2208	Regulation	Tem2	RH2	0 to 15	100	100	+ 18	- 2	Extreme position
TL 2209	Regulation	Tem2	RH2	0 to 15	100	100	+ 26	+ 4	Extreme position

Table B.2 (concluded)

Test	Description of test	Mean exterior temperature (Tem) ^a	Relative humidity ^a	Air speed	Simulation of occupation of the driving cab	Equivalent solar load	Interior temperature setting (Tic)		Remarks
							Constant temperature control ^b	Selection switch offset ΔT_{ic} ^c	
		°C	%	km/h	%	%	°C	K	
TL 2210	Regulation	Tem2	RH2	0 to 15	100	100	+ 22	+ 2	Tests with different fan speeds if manual fan control is available ^d

^a

	Tem 1	RH1	Tem 2	RH2
Zone I	+ 40 °C	40 %	+ 28 °C	60 %
Zone II	+ 35 °C	50 %	+ 28 °C	60 %
Zone III	+ 28 °C	45 %	+ 22 °C	45 %

Tem 3=Tem 1 + 5 K (+10 K).

^b See EN 14813-1:2006, 8.2.2.

^c See EN 14813-1:2006, 8.2.3.

^d Optional.

Table BB.3 — Tests in heating mode — Category B for TL2

Test	Description of test	Mean exterior temperature (Tem) ^a	Relative humidity	Air speed	Simulation of occupation of the driving cab	Equivalent solar load	Interior temperature setting (Tic)		Remarks
							Constant temperature control ^b	Selection switch offset ΔT_{ic} ^c	
		°C	%	km/h	%	%	°C	K	
TL 2100	Preheating	Tem	–	0 to 15	0	0	+ 22	+ 2	
TL 2101	Regulation	Tem	–	0 to 15	0	0	+ 22	+ 2	
TL 2102	Regulation	Tem	–	0 to 15	0	0	+ 18	- 2	Extreme position
TL 2103	Regulation	Tem	–	0 to 15	0	0	+ 26	+ 4	Extreme position
TL 2104	Regulation	Tem	–	0 to 15	0	0	+ 22	+ 2	Tests with different fan speeds if manual fan control is available ^d
TL 2105	Regulation	Tem	–	Maximum operational speed	0	0	+ 22	+ 2	
TL 2106	Heating performance	Tem	–	Maximum operational speed	0	0	–	–	Manual control (temperature control override) ^d
TL 2107	Static <i>k</i> value	5 ± 2	–	0 to 15	0	0	–	–	

^a Tem = 0 °C for zone I, Tem = - 10 °C for zone II and III.

^b See EN 14813-1:2006, 8.2.2.

^c See EN 14813-1:2006, 8.2.3.

^d Optional.

Table BB.4 — Tests in cooling mode — Category B for TL2

Test	Description of test	Mean exterior temperature (Tem) ^a	Relative humidity ^a	Air speed	Simulation of occupation of the driving cab	Equivalent solar load	Interior temperature setting (Tic)		Remarks
							Constant temperature control ^b	Selection switch offset ΔT_{ic} ^c	
		°C	%	km/h	%	%	°C	K	
TL 2200	Precooling	Tem1	RH1	0 to 15	0	100	+ 18	- 2	Interior temperature setting (Tic) to the minimum to avoid early regulation
TL 2201	Cooling performance	Tem1	RH1	0 to 15	100	100	^d	^d	
TL 2202	Regulation	Tem2	RH2	0 to 15	100	100	+ 22	+ 2	
TL 2203	Regulation	Tem2	RH2	0 to 15	100	100	+ 18	- 2	Extreme position
TL 2204	Regulation	Tem2	RH2	0 to 15	100	100	+ 26	+ 4	Extreme position
TL 2205	Regulation	Tem2	RH2	0 to 15	100	100	+ 22	+ 2	Tests with different fan speeds if manual fan control is available ^d

^a

	Tem 1	RH1	Tem 2	RH2
Zone I	+ 40 °C	40 %	+ 28 °C	60 %
Zone II	+ 35 °C	50 %	+ 28 °C	60 %
Zone III	+ 28 °C	45 %	+ 22 °C	45 %

^b See EN 14813-1:2006, 8.2.2.

^c See EN 14813-1:2006, 8.2.3.

^d Optional.

Annex C (normative)

Equivalent solar load

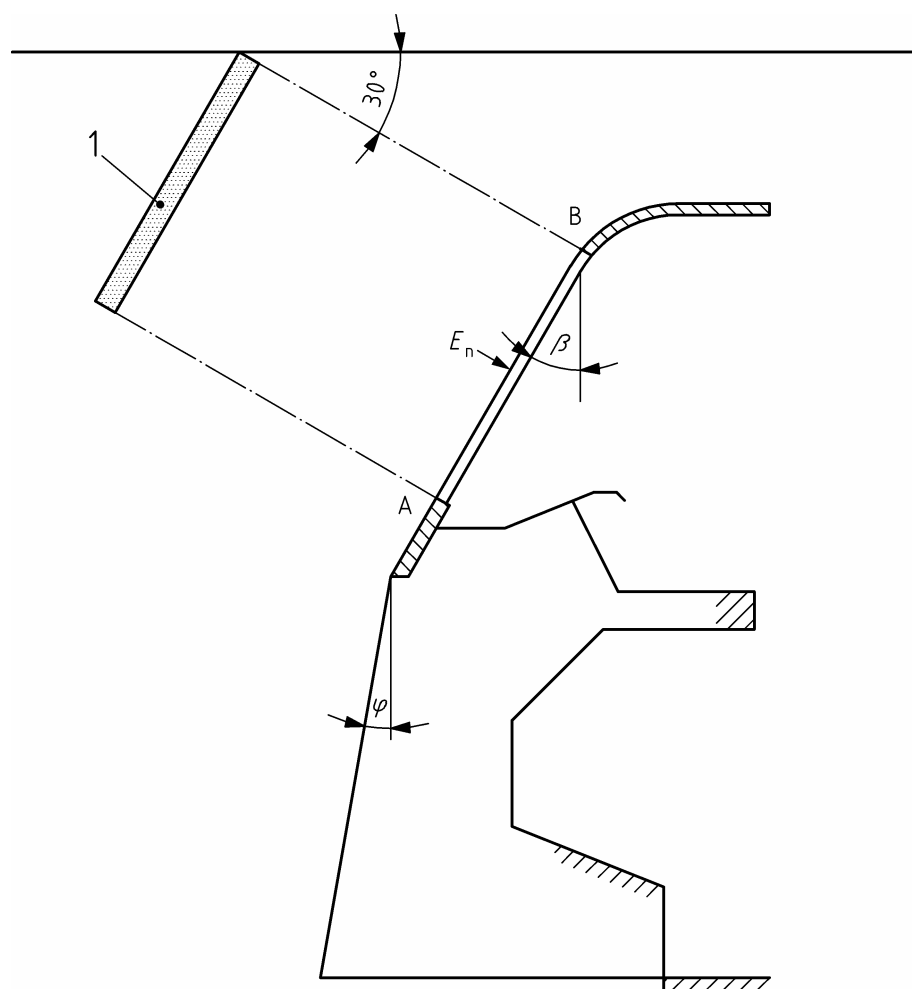

Key

- 1 solar radiation lamps
 E_n equivalent solar energy on a surface perpendicular to the radiation
 E_n is defined in EN 14813-1:2006, Annex D and Annex E
 β inclination of the front window in relation to the vertical plane, in degrees
 φ inclination of the front wall in relation to the vertical plane, in degrees

Figure C.1 — Simulation of solar exposure

- Whatever type of driving cab, the solar load shall be effective at least between points A and B on the front window;
- the bank of solar radiation lamps shall be at minimum, the same width as the driving cab on test.

Annex D
(normative)

Location of the measuring points in a driving cab

Dimensions in millimetres

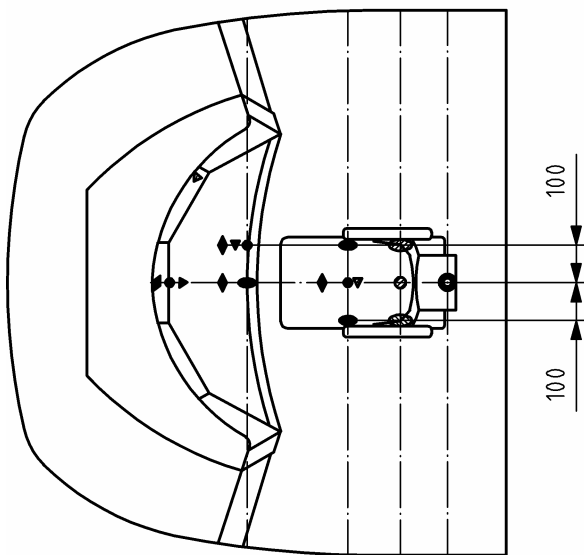
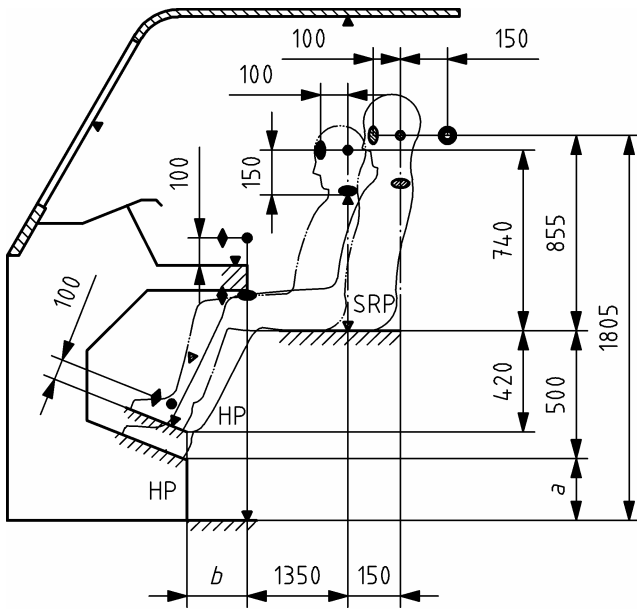

Key

- SRP seat reference point
- HP heel point
- a, b construction dimension
- 1 air temperature
- 2 air temperature
- 3 surface temperature
- 4 air velocity
- 5 relative humidity
- 6 optional measuring points



Figure D.1 — Measuring points for seated driver

Dimensions in millimetres

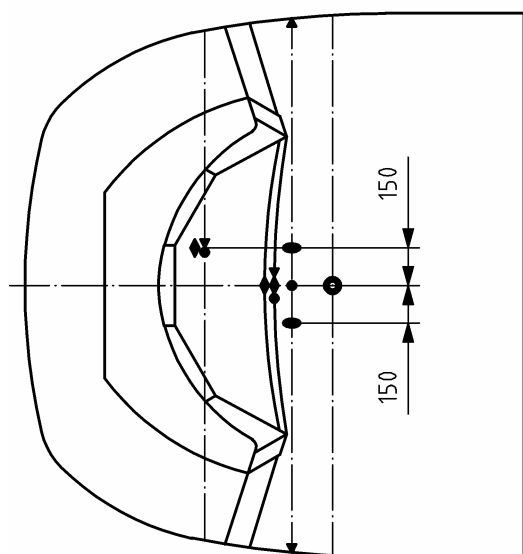
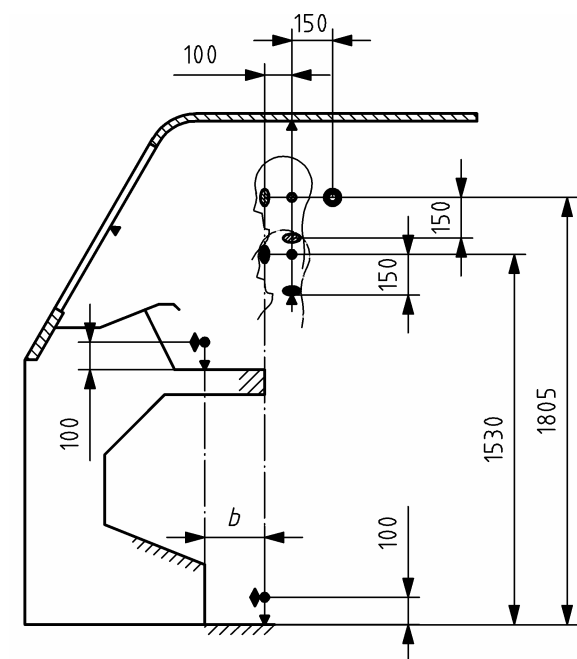

Key

- b construction dimension
- 1 air temperature
- 2 air temperature
- 3 surface temperature
- 4 air velocity
- 5 relative humidity
- 6 optional measuring points

Figure D.2 — Measuring points for standing driver

Annex E
(normative)

Location of the temperature sensors in the test chamber

Dimensions in metres

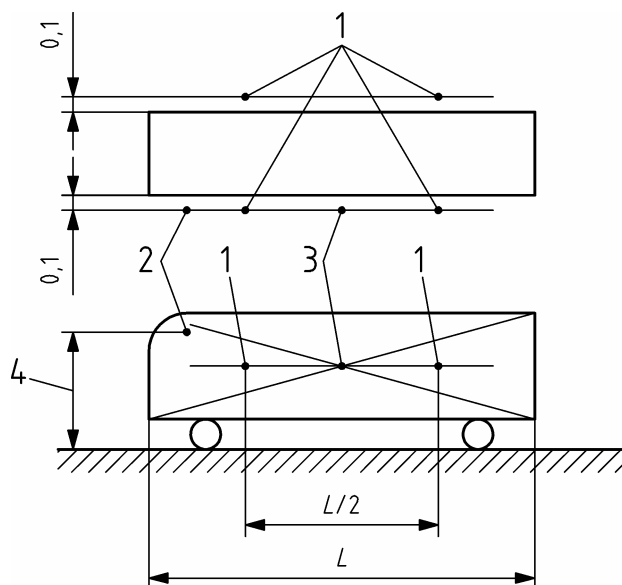

Key

- 1 temperature sensors (four)
- 2 humidity sensor, one humidity sensor positioned 0,1 m from each vehicle fresh air inlet grill
- 3 air speed sensor (for driving cab measurement alone, the air speed should be also measured in front of the cab)
- 4 fresh air grille height

Figure E.1 — Location of sensors

Tem is the arithmetic mean value of the four temperature measurement points.

Annex ZA (informative)

Relationship between this European Standard and the Essential Requirements of EU Directive 96/48/EC

This European Standard has been prepared under a mandate given to CEN by the European Commission and the European Free Trade Association to provide a means of conforming to Essential Requirements of the Directive 96/48/EC, as amended by Directive 2004/50/EC which is based on the principles of the New Approach, on the interoperability of the trans-european high speed rail system.

Once this standard is cited in the Official Journal of the European Communities under that Directive and has been implemented as a national standard in at least one Member State, compliance with the clauses of this standard given in Table ZA.1 confers, within the limits of the scope of this standard, a presumption of conformity with the corresponding Essential Requirements of that Directive and associated EFTA regulations.

Table ZA.1 — Correspondence between this European Standard and Directive 96/48/EC

Clause(s)/sub-clause(s) of this EN	Essential Requirements (ERs) of Directive 96/48/EC	Chapters/points of TSI Rolling Stock	Qualifying remarks/Notes
All clauses	Annex III – Essential requirements 2 Requirements specific to each subsystems 2.4 Rolling stock 2.4.3 Technical compatibility	3.3.5 Technical compatibility: Essential requirement 2.4.3 Section 3: The characteristics of the rolling stock must be such as to allow it to travel on any line on which it is expected to operate. This essential requirement is covered by values of the basic parameters ... 4.1.11. Boundary characteristics linked to air conditioning (BP21) Driving cab: The ventilation of the driving cab shall be such as to ensure that carbon monoxide and dioxide levels remain under the level set by European health and safety legislation.	This draft standard defines the testing methods of the performances of the air conditioning equipment of driving cabs. A specific test to measure the carbon monoxide and dioxide levels in the cab is not necessary because it is known by experience how much carbon dioxide is emitted by a person and that the fresh air input per hour and person specified in EN 14813-1:2006, 9.6.1 is sufficient to remain within the health and safety levels.

WARNING — Other requirements and other EU Directives may be applicable to the product(s) falling within the scope of this standard.

BSI — British Standards Institution

BSI is the independent national body responsible for preparing British Standards. It presents the UK view on standards in Europe and at the international level. It is incorporated by Royal Charter.

Revisions

British Standards are updated by amendment or revision. Users of British Standards should make sure that they possess the latest amendments or editions.

It is the constant aim of BSI to improve the quality of our products and services. We would be grateful if anyone finding an inaccuracy or ambiguity while using this British Standard would inform the Secretary of the technical committee responsible, the identity of which can be found on the inside front cover.
Tel: +44 (0)20 8996 9000. Fax: +44 (0)20 8996 7400.

BSI offers members an individual updating service called PLUS which ensures that subscribers automatically receive the latest editions of standards.

Buying standards

Orders for all BSI, international and foreign standards publications should be addressed to Customer Services. Tel: +44 (0)20 8996 9001.
Fax: +44 (0)20 8996 7001. Email: orders@bsi-global.com. Standards are also available from the BSI website at <http://www.bsi-global.com>.

In response to orders for international standards, it is BSI policy to supply the BSI implementation of those that have been published as British Standards, unless otherwise requested.

Information on standards

BSI provides a wide range of information on national, European and international standards through its Library and its Technical Help to Exporters Service. Various BSI electronic information services are also available which give details on all its products and services. Contact the Information Centre.
Tel: +44 (0)20 8996 7111. Fax: +44 (0)20 8996 7048. Email: info@bsi-global.com.

Subscribing members of BSI are kept up to date with standards developments and receive substantial discounts on the purchase price of standards. For details of these and other benefits contact Membership Administration.
Tel: +44 (0)20 8996 7002. Fax: +44 (0)20 8996 7001.
Email: membership@bsi-global.com.

Information regarding online access to British Standards via British Standards Online can be found at <http://www.bsi-global.com/bsonline>.

Further information about BSI is available on the BSI website at <http://www.bsi-global.com>.

Copyright

Copyright subsists in all BSI publications. BSI also holds the copyright, in the UK, of the publications of the international standardization bodies. Except as permitted under the Copyright, Designs and Patents Act 1988 no extract may be reproduced, stored in a retrieval system or transmitted in any form or by any means – electronic, photocopying, recording or otherwise – without prior written permission from BSI.

This does not preclude the free use, in the course of implementing the standard, of necessary details such as symbols, and size, type or grade designations. If these details are to be used for any other purpose than implementation then the prior written permission of BSI must be obtained.

Details and advice can be obtained from the Copyright & Licensing Manager.
Tel: +44 (0)20 8996 7070. Fax: +44 (0)20 8996 7553.
Email: copyright@bsi-global.com.