

Execution of special geotechnical works — Ground treatment by deep vibration

The European Standard EN 14731:2005 has the status of a
British Standard

ICS 93.020

National foreword

This British Standard is the official English language version of EN 14731:2005.

The UK participation in its preparation was entrusted to Technical Committee B/526, Geotechnics, which has the responsibility to:

- aid enquirers to understand the text;
- present to the responsible international/European committee any enquiries on the interpretation, or proposals for change, and keep UK interests informed;
- monitor related international and European developments and promulgate them in the UK.

A list of organizations represented on this committee can be obtained on request to its secretary.

Cross-references

The British Standards which implement international or European publications referred to in this document may be found in the *BSI Catalogue* under the section entitled “International Standards Correspondence Index”, or by using the “Search” facility of the *BSI Electronic Catalogue* or of British Standards Online.

This publication does not purport to include all the necessary provisions of a contract. Users are responsible for its correct application.

Compliance with a British Standard does not of itself confer immunity from legal obligations.

Summary of pages

This document comprises a front cover, an inside front cover, the EN title page, pages 2 to 24, an inside back cover and a back cover.

The BSI copyright notice displayed in this document indicates when the document was last issued.

Amendments issued since publication

Amd. No.	Date	Comments

This British Standard was published under the authority of the Standards Policy and Strategy Committee on 24 November 2005

© BSI 24 November 2005

ISBN 0 580 47281 7

EUROPEAN STANDARD

EN 14731

NORME EUROPÉENNE

EUROPÄISCHE NORM

September 2005

ICS 93.020

English Version

Execution of special geotechnical works - Ground treatment by deep vibration

Exécution de travaux géotechniques spéciaux -
Amélioration des massifs de sol par vibration

Ausführung von besonderen geotechnischen Arbeiten
(Spezialtiefbau) - Baugrundverbesserung durch
Tiefenrüttelverfahren

This European Standard was approved by CEN on 8 August 2005.

CEN members are bound to comply with the CEN/CENELEC Internal Regulations which stipulate the conditions for giving this European Standard the status of a national standard without any alteration. Up-to-date lists and bibliographical references concerning such national standards may be obtained on application to the Central Secretariat or to any CEN member.

This European Standard exists in three official versions (English, French, German). A version in any other language made by translation under the responsibility of a CEN member into its own language and notified to the Central Secretariat has the same status as the official versions.

CEN members are the national standards bodies of Austria, Belgium, Cyprus, Czech Republic, Denmark, Estonia, Finland, France, Germany, Greece, Hungary, Iceland, Ireland, Italy, Latvia, Lithuania, Luxembourg, Malta, Netherlands, Norway, Poland, Portugal, Slovakia, Slovenia, Spain, Sweden, Switzerland and United Kingdom.



EUROPEAN COMMITTEE FOR STANDARDIZATION
COMITÉ EUROPÉEN DE NORMALISATION
EUROPÄISCHES KOMITEE FÜR NORMUNG

Management Centre: rue de Stassart, 36 B-1050 Brussels

Contents

page

Foreword	4
1 Scope	5
2 Normative references	5
3 Terms and definitions	6
4 Information needed for the execution of the work	7
4.1 General	7
4.2 Special features for ground treatment by deep vibration	7
5 Geotechnical investigation.....	8
5.1 General	8
5.2 Specific aspects for deep vibratory compaction.....	8
5.3 Specific aspects for vibrated stone columns	9
6 Materials and products.....	9
6.1 General	9
6.2 Materials for deep vibratory compaction	9
6.3 Materials for vibrated stone columns.....	9
7 Considerations related to design.....	10
7.1 General	10
7.2 Selection of treatment method.....	10
7.3 Design verification	11
7.4 Extent and layout of treatment.....	11
7.5 Sequence of treatment	11
8 Execution.....	12
8.1 General	12
8.2 Site preparation.....	12
8.3 Setting out	12
8.4 Treatment.....	12
9 Supervision, testing and monitoring	13
9.1 Supervision and monitoring.....	13
9.2 Testing	14
10 Records	15
10.1 Records in connection with the execution of the ground treatment.....	15
10.2 Records at completion of the ground treatment	16
11 Special requirements.....	16
11.1 General	16

11.2	Safety	16
11.3	Environmental protection.....	16
11.4	Impact on adjacent structures	17
	Annex A (informative) Deep vibratory compaction.....	18
	Annex B (informative) Installation of vibrated stone columns.....	20
B.1	General	20
B.2	Dry top-feed process	20
B.3	Wet process.....	21
B.4	Dry bottom-feed process.....	22
	Bibliography.....	24

EN 14731:2005 (E)

Foreword

This European Standard (EN 14731:2005) has been prepared by Technical Committee CEN/TC 288 “Execution of special geotechnical works”, the secretariat of which is held by AFNOR.

This European Standard shall be given the status of a national standard, either by publication of an identical text or by endorsement, at the latest by March 2006, and conflicting national standards shall be withdrawn at the latest by March 2006.

According to the CEN/CENELEC Internal Regulations, the national standards organizations of the following countries are bound to implement this European Standard: Austria, Belgium, Cyprus, Czech Republic, Denmark, Estonia, Finland, France, Germany, Greece, Hungary, Iceland, Ireland, Italy, Latvia, Lithuania, Luxembourg, Malta, Netherlands, Norway, Poland, Portugal, Slovakia, Slovenia, Spain, Sweden, Switzerland and United Kingdom.

1 Scope

This European Standard is applicable to the planning, execution, testing and monitoring of ground treatment by deep vibration achieved by depth vibrators and compaction probes.

The following types of treatment are covered by this European Standard:

- deep vibratory compaction to densify the existing ground;
- vibrated stone columns to form a stiffened composite ground structure by the insertion of granular material which itself shall be densified. Generally, stone columns have a diameter greater than 0,6 m and lower than 1,2 m.

The following treatment methods are covered by this European Standard:

- methods in which depth vibrators, containing oscillating weights which cause horizontal vibrations, are inserted into the ground;
- methods in which compaction probes are inserted into the ground using a vibrator which remains at the ground surface and which in most cases oscillates in a vertical mode.

Treatment methods are outlined in Annexes A and B.

The following treatment methods, among others, are not included in this European Standard:

- methods in which sand or stone columns are installed by means of impact or top vibratory driven casing;
- methods in which very stiff columns are formed either by the addition of cement to granular material or by the use of concrete or any other binder;
- dynamic compaction and other methods in which some form of treatment is applied to the ground surface;
- explosive compaction.

2 Normative references

The following referenced documents are indispensable for the application of this European Standard. For dated references, only the edition cited applies. For undated references, the latest edition of the referenced document (including any amendments) applies.

EN 791, *Drill rigs – Safety*

EN 996, *Piling equipment – Safety requirements*

EN 1990, *Eurocode: Basis of structural design*

EN 1997-1:2004, *Eurocode 7: Geotechnical design – Part 1: General rules*

prEN 1997-2, *Eurocode 7: Geotechnical design – Part 2: Ground investigation and testing*

3 Terms and definitions

For the purposes of this European Standard, the following terms and definitions apply.

Additional descriptions of some of the ground treatment methods are given in Annexes A and B.

3.1

deep vibratory compaction

type of ground treatment by deep vibration in which the main purpose is to densify the soil. The treatment is applicable to many granular soils and normally results in increased strength and stiffness, reduced permeability and reduced susceptibility to liquefaction

3.2

vibrated stone columns¹⁾

type of ground treatment by deep vibration in which a depth vibrator is used to form continuous stone columns from the maximum depth of penetration up to the ground surface, and hence to form a stone column/soil structure which should have an increased strength and stiffness compared with the ground in an untreated state. The treatment is applicable to a wide range of soils and in granular soils some densification may also be achieved. Three installation processes, the dry top-feed process, the wet process and the dry bottom-feed process are described in Annex B

3.3

vibrating tool

item of equipment which is inserted into the ground to cause vibration at depth; commonly a depth vibrator containing oscillating weights or a compaction probe inserted into the ground using a top vibrator which remains at the ground surface

3.4

depth vibrator

basic component of ground treatment equipment used in the installation of vibrated stone columns and in vibro compaction, which vibrates horizontally by means of an eccentric weight rotating about its longitudinal axis, and penetrates into the ground. The penetration in the ground can be made easier by air or water flushing

3.5

top vibrator

vibrator which remains above the ground surface

3.6

compaction probe

tool for deep vibratory compaction which is inserted into the ground to transmit vibrations from a top vibrator which remains at the ground surface; wings, drainage or water flushing can be provided to facilitate the compaction process

3.7

deep vibro compaction

technique in which a depth vibrator is used to compact granular soil with or without the formation of stone columns

3.8

dry top-feed process

method of installing vibrated stone columns in which the hole formed by the depth vibrator remains open and specified granular material is fed directly into the top of the hole and compacted by the vibrator in stages (the process is described in Annex B)

1) Commonly termed vibro stone columns.

3.9**wet process**

method of installing vibrated stone columns in which flushing water removes soft material, stabilises the hole and allows specified granular material to reach the tip of the depth vibrator where it is compacted (the process is described in Annex B)

3.10**dry bottom-feed process**

method of installing vibrated stone columns in which specified granular material is delivered directly to the tip of the vibrator via a feed pipe attached to the vibrator, with the vibrator remaining in the ground during the construction of the column to maintain the stability of the hole (the process is described in Annex B)

4 Information needed for the execution of the work**4.1 General****4.1.1 Prior to the execution of the work, all necessary information shall be provided****4.1.2 The information should include:**

- a) any legal or statutory restrictions;
- b) location of main grid lines or reference points for setting out;
- c) condition of structures, roads and services adjacent to the work;
- d) suitable quality management system, including supervision, monitoring and testing.

4.1.3 The information regarding the site conditions shall cover, where relevant:

- a) geometry of the site including boundary conditions, topography, access, slopes and headroom restrictions;
- b) existing underground structures, services, known contaminants and archaeological constraints;
- c) environmental restrictions including noise, vibration, displacements, pollution and effects of seasonal variations in weather including frozen surface layers;
- d) future or ongoing activities such as dewatering, tunnelling, deep excavations and raising of site levels.

4.1.4 Other information which will be required is described in Clauses 5, 6, 7 and 8.**4.2 Special features for ground treatment by deep vibration**

The information required in relation to the practical aspects of the execution of ground treatment shall include:

- specific project design objectives which the execution of the ground treatment is intended to fulfil;
- water supply and slurry disposal requirements for the wet process of installing vibrated stone columns.

5 Geotechnical investigation

5.1 General

5.1.1 All site investigation shall be undertaken in accordance with EN 1997-1 and prEN 1997-2, and the design of the project.

5.1.2 The extent and depth of the site investigation shall be sufficient to determine the characteristic ground conditions and topography of the site and to identify and locate all ground formations, layers, other geological features and ground water levels affecting the execution of the works.

5.1.3 All information from site investigations shall be made available in accordance with the requirements of Clause 4.

5.1.4 Some fills may be heterogeneous and examination in trial pits may be required for a representative geotechnical description.

5.1.5 Obstructions, hard layers and cobbles and boulders within the ground which would influence or prevent the insertion of the vibrating tool should be identified.

5.1.6 The presence of ground conditions which will affect the performance of treatment shall be identified including:

- hard layers;
- soils sensitive to disturbance;
- soils with potential for collapse settlement on wetting;
- soils with liquefaction potential;
- fills currently settling under self-weight.

5.1.7 Any contaminants and pollutants in the soil or the groundwater should be identified.

5.2 Specific aspects for deep vibratory compaction

5.2.1 Special consideration shall be given to the extent of the treatable granular soils and the location and extent of any layers which restrict or reduce the efficiency of the treatment process including clay, silt and organic layers and layers preventing drainage.

5.2.2 Where clay, silt or organic soils are present, some or all the properties mentioned in 5.3 may be needed.

5.2.3 The following geotechnical properties of the granular soil may be relevant to the design and execution of ground treatment by deep vibratory compaction:

- particle size distribution and fines content;
- *in situ* density index (relative density);
- permeability;
- crushability of particles;
- inter-particle bonding caused by cementation, suction or cohesion.

5.3 Specific aspects for vibrated stone columns

5.3.1 Particular attention should be given to the determination of physical and geotechnical properties required for the design and execution of the ground treatment by vibrated stone columns, for example:

- compressibility;
- consistency limits;
- undrained shear strength;
- sensitivity.

5.3.2 Certain ground conditions need particular consideration, including:

- location and extent of peat and organic soil;
- presence of biodegradable fill including domestic waste.

6 Materials and products

6.1 General

Imported materials may be naturally occurring sands and gravels, crushed rock or recycled materials such as crushed brick or concrete. Quality control testing is described in 9.2.4.

6.2 Materials for deep vibratory compaction

6.2.1 Material may be added during deep vibratory compaction. This may be the natural granular material being compacted at the site or imported material.

6.2.2 Added materials shall be sufficiently hard and chemically inert so as to remain stable during the treatment process and subsequent working life in the anticipated soil and groundwater conditions.

6.3 Materials for vibrated stone columns

Material used to form stone columns shall be:

- sufficiently hard and chemically inert so as to remain stable during column construction and subsequent working life in the anticipated soil and groundwater conditions;
- graded appropriately for compaction to form a dense column fully interlocked with the surrounding ground and in compliance with other requirements such as drainage;
- compatible with the plant used and flow freely within bottom-feed and through-feed delivery systems without arching which may block these systems.

Gradings typically used with the different processes are given in the following table.

Process	Grading in mm
Dry top-feed process	40 to 75
Wet process	25 to 75
Dry bottom-feed process	8 to 50

7 Considerations related to design

7.1 General

7.1.1 The design of ground treatment by deep vibration shall be in accordance with EN 1990, EN 1997-1 and prEN 1997-2.

7.1.2 The information on ground conditions shall be assessed to determine the suitability of the ground for treatment by deep vibration.

7.1.3 The following shall be defined in the design of the ground treatment:

- technical objective of the treatment (e.g. increased bearing capacity, reduced settlement; reduced liquefaction potential, reduced potential for collapse settlement on wetting or reduced permeability);
- required geotechnical properties of the treated ground (e.g. shear strength, stiffness, or permeability);
- criteria on which treatment depth, spacing and extent are decided;
- target performance and the way in which treatment is to be assessed in terms of measurable parameters;
- where excavation subsequent to treatment takes place, proposals for recompaction if necessary.

7.1.4 Due to the nature of ground, variations are to be expected even after treatment and this should be taken into consideration.

7.1.5 Heave or settlement occurring during treatment should be anticipated and allowed for in the design. Where infill is not added during deep vibratory compaction, significant surface settlement is likely and shall be estimated.

7.1.6 Proposed changes in ground level subsequent to treatment shall be assessed and the effect this may have on the treatment shall be evaluated.

7.1.7 Some deep vibration processes require large quantities of water. The effects, if any, of pumping water into the ground on the treatment volume and the surrounding ground shall be allowed for in the design.

7.1.8 The possibility of adverse effects on existing adjacent foundation systems, buildings and services, earthworks, slopes, retaining structures and buried structures, arising from ground movements, pore pressures or vibrations induced by the ground treatment shall be considered in the design.

7.1.9 In cases where adverse effects on adjacent buildings and infrastructure are of concern, a pre-condition survey should be carried out as described in 11.4.

7.1.10 Where stone columns are required to perform as drains, adequate provision should be made for surface drainage. If the existing surface soil is not adequate a surface drainage blanket should be provided. Attention should be given to the drainage properties of the working platform.

7.1.11 Where deep vibratory compaction is not intended to compact the surface layer, rollers or tampers should be used to compact this layer. Alternatively, compaction can be executed from a level above final foundation level.

7.2 Selection of treatment method

7.2.1 The selected method for executing the ground treatment shall be capable of fulfilling the design requirements. Descriptions of the treatment processes are given in Annexes A and B.

7.2.2 Where previous experience of the treatment method on the type of soils prevailing at the site is limited, preliminary trials are advisable to demonstrate the feasibility of the treatment method or to optimise the design of the treatment.

7.2.3 The dry top-feed process shall only be used where the hole formed by the depth vibrator remains open. In other conditions either a dry bottom-feed process or a wet process shall be used.

7.3 Design verification

7.3.1 It is recommended that it is verified that the objectives of the treatment have been achieved.

7.3.2 Suitable means of verifying that the required treatment objectives have been achieved should be identified prior to commencement of ground treatment, in terms of the results of defined tests.

7.3.3 Appropriate methods of testing are described in 9.2.

7.3.4 The type and frequency of testing which is compatible with the requirements for quality control and performance of the treatment shall be specified. The execution and interpretation of geotechnical laboratory and field tests shall comply with the requirements of prEN 1997-2.

7.3.5 Testing, although necessary, may not be sufficient to verify the adequacy of the treatment; appropriate supervision, monitoring and records are required. An observational approach is often appropriate and design is not normally complete until site experience is gained.

7.4 Extent and layout of treatment

7.4.1 The design layout shall include the extent and location of treatment points, and the upper and lower levels of the treatment.

7.4.2 Each treatment point shall be identified by a reference number and its plan location shall be related to fixed reference points or lines.

7.4.3 Natural and artificial obstructions are commonly found and this possibility shall be considered in the design.

7.4.4 A horizontal deviation of up to 150 mm from the plan location can normally be accepted.

7.4.5 The treatment may need to extend beyond the area of the foundation of a structure to be built on the treated ground. This is the case where, for example, a primary objective of treatment is to reduce the vulnerability to liquefaction in an earthquake.

7.4.6 For foundation support, the depth of treatment shall be determined as follows:

- in full-depth treatment the depth vibrator or compaction probe shall penetrate to a competent stratum identified from the site investigation;
- in partial-depth treatment the depth of the treatment shall be adequate to improve the depth of ground loaded by the particular foundation system in order to fulfil the requirements for bearing capacity and total and differential settlement criteria. The potential for movement occurring below the depth of treatment shall be assessed.

7.5 Sequence of treatment

The sequence in which treatment should be executed at individual treatment points and the general direction of progress across large areas should be considered at design stage with regard to the effectiveness of the treatment and the presence of adjacent, buried or overhead structures and services.

8 Execution

8.1 General

Work shall be carried out to written procedures. The method of treatment and equipment employed shall be suitable to achieve the depth of treatment and the design objectives in the prevailing ground conditions. Account shall be taken of concurrent site activities and all equipment movement necessary to properly carry out the ground treatment. Suitably trained and experienced personnel shall be in charge of the execution works.

8.2 Site preparation

8.2.1 The site shall be prepared in such a way that operations can be carried out safely and efficiently. Prior to commencement of ground treatment, services in the ground and overhead shall be identified and clearly marked on site or relocated.

8.2.2 Any near-surface natural or artificial obstructions shall be identified prior to the commencement of ground treatment and broken out with the resulting voids filled with specified granular material, or the layout of the treatment shall be altered to accommodate the obstructions.

8.2.3 Working platforms shall be designed, prepared and maintained in a manner suitable for the safe movement and working of the ground treatment equipment. Material used to provide working platforms shall be suitable for the ground conditions on which it is placed and shall not prevent penetration of the vibrating tool.

8.2.4 Special considerations will apply when working over water.

8.3 Setting out

All treatment points shall be set out within the specified tolerances. The levels of the working platform relative to the specified upper and lower treatment levels shall be checked.

8.4 Treatment

8.4.1 General

8.4.1.1 Ground treatment shall be carried out by penetrating the ground with a vibrating tool. The appropriate method of installation shall be determined with due regard to ground and groundwater conditions in accordance with 7.2.

8.4.1.2 Pre-boring or pre-excavation may be necessary in certain circumstances.

8.4.1.3 Where unforeseen obstructions are encountered below ground level, it shall be determined whether the obstruction is to be removed, or whether the treatment points shall be relocated or adapted. Where it is decided to remove the obstruction, the void shall be backfilled with granular material suitable for compaction.

8.4.2 Deep vibratory compaction

Deep compaction is achieved by penetrating the ground with a depth vibrator or with a compaction probe. Penetration and removal can be assisted by water or air. The treatment method can be used with or without the addition of granular backfill from the ground surface. Deep vibratory compaction is described in Annex A.

8.4.3 Vibrated stone columns

8.4.3.1 Continuous columns shall be formed from the maximum required depth of penetration up to the upper design level as a minimum. A compacted stone column has to be built up by adding successive discrete charges of specified granular material and compacting each one to a chosen level of power consumption.

8.4.3.2 The most appropriate treatment process should be selected from the three principal methods for installing vibrated stone columns described in Annex B, namely the dry top-feed process, the wet process and the dry bottom-feed process.

8.4.3.3 Where the dry bottom-feed process is used, the depth vibrator shall not be removed from the ground during column construction.

8.4.3.4 Where the wet process is used, the water demand is substantial and the water supply shall be determined. Slurry shall be disposed of in accordance with local regulations. When slurry has been disposed in lagoons, on completion of ground treatment the lagoons shall be backfilled and the site reinstated to a defined standard.

8.4.3.5 With the wet process, the depth vibrator shall be kept in the hole during column formation.

8.4.3.6 Stone columns shall be constructed as near vertical as possible. The depth vibrator shall not deviate from the vertical by more than 1 in 20 during column formation.

9 Supervision, testing and monitoring

9.1 Supervision and monitoring

9.1.1 General

9.1.1.1 A suitable quality control procedure shall be established for supervision and monitoring. The supervision of the ground treatment shall be carried out by suitably qualified and experienced persons and in accordance with Clause 4 of EN 1997-1:2004.

9.1.1.2 A plan for the supervision should be available at the ground treatment site. As a minimum, the following shall be noted:

- written procedures, which include a list of critical control parameters;
- site and ground conditions, and significant departures from the design basis;
- any obstructions in the ground which hinder or prevent penetration of the ground by the vibrating tool.

9.1.1.3 The effect on the design of any changes to specified treatment procedures where unforeseen conditions are encountered or new information about soil conditions becomes available, shall be evaluated and action agreed prior to the change being made.

9.1.1.4 Critical control parameters shall be monitored during the treatment process, and recorded. Continuous recording shall be used. Execution parameters listed in Clause 10 shall be monitored. Where adverse effects on the surrounding ground have been identified, suitable monitoring shall be included in the written procedures.

EN 14731:2005 (E)

9.1.2 Deep vibratory compaction

In addition to the items listed in 9.1.1, the following should be monitored as they provide a means of assessing the treatment and information which can be used in controlling the treatment:

- where fill is imported, the quantity of imported fill, its origin, type and grading;
- where no fill is imported, the settlement of the ground surface.

9.1.3 Vibrated stone columns

9.1.3.1 Significant variations in consumption of granular material used in forming columns of the same length shall be noted and its effects on the design considered.

9.1.3.2 Any changes in supply or specification of the materials shall be noted and its effects on the design considered.

9.2 Testing

9.2.1 General

9.2.1.1 The primary purpose of testing is to assess the performance of the treatment. With stone columns, some additional testing is done for quality control purposes.

9.2.1.2 The choice of test method should be influenced by the objective of ground treatment.

9.2.1.3 In some situations, the time that has elapsed between treatment and testing will have a significant effect on the test result.

9.2.1.4 The test method shall be specified using, wherever possible, international reference test procedures such as those listed in prEN 1997-2. The parameters to be monitored, the test locations, the frequency of testing and criteria for acceptance shall be defined prior to execution. Testing shall be appropriate for the amount of treatment, variability of ground conditions, type of foundation, depth of influence of foundation loading and any other relevant factors.

9.2.1.5 The number and type of tests and their locations and depth shall be recorded. Signed copies of these records and the test results shall be submitted as required by the contract.

9.2.2 Deep vibratory compaction

9.2.2.1 *In situ* tests should be used for performance testing where changes in ground properties can be measured and directly related to criteria set out in the contract documents or to pre-treatment data obtained using the same technique.

9.2.2.2 One or more of the following *in situ* tests may be carried out:

- cone penetration tests (CPT and CPTU) carried out to provide a continuous record of penetration resistance, friction ratio and, for CPTU, induced pore pressure;
- dilatometer tests (DMT) carried out to determine deformation moduli;
- dynamic probing (DP) carried out to provide a record of the penetration resistance;
- pressuremeter tests (PMT) carried out to determine deformation moduli and/or limit pressures;
- standard penetration tests (SPT) carried out to determine the penetration resistance.

The parameters derived from these *in situ* tests can be empirically correlated with the parameters which control mass behaviour, but a comparison of *in situ* tests carried out before and after treatment will not necessarily reflect the actual improvement in the mass of treated ground.

9.2.2.3 When carried out at a suitable scale and over an appropriate period, loading tests can give a direct measurement of the parameters that control mass behaviour as described in 9.2.3.

9.2.2.4 Other types of testing may be appropriate for particular applications and ground conditions, including geophysical testing, such as seismic wave velocity measurements, sampling and laboratory testing, and borehole permeability testing.

9.2.3 Vibrated stone columns

9.2.3.1 Where vibrated stone columns are installed in granular soils, the tests listed in 9.2.2 may be applicable. The parameters to be monitored, the test locations, the frequency of testing and criteria for acceptance shall be defined prior to execution.

9.2.3.2 Large scale load tests include large plate load tests and zone tests:

- large plate load tests for performance testing should be carried out by loading a rigid plate or cast *in situ* concrete pad large enough to span one or more columns and the intervening ground;
- zone tests should be carried out by loading a large area of treated ground, usually by constructing and loading a full size foundation or placing earth fill to simulate widespread loads.

Location, parameters to be measured, loading procedure, load increments, duration of the test, and load/reload cycles should be specified prior to testing.

9.2.3.3 Individual column plate load tests should be carried out using a plate placed concentrically on individual columns, loaded in increments with the settlement of the plate measured against a stable reference beam.

9.2.4 Materials

9.2.4.1 The hardness of the granular material used to form stone columns should be checked. Where required, tests should be carried out in accordance with procedures for tests of mechanical and physical properties of aggregates given in EN 1097.

9.2.4.2 Where required, the particle size distribution of the granular material should be determined in accordance with prEN 1997-2.

10 Records

10.1 Records in connection with the execution of the ground treatment

Daily records of the treatment process shall be kept and shall be available at the ground treatment site. The records shall show:

- reference number and location of treatment point;
- date and time of work at each treatment point;
- weather conditions;
- method of treatment, reference type of equipment and personnel;

EN 14731:2005 (E)

- depth of penetration at each location;
- time required to reach maximum depth and details of times and depths during withdrawal;
- vibrator power consumption during penetration and compaction of granular material or soil for depth vibrators;
- obstructions and delays;
- any unforeseen conditions encountered;
- presence of heave or settlement of ground surface;
- where stone columns are installed, the quantity used in each column;
- with wet or bottom-feed processes, any occasions when the depth vibrator has had to be removed from the ground during column construction.

10.2 Records at completion of the ground treatment

In the final site records, the following shall be included:

- the as-executed position and depth of each treatment point noting any deviation outside specified tolerances;
- particular directives associated with design and execution which are relevant to subsequent use of the treated ground;
- where stone columns are installed, the source, type and quality of granular material.

11 Special requirements

11.1 General

Only those aspects of site safety and protection of the environment which are specific to ground treatment by deep vibration are considered. All relevant European and national standards, specifications and statutory requirements regarding safety and the environment shall be observed.

11.2 Safety

11.2.1 The ground treatment shall be carried out in a safe manner, including conformance with EN 791 on drilling rig safety and/or with EN 996 on piling equipment safety.

11.2.2 The treatment process involves personnel operating alongside heavy equipment with items suspended from the jib of a crane; safe working practices shall be observed.

11.2.3 Where the treatment process involves a risk of liquefaction, special attention shall be given to the stability of base machines and the overall stability of the site, particularly when working in close proximity to slopes or excavations.

11.3 Environmental protection

Nuisance and/or environmental damage can be caused by noise, dust, vibration and the disposal of effluent. Where required, measures shall be taken in order to limit or avoid such adverse effects. Where water is injected into the ground during treatment, all requirements of the statutory authorities shall be clearly defined.

11.4 Impact on adjacent structures

11.4.1 Where buildings, structures and services are located within or close to the boundary of a proposed area of ground treatment, consideration shall be given to the effects of the treatment upon them arising from vibration and ground movement.

11.4.2 The condition of adjacent structures and installations should be observed and documented prior to the execution of ground treatment and monitored during ground treatment. In appropriate cases, expert advice should be sought prior to commencement of the treatment.

11.4.3 Where required, vibration monitoring shall be carried out during the treatment process with prior agreement of threshold levels.

Annex A (informative)

Deep vibratory compaction

Deep vibratory compaction is usually restricted to granular soils; increasing fines content will reduce the compaction efficiency. It is often found that a fines content of more than 10 % causes difficulties. Soils exhibiting inter-particle bonding due to cementation, suction or some other cause may not be suitable for this type of ground treatment. In some cases, compaction efficiency can be increased by using water flushing, or in combination with vertical drains. Compaction up to ground surface is only possible applying additional measures.

Deep vibratory compaction of granular soils can be achieved by methods which use either a depth vibrator (as shown in Figure A.1) or a top vibrator. Methods using a depth vibrator are similar in principle to the methods described in Annex B, although a stone column is not always to be formed.

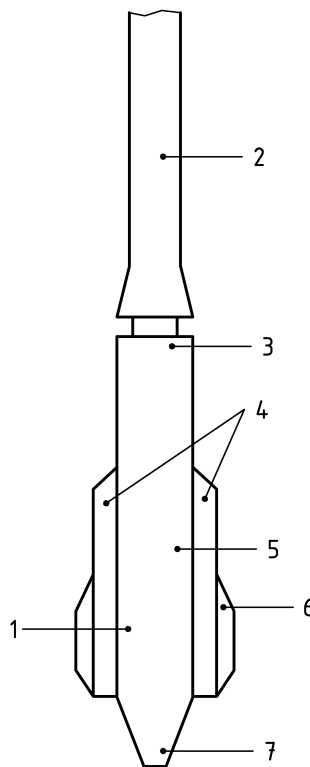

Key

- 1 Eccentric weight (within)
- 2 Extension tube
- 3 Isolator
- 4 Water or air jets
- 5 Motor (within)
- 6 Fins to prevent twist
- 7 Nose cone

Figure A.1 – Depth vibrator

Where a top vibrator is used, it is connected to the top of a compaction probe, which is designed to transfer the vibrations to the soil as efficiently as possible. Several different types of compaction probes are available including the vibro-wing (Figure A.2) and other flexible probes. Conventional vibrators for sheet-pile driving can be used, but special vibrators have been developed. Although the top vibrator usually vibrates vertically, the probe will cause horizontal accelerations which may locally be greater than the vertical ones. The compaction increases when resonance is created between the vibrating system (vibrator and compaction probe) and surrounding soil. By means of vibration sensors placed on the ground, and a vibrator with adjustable frequency, the frequency can be adapted to amplify ground vibrations; this method is known as resonance compaction.

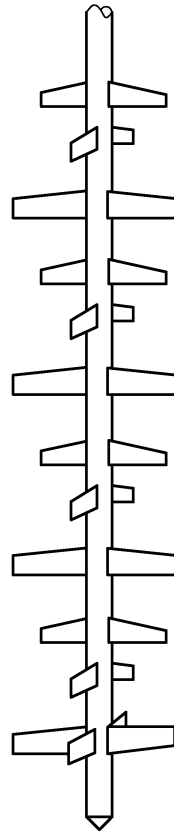

Figure A.2 – Vibro-wing

Compaction is achieved by inserting the probe at treatment points usually on a triangular or rectangular grid. Spacings are typically from 1m to 4 m depending on the type and size of the compaction probe and vibrator capacity. At each treatment point the probe is inserted into the soil to the depth to which compaction is required. The compaction is obtained during penetration or during penetration and extraction. The compaction time at each point varies typically from 5 min to 40 min and the time required increases with the fine content of the soil. Compaction can be effected using several passes, with closer spacings in the later passes.

Annex B (informative)

Installation of vibrated stone columns

B.1 General

There are three principal methods of installing vibrated stone columns, dry top-feed process, wet process and dry bottom-feed process, and for each method the installation of a single column is described. With the vibrated stone column processes, column installation is repeated for further columns at a predetermined spacing to effect the desired treatment. All three processes use a similar type of depth vibrator, which is an eccentric weight assembly rotating rapidly within a heavy tubular steel casing. The general arrangement of the depth vibrator is shown in Figure A.1. The nose of the vibrator is tapered to aid penetration on the ground, whilst vertical fins prevent the vibrator rotating during penetration.

The following descriptions are given as typical. In practice small differences in detail may be noticed.

B.2 Dry top-feed process

In granular soils, this method is usually only possible above the water table. The whole assembly is suspended from a crawler mounted crane and the vibrator is lowered onto the ground. Penetration of the fill and/or underlying weak soil is effected by a combination of the weight of the vibrator, the high frequency vibration and compressed air. A compressor supplies the depth vibrator with air, which emerges from nozzles in the main steel housing just above the vibrator tip. The general arrangement is shown in Figure B.1. After reaching the required depth, the vibrator is held in the ground for a short time and then withdrawn. A small charge of clean, inert granular material is tipped into the hole and the vibrator is lowered again to compact the granular material and interlock it with the surrounding soils. By adding successive small charges of granular material and compacting each one to chosen levels of power consumption, a dense stone column is built up to ground level. Typically gradings for the granular material are within the range from 40 mm to 75 mm.

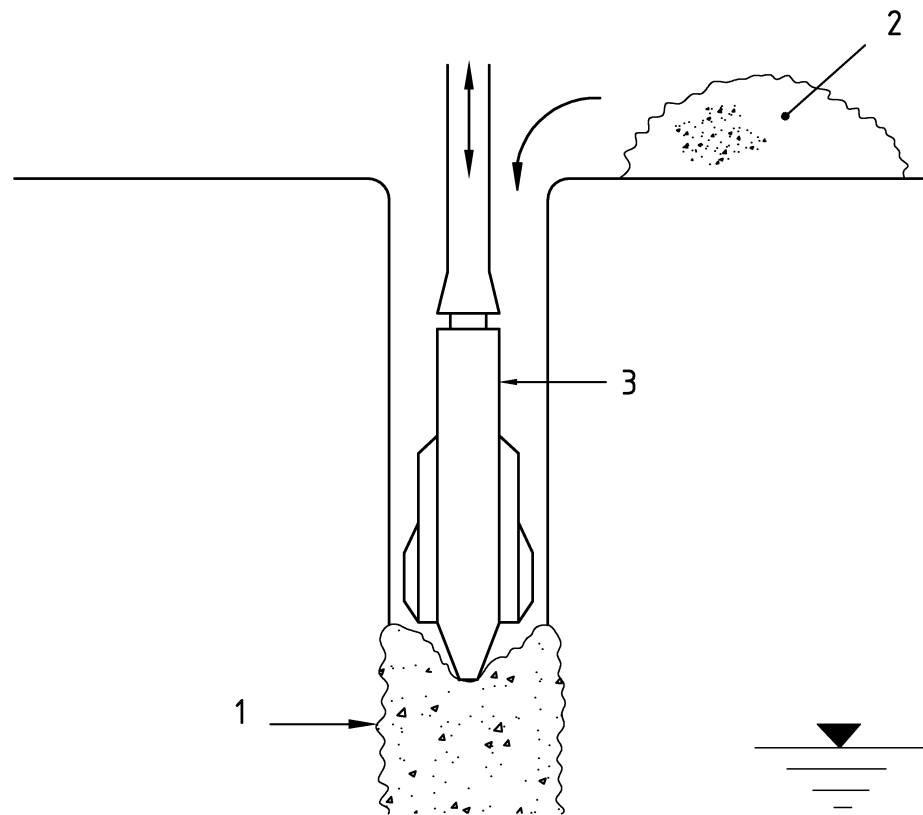
**Key**

- 1 Stone column being formed
- 2 Stockpile of granular infill
- 3 Vibrator

Figure B.1 – Dry top-feed process

B.3 Wet process

The wet process is used where the dry top-feed process cannot be used because of unstable ground. The depth vibrator is similar to that used for the dry process but is equipped with water flushing. The general arrangement is shown in Figure B.2. The depth vibrator is suspended from a suitable crane, lowered onto the ground and the water jets are opened. The vibrator penetrates quickly through weak soils under its own weight aided by the water flushing and vibrations. The vibrator is partially withdrawn and is sometimes surged to flush out the weak soils accumulating in and adjacent to the bore. Following formation of an open hole the vibrator is kept in the ground and the water flow reduced whilst clean inert granular material is successively heaped around the top of the vibrator bore at ground level. The granular material then passes down between the vibrator and the surrounding soils to permit the construction of a stone column in short lifts and repenetration steps. It is important that the water flow is maintained until the vibrator reaches ground surface. The vibrator compacts the granular infill and interlocks it tightly with the surrounding soil. The cycle is repeated until a compact stone column is built up to ground level. Typically gradings for the granular material are within the range from 25 mm to 75 mm.

The wet process has considerable attendant problems of water supply, drainage ditches, settlement lagoons and final disposal of the effluent in a manner acceptable to the statutory authorities.

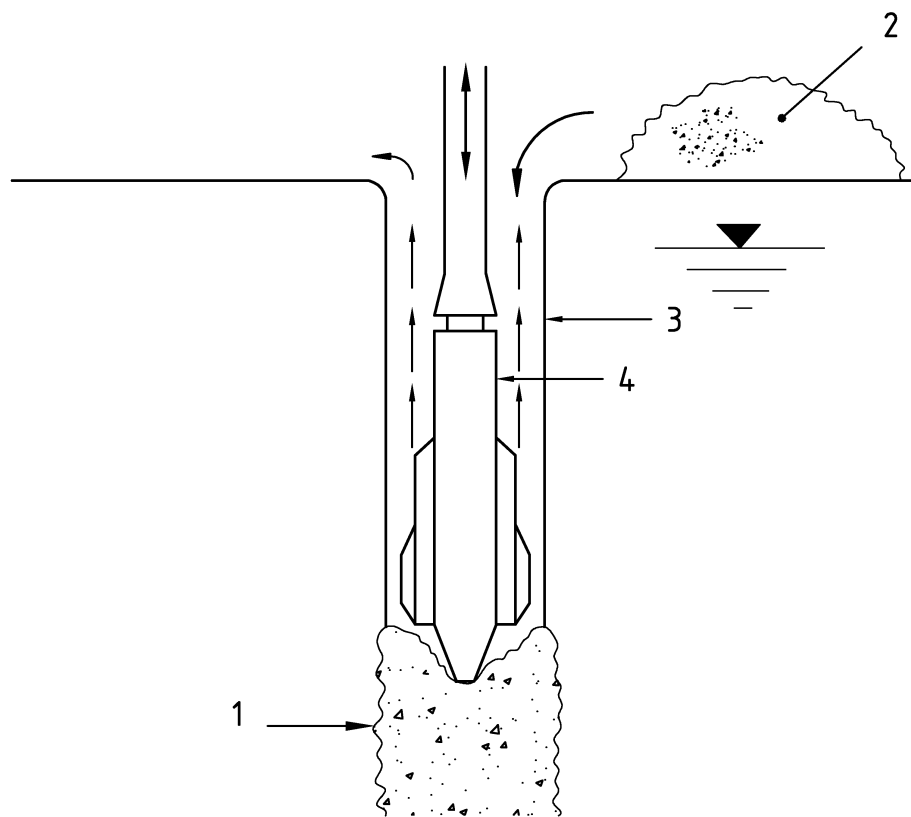

Key

- 1 Stone column
- 2 Stone stockpile
- 3 Water flushing
- 4 Vibrator

Figure B.2 – Wet process

B.4 Dry bottom-feed process

As the vibrator remains in the hole during column construction, the process can operate successfully in unstable hole conditions and can be used instead of the wet process in most cases. The bottom-feed depth vibrator has a heavy duty supply tube located down one side and permanently fixed to the vibrator forming a fully integrated vibrator/granular material supply. The supply tube bends inwards at the vibrator tip to ensure a central location for the supply of granular material. The general arrangement is shown in Figure B.3.

The cycle of operations for this completely dry process is as follows. The vibrator is positioned on the ground at the treatment point location; and the whole system is charged with granular material. With the granular material in the supply tube acting as a plug at the tip of the vibrator, assisted as necessary by compressed air and under the combined action of the vibrations and its weight, using an additional pull down force if necessary, the depth vibrator penetrates the ground to the required depth. The stone column is then formed and compacted by lifting the vibrator, holding the lift for a short time to allow the granular material to run, and then forcing the vibrator down on the charge of granular material to compact and tightly interlock it with the surrounding soil. This is repeated, charging the system with granular material as necessary, until a compact stone column is formed up to ground level. Typically gradings for the granular material are within the range from 8 mm to 50 mm.

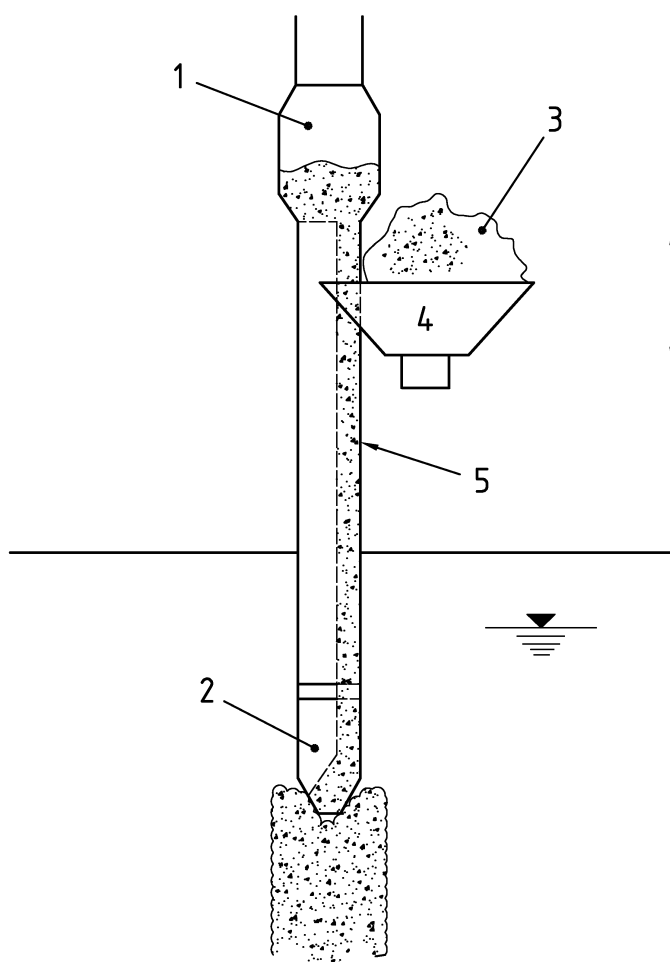

Key

- 1 Pressure chamber
- 2 Vibrator
- 3 Stone stockpile
- 4 Stone feed bucket
- 5 Stone delivery tube

Figure B.3 — Dry bottom-feed process

Bibliography

- [1] EN 1097-1, *Tests for mechanical and physical properties of aggregates – Part 1: Determination of the resistance to wear (micro-Deval)*
- [2] EN 1097-2, *Tests for mechanical and physical properties of aggregates – Part 2: Methods for the determination of the resistance to fragmentation*
- [3] prEN 1998, *Eurocode 8: Design of structures for earthquake resistance*

BSI — British Standards Institution

BSI is the independent national body responsible for preparing British Standards. It presents the UK view on standards in Europe and at the international level. It is incorporated by Royal Charter.

Revisions

British Standards are updated by amendment or revision. Users of British Standards should make sure that they possess the latest amendments or editions.

It is the constant aim of BSI to improve the quality of our products and services. We would be grateful if anyone finding an inaccuracy or ambiguity while using this British Standard would inform the Secretary of the technical committee responsible, the identity of which can be found on the inside front cover.
Tel: +44 (0)20 8996 9000. Fax: +44 (0)20 8996 7400.

BSI offers members an individual updating service called PLUS which ensures that subscribers automatically receive the latest editions of standards.

Buying standards

Orders for all BSI, international and foreign standards publications should be addressed to Customer Services. Tel: +44 (0)20 8996 9001.
Fax: +44 (0)20 8996 7001. Email: orders@bsi-global.com. Standards are also available from the BSI website at <http://www.bsi-global.com>.

In response to orders for international standards, it is BSI policy to supply the BSI implementation of those that have been published as British Standards, unless otherwise requested.

Information on standards

BSI provides a wide range of information on national, European and international standards through its Library and its Technical Help to Exporters Service. Various BSI electronic information services are also available which give details on all its products and services. Contact the Information Centre.
Tel: +44 (0)20 8996 7111. Fax: +44 (0)20 8996 7048. Email: info@bsi-global.com.

Subscribing members of BSI are kept up to date with standards developments and receive substantial discounts on the purchase price of standards. For details of these and other benefits contact Membership Administration.
Tel: +44 (0)20 8996 7002. Fax: +44 (0)20 8996 7001.
Email: membership@bsi-global.com.

Information regarding online access to British Standards via British Standards Online can be found at <http://www.bsi-global.com/bsonline>.

Further information about BSI is available on the BSI website at <http://www.bsi-global.com>.

Copyright

Copyright subsists in all BSI publications. BSI also holds the copyright, in the UK, of the publications of the international standardization bodies. Except as permitted under the Copyright, Designs and Patents Act 1988 no extract may be reproduced, stored in a retrieval system or transmitted in any form or by any means – electronic, photocopying, recording or otherwise – without prior written permission from BSI.

This does not preclude the free use, in the course of implementing the standard, of necessary details such as symbols, and size, type or grade designations. If these details are to be used for any other purpose than implementation then the prior written permission of BSI must be obtained.

Details and advice can be obtained from the Copyright & Licensing Manager.
Tel: +44 (0)20 8996 7070. Fax: +44 (0)20 8996 7553.
Email: copyright@bsi-global.com.