

# Laboratory furniture — Storage units for laboratories — Requirements and test methods

The European Standard EN 14727:2005 has the status of a  
British Standard

ICS 71.040.10

## National foreword

This British Standard is the official English language version of EN 14727:2005.

The UK participation in its preparation was entrusted to Technical Committee FW/0, Furniture, which has the responsibility to:

- aid enquirers to understand the text;
- present to the responsible international/European committee any enquiries on the interpretation, or proposals for change, and keep UK interests informed;
- monitor related international and European developments and promulgate them in the UK.

A list of organizations represented on this committee can be obtained on request to its secretary.

### Cross-references

The British Standards which implement international or European publications referred to in this document may be found in the *BSI Catalogue* under the section entitled “International Standards Correspondence Index”, or by using the “Search” facility of the *BSI Electronic Catalogue* or of British Standards Online.

This publication does not purport to include all the necessary provisions of a contract. Users are responsible for its correct application.

**Compliance with a British Standard does not of itself confer immunity from legal obligations.**

### Summary of pages

This document comprises a front cover, an inside front cover, the EN title page, pages 2 to 22, an inside back cover and a back cover.

The BSI copyright notice displayed in this document indicates when the document was last issued.

### Amendments issued since publication

Amd. No.	Date	Comments

This British Standard was published under the authority of the Standards Policy and Strategy Committee on 16 January 2006

© BSI 16 January 2006

EUROPEAN STANDARD

**EN 14727**

NORME EUROPÉENNE

EUROPÄISCHE NORM

December 2005

---

ICS 71.040.10

English Version

## Laboratory furniture - Storage units for laboratories - Requirements and test methods

Mobilier de laboratoire - Eléments de stockage pour  
laboratoires - Exigences et méthodes d'essai

Labormöbel - Schränke und Regale für Laboratorien -  
Anforderungen und Prüfverfahren

This European Standard was approved by CEN on 29 August 2005.

CEN members are bound to comply with the CEN/CENELEC Internal Regulations which stipulate the conditions for giving this European Standard the status of a national standard without any alteration. Up-to-date lists and bibliographical references concerning such national standards may be obtained on application to the Central Secretariat or to any CEN member.

This European Standard exists in three official versions (English, French, German). A version in any other language made by translation under the responsibility of a CEN member into its own language and notified to the Central Secretariat has the same status as the official versions.

CEN members are the national standards bodies of Austria, Belgium, Cyprus, Czech Republic, Denmark, Estonia, Finland, France, Germany, Greece, Hungary, Iceland, Ireland, Italy, Latvia, Lithuania, Luxembourg, Malta, Netherlands, Norway, Poland, Portugal, Slovakia, Slovenia, Spain, Sweden, Switzerland and United Kingdom.



EUROPEAN COMMITTEE FOR STANDARDIZATION  
COMITÉ EUROPÉEN DE NORMALISATION  
EUROPÄISCHES KOMITEE FÜR NORMUNG

**Management Centre: rue de Stassart, 36 B-1050 Brussels**

## Contents

Page

Foreword .....	4
<b>1</b> <b>Scope</b> .....	<b>5</b>
<b>2</b> <b>Normative references</b> .....	<b>5</b>
<b>3</b> <b>Terms and definitions</b> .....	<b>5</b>
<b>4</b> <b>General test conditions</b> .....	<b>6</b>
4.1 <b>Preliminary preparation</b> .....	6
4.2 <b>Test equipment</b> .....	6
4.3 <b>Tolerances</b> .....	7
4.4 <b>Sequence of testing</b> .....	7
<b>5</b> <b>Test apparatus</b> .....	<b>7</b>
5.1 <b>Test floor</b> .....	7
5.2 <b>Test wall</b> .....	7
5.3 <b>Stops</b> .....	7
5.4 <b>Loading pad</b> .....	7
5.5 <b>Apparatus for slam open of extension elements</b> .....	7
5.6 <b>Dead loads</b> .....	7
5.7 <b>Glass marbles</b> .....	8
5.8 <b>Impact plate</b> .....	8
<b>6</b> <b>General safety requirements</b> .....	<b>8</b>
<b>7</b> <b>Test procedures and requirements</b> .....	<b>8</b>
7.1 <b>Shelves</b> .....	8
7.1.1 <b>Stable positioning of shelves</b> .....	8
7.1.2 <b>Deflection of shelves</b> .....	9
7.2 <b>Shelf supports</b> .....	9
7.3 <b>Pivoted doors</b> .....	10
7.3.1 <b>General</b> .....	10
7.3.2 <b>Strength of pivoted doors</b> .....	10
7.3.4 <b>Durability test on hinged and pivoted doors</b> .....	10
7.3.5 <b>Safety requirements</b> .....	11
7.3.6 <b>Durability requirement</b> .....	11
7.4 <b>Sliding doors and horizontal roll fronts</b> .....	11
7.4.1 <b>General</b> .....	11
7.4.2 <b>Slam open and shut</b> .....	11
7.4.3 <b>Durability test of sliding doors and horizontal roll fronts</b> .....	12
7.4.4 <b>Safety requirements</b> .....	12
7.4.5 <b>Strength and durability requirements</b> .....	12
7.5 <b>Drawers and extension elements</b> .....	12
7.5.1 <b>General</b> .....	12
7.5.2 <b>Slam open test for drawers equipped with open stops</b> .....	12
7.5.3 <b>Strength of drawers and extension elements</b> .....	13
7.5.4 <b>Durability test of drawers and extension element</b> .....	13
7.5.5 <b>Displacement of drawer bottoms</b> .....	13
7.5.6 <b>Safety requirements</b> .....	14
7.5.7 <b>Strength and durability requirements</b> .....	14
7.6 <b>Flaps</b> .....	14
7.6.1 <b>General</b> .....	14
7.6.2 <b>Strength test</b> .....	14
7.6.3 <b>Durability test</b> .....	15
7.6.4 <b>Safety requirements</b> .....	15
7.6.5 <b>Strength and durability requirements</b> .....	15

7.7	Static load on top surfaces of storage units.....	15
7.7.1	Top Surfaces .....	15
7.7.2	Safety requirements.....	15
7.8	Wall and top mounted units .....	15
7.8.1	General .....	15
7.8.2	Tests on movable parts, shelf supports and top surfaces .....	16
7.8.3	Overload .....	16
7.8.4	Safety requirements.....	16
8	Stability .....	17
8.1	Stability with closed drawers and doors .....	17
8.2	Stability with open drawers, flaps and doors .....	17
9	Additional safety requirements for underbench cabinets on castors .....	17
9.1	Retention of drawers on sudden cessation of movement of unit .....	17
9.2	Stopping device .....	17
9.3	Safety requirements.....	17
10	Installation instructions.....	17
11	Test report .....	18
Annex A	(normative) .....	19
A.1	Slam open test of extension elements .....	19
A.1.2	Apparatus .....	19
A.1.3	Calibration .....	19
Annex B	(informative) <b>Example of loading of wall hanging units (see 7.8.3 Overload)</b> .....	22

## Foreword

This European Standard (EN 14727:2005) has been prepared by Technical Committee CEN/TC 207 "Furniture", the secretariat of which is held by UNI.

This European Standard shall be given the status of a national standard, either by publication of an identical text or by endorsement, at the latest by June 2006, and conflicting national standards shall be withdrawn at the latest by June 2006.

According to the CEN/CENELEC Internal Regulations, the national standards organizations of the following countries are bound to implement this European Standard: Austria, Belgium, Cyprus, Czech Republic, Denmark, Estonia, Finland, France, Germany, Greece, Hungary, Iceland, Ireland, Italy, Latvia, Lithuania, Luxembourg, Malta, Netherlands, Norway, Poland, Portugal, Slovakia, Slovenia, Spain, Sweden, Switzerland and United Kingdom.

## 1 Scope

This European Standard specifies requirements and test methods for storage units (see 3.1) used in laboratories.

This European Standard specifies strength, durability and safety requirements to prevent serious injury through normal functional use, as well as misuse that might reasonably be expected to occur.

Safety, depending on the structure of the building, is not included e.g. the strength of wall hanging cabinets includes only the cabinet and its parts. The wall and the fixing in the wall are not included.

It should be understood that the tests do not ensure that structural failure will not eventually occur as a result of habitual misuse or after an excessively long period of service.

Assessment of ageing, degradation and the heating effect of appliances are not included nor are ergonomic aspects or resistance to fire.

## 2 Normative references

The following referenced documents are indispensable for the application of this European Standard. For dated references, only the edition cited applies. For undated references, the latest edition of the referenced document (including any amendments) applies.

EN 131-2, *Ladders -Requirements, testing, marking*

EN 14072:2003, *Glass in furniture – Test methods*

EN 14749:2005 *Domestic and kitchen storage units and worktops - Safety requirements and test methods*

ISO 7619-2, *Rubber, vulcanized or thermoplastic – Determination of indentation hardness - Part 2: IRHD pocket meter method*

## 3 Terms and definitions

For the purposes of this European Standard, the following terms and definitions apply.

### 3.1

#### **storage unit**

item of furniture consisting of cupboards and/or shelves and/or drawers, intended for the storage of laboratory materials and equipment

### 3.2

#### **free-standing unit**

unit not attached to the structure of the building

### 3.3

#### **built-in unit**

unit attached to the structure of the building, directly or via other units

### 3.4

#### **wall-mounted unit**

unit supported entirely by one or more walls of the building

**3.5**

**top mounted unit**

unit supported by the ceiling

**3.6**

**mobile unit**

unit equipped with glides, wheels or castors

**3.7**

**latching device:**

device which automatically holds a door in the fully open or fully closed position

**3.8**

**locking mechanism**

device which prevents a door from opening once it has been activated by a deliberate movement

## **4 General test conditions**

### **4.1 Preliminary preparation**

The furniture shall be tested as delivered. If of knock-down type, it shall be assembled according to instructions supplied with the furniture. If the furniture can be assembled or combined in different ways, the most adverse combination shall be used for each test. The same is valid for units that can be combined with other units or components.

The test unit shall be stored in indoor ambient conditions for at least one week immediately prior to testing. Any deviation from this procedure shall be stated in the test report.

Except for the deflection of shelves, the tests shall be carried out in indoor ambient conditions, but if during a test the temperature is outside the range 15 °C to 25 °C, the maximum and/or minimum temperature shall be recorded in the test report.

The tests for the deflection of shelves shall be carried out at a relative humidity of 45 % to 55 %, If during a test the relative humidity is outside this range, the maximum and/or minimum shall be recorded in the test report.

Where applicable, units shall be mounted with the fixing points specified by the manufacturer, using fixings which will not fail during the tests.

Tighten any assembly fittings before testing.

The tests refer to furniture parts with conventional function. Combination of tests may be necessary to cover the properties of multi-function components, e.g. a shelf that can be pulled out on runners shall be tested for strength of shelf supports and tested for strength of the runners.

### **4.2 Test equipment**

The forces in the static load tests shall be applied sufficiently slowly to ensure that dynamic loads are negligible. Operation tests shall be carried out sufficiently slowly to ensure that kinetic heating does not occur.

Unless otherwise specified, the test loads may be applied by any suitable device because results are not dependent upon the apparatus, provided the test equipment does not restrict deformation under load or tipping except when specifically required.



### 4.3 Tolerances

Unless otherwise stated the following tolerances are applicable:

forces  $\pm 5\%$  of the nominal force;

velocities  $\pm 5\%$  of the nominal velocity;

masses  $\pm 1,0\%$  of the nominal mass;

dimensions  $\pm 1,0$  mm on the nominal dimension;

Angles  $\pm 2^\circ$  of the nominal angle.

The accuracy for the positioning of loading pads shall be  $\pm 5$  mm.

If masses are used instead of forces, the relationship  $10\text{ N} = 1\text{ kg}$  shall be used.

### 4.4 Sequence of testing

All the tests specified for a component, e.g. doors, shall be carried out in the sequence laid down in this European Standard, but it is not necessary to test the different components of the article e.g. doors or drawers in the sequence of the clauses.

All tests specified for a component part and/or unit shall be carried out on the same sample.

## 5 Test apparatus

### 5.1 Test floor

A rigid, horizontal and flat surface.

### 5.2 Test wall

A rigid, vertical and plane surface.

### 5.3 Stops

Stops to prevent the article from sliding but not tilting, not higher than 12 mm except in cases where the design of the item necessitates the use of higher stops, in which case the lowest that will prevent the item from sliding shall be used.

### 5.4 Loading pad

A rigid cylindrical object, 50 mm in diameter, having a flat face with 12 mm radius on the edge.

### 5.5 Apparatus for slam open of extension elements

Two examples for a suitable apparatus as well as calibration instructions are given in annex A.

### 5.6 Dead loads

Masses shall be designed so that they do not reinforce the structure or redistribute the stresses.

Bags shall be divided into small compartments to prevent the contents from moving during the test.

## 5.7 Glass marbles

Marbles between 10 mm and 15 mm in diameter shall be used during the test described in 7.5 (slam open test of drawers). They shall be in a flexible bag large enough to allow them to move during the test.

## 5.8 Impact plate

A 1,7 kg impact plate, with a steel plate of 200 mm -109 mm -10 mm faced with a 3 mm thick layer of rubber with a hardness of  $(85 \pm 10)$  IRHD according to ISO 7619-2.

## 6 General safety requirements

Components or parts of the storage units and worktops of storage units with which the user may come into contact during normal use shall have no burrs and/or sharp edges, nor shall there be open-ended tubes.

To avoid the hazard of a pinching or scissoring action between moving parts accessible during normal use the distance between such parts shall be kept to less than  $\geq 8$  mm or greater than  $\geq 25$  mm in any position during movement, with the exception of doors (including hinges) and extension elements (including runners), but including the distance between handles and other parts.

In order to avoid pinching points for feet the safety height for vertically moving units shall be at least 100 mm from the floor.

All roll front doors sliding vertically shall not move by themselves from any position higher than 50 mm measured from the closed position if this can cause any injury.

All extension elements whose mass including contents exceeds 10 kg (see table 1) shall have effective open stops, i.e. they shall resist being pulled out of the carcass once by a force of 200 N applied to the handle of the loaded drawer or they shall be supplied with a label on the drawer's front, that the drawer can easily be pulled out.

Any external, vertical glass component  $\geq 0.1$  m<sup>2</sup> in area, where the smallest dimension is greater than or equal to 200 mm and any part of which is less than 900 mm above the floor, shall not break when tested according to EN 14072, when using a drop height of 60 mm or shall break as specified in EN 14072:2003, clause 7, C2 or C3.

At least two of the wheels or castors of movable units shall be lockable.

If high storage units are equipped with ladders, the ladders shall comply with the relevant requirements of EN 131-2.

The tests specified in clauses 7.1. 1; 7.2; 7.3.2; 7.5.2; 7.6.2; 7.7; 7.8; 8.1 and 8.2 are safety tests.

## 7 Test procedures and requirements

### 7.1 Shelves

#### 7.1.1 Stable positioning of shelves

All shelves shall be secured against falling out.

This requirement is fulfilled when the horizontal force applied to the middle of the front edge required to initiate movement of the unloaded shelf is more than 50 % of the weight of the unloaded shelf.

No unloaded shelf shall tip when a downward vertical force of 100 N is applied at any point 25 mm in from the front edge.

### 7.1.2 Deflection of shelves

Testing of the deflection of shelves, which are not made of metal, glass or stone, shall be carried out in a controlled humidity atmosphere (see 4.1).

Place the shelf on its supports in the unit.

The deflection of the shelf shall be measured at the front edge where it is greatest.

The deflection shall be measured to an accuracy of  $\pm 0,1$  mm with reference to a straight line parallel to the front edge drawn between two adjacent supports.

Load the shelf uniformly with the maximum load specified by the manufacturer or within the loads in Table 1 and apply for:

- one hour for shelves made of metal, glass and stone;
- one week for all other shelves.

At the same points as specified above, measure and record the deflection under load to an accuracy of  $\pm 0,1$  mm and as a percentage of the distance between the supports.

### 7.2 Shelf supports

All supports of the shelf for testing shall be tested.

For units with an indeterminate number of shelves, unless otherwise specified, divide the internal height of the article in millimetres by 300 and take the nearer integer. This number minus 1 shall then be the number of shelves to be fitted.

Load all components intended for storage purposes uniformly according to table 1.

**Table 1 — Required loads**

Shelves/flaps/bottoms	1,00 kg/dm <sup>2</sup>
Baskets with internal heights $\leq 100$ mm	0,65 kg/dm <sup>3</sup>
All other baskets	0,20 kg/dm <sup>3</sup>
Extension elements with $\leq 110$ mm clear height	0,35 kg/dm <sup>3</sup>
All other drawers	0,20 kg/dm <sup>3</sup>

For the shelf being tested, distribute the load uniformly, except at approximately 220 mm from one support, where the impact plate (5.8) shall be tipped over 10 times at a point as close to the support as possible (see Figure 1). The striking surface shall be that faced with rubber.

After the test the shelf supports and/or the shelf/carcass shall show no fracture or other damage that can affect the safety.

Dimensions in millimetres

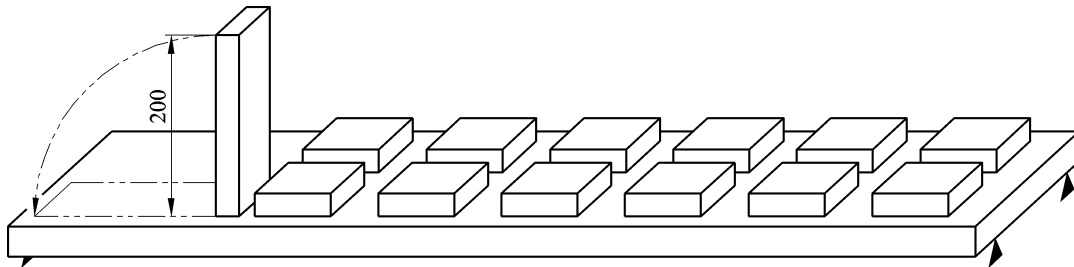

**Figure 1 — Strength test of shelf supports**

### 7.3 Pivoted doors

#### 7.3.1 General

These tests apply to all doors hinged to the carcass on one vertical side (incl. folding doors). Load all components intended for storage purposes uniformly according to Table 1.

#### 7.3.2 Strength of pivoted doors

Load the door as shown in Figure 2 with a load of 30 kg.

Swing the door 10 full cycles (back and forth) from a position  $45^\circ$  from fully closed to a position  $10^\circ$  from fully opened, but to a maximum of  $135^\circ$ .

Opening and closing can be done by hand using 3 s to 5 s for opening and 3 s to 5 s for closing.

#### 7.3.3 Horizontal static force on open door

Doors having a maximum opening angle of  $135^\circ$  or less, shall be tested as follows:

Apply a horizontal static force of 80 N to the fully opened door perpendicular to the plane of the door on its horizontal centre line 100 mm from the outer edge of the door in the direction of the opening. Apply the load 10 times.

Before and after the test, inspect the appearance and function of the unloaded door after using the adjustment provided.

There shall be no damage affecting function.

#### 7.3.4 Durability test on hinged and pivoted doors

Attach a weight with a mass of 2 kg (see figure 2) equally distributed on both sides of the door on the vertical centre line.

Swing the door 50,000 cycles (back and forth) without forcing the hinge in the open position from a position  $45^\circ$  from fully closed to a position  $10^\circ$  from fully opened, but to a maximum of  $135^\circ$ , the recommended rate is maximum 6 cycles per minute.

Any door closing catch mechanism fitted shall be operated at every cycle. Locking mechanisms are not included.

Before and after the test, inspect the appearance and function of the unloaded door after using any adjustment provided.

NOTE At the end of the test, the force required for opening and closing should not vary from more than 20 %.

### 7.3.5 Safety requirements

After the tests in 7.3.2 and 7.3.3 the door shall remain fully attached to the cabinet.

### 7.3.6 Durability requirement

After the tests in 7.3.2, 7.3.3 and 7.3.4 the function of the door shall not be impaired.

Dimensions in millimetres

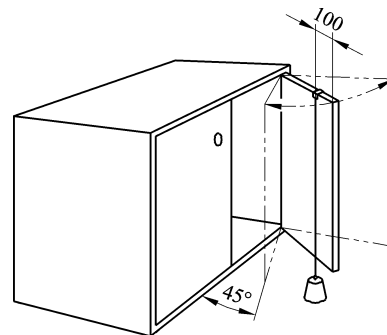

Figure 2 — Load test of pivoted doors

## 7.4 Sliding doors and horizontal roll fronts

### 7.4.1 General

This test applies to all doors sliding horizontally including those constructed from hinged elements. Load all components intended for storage purposes uniformly according to Table 1.

### 7.4.2 Slam open and shut

The door shall be opened/closed by means of a string or cord attached to the centre of the handle. If the handle has a length greater than 200 mm, the string shall be attached 100 mm below the top of the handle up to a maximum height from the floor of 1 200 mm (see Figure 3). If the door has no handle, the string shall be attached at middle of the door height, up to a maximum of 1 200 mm from the floor.

Determine the mass,  $W$ , required to just move the door. The test mass shall be 4 kg plus the mass  $W$ .

Close/open the door/roll front 10 times towards the fully closed/opened positions using the test mass ( $W + 4$  kg).

Start the movement 300 mm from the closed/opened positions respectively. The test mass shall be removed 10 mm before the door/roll front is fully closed/opened.

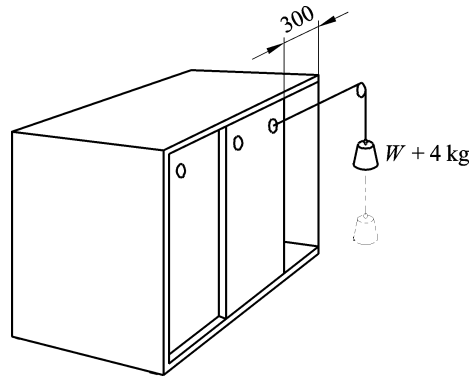

Figure 3 — Slam open/shut of sliding doors

#### 7.4.3 Durability test of sliding doors and horizontal roll fronts

Open and close the door or roll front gently 20,000 cycles from the fully closed position to a position 50 mm from the fully opened position. Apply the opening and closing force to the handle.

If the door/roll front has a catching device at any position, operate this mechanism at every cycle. Catching device does not include locking mechanism.

#### 7.4.4 Safety requirements

After the test in 7.4.2 the door shall still be retained within the carcass.

#### 7.4.5 Strength and durability requirements

After the tests in 7.4.2 and 7.4.3 the door and/or carcass shall show no fracture or damage and its function shall not be impaired.

### 7.5 Drawers and extension elements

#### 7.5.1 General

Load all components intended for storage purposes uniformly according to Table 1.

#### 7.5.2 Slam open test for drawers equipped with open stops

The slam open test applies to all types of extension elements with stops in the open position.

Place the extension element on its runners and load with glass marbles (5.7) according to Table 1. Close the extension element to a position 300 mm from the fully open position (or fully close the extension element if the travel is less than 300 mm).

Testing shall be carried out with an apparatus working according to one of the two methods specified in A1 and A2 in Annex A.

Apply the force to the handle or, in case of two handles in the middle between the handles. On extension elements without a handle apply the force at the same level as the runners.

The slamming force shall be applied until 10 mm before the extension elements reaches its end travel.

Slam the extension elements open 10 times.

### 7.5.3 Strength of drawers and extension elements

Open the test element to its open stops. If it is not fitted with open stops, open it to the point at which one-third of its inside length (depth) or at least 100 mm remains inside the carcass.

Apply a vertical force of 250N to one top corner of the drawer front.

The means for applying the force shall be such as not to inhibit deformation of the drawer.

The forces shall be applied until the full load has been reached or until the drawer front has deflected downwards to a point 100 mm below its horizontal position.

Maintain the load for a minimum of  $(10 \pm 2)$  s.

If the drawer is forced out of the carcass it shall be reassembled if necessary and returned to the carcass. This shall be recorded in the report.

Carry out the test for a total of ten times.

Before and after the test, inspect the function of the drawer.

### 7.5.4 Durability test of drawers and extension element

Open and close the drawer or extension element gently and without vertical support over its full distance of travel without forcing the stop in the open position for 50,000 cycles.

If a drawer is not equipped with open stops, open it to the point at which one-third of the inside length (depth) of the drawer, or at least 100 mm remains inside the carcass.

The operating force shall be applied at the position intended in normal use (i.e. the drawer handle), ensure no upwards or downwards force is applied to the drawer runners when closing the drawer.

Before and after the test, inspect the appearance and function of the drawer and runners. Measurements may be taken if this is necessary.

### 7.5.5 Displacement of drawer bottoms

Place the drawer on its runners, or suspend it in a similar way.

Apply a force of 70 N through the loading pad (5.4) approximately 25 mm above the bottom of the drawer, at the middle of the front and back of the drawer (see Figure 4). Apply the force 10 times and maintain it for at least  $(10 \pm 2)$  s at each time.

Before and after the test, inspect the appearance and function of the drawer.

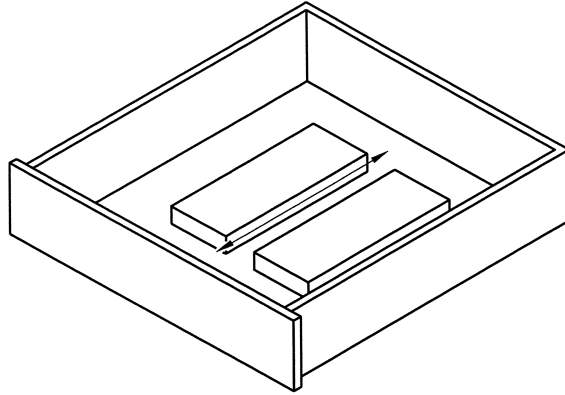

Figure 4 — Displacement of bottom surface of drawers

### 7.5.6 Safety requirements

During the test in 7.5.2 the drawer or parts of it shall not fall out of the cabinet.

### 7.5.7 Strength and durability requirements

After the tests in 7.5.2, 7.5.3, 7.5.4, and 7.5.5 there shall not be fracture or damage that impairs the function.

## 7.6 Flaps

### 7.6.1 General

This test only applies to flaps intended to be loaded when used in the open position, e.g. as a work surface.

Load all components intended for storage purposes uniformly according to Table 1.

### 7.6.2 Strength test

Load the flap vertically 10 times with 200 N as shown in Figure 5 using the loading pad (5.4). During each application maintain the load for  $(10 \pm 2)$  s.

Dimensions in millimetres

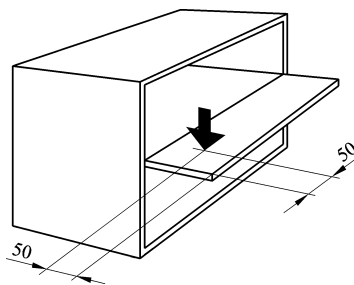

Figure 5 — Strength test of flaps



### 7.6.3 Durability test

Open and close the flap fully and gently 20,000 cycles. Use approximately 3 s for opening and 3 s for closing the flap.

If the flap has a catching device at any position, operate this mechanism at every cycle. Catching device does not include locking mechanism.

When the flap is fitted with an adjustable friction stay it shall be adjusted so that the flap will just open under its own weight and readjusted when necessary but not more than 10 times during the test (4.2).

Before and after the test, inspect the appearance and function of the flaps, hinges etc. readjusting if possible. Measure the braking force of any friction stay without adjustable friction before and after the test and report the differences.

### 7.6.4 Safety requirements

After the test in 7.6.2 the flap shall remain fully attached to the cabinet.

### 7.6.5 Strength and durability requirements

After the tests in 7.6.2, and 7.6.3 there shall not be fracture or damage that impairs the function.

## 7.7 Static load on top surfaces of storage units

### 7.7.1 Top Surfaces

This test only applies to all top surfaces which are  $\leq 100$  mm above the floor surface.

Load all components intended for storage purposes uniformly according to Table 1.

Load the work top vertically 10 times with 1 000 N at the position most likely to cause failure using the loading pad (5.4) but not less than 50 mm from the edge.

During each application maintain the load for  $(10 \pm 2)$  s.

### 7.7.2 Safety requirements

After the test the work top and/or carcass shall show no fracture or damage that can affect the safety.

Hinged or sliding worktops shall also be tested according to 7.5 or 7.6.

## 7.8 Wall and top mounted units

### 7.8.1 General

The unit shall be mounted according to the manufacturer's installation instructions. Where the manner of mounting is not unambiguously defined, the manner of mounting shall be recorded.

Adjustable wall attachment devices shall be set in the position most likely to cause failure.

NOTE This position will normally be when adjusted to the maximum depth (as far from the wall as possible) and to the height adjustment range and when devices used for levelling adjustments are placed as low and as far apart as possible.

### 7.8.2 Tests on movable parts, shelf supports and top surfaces

As soon as possible after the loading, carry out the following tests, if applicable:

Clause 7.2 Shelf supports;

Clause 7.3 Pivoted doors;

Clause 7.4 Sliding doors and horizontal roll fronts (slam shut and open); Clause 7.5 Drawers and extension elements;

Clause 7.6 Flaps;

Clause 7.7 Top surfaces.

The tests shall always be carried out on that part most likely to cause failure to the wall attachment.

### 7.8.3 Overload

After carrying out the tests on the movable parts, increase the load on all the storage areas according to the following principle.

If the number of shelves is not determined by the structure of the unit, divide the internal height, see 7.2 of EN 14749:2005 of the unit in mm by 300 and take the lower integer. This number shall then be the number of shelves to be used during testing:

The load on the bottom shall be 250 kg/m<sup>2</sup>;

load on the first shelf shall be 150 kg/m<sup>2</sup>;

load on the second shelf shall be 100 kg/m<sup>2</sup>;

load on the third and following shelves shall be 65 kg/m<sup>2</sup>; and

load on the top surface shall be 50 kg/m<sup>2</sup>.

If the volume of the unit, calculated by the inner width, depth and height, is greater than 0,225 m<sup>3</sup>, the loads shall be multiplied by the factor R

$$R = \frac{1,2}{(0,75 + 2V)} \quad (1)$$

where

V in m<sup>3</sup> is the volume of the unit in m<sup>3</sup>. An example of the calculation is shown in Annex B (informative.)

When reduction of the load is necessary; it shall be removed from the bottom.

The loading time shall be one week.

### 7.8.4 Safety requirements

After the tests listed in 7.8.2 and 7.8.3 the unit shall remain attached as mounted and shall support the test load specified in 7.8.3.

## 8 Stability

### 8.1 Stability with closed drawers and doors

Free-standing units with worktops shall, when unloaded, not overturn when an outwards overturning moment of 200 Nm is applied.

During testing, all doors, flaps and extension elements shall be closed.

### 8.2 Stability with open drawers, flaps and doors

Free-standing units, combinations of units and underbench units on castors shall not overbalance when doors, flaps or drawers are opened without defeating interlocks. During testing all drawers shall be loaded with the maximum load specified by the manufacturer or with the loads according to Table 1.

## 9 Additional safety requirements for underbench cabinets on castors

### 9.1 Retention of drawers on sudden cessation of movement of unit

Cabinets equipped with castors shall have a means of retaining all drawers in the closed position when the unit is moved.

### 9.2 Stopping device

Place the cabinet on a floor sloping at an angle of 5° to the horizontal and apply the stopping devices on two castors only.

Load the cabinet either with the maximum load specified by the manufacturer or in accordance with Table 1.

Check whether the cabinet moves down the sloping floor in the loaded or unloaded condition when no horizontal force is applied.

### 9.3 Safety requirements

The unit shall not move when tested according to 9.2.

## 10 Installation instructions

Each wall and top mounted cabinet shall be supplied with installation instructions. The instructions shall contain at least the following information in the language of the country, where the furniture is sold:

- a) warning of danger if incorrectly installed;
- b) installation only to be carried out by a competent person;
- c) need to check the suitability of the wall/ceiling and to check that the fastening devices will withstand the forces generated.

For self assembly furniture the following additional information is required:

- d) list of parts supplied;
- e) list of tools required; and
- f) diagram of the bolts and other fastenings required.

## 11 Test report

The test report shall include the following items:

- a) reference to this European Standard;
- b) details of the furniture tested;
- c) any defects observed before testing;
- d) test results according to the applicable clauses;
- e) details of any deviations from the test procedures, specified in this European Standard;
- f) name and address of the test facility;
- g) date of test.

## Annex A (normative)

### A.1 Slam open test of extension elements

#### A.1.1. Principle

Lightweight (empty) extension elements are slammed at consistently higher speeds than heavy (full) extension elements, but friction does not significantly affect the slamming speed.

Standard "empty" (5 kg) and "full" (35 kg) extension elements with minimal friction are used to simulate these conditions. Using these extension elements the speed of the extension element slamming apparatus is adjusted to the slamming velocities specified.

#### A.1.2 Apparatus

A suitable apparatus for slam open tests of extension elements consists of a pneumatically actuated low-friction piston/cylinder with a means of regulating the pressure of air supplied from a reservoir. The air-flow between the piston/cylinder and the reservoir is controlled by an air-operated valve which allows the air stored in the reservoir to be connected to the piston/cylinder rapidly, when the control valve is operated. The rate of flow is controlled by the incorporation of connecting tubing of specified bores and lengths, (See Figure A.1).

#### A.1.3 Calibration

Using two standard extension elements, having masses of 5 kg and 35 kg respectively, and exhibiting a total frictional force in the runners of not greater than 10 N, calibrate the apparatus to produce opening velocities of 1,3 m/s for 5 kg and 1,0 m/s for 35 kg.

The apparatus shall be calibrated so that the slamming velocities of the calibration drawers are:

1,3 m/s for a 5 kg drawer; and

1,0 m/s for a 35 kg drawer.

NOTE A linear relationship is assumed from 5 kg to 35 kg mass drawers.

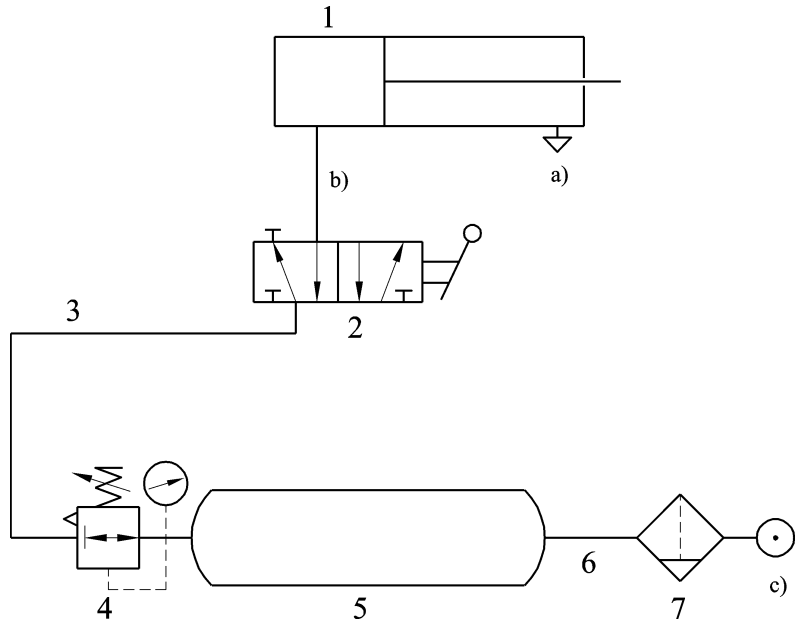

**Key**

- 1 Cylinder ( $\Delta$  40 mm, s = 300 mm)
  - 2 Valve (nominal air flow > 900 l/min)
  - 3 Tube (bore 6 mm, length 720 mm)
  - 4 Pressure regulator (nominal air flow > 900 l/min)
  - 5 Air reservoir (radius 37,5 mm; length 350 mm; volume 1 545,6 cm<sup>3</sup>)
  - 6 Tube (bore 3 mm, length 1 040 mm)
  - 7 Air cleaner
- a) Free outlet  
 b) Valve to be mounted directly on cylinder  
 c) Primary pressure 6 bar

**Figure A.1 — Circuit diagram for pneumatic drawer slamming apparatus**

## A.2 Slam open test with weight and string

### A.2.1 Slam open test

The extension element shall be opened by a hanging weight ( $m$ ) that is attached to the extension element by means of string or cord. The force exerted by the weight is removed 10 mm before the extension element reaches its endstops. The movement is started 300 mm from fully opened position.

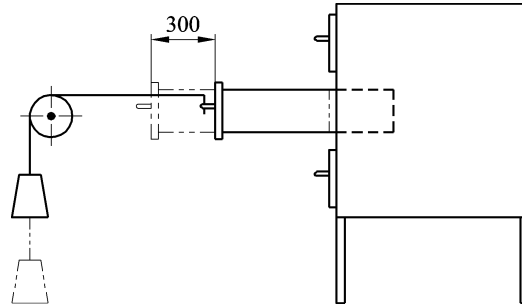

Figure A.2 — Extension element slamming apparatus with hanging weight

The mass ( $m$ ) of the hanging weight is calculated by the following formula:

$$m = 2,5^3 \sqrt{M} \quad (2)$$

where:

$M$  is the total mass of the extension element.

NOTE This system produces the same slam velocities as specified in A.1.3.

## Annex B (informative)

### Example of loading of wall hanging units (see 7.8.3 Overload)

Wall hanging unit with internal dimensions:

- width: 1,00 m
  - depth: 0,35 m
  - height: 0.85 m
- = 0.30 m<sup>3</sup> volume

Number of shelves = internal height/200 = 4,25. This means 3 shelves with an area of 0,35 m<sup>2</sup> each. According to this the following loads applies:

$$\text{Bottom} = 0,35 \text{ m}^2 \times 250 \text{ kg/m}^2 = 87,50$$

$$\text{First shelf:} = 0,35 \text{ m}^2 \times 150 \text{ kg/m}^2 = 52,50$$

$$\text{Second shelf} = 0,35 \text{ m}^2 \times 100 \text{ kg/m}^2 = 35,00$$

$$\text{Third shelf} = 0,35 \text{ m}^2 \times 65 \text{ kg/m}^2 = 22,75$$

$$\text{Top surface} = 0,35 \text{ m}^2 \times 50 \text{ kg/m}^2 = 17,50$$

$$\text{Test load without load reduction:} = 215,25 \text{ kg}$$

Because of the inner volume of 0,30 m<sup>3</sup> a reduction of the load is required:

$$\text{Reduction factor } R = \frac{1,2}{(0,75 + 2 v)} = \frac{1,2}{(0,75 + 2 \times 0,30)} = 0,89 \quad (3)$$

$$\text{Reduction test load:} = 215,25 \times 0,89 = 191,57 \text{ kg}$$

$$\text{Reduction of bottom load:} = 215,25 - 191,57 = 23,68 \text{ kg}$$

$$\text{Reduced test load of bottom:} = 87,5 - 23,68 = 63,82 \text{ kg}$$





---

---

## BSI — British Standards Institution

BSI is the independent national body responsible for preparing British Standards. It presents the UK view on standards in Europe and at the international level. It is incorporated by Royal Charter.

### Revisions

British Standards are updated by amendment or revision. Users of British Standards should make sure that they possess the latest amendments or editions.

It is the constant aim of BSI to improve the quality of our products and services. We would be grateful if anyone finding an inaccuracy or ambiguity while using this British Standard would inform the Secretary of the technical committee responsible, the identity of which can be found on the inside front cover.  
Tel: +44 (0)20 8996 9000. Fax: +44 (0)20 8996 7400.

BSI offers members an individual updating service called PLUS which ensures that subscribers automatically receive the latest editions of standards.

### Buying standards

Orders for all BSI, international and foreign standards publications should be addressed to Customer Services. Tel: +44 (0)20 8996 9001.  
Fax: +44 (0)20 8996 7001. Email: [orders@bsi-global.com](mailto:orders@bsi-global.com). Standards are also available from the BSI website at <http://www.bsi-global.com>.

In response to orders for international standards, it is BSI policy to supply the BSI implementation of those that have been published as British Standards, unless otherwise requested.

### Information on standards

BSI provides a wide range of information on national, European and international standards through its Library and its Technical Help to Exporters Service. Various BSI electronic information services are also available which give details on all its products and services. Contact the Information Centre.  
Tel: +44 (0)20 8996 7111. Fax: +44 (0)20 8996 7048. Email: [info@bsi-global.com](mailto:info@bsi-global.com).

Subscribing members of BSI are kept up to date with standards developments and receive substantial discounts on the purchase price of standards. For details of these and other benefits contact Membership Administration.  
Tel: +44 (0)20 8996 7002. Fax: +44 (0)20 8996 7001.  
Email: [membership@bsi-global.com](mailto:membership@bsi-global.com).

Information regarding online access to British Standards via British Standards Online can be found at <http://www.bsi-global.com/bsonline>.

Further information about BSI is available on the BSI website at <http://www.bsi-global.com>.

### Copyright

Copyright subsists in all BSI publications. BSI also holds the copyright, in the UK, of the publications of the international standardization bodies. Except as permitted under the Copyright, Designs and Patents Act 1988 no extract may be reproduced, stored in a retrieval system or transmitted in any form or by any means – electronic, photocopying, recording or otherwise – without prior written permission from BSI.

This does not preclude the free use, in the course of implementing the standard, of necessary details such as symbols, and size, type or grade designations. If these details are to be used for any other purpose than implementation then the prior written permission of BSI must be obtained.

Details and advice can be obtained from the Copyright & Licensing Manager.  
Tel: +44 (0)20 8996 7070. Fax: +44 (0)20 8996 7553.  
Email: [copyright@bsi-global.com](mailto:copyright@bsi-global.com).