

Determination of the elasticity of fabrics —

Part 3: Narrow fabrics

The European Standard EN 14704-3:2006 has the status of a
British Standard

ICS 59.080.30

National foreword

This British Standard was published by BSI. It is the UK implementation of EN 14704-3:2006.

The UK participation in its preparation was entrusted to Technical Committee TCI/24, Physical testing of textiles.

A list of organizations represented on TCI/24 can be obtained on request to its secretary.

This publication does not purport to include all the necessary provisions of a contract. Users are responsible for its correct application.

Compliance with a British Standard cannot confer immunity from legal obligations.

This British Standard was published under the authority of the Standards Policy and Strategy Committee on 31 January 2007

© BSI 2007

ISBN 978-0-580-49964-7

Amendments issued since publication

Amd. No.	Date	Comments

ICS 59.080.30

English Version

Determination of the elasticity of fabrics - Part 3: Narrow fabrics

Détermination de l'élasticité des étoffes - Partie 3 : Etoffes étroites

Bestimmung der Elastizität von Flächengebilden - Teil 3: Schmaltextilien

This European Standard was approved by CEN on 28 October 2006.

CEN members are bound to comply with the CEN/CENELEC Internal Regulations which stipulate the conditions for giving this European Standard the status of a national standard without any alteration. Up-to-date lists and bibliographical references concerning such national standards may be obtained on application to the Central Secretariat or to any CEN member.

This European Standard exists in three official versions (English, French, German). A version in any other language made by translation under the responsibility of a CEN member into its own language and notified to the Central Secretariat has the same status as the official versions.

CEN members are the national standards bodies of Austria, Belgium, Cyprus, Czech Republic, Denmark, Estonia, Finland, France, Germany, Greece, Hungary, Iceland, Ireland, Italy, Latvia, Lithuania, Luxembourg, Malta, Netherlands, Norway, Poland, Portugal, Romania, Slovakia, Slovenia, Spain, Sweden, Switzerland and United Kingdom.



EUROPEAN COMMITTEE FOR STANDARDIZATION
COMITÉ EUROPÉEN DE NORMALISATION
EUROPÄISCHES KOMITEE FÜR NORMUNG

Management Centre: rue de Stassart, 36 B-1050 Brussels

Contents

Page

Foreword.....	3
1 Scope	4
2 Normative references	4
3 Terms and definitions	4
4 Principle.....	6
4.1 Method A.....	6
4.2 Method B.....	6
5 Sampling.....	6
6 Apparatus	6
6.1 CRE testing machine.....	6
6.2 Line clamps	7
6.3 Equipment, for cutting test specimens to the required dimensions.....	7
6.4 Calibrated metal rule, graduated in mm.	7
7 Atmosphere for conditioning and testing	7
8 Preparation of test specimens	7
8.1 General.....	7
8.2 Test specimen preparation	7
9 Procedure	7
9.1 Method A.....	7
9.2 Method B.....	10
10 Test report	14
Annex A (informative) Example of a typical cycling graph for method A.....	15
Annex B (informative) Procedure for sampling.....	16
Annex C (informative) Clamping and holding devices	17

Foreword

This document (EN 14704-3:2006) has been prepared by Technical Committee CEN/TC 248 "Textiles and textile products", the secretariat of which is held by BSI.

This European Standard shall be given the status of a national standard, either by publication of an identical text or by endorsement, at the latest by June 2007, and conflicting national standards shall be withdrawn at the latest by June 2007.

The reasons behind developing this standard are due to technical advancement in yarn and fabric structures and properties, which increases product range and developments.

According to the CEN/CENELEC Internal Regulations, the national standards organizations of the following countries are bound to implement this European Standard: Austria, Belgium, Cyprus, Czech Republic, Denmark, Estonia, Finland, France, Germany, Greece, Hungary, Iceland, Ireland, Italy, Latvia, Lithuania, Luxembourg, Malta, Netherlands, Norway, Poland, Portugal, Romania, Slovakia, Slovenia, Spain, Sweden, Switzerland and United Kingdom.

1 Scope

This standard describes the test methods which can be used to measure the elasticity and related properties of narrow fabrics. Two methods are itemised: one for the purpose of product quality assurance (method A), and the other for product performance when in use (method B).

2 Normative references

The following referenced documents are indispensable for the application of this document. For dated references, only the edition cited applies. For undated references, the latest edition of the referenced document (including any amendments) applies.

EN ISO 139, *Textiles – Standard atmospheres for conditioning and testing (ISO 139:2005)*

EN ISO 7500-1, *Metallic materials – Verification of static uniaxial testing machines – Part 1: Tension/compression testing machines – Verification and calibration of the force-measuring system (ISO 7500-1:2004)*

EN ISO 10012, *Measurement management systems - Requirements for measurement processes and measuring equipment (ISO 10012:2003)*

3 Terms and definitions

For the purposes of this European standard the following terms and definitions apply.

- 3.1 narrow fabric**
woven or knitted construction intended for use as a trim, binding, edging, strapping or harness, and designed to be used in its full width
- 3.2 elasticity**
property of a material by virtue of which it tends to recover its original size and shape immediately after removing the force causing deformation
- 3.3 constant-rate-of-extension (CRE) testing machine**
tensile testing machine provided with one clamp which is stationary and another clamp, which moves with a constant speed throughout the test, the entire testing system being virtually free from deflection
- 3.4 strip test specimen**
test specimen in which the full width is gripped in the jaws of the testing machine
- 3.5 gauge length**
distance between the two effective clamping points of a testing device, for this method where line clamps are employed, it is the distance between the two contact points
- 3.6 slack mounting**
insertion of a strip test specimen in the line clamps of the upper jaw, allowing it to hang freely under its own weight, guided by the hand to ensure perpendicular alignment to the line of pulling force, without any force being applied

3.7**initial length**

length of the test specimen between the two effective clamping points, before testing

3.8**extension**

increase in length of a test specimen produced by a force as a result of testing, expressed in mm

3.9**elongation**

ratio of the extension of the test specimen to its initial length, expressed as a %

3.10**maximum force**

force recorded in N at the position when a test specimen is taken to a fixed extension

3.11**maximum extension**

extension recorded in mm at the position when a test specimen is taken to a fixed load

3.12**modulus**

force measured at a given elongation on either the load or unload curves

3.13**cycle**

process whereby a fabric is taken from the gauge length to a fixed load or fixed extension or elongation, and returned to gauge length

3.14**force decay due to time**

loss of force measured over time when a test specimen is stretched to a specified elongation or force and held in this position for a given time period

NOTE The decay in force is expressed as a % of the original force recorded at the specified position (see Annex A).

3.15**force decay due to exercising**

loss of force, calculated and expressed as a percentage, as measured and recorded at the same elongation point on two different cycles when the test specimen is cycled several times between zero and a specified elongation (see Annex A)

3.16**un-recovered elongation**

ratio of the unrecovered extension of the test specimen after cycling, to a specified force or extension, to its initial length, expressed as a %

3.17**recovered elongation**

unrecovered elongation, expressed as a %, subtracted from 100 %

3.18**elastic recovery**

recovered elongation expressed as a % of the total elongation

4 Principle

4.1 Method A

A narrow test specimen of specified length dimensions is extended at a constant rate to a specified force for an agreed number of cycles. Several characteristics can be measured to determine the performance and profile of the narrow fabric.

4.2 Method B

A narrow test specimen of specified length dimensions is extended at a constant rate to a specified force and elongation for 1 cycle of a specified sequence. Characteristics are measured to show the performance of the narrow fabric in use.

5 Sampling

Narrow fabric samples shall be selected in accordance with the product specification. In the absence of a product specification for the fabric, the sampling method given in Annex B may be used.

6 Apparatus

6.1 CRE testing machine

Metrological confirmation system of the tensile testing machine shall be in accordance with EN ISO 10012.

The constant-rate-of-extension testing machine shall conform to the following:

- a) Tensile testing machine shall be provided with the means for indicating or recording the force and elongation values when cycling between gauge length and either a fixed load or fixed extension. Under conditions of use, the accuracy of the apparatus shall be at least class 1 of EN ISO 7500-1. The error of the indicated or recorded maximum force at any point in the range in which the machine is used shall not exceed 1 %, and the error of the indicated or recorded jaw separation shall not exceed 1 mm.
- b) If recording of force or elongation is obtained by means of data acquisition boards and software, the frequency of data collection shall be at least 8/sec.
- c) Machine shall be capable of constant rates of extension including 20 mm/min to 500 mm/min with an accuracy of (\pm) 10 %.
- d) Machine shall be capable of variable gauge length settings including 100 mm to 250 mm, to an accuracy of (\pm) 1 mm.
- e) Clamping or holding devices shall be positioned with the centre in line with the applied force. The machine shall be calibrated, where applicable, with the grips in position and the jaw faces closed.

The jaws shall be capable of holding the test specimen without allowing it to slip and designed so that they do not cut or otherwise weaken the test specimen.

6.2 Line clamps

Line clamps, as shown in Figure C.1, shall consist of two jaws, one being of steel plate, the other having a convex 3 mm radius. The line of contact of the jaws shall be perpendicular to the line of increasing force. The clamping faces shall be in the same plane. The line clamp jaws shall not be less than the width of the test specimen and preferably have a width of (70 ± 6) mm.

NOTE 1 Significant levels of work have shown this type of line clamp is the preferred type for elastane/elastodiene containing fabrics as fabric slippage is eliminated. If a fabric slips the elongation values are inaccurate.

NOTE 2 Pneumatic operated grips are recommended as hand tightening or manual grips can cause distortion of the test specimen. The air pressure should be sufficient to prevent slippage but should not cut or otherwise weaken the test specimen.

6.3 Equipment, for cutting test specimens to the required dimensions.

6.4 Calibrated metal rule, graduated in mm.

7 Atmosphere for conditioning and testing

The atmospheres for pre-conditioning, conditioning and testing shall be as specified in EN ISO 139.

The narrow fabric samples shall be conditioned for a minimum of 20 h in a tension free state.

8 Preparation of test specimens

8.1 General

A set of test specimens from each laboratory sample, shall be cut in the length direction.

A set shall consist of a minimum of five test specimens. If the sample is supplied on role and of sufficient length, remove and discard the first 500 mm. Cut the required number of specimens to the correct length, rejecting a minimum of 300 mm in between each of the specimens.

8.2 Test specimen preparation

For method A and method B, each test specimen shall be cut to a length of 150 mm.

NOTE If for method A unrecovered elongation is determined at the end of the test, place (100 ± 1) mm reference (bench) marks centrally and perpendicular to the specimen length.

9 Procedure

9.1 Method A

9.1.1 General

9.1.1.1 Locate the line clamps in the jaws of the tensile testing machine and set the gauge length to (100 ± 1) mm. Check this gauge length setting using carbon paper and paper which will generate gauge (bench) marks on the paper. The distance is measured with the calibrated rule.

9.1.1.2 Set the extension and retraction rate of the specimen at 500 mm/min.

9.1.1.3 Set the required cycling limits to between gauge length and the appropriate load as given in Table 1. Load is determined according to the narrow mass/ml.

Table 1 — Loads and masses to be used in measuring elasticity properties

Fabric mass at the specimen width (g/m)	Loading (N)
Up to 2,0	7,5
2,01 to 3,75	12,0
3,76 to 5,00	15,0
5,01 to 7,50	25,0
7,51 to 11,0	34,0
11,01 to 17,00	42,0
17,01 to 25,00	53,0
25,01 to 36,00	61,0
> 36,00	74,0
Bra straps	35,0

9.1.1.4 Slack mount the specimen centrally between the two sets of line clamps.

9.1.2 Operation

NOTE 1 Many of the parameters measured can be determined by manual analysis of graphs and by software data collection procedures. It is recommended that assessment of the individual software be carried out to establish accuracy of the data collected.

Engage the device for recording the force and elongation measurements required. Put the cross-head in motion and cycle the test specimen between gauge length and the required force for the agreed number of cycles.

If it is required to determine force decay due to time, set the CRE testing machine to 'hold' at the maximum force on the final curve for the chosen period.

NOTE 2 Recommended period is 1 min.

If it is required to determine the Un-recovered elongation, remove the test specimen carefully from the CRE testing machine and lay on a flat surface for a chosen period. Re-measure the distance between the reference marks previously made on the specimen, using the calibrated steel rule. Handling of the test specimen shall be kept to a minimum to avoid variations in results.

NOTE 3 Recommended recovery periods are 1 min and 30 min.

9.1.3 Recording

Record the extension and/or elongation at the maximum force, from the curves or data generated in the test, as agreed between the relevant parties.

Record the modulus at any elongation point along the load or unload curves as agreed between the relevant parties.

9.1.4 Expressions and calculations of test results

The following values shall, where applicable, be calculated from the data recorded during the test.

Elongation, S , expressed as a %:

$$S = \frac{E - L}{L} \times 100 \quad (1)$$

where

E is the extension (mm) at maximum force on the final cycle (E.g. 5th cycle);

L is the initial length (mm).

Force decay due to time, A , expressed as a %:

$$A = \frac{V - W}{V} \times 100 \quad (2)$$

where

V is the maximum force from the final cycle;

W is the maximum force on the final cycle, after a specified holding period.

Force decay due to exercising, B , expressed as a %:

$$B = \frac{X - Y}{X} \times 100 \quad (3)$$

where

X is the maximum force at the specified elongation on an initial (specified) cycle;

Y is the maximum force at the same specified elongation on a subsequent (specified) cycle.

Un-recovered elongation, C , expressed as a %:

$$C = \frac{Q - P}{P} \times 100 \quad (4)$$

where

Q is the distance between applied reference marks (mm) after a specified recovery period;

P is the initial distance between applied reference marks (mm).

Recovered elongation, D , expressed as a %:

$$D = (100 - C) \quad (5)$$

Elastic recovery, R , expressed as a %:

$$R = \frac{D}{S} \times 100 \quad (6)$$

9.2 Method B

9.2.1 General

9.2.1.1 Locate the line clamps in the jaws of the tensile testing machine and set the gauge length to (100 ± 1) mm. Check this gauge length setting using carbon paper and paper, which will generate gauge (bench) marks on the paper. The distance is measured with the calibrated rule.

9.2.1.2 Set the extension and retraction rate of the specimen at 500 mm/min.

9.2.1.3 Conduct a preliminary test by slack mounting a test specimen centrally between the two sets of line clamps. Produce a single load and unload cycle taking the sample beyond the point of its available stretch region (see Figure 1).

NOTE An additional specimen should be prepared in order to carry out this preliminary test.

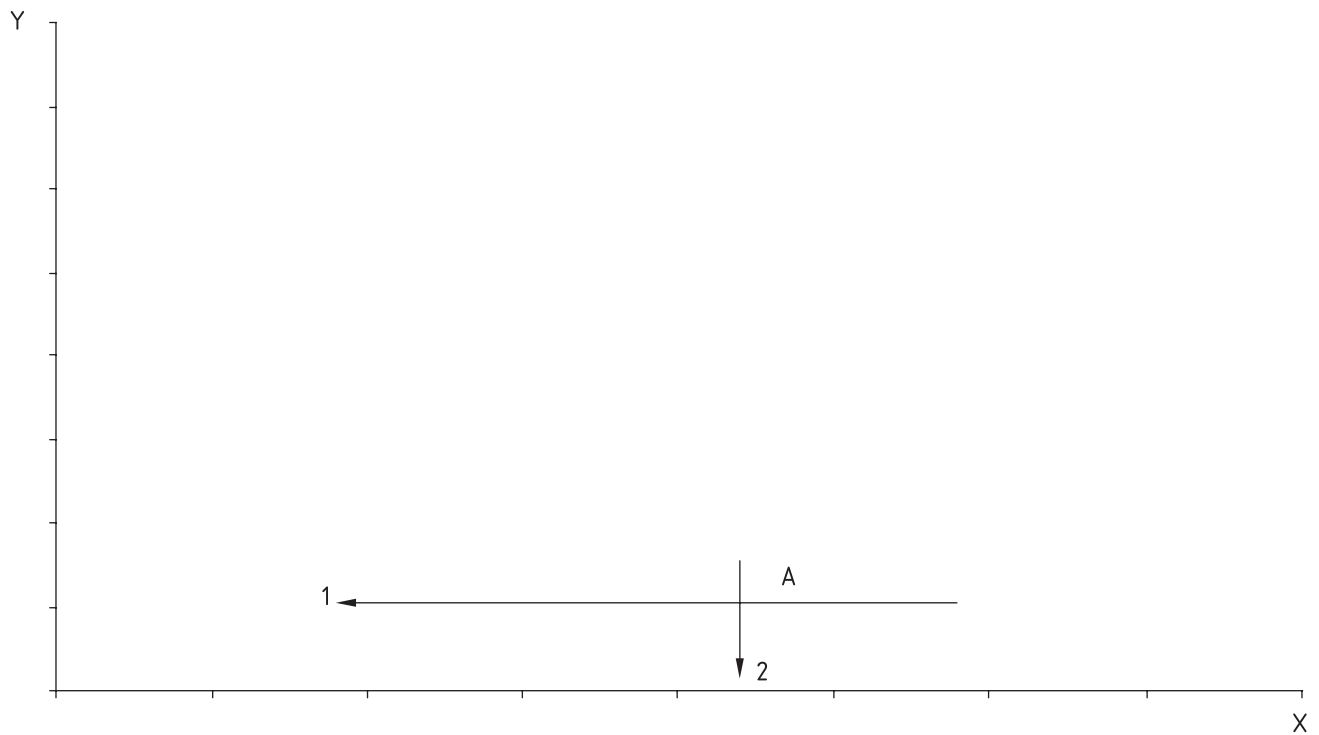
**Key**

X = Elongation
Y = Force
A = Origin point
1 = Modulus (N) at A
2 = Elongation (%) at A

Figure 1 — Preliminary test

9.2.1.4 Determine the modulus at origin point A, beyond which the narrow is not recoverable and record the force 1 and elongation 2 values at this point.

9.2.1.5 Establish from Table 2 the test parameters for the main test.

Table 2 — Parameters

Elongation (%)		Loading (N)		
Preliminary test	Elongation for main test	Preliminary test modulus point A	Loading for main test	
Modulus point A	Elongation to point (b)		Pretension (a)	Loading/Force (d)
If elongation is 50 %	10 %	If the load is < 15 N	0,15 N	15 N
If elongation is > 50 % but < 80 %	30 %	If the load is ≥ 15 N but < 30 N	0,30 N	30 N
If elongation is > 80 % but < 120 %	50 %	If the load is >30 N but <50N	0,50 N	50 N
If elongation is > 120 %	80 %	If the load is ≥ 50 N but < 70 N	0,70 N	70 N
If elongation is > 120 %	80 %	If the load is ≥ 70 N	1,00 N	100 N

9.2.2 Operation

Mount the first specimen centrally between the two sets of line clamps. Apply the pretension (a), equal to $(1 \pm 0,25)$ % of the maximum force to be applied during the test (see Table 2).

Engage the device for recording the force and elongation measurements required, put the cross-head in motion and conduct a cycle to the following sequence:

- extend the specimen to the elongation setting (b) as given in Table 2;
- return the cross-head so the specimen is extended to half elongation (b), point (c) in Figure 2;
- extend the specimen to the maximum force (d) as give in Table 2;
- return the cross-head again recording the force at the reference point, half elongation (b).

Repeat this for the remaining test specimens.

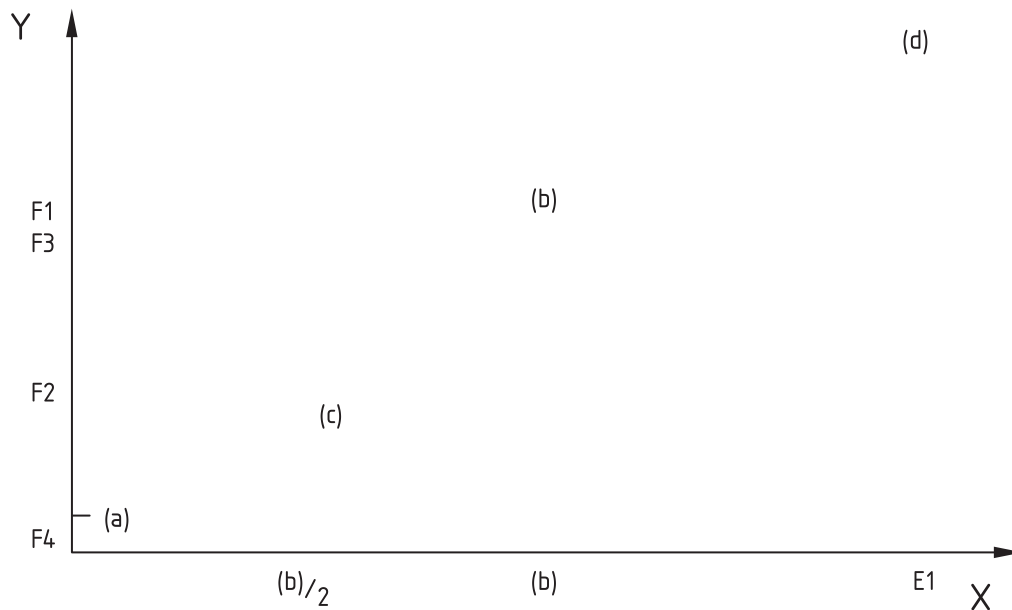
**Key**

X = Elongation

Y = Force

Figure 2 — Description of the cycle sequence (informative illustration)

9.2.3 Recording

Record the following values, forces in N and elongation as a %:

- F1 force when the specimen is extended to elongation (b);
- F2 force when the specimen is returned (on the retraction curve) to half elongation (b), at point (c);
- F3 force at point (b) when the specimen is being extended to maximum force (d);
- E1 elongation at maximum force point (d);
- F4 force at point (c), half elongation (b) (on the retraction curve).

9.2.4 Expressions and calculations of test results

Calculate the mean of the forces recorded for F1, F2, F3 and F4 and the mean percentage for elongation E1.

10 Test report

The test report shall include the following information:

- a) reference to this part of EN 14704-3 and the date of the test;
- b) method used, A or B;
- c) identification of the test sample and sampling procedure, if required;
- d) gauge length used, in mm;
- e) rate of extension used in mm/min;
- f) number of test specimens, particularly if less than 5;
- g) width of the specimen;
- h) any deviation from this procedure;
- i) maximum cycling force;
- j) arithmetic mean of the maximum extension and/or elongation, whichever is required and for which cycle;
- k) arithmetic mean of the modulus, the elongation point and cycle;
- l) arithmetic mean of the force decay – due to time and relevant cycles, when required;
- m) arithmetic mean of the force decay – due to exercising and the relevant cycles, when required;
- n) arithmetic mean of un-recovered elongation, when required;
- o) arithmetic mean of recovered elongation, when required;
- p) if required, the coefficient of variation for the relevant measured and calculated values;
- q) if required, the 95 % confidence limits of the relevant measured and calculated values.

Annex A (informative)

Example of a typical cycling graph for method A

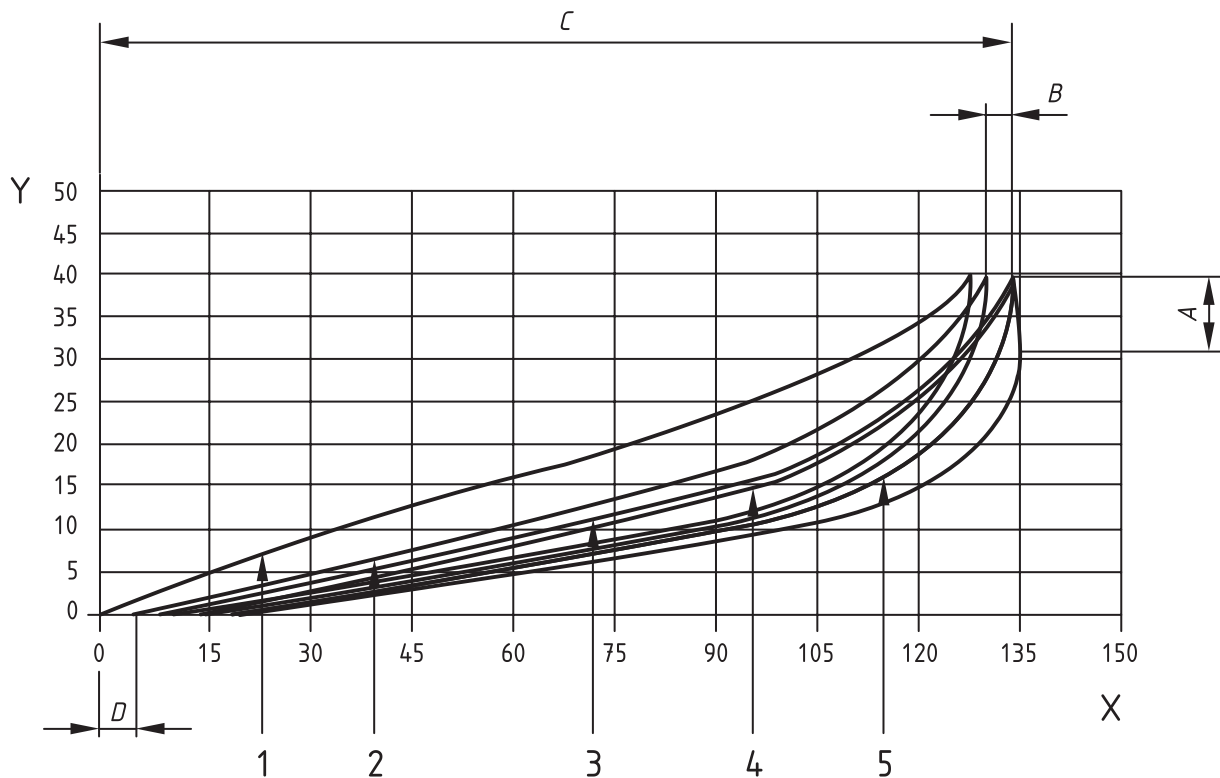

Key

A Force decay due to time	1 Pre-cycle
B Force decay due to exercising	2 Second load cycle
C Maximum extension	3 Fifth load cycle
D Un-recovered elongation	4 Sixth load cycle
	5 Fifth unload cycle

Figure A.1 — Typical cycling graph for method A

Annex B (informative)

Procedure for sampling

B.1 Bulk sample (number of pieces from a shipment or lot)

The appropriate number of pieces should be taken at random from the shipment or lot as specified in Table B.1, to form the bulk sample. No piece that shows signs of damage or dampness incurred during transit should be included in the sample.

Table B.1 — Bulk sample

Number of pieces In shipment or lot	Number of pieces in bulk sample, minimum
3 or less	1
4 to 10	2
11 to 30	3
31 to 75	4
76 or more	5

B.2 Number of laboratory samples

From each piece in the bulk sample, a laboratory sample should be cut from a position taken at random but at least 3 m from an end of the piece. The laboratory sample should be cut to include the full width of the piece and should have a length of at least 1 m. Areas that are creased or that have a visible fault should not be included in the sample.

Annex C (informative)

Clamping and holding devices

Dimensions in millimetres

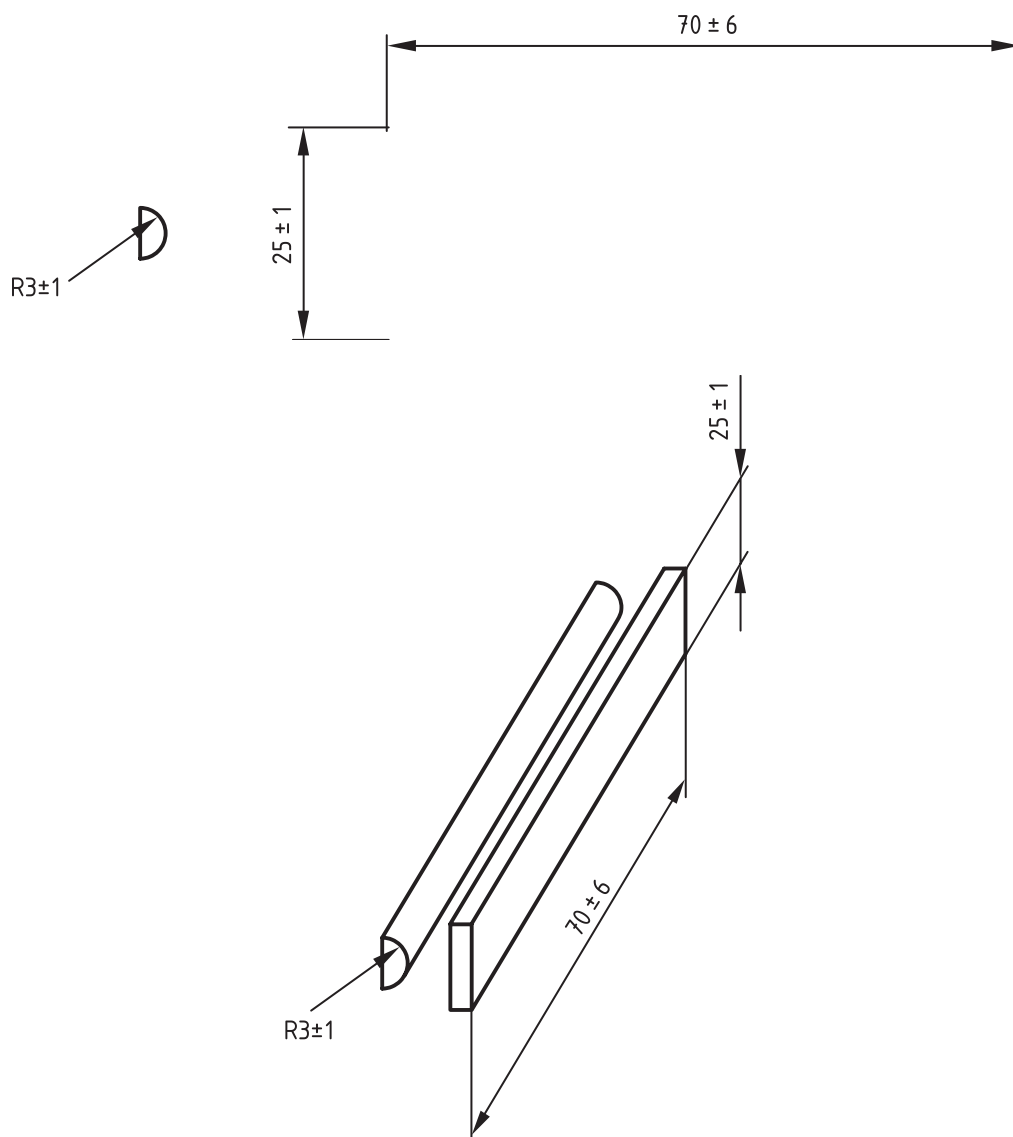
**Figure C.1 — Line clamps**

BSI — British Standards Institution

BSI is the independent national body responsible for preparing British Standards. It presents the UK view on standards in Europe and at the international level. It is incorporated by Royal Charter.

Revisions

British Standards are updated by amendment or revision. Users of British Standards should make sure that they possess the latest amendments or editions.

It is the constant aim of BSI to improve the quality of our products and services. We would be grateful if anyone finding an inaccuracy or ambiguity while using this British Standard would inform the Secretary of the technical committee responsible, the identity of which can be found on the inside front cover. Tel: +44 (0)20 8996 9000. Fax: +44 (0)20 8996 7400.

BSI offers members an individual updating service called PLUS which ensures that subscribers automatically receive the latest editions of standards.

Buying standards

Orders for all BSI, international and foreign standards publications should be addressed to Customer Services. Tel: +44 (0)20 8996 9001. Fax: +44 (0)20 8996 7001. Email: orders@bsi-global.com. Standards are also available from the BSI website at <http://www.bsi-global.com>.

In response to orders for international standards, it is BSI policy to supply the BSI implementation of those that have been published as British Standards, unless otherwise requested.

Information on standards

BSI provides a wide range of information on national, European and international standards through its Library and its Technical Help to Exporters Service. Various BSI electronic information services are also available which give details on all its products and services. Contact the Information Centre. Tel: +44 (0)20 8996 7111. Fax: +44 (0)20 8996 7048. Email: info@bsi-global.com.

Subscribing members of BSI are kept up to date with standards developments and receive substantial discounts on the purchase price of standards. For details of these and other benefits contact Membership Administration. Tel: +44 (0)20 8996 7002. Fax: +44 (0)20 8996 7001. Email: membership@bsi-global.com.

Information regarding online access to British Standards via British Standards Online can be found at <http://www.bsi-global.com/bsonline>.

Further information about BSI is available on the BSI website at <http://www.bsi-global.com>.

Copyright

Copyright subsists in all BSI publications. BSI also holds the copyright, in the UK, of the publications of the international standardization bodies. Except as permitted under the Copyright, Designs and Patents Act 1988 no extract may be reproduced, stored in a retrieval system or transmitted in any form or by any means – electronic, photocopying, recording or otherwise – without prior written permission from BSI.

This does not preclude the free use, in the course of implementing the standard, of necessary details such as symbols, and size, type or grade designations. If these details are to be used for any other purpose than implementation then the prior written permission of BSI must be obtained.

Details and advice can be obtained from the Copyright & Licensing Manager. Tel: +44 (0)20 8996 7070. Fax: +44 (0)20 8996 7553. Email: copyright@bsi-global.com.