

**Flexible sheets  
for waterproofing  
— Reinforced  
bitumen sheets for  
waterproofing of  
concrete bridge decks  
and other trafficked  
areas of concrete  
— Definitions and  
characteristics**

ICS 91.100.50

## National foreword

This British Standard is the UK implementation of EN 14695:2010.

The UK participation in its preparation was entrusted to Technical Committee B/546/9, Bridge deck water proofing.

A list of organizations represented on this committee can be obtained on request to its secretary.

This publication does not purport to include all the necessary provisions of a contract. Users are responsible for its correct application.

**Compliance with a British Standard cannot confer immunity from legal obligations.**

This British Standard was published under the authority of the Standards Policy and Strategy Committee on 31 March 2010

© BSI 2010

ISBN 978 0 580 53869 8

### Amendments/corrigenda issued since publication

| Date | Comments |
|------|----------|
|      |          |
|      |          |
|      |          |
|      |          |

EUROPEAN STANDARD

**EN 14695**

NORME EUROPÉENNE

EUROPÄISCHE NORM

January 2010

ICS 91.100.50

English Version

## Flexible sheets for waterproofing - Reinforced bitumen sheets for waterproofing of concrete bridge decks and other trafficked areas of concrete - Definitions and characteristics

Feuilles souples d'étanchéité - Feuilles bitumineuses  
armées pour l'étanchéité de ponts et autres surfaces en  
béton circulables par les véhicules - Définitions et  
caractéristiques

Abdichtungsbahnen - Bitumenbahnen mit Trägereinlage für  
Abdichtungen von Betonbrücken und andere  
Verkehrsflächen aus Beton - Definitionen und  
Eigenschaften

This European Standard was approved by CEN on 21 November 2009.

CEN members are bound to comply with the CEN/CENELEC Internal Regulations which stipulate the conditions for giving this European Standard the status of a national standard without any alteration. Up-to-date lists and bibliographical references concerning such national standards may be obtained on application to the CEN Management Centre or to any CEN member.

This European Standard exists in three official versions (English, French, German). A version in any other language made by translation under the responsibility of a CEN member into its own language and notified to the CEN Management Centre has the same status as the official versions.

CEN members are the national standards bodies of Austria, Belgium, Bulgaria, Croatia, Cyprus, Czech Republic, Denmark, Estonia, Finland, France, Germany, Greece, Hungary, Iceland, Ireland, Italy, Latvia, Lithuania, Luxembourg, Malta, Netherlands, Norway, Poland, Portugal, Romania, Slovakia, Slovenia, Spain, Sweden, Switzerland and United Kingdom.



EUROPEAN COMMITTEE FOR STANDARDIZATION  
COMITÉ EUROPÉEN DE NORMALISATION  
EUROPÄISCHES KOMITEE FÜR NORMUNG

**Management Centre: Avenue Marnix 17, B-1000 Brussels**

## Contents

Page

|   |           |
|---|-----------|
| Foreword.....   | 4         |
| <b>1 Scope .....</b>  | <b>5</b>  |
| <b>2 Normative references .....</b>   | <b>5</b>  |
| <b>3 Terms and definitions .....</b>  | <b>6</b>  |
| <b>4 Product characteristics .....</b>  | <b>8</b>  |
| 4.1 General.....  | 8         |
| 4.2 Sheet characteristics.....  | 8         |
| 4.2.1 Visible defects.....  | 8         |
| 4.2.2 Dimensions, tolerances and mass per unit area.....  | 8         |
| 4.2.3 Initial amount of mineral surface protection.....   | 9         |
| 4.2.4 Tensile properties.....   | 9         |
| 4.2.5 Water absorption.....   | 9         |
| 4.2.6 Flexibility at low temperature.....   | 9         |
| 4.2.7 Flow resistance at elevated temperature.....  | 9         |
| 4.2.8 Dimensional stability at elevated temperatures.....   | 9         |
| 4.2.9 Thermal ageing behaviour.....   | 9         |
| 4.3 Performance related characteristics.....  | 10        |
| 4.3.1 General.....  | 10        |
| 4.3.2 Bond strength.....  | 10        |
| 4.3.3 Shear strength.....   | 10        |
| 4.3.4 Crack bridging ability.....   | 10        |
| 4.3.5 Compatibility by heat conditioning.....   | 10        |
| 4.3.6 Resistance to compaction of an asphalt layer.....   | 10        |
| 4.3.7 Behaviour of bitumen sheets during application of mastic asphalt.....                                     | 10        |
| 4.3.8 Watertightness.....   | 11        |
| 4.4 Dangerous substances.....   | 11        |
| <b>5 Evaluation of conformity.....</b>  | <b>11</b> |
| 5.1 General.....  | 11        |
| 5.2 Initial type testing (ITT).....   | 11        |
| 5.2.1 General.....  | 11        |
| 5.2.2 Sampling.....   | 11        |
| 5.3 Factory production control (FPC).....   | 12        |
| 5.3.1 General.....  | 12        |
| 5.3.2 Frequency of testing.....   | 12        |
| <b>6 Product data sheet.....</b>  | <b>12</b> |
| <b>7 Marking, labelling and packaging.....</b>  | <b>12</b> |
| <b>Annex A (normative) Initial type testing and frequencies of testing for factory production control .....</b> | <b>14</b> |
| <b>Annex B (normative) Determination of dimensional stability at 160 °C .....</b>                               | <b>16</b> |
| B.1 General.....  | 16        |
| B.2 Procedure.....  | 16        |
| B.3 Precision of test method.....   | 16        |
| B.4 Test report.....  | 16        |
| <b>Annex C (informative) Example of a product data sheet.....</b>   | <b>17</b> |
| <b>Annex D (normative) Determination of the initial amount of mineral surface protection .....</b>              | <b>19</b> |
| D.1 General.....  | 19        |
| D.2 Apparatus and materials.....  | 19        |

|   |   |           |
|---|---|-----------|
| <b>D.3</b>  | <b>Procedure</b> .....                                    | <b>19</b> |
| <b>D.4</b>  | <b>Calculations and expression of results</b> .....       | <b>19</b> |
| <b>D.5</b>  | <b>Precision of the test method</b> .....                 | <b>19</b> |
| <b>D.6</b>  | <b>Test report</b> .....                                  | <b>19</b> |
| <b>Annex ZA (informative) Clauses of this European Standard addressing provisions of the EU</b> |   |           |
|   | <b>Construction Products Directive</b> .....              | <b>20</b> |
| <b>ZA.1</b>   | <b>Scope and relevant characteristics</b> .....           | <b>20</b> |
| <b>ZA.2</b>   | <b>Procedure for attestation of conformity</b> .....      | <b>22</b> |
| <b>ZA.2.1</b>   | <b>System of attestation of conformity</b> .....          | <b>22</b> |
| <b>ZA.2.2</b>   | <b>EC certificate and declaration of conformity</b> ..... | <b>23</b> |
| <b>ZA.3</b>   | <b>CE marking and labelling</b> .....                     | <b>23</b> |
|   | <b>Bibliography</b> .....                                 | <b>27</b> |

## Foreword

This document (EN 14695:2010) has been prepared by Technical Committee CEN/TC 254 “Flexible sheets for waterproofing”, the secretariat of which is held by BSI.

This European Standard shall be given the status of a national standard, either by publication of an identical text or by endorsement, at the latest by July 2010, and conflicting national standards shall be withdrawn at the latest by October 2011.

Attention is drawn to the possibility that some of the elements of this document may be the subject of patent rights. CEN [and/or CENELEC] shall not be held responsible for identifying any or all such patent rights.

This document has been prepared under a mandate given to CEN by the European Commission and the European Free Trade Association, and supports essential requirements of EU Directive(s).

For relationship with EU Directive(s), see informative Annex ZA, which is an integral part of this document.

According to the CEN/CENELEC Internal Regulations, the national standards organizations of the following countries are bound to implement this European Standard: Austria, Belgium, Bulgaria, Croatia, Cyprus, Czech Republic, Denmark, Estonia, Finland, France, Germany, Greece, Hungary, Iceland, Ireland, Italy, Latvia, Lithuania, Luxembourg, Malta, Netherlands, Norway, Poland, Portugal, Romania, Slovakia, Slovenia, Spain, Sweden, Switzerland and the United Kingdom.

## 1 Scope

This European Standard specifies characteristics and performance of reinforced bitumen sheets for waterproofing of concrete bridge decks and other trafficked areas of concrete where the waterproofing system is bonded to the concrete deck and overlaid by asphalt. The standard also specifies the test methods used for verifying the characteristics and performance.

## 2 Normative references

The following referenced documents are indispensable for the application of this document. For dated references, only the edition cited applies. For undated references, the latest edition of the referenced document (including any amendments) applies.

EN 1107-1, *Flexible sheets for waterproofing — Part 1: Bitumen sheets for roof waterproofing — Determination of dimensional stability*

EN 1109, *Flexible sheets for waterproofing — Bitumen sheets for roof waterproofing — Determination of flexibility at low temperature*

EN 1110, *Flexible sheets for waterproofing — Bitumen sheets for roof waterproofing — Determination of flow resistance at elevated temperature*

EN 1296, *Flexible sheets for waterproofing — Bitumen, plastic and rubber sheets for roofing — Method of artificial ageing by long term exposure to elevated temperature*

EN 1848-1, *Flexible sheets for waterproofing — Determination of length, width and straightness — Part 1: Bitumen sheets for roof waterproofing*

EN 1849-1, *Flexible sheets for waterproofing — Determination of thickness and mass per unit area — Part 1: Bitumen sheets for roof waterproofing*

EN 1850-1, *Flexible sheets for waterproofing — Determination of visible defects — Part 1: Bitumen sheets for roof waterproofing*

EN 12039:1999, *Flexible sheets for waterproofing — Bitumen sheets for roof waterproofing — Determination of adhesion of granules*

EN 12311-1, *Flexible sheets for waterproofing — Part 1: Bitumen sheets for roof waterproofing — Determination of tensile properties*

EN 13375:2004, *Flexible sheets for waterproofing — Waterproofing of concrete bridge decks and other concrete surfaces trafficable by vehicles — Specimen preparation*

EN 13416:2001, *Flexible sheets for waterproofing — Bitumen, plastic and rubber sheets for roof waterproofing — Rules for sampling*

EN 13596, *Flexible sheets for waterproofing — Waterproofing of concrete bridge decks and other concrete surfaces trafficable by vehicles — Determination of bond strength*

EN 13653, *Flexible sheets for waterproofing — Waterproofing of concrete bridge decks and other concrete surfaces trafficable by vehicles — Determination of shear strength*

EN 14223, *Flexible sheets for waterproofing — Waterproofing of concrete bridge decks and other concrete surfaces trafficable by vehicles — Determination of water absorption*

EN 14224, *Flexible sheets for waterproofing — Waterproofing of concrete bridge decks and other concrete surfaces trafficable by vehicles — Determination of crack bridging ability*

EN 14691, *Flexible sheets for waterproofing — Waterproofing of concrete bridge decks and other concrete surfaces trafficable by vehicles — Compatibility by heat conditioning*

EN 14692:2005, *Flexible sheets for waterproofing — Waterproofing of concrete bridge decks and other concrete surfaces trafficable by vehicles — Determination of the resistance to compaction of an asphalt layer*

EN 14693, *Flexible sheets for waterproofing — Waterproofing of concrete bridge decks and other concrete surfaces trafficable by vehicles — Determination of the behaviour of bitumen sheets during application of mastic asphalt*

EN 14694, *Flexible sheets for waterproofing — Waterproofing of concrete bridge decks and other concrete surfaces trafficable by vehicles — Determination of resistance to dynamic water pressure after damage by pre-treatment*

EN ISO 9001, *Quality management systems — Requirements (ISO 9001:2008)*

### **3 Terms and definitions**

For the purposes of this document, the terms and definitions given in EN 13375:2004, EN 13416:2001 and the following apply.

#### **3.1 waterproofing**

action to prevent the passage of water from one plane to another

#### **3.2 bridge waterproofing system**

assembly of layers between a concrete bridge deck (or other trafficked areas of concrete) and an overlay

NOTE 1 See Figure 1.

NOTE 2 Generally comprises a primer, the reinforced bitumen sheet (or the assembly of several reinforced bitumen sheets) and the protection layer if specified by the manufacturer.



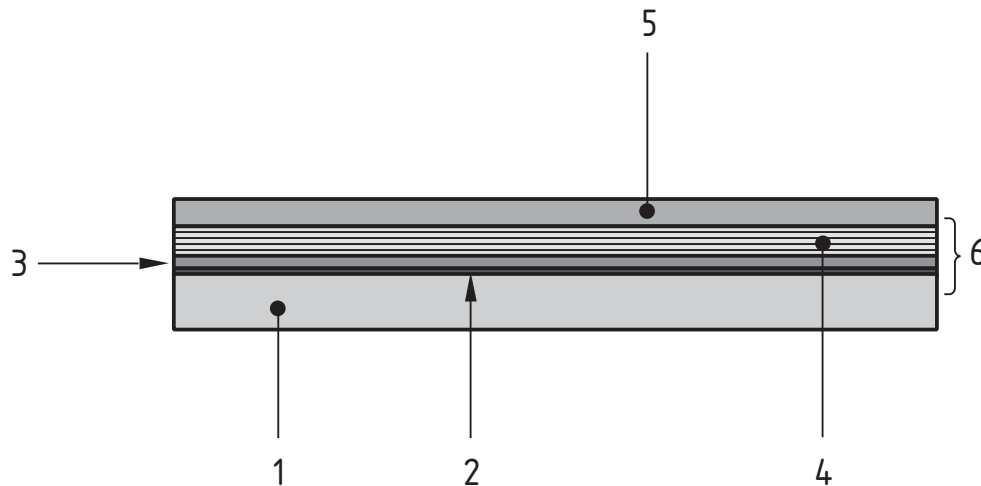

### Key

- 1 concrete bridge deck
- 2 primer
- 3 reinforced bitumen sheet(s)
- 4 protection layer
- 5 overlay
- 6 bridge waterproofing system (2 + 3 and 4 if specified)

**Figure 1 — Schematic section of bridge waterproofing system**

### 3.3

#### **carrier**

material incorporated into or onto a factory-made reinforced bitumen sheet to ensure its stability and/or mechanical resistance

### 3.4

#### **backing**

material incorporated onto a factory-made reinforced bitumen sheet without a permanent mechanical function

### 3.5

#### **surfacing**

material applied on one or both sides of reinforced bitumen sheets, either as a permanent light surface protection on the upper surface or as an anti-sticking substance of the reinforced bitumen sheets

### 3.6

#### **batch**

amount of product manufactured to the same specification within a maximum period of 24 h

### 3.7

#### **manufacturer's limiting value**

#### **MLV**

value stated by the manufacturer to be met during testing

NOTE The MLV can be a minimum or a maximum value according to statements made under product characteristics of this European Standard.

**3.8**  
**manufacturer's declared value**  
**MDV**

value declared by the manufacturer accompanied by a declared tolerance

**3.9**  
**primer**

initial coating applied directly to the prepared concrete deck prior to the bridge waterproofing system being installed to achieve adhesion to the concrete surface

NOTE The primer can be made up by one or more layers of bituminous products or resin based products.

**3.10**  
**reinforced bitumen sheet**

factory made flexible layer of bitumen with internal or external incorporation of one or more carriers, supplied in roll form ready to use

**3.11**  
**protection layer**

first layer above the reinforced bitumen sheet, the aim of which being to protect the sheet from mechanical damage

NOTE Depending on the bridge waterproofing system, this layer can have an additional waterproofing function.

**3.12**  
**overlay**

asphalt layer immediately above the bridge waterproofing system

NOTE Typically, the overlay can be made up of asphalt concrete, sand asphalt or coarse aggregate mastic asphalt.

## **4 Product characteristics**

### **4.1 General**

Where a tolerance is defined by this European Standard it does not have to be declared by the manufacturer.

When tested for purposes other than initial type testing or factory production control (see 5.1), the tests to determine product characteristics indicated in this European Standard shall be started within one month of delivery from the manufacturer.

### **4.2 Sheet characteristics**

#### **4.2.1 Visible defects**

The product shall be free of visible defects, as determined in accordance with EN 1850-1.

#### **4.2.2 Dimensions, tolerances and mass per unit area**

The length, width and straightness shall be determined in accordance with EN 1848-1. The length and width shall not be shorter than the manufacturer's limiting value. The maximum deviation from straightness shall not exceed 20 mm per 10 m length, or in proportion for other lengths (e.g. 10 mm per 5 m length).

Where a product is specified by mass per unit area, it shall be measured in accordance with EN 1849-1, and the results shall lie within the declared tolerance of the manufacturer's declared value.

Where a product is specified by thickness, it shall be measured in accordance with EN 1849-1 and the results shall lie within the declared tolerance of the manufacturer's declared value.

Where sheets with incorporated mineral protection are specified by thickness, the measurement of thickness may additionally be carried out on the granule-free selvedge. This shall be declared in the report.

#### **4.2.3 Initial amount of mineral surface protection**

The initial amount of mineral surface protection shall be determined in accordance with EN 12039:1999, Annex B, except that a 125  $\mu\text{m}$  sieve shall be used. If a distinction is to be made between the different sides of the sheet the initial amount of mineral surface protection shall be determined in accordance with Annex D. The results for the test used shall lie within the declared tolerance of the manufacturer's declared value.

#### **4.2.4 Tensile properties**

The tensile properties shall be determined in accordance with EN 12311-1 and the results (for the longitudinal and transverse directions) shall lie within the declared tolerance of the manufacturer's declared value.

#### **4.2.5 Water absorption**

The content of water absorbed shall be determined in accordance with EN 14223. The water absorption shall be less than or equal to the manufacturer's limiting value.

#### **4.2.6 Flexibility at low temperature**

The flexibility at low temperature shall be determined in accordance with EN 1109. The result shall be less than or equal to the manufacturer's limiting value.

NOTE This test does not give results that directly correspond to the application conditions in practice. Results should only be used to compare products of similar thickness and construction.

#### **4.2.7 Flow resistance at elevated temperature**

The flow resistance at elevated temperature shall be determined in accordance with EN 1110. The result shall be greater than or equal to the manufacturer's limiting value.

#### **4.2.8 Dimensional stability at elevated temperatures**

The dimensional stability at elevated temperature shall be determined in accordance with EN 1107-1 (24 h at 80 °C). The result shall be less than or equal to the manufacturer's limiting value.

For reinforced bitumen sheets to be used with a layer of coarse aggregate mastic asphalt directly on the reinforced bitumen sheet, the dimensional stability at elevated temperatures (1 h at 160 °C) shall be evaluated in accordance with Annex B when subject to regulatory requirements, and may be evaluated when not subject to such requirements. The test result shall be less than or equal to the manufacturer's limiting value.

NOTE The test at 80 °C is intended to determine the dimensional changes as a result of production-induced internal stresses under the effect of heat. When combined with a coarse aggregate mastic asphalt layer, the effect of heat is much larger and can cause severe shrinkage to the reinforced bitumen sheet. This effect is therefore declared as well for sheets intended for use in combination with a coarse aggregate mastic asphalt layer.

#### **4.2.9 Thermal ageing behaviour**

In order to verify the thermal ageing behaviour of the product, characteristics shall be determined before and after exposure in accordance with EN 1296 for a period of 12 weeks. The relevant characteristics are the flexibility at low temperature and the flow resistance at elevated temperature. The flexibility at low temperature shall be determined in accordance with EN 1109 (see 4.2.6) and the results shall be less than or equal to the

manufacturer's limiting value. The flow resistance at elevated temperature shall be determined in accordance with EN 1110 (see 4.2.7) and the results shall lie within the declared tolerance of the manufacturer's declared value.

**NOTE** The purpose of testing in accordance with EN 1296 is to characterize the long-term thermal stability of bitumen. Results should only be used to qualitatively compare products of similar thickness, construction and composition and they cannot be used for general durability classification. The chosen exposure duration for thermal ageing in accordance with EN 1296 has no relevance to real exposure conditions.

### **4.3 Performance related characteristics**

#### **4.3.1 General**

Test specimens for performance-related testing shall be prepared in accordance with EN 13375. Where a sheet can be used in more than one waterproofing system, some of the following tests shall require repeating.

#### **4.3.2 Bond strength**

The bond strength shall be determined in accordance with EN 13596, and shall be greater than or equal to the manufacturer's limiting value.

#### **4.3.3 Shear strength**

The shear strength shall be determined in accordance with EN 13653, and shall be greater than or equal to the manufacturer's limiting value.

#### **4.3.4 Crack bridging ability**

Where required the crack bridging ability of fully bonded reinforced bitumen sheets shall be determined in accordance with EN 14224 and the temperature shall be lower than or equal to the manufacturer's limiting value. Testing on type 3 specimens covers also type 1 specimens.

The crack bridging ability shall be evaluated when subject to regulatory requirements, and may be evaluated when not subject to such requirements.

#### **4.3.5 Compatibility by heat conditioning**

The compatibility by heat conditioning shall be determined in accordance with EN 14691. The test result shall be greater than or equal to the manufacturer's limiting value.

#### **4.3.6 Resistance to compaction of an asphalt layer**

For reinforced bitumen sheets to be used with a compacted asphalt layer directly on the reinforced bitumen sheet, the resistance of the reinforced bitumen sheet to compaction of an asphalt layer shall be determined in accordance with EN 14692:2005, method 1 or method 2, and a resistant result is required to demonstrate product compliance with this European Standard.

#### **4.3.7 Behaviour of bitumen sheets during application of mastic asphalt**

Only a bitumen sheet intended for use with a protection layer of coarse aggregate mastic asphalt shall be tested to determine its behaviour during application of mastic asphalt in accordance with EN 14693. The test results shall be less than or equal to the manufacturer's limiting value.

#### 4.3.8 Watertightness

The watertightness of the reinforced bitumen sheet (or double sheet system) shall be determined in accordance with EN 14694 without pretreatment and shall give a pass result.

#### 4.4 Dangerous substances

For products placed on the market within the European Economic Area, see ZA.1. Outside the EEA products shall conform to any applicable provisions related to dangerous substances valid in the place of use.

Bitumen sheets covered by this standard shall not contain asbestos or coal tar constituents. The manufacturer shall disclose on the product wrapper and in the health and safety data sheets the use of any additive or constituent regulated as hazardous in the country of intended use.

NOTE See also Bibliography [3] and [4].

### 5 Evaluation of conformity

#### 5.1 General

The compliance of the product with the requirements of this European Standard and with the stated values shall be demonstrated by:

- initial type testing;
- factory production control by the manufacturer, including product assessment.

For the purposes of testing, the product may be grouped into families, where it is considered that the results from any one product within the family, for the selected property, are representative for all products within that family.

#### 5.2 Initial type testing (ITT)

##### 5.2.1 General

Initial type testing shall be performed to show conformity with this European Standard. Tests previously performed in accordance with the provisions of this European Standard (same product, same characteristic(s), test method, sampling procedure, system of attestation of conformity, etc.) may be taken into account. In addition, initial type testing shall be performed at the beginning of the production of a new product type (unless a member of the same family) or at the beginning of a new method of production (where this may affect the stated properties).

All characteristics in Clause 4 shall be subject to initial type testing, where relevant.

Whenever a change occurs in the product design, the raw material or supplier of the components, or the production process (subject to the definition of a family), which would change significantly one or more of the characteristics, the type tests shall be repeated for the appropriate characteristic(s).

##### 5.2.2 Sampling

Samples shall be taken according to EN 13416 and specimens shall be prepared according to EN 13375.

### **5.3 Factory production control (FPC)**

#### **5.3.1 General**

The manufacturer shall establish, document and maintain an FPC system to ensure that the products placed on the market conform to the stated performance characteristics. The FPC system shall consist of procedures, regular inspections and tests and/or assessments, and the use of the results to control raw and other incoming materials or components, equipment, the production process and the product.

An FPC system conforming with the requirements of EN ISO 9001, and made specific to the requirements of this European Standard, shall be considered to satisfy these requirements.

The results of inspections, tests or assessments requiring action shall be recorded, as shall any action taken. The action to be taken when control values or criteria are not met shall be recorded.

#### **5.3.2 Frequency of testing**

Minimum frequencies of testing for factory production control shall be as Table A.1.

## **6 Product data sheet**

The characteristics of the product, determined in accordance with the test methods specified in this European Standard, shall be listed in a technical data sheet. The technical data sheet shall also give the following information:

- a) product trade name and manufacturer's name;
- b) origin/source of manufacture or traceable code;
- c) description of the product, e.g. type and number of carriers, type of coating, mass or thickness, type of surfacing;
- d) primer used and amount;
- e) type of protection layer;
- f) method of application;
- g) characteristics according to 4.2 and 4.3;
- h) certification mark, if any;
- i) consumer information, e.g. restrictions concerning use and storage and safety precautions during installation and disposal.

NOTE An example of a product data sheet is shown in Annex C.

## **7 Marking, labelling and packaging**

The following information shall be indicated on each roll:

- a) production date or identification number;
- b) product trade name;

- c) length and width;
- d) thickness or mass per unit area;
- e) labelling according to national regulations related to dangerous substances and/or health and safety.

Where ZA.3 covers the same information as required by this clause, the requirements of this clause are met.

## **Annex A** (normative)

### **Initial type testing and frequencies of testing for factory production control**

The minimum frequencies of testing for factory production control shall be as Table A.1.



**Table A.1 — Initial type testing and frequencies of factory production control**

| Product characteristic   | Subclause | Initial type testing | Minimum frequencies of testing per |                |                |                |
|--|-----------|----------------------|------------------------------------|----------------|----------------|----------------|
|  |           |                      | Batch                              | Week           | Month          | Year           |
| Visible defects  | 4.2.1     | X                    | 1                                  |                |                |                |
| Length and width   | 4.2.2     | X                    | 1                                  |                |                |                |
| Straightness   | 4.2.2     | X                    |                                    | 1              |                |                |
| Mass per unit area or thickness                                  | 4.2.2     | X                    | 1                                  |                |                |                |
| Initial amount of mineral surface protection                     | 4.2.3     | X                    |                                    |                |                | 1              |
| Tensile properties   | 4.2.4     | X                    |                                    |                | 1 <sup>a</sup> |                |
| Water absorption   | 4.2.5     | X                    |                                    |                |                | 1              |
| Flexibility at low temperature                                   | 4.2.6     | X                    |                                    | 1              |                |                |
| Flow resistance at elevated temperature                          | 4.2.7     | X                    |                                    | 1 <sup>b</sup> |                |                |
| Dimensional stability  | 4.2.8     | X                    |                                    |                |                | 2 <sup>a</sup> |
| Thermal ageing behaviour   | 4.2.9     | X                    |                                    |                |                | 1 <sup>c</sup> |
| Bond strength  | 4.3.2     | X                    |                                    |                |                | 1 <sup>d</sup> |
| Shear strength   | 4.3.3     | X                    |                                    |                |                |                |
| Crack bridging ability   | 4.3.4     | X <sup>e</sup>       |                                    |                |                |                |
| Compatibility by heat conditioning                               | 4.3.5     | X                    |                                    |                |                |                |
| Resistance to compaction of an asphalt layer                     | 4.3.6     | X                    |                                    |                |                |                |
| Behaviour of bitumen sheets during application of mastic asphalt | 4.3.7     | X                    |                                    |                |                |                |
| Watertightness   | 4.3.8     | X                    |                                    |                |                |                |

<sup>a</sup> In the case where a manufacturer is continuously producing numerous different sheets which contain the same carrier (type and mass) and the same type of coating, the frequency of these tests which relate essentially to the carrier, may be considered on the total number of these different sheets.

<sup>b</sup> In the case where a manufacturer is continuously producing numerous differently reinforced sheets, and/or sheets which differ only by the presence of incorporated protection, whilst using the same type of coating and having a similar thickness, the frequency for these tests, which relate essentially to the type of coating, may be considered on the total number of these different sheets.

<sup>c</sup> Control of the product is required, either by direct testing or by indirect control.

<sup>d</sup> Bond strength is tested in combination with the primer used in ITT, only on test specimen type 1. In the case where the manufacturer is continuously producing and/or testing the primer containing the same components, FPC on the primer may be considered as an alternative of bond strength.

<sup>e</sup> Where required.

## Annex B (normative)

### Determination of dimensional stability at 160 °C

#### B.1 General

This annex specifies how to determine the dimensional stability at 160 °C of reinforced bitumen sheets for waterproofing of concrete bridge decks and other areas of concrete trafficable by vehicles, simulating the effect of applying mastic asphalt on the sheet.

The test is performed in connection with testing according to EN 1107-1.

#### B.2 Procedure

Follow the procedure given in EN 1107-1, with the following additions:

- a) Preheat the oven to a temperature of  $(160 \pm 2)$  °C;
- b) Place the specimens in the preheated oven for  $(60 \pm 4)$  min.

#### B.3 Precision of test method

Precision data are not available.

#### B.4 Test report

The test report shall be in accordance with EN 1107-1, with the following additions:

- a) A reference to this European Standard, EN 14695:2009, Annex B.
- b) The test results at 160 °C.

## Annex C (informative)

### Example of a product data sheet

A product data sheet should include the following:

- date and reference of this technical data sheet;
- product trade name;
- manufacturer/supplier;
- origin/source of manufacturing;
- description of the product (e.g. type and number of carriers, type of coating, mass or thickness, type of surfacing);
- primer and amount for the application;
- type of protection layer;
- type of overlay for the application;
- intended use and method of application;
- product performance<sup>1)</sup> (see Table C.1);
- certification mark where relevant;
- consumer information<sup>2)</sup>.

**Table C.1 — Information from testing**

| Characteristic     | Test method | Unit              | Expression of result <sup>a</sup> | Value or statement <sup>b</sup> |
|--------------------|-------------|-------------------|-----------------------------------|---------------------------------|
| Visible defects    | EN 1850-1   | —                 | Visible defects                   |                                 |
| Length             | EN 1848-1   | m                 | MLV                               |                                 |
| Width              | EN 1848-1   | m                 | MLV                               |                                 |
| Straightness       | EN 1848-1   | —                 | Pass                              |                                 |
| Mass per unit area | EN 1849-1   | kg/m <sup>2</sup> | MDV                               |                                 |
| Thickness          | EN 1849-1   | mm                | MDV                               |                                 |

1) See ZA.3 which limits the information to be given in association with CE marking.

2) For example, restrictions concerning use and storage and safety precaution during installation and disposal.

Table C.1 (continued)

| Characteristic   | Test method                                    | Unit                    | Expression of result <sup>a</sup> | Value or statement <sup>b</sup> |
|--|--|-------------------------|-----------------------------------|---------------------------------|
| Initial amount of mineral surface protection   | EN 12039:1999 Annex B                          | g/m <sup>2</sup>        | MDV                               |                                 |
| Tensile properties: maximum tensile force  | EN 12311-1                                     | N/50 mm                 | MDV                               |                                 |
| Tensile properties: elongation   | EN 12311-1                                     | %                       | MDV                               |                                 |
| Water absorption   | EN 14223                                       | %                       | MLV                               | —                               |
| Flexibility at low temperature   | EN 1109  | °C                      | MLV                               |                                 |
| Flow resistance at elevated temperature  | EN 1110  | °C                      | MLV                               |                                 |
| Dimensional stability  | EN 1107-1 or Annex B of this European Standard | %                       | MLV                               |                                 |
| Thermal ageing by long term exposure to elevated temperature   | EN 1296  | See EN 1109 and EN 1110 | MDV                               |                                 |
| Bond strength  | EN 13596                                       | N/mm <sup>2</sup>       | MLV                               |                                 |
| Shear strength   | EN 13653                                       | N/mm <sup>2</sup>       | MLV                               |                                 |
| Crack bridging ability   | EN 14224                                       | °C                      | MLV                               | —                               |
| Compatibility by heat conditioning   | EN 14691                                       | %                       | MLV                               |                                 |
| Resistance to compaction of an asphalt layer   | EN 14692                                       | -                       | Pass                              | —                               |
| Behaviour of bitumen sheets during application of mastic asphalt   | EN 14693                                       | %<br>mm<br>-            | MLV<br>MLV<br>MLV                 | —<br>—                          |
| Watertightness   | EN 14694                                       | —                       | Pass                              | —                               |
| <b>Key</b>   |  |                         |                                   |                                 |
| — Not relevant.  |  |                         |                                   |                                 |
| <sup>a</sup> MLV: manufacturer's limiting value according to 3.7; MDV: manufacturer's declared value according to 3.8. |  |                         |                                   |                                 |
| <sup>b</sup> To be completed by the manufacturer.  |  |                         |                                   |                                 |

## Annex D (normative)

### Determination of the initial amount of mineral surface protection

#### D.1 General

This annex specifies how to determine the initial amount of mineral surface protection of grain size mainly larger than 0,125 mm, for reinforced bitumen sheets in the waterproofing system, since there is a risk that too much surface protection could introduce a sliding layer between the sheet and the layer above.

This test is performed according to EN 12039:1999, Annex B with some specified changes.

#### D.2 Apparatus and materials

According to EN 12039:1999, Annex B with the following changes or additions:

D.2.1 Sieve, with a mesh width of 0,125 mm.

D.2.2 Spatula/knife, heat resistant.

#### D.3 Procedure

Follow the procedure given in EN 12039:1999, Annex B, with the following addition:

After determination of the area of the test specimens, remove the coating layer with the surface protection down to the reinforcement on each of the test specimens using a heated spatula or knife. Place the coating layer with the surface protection from each test specimen in the extractor.

The dried material shall be sieved on the sieve (D.2.1) and the mass of granules on the sieve (D.2.1) shall be weighed to the nearest 0,01 g ( $N_i$ ). The procedure shall be repeated on each specimen.

#### D.4 Calculations and expression of results

Calculation and expression of individual results shall be made according to EN 12039:1999, Annex B.

Calculate the mean ( $G_0$ ), expressed in grams per square metre ( $g/m^2$ ), of the six test specimens.

#### D.5 Precision of the test method

Precision data are not available.

The results are affected by an inaccuracy, as part of the surface protection can contain material with a grain size  $< 0,125$  mm and the coating layer can contain filler with a grain size  $> 0,125$  mm.

#### D.6 Test report

The test report shall be in accordance with EN 12039, with the following additions:

- a) A reference to this European Standard, EN 14695:2010, Annex D;
- b) The test results in accordance with EN 12039:1999, Annex B and this annex.

## Annex ZA (informative)

### Clauses of this European Standard addressing provisions of the EU Construction Products Directive

#### ZA.1 Scope and relevant characteristics

This European Standard has been prepared under Mandate M/124 Road construction products (as amended) given to CEN by the European Commission and the European Free Trade Association.

The clauses of this European Standard shown in this annex meet the requirements of the mandate given under the EU Construction Products Directive (89/106/EEC).

Compliance with these clauses confers a presumption of fitness of the bitumen sheets covered by this annex for the intended uses indicated herein; reference shall be made to the information accompanying the CE marking.

**WARNING — Other requirements and other EU Directives, not affecting the fitness for intended uses, can be applicable to the bitumen sheets falling within the scope of this European Standard.**

NOTE 1 In addition to any specific clauses relating to dangerous substances contained in this standard, there may be other requirements applicable to the products falling within its scope (e.g. transposed European legislation and national laws, regulations and administrative provisions). In order to meet the provisions of the EU Construction Products Directive, these requirements need also to be complied with, when and where they apply.

NOTE 2 An informative database of European and national provisions on dangerous substances is available on the European Commission website on EUROPA, accessed through [http://ec.europa.eu/enterprise/construction/internal/dangsub/dangmain\\_en.htm](http://ec.europa.eu/enterprise/construction/internal/dangsub/dangmain_en.htm).

This annex establishes the conditions for the CE marking of the reinforced bitumen sheets intended for the uses indicated in Table ZA.1 and shows the relevant clauses applicable.

This annex has the same scope as Clause 1 of this standard and is defined by Table ZA.1

**Table ZA.1 — Relevant clauses for reinforced bitumen sheets for waterproofing of concrete bridge decks and other trafficked areas of concrete**

| <b>Product:</b> reinforced bitumen sheets as covered under the scope of this standard                  |  |                              |                   |
|--|--|------------------------------|-------------------|
| <b>Intended use:</b> for waterproofing of concrete bridge decks and other trafficked areas of concrete |  |                              |                   |
| <b>Essential characteristics</b>   | <b>Requirement clauses in this European Standard</b> | <b>Levels and/or classes</b> | <b>Notes</b>      |
| Watertightness   | 4.3.8  | —                            | PASS              |
|  | 4.2.5  | —                            | MLV               |
| Tensile strength   | 4.2.4  | —                            | MDV               |
| Bond strength  | 4.3.2  | —                            | MLV               |
| Capacity to bridge cracks  | 4.3.4  | —                            | MLV               |
| Compatibility  | 4.3.5  | —                            | MLV               |
| Cold bending behaviour   | 4.2.6  | —                            | MLV               |
| Resistance to shear  | 4.3.3  | —                            | MLV               |
| Resistance to heat impact  | 4.3.7  | —                            | MLV               |
| Resistance to perforation (compaction)   | 4.3.6  | —                            | PASS              |
| Durability   | 4.2.5, 4.2.9, 4.3.5                                  | —                            | MLV, MDV, MLV     |
| Dangerous substances   | 4.4  | —                            | See notes in ZA.1 |
| <b>Key</b>   |  |                              |                   |
| — No classes or levels are given by the mandate.   |  |                              |                   |

The requirement on a certain characteristic is not applicable in those Member States (MSs) where there are no regulatory requirements on that characteristic for the intended use of the product. In this case, manufacturers placing their products on the market of these Member States are not obliged either to determine or to declare the performance of their products with regard to this characteristic, and the option "No performance determined" (NPD) in the information accompanying the CE marking (see ZA.3) may be used.

The "No performance determined" (NPD) option may not be used where the characteristic is subject to a threshold level. Otherwise the NPD option may be used when and where the characteristic, for a given intended use, is not subject to regulatory requirements.

NOTE 3 Watertightness and compatibility are characteristics in their own right, but they also have an influence on durability. However, the tests for these two characteristics need be made only once.

## ZA.2 Procedure for attestation of conformity

### ZA.2.1 System of attestation of conformity

The system of attestation of conformity of reinforced bitumen sheets indicated in Table ZA.1, in accordance with the Decision of the Commission 98/601/EC of 13 October 1998 as amended by 01/596/EC and as given in Annex III of Mandate M/124 for Road Construction Products, is shown in Table ZA.2 for the indicated intended use and relevant classes.

**Table ZA.2 — System of attestation of conformity**

| Product  | Intended use   | Level(s) or class(es) | Attestation of conformity system |
|--|--|-----------------------|----------------------------------|
| Reinforced bitumen sheets  | On concrete bridge decks and other concrete surfaces trafficable by vehicles | None                  | 2+                               |
| <p>NOTE For information on conformity to system 2+, see Directive 89/106/EEC (CPD), Annex III.2.(ii), <i>First Possibility</i>, including certification of the factory production control by an approved body on the basis of initial inspection of the factory and the factory production control as well as of continuous surveillance, assessment and approval of factory production control.</p> |  |                       |                                  |

The attestation of conformity of the bitumen sheets in Table ZA.1 shall be based on the evaluation of conformity procedures indicated in Table ZA.3 resulting from the application of the clauses of this European Standard indicated therein.

**Table ZA.3 — Assignment of evaluation of conformity tasks for bitumen sheets under system 2+**

| Tasks  |  | Content of the task                                     | Evaluation of conformity clauses to apply |
|--|--|---|---|
| Tasks under the responsibility of the manufacturer | Factory production control (FPC)               | Parameters related to all characteristics of Table ZA.1 | 5.3                                       |
|  | Initial type testing (ITT) by the manufacturer | All characteristics of Table ZA.1                       | 5.2                                       |
|  | Testing of samples taken at the factory        | All characteristics of Table ZA.1                       | 5.3                                       |
| Task for the notified body                         | Certification of FPC on the basis of           | Initial inspection of factory and of FPC                | 5.3                                       |
|  |  | Continuous surveillance, assessment and approval of FPC | 5.3                                       |



### ZA.2.2 EC certificate and declaration of conformity

When compliance with the conditions of this annex is achieved, and once the notified body has drawn up the certificate specified as follows, the manufacturer or his agent established in the EEA shall prepare and retain a declaration of conformity, which entitles the manufacturer to affix the CE marking. This declaration shall include:

- name and address of the manufacturer, or his authorized representative established in the EEA, and the place of production;

NOTE 1 The manufacturer may also be the person responsible for placing the product onto the EEA market, if he takes responsibility for CE marking.

- description of the product (type, identification, use), and a copy of the information accompanying the CE marking;

NOTE 2 Where some of the information required for the Declaration is already given in the CE marking information, it does not need to be repeated.

- provisions to which the product conforms (i.e. Annex ZA of this European Standard);
- particular conditions applicable to the use of the product (e.g. provisions for use under certain conditions);
- the number of the accompanying factory production control certificate;
- name of, and position held by, the person empowered to sign the declaration on behalf of the manufacturer or his authorized representative.

The declaration shall be accompanied by a factory production control certificate, drawn up by the notified body, which shall contain, in addition to the information above, the following:

- name and address of the notified body;
- the number of the factory production control certificate;
- conditions and period of validity of the certificate, where applicable;
- name of, and position held by, the person empowered to sign the certificate.

The declaration of conformity and the EC certificate shall be presented in the language or languages accepted in the Member State in which the product is to be used.

### ZA.3 CE marking and labelling

The manufacturer or his authorized representative established within the EEA is responsible for the affixing of the CE marking. The CE marking symbol to affix shall be in accordance with Directive 93/68/EEC. The CE marking symbol, the number of the EC certificate of factory production control and the information required by Clause 7 (except Clause 7, a)) shall be shown on a label attached to the product.

The CE marking symbol shall also appear on the accompanying technical documentation, together with the following:

- identification number of the certification body;
- name or identifying mark and registered address of the producer;
- the last two digits of the year in which the marking is affixed;

- the number of the EC Certificate of factory production control, the last two digits of the year in which the marking was affixed;
- reference to this European Standard (EN 14695);
- description of the product: the information required by Clause 7 (except Clause 7, a)), type of carrier, type of coatings;
- type of surfacing, and the intended method of installation;
- information on the relevant characteristic values in Table ZA.1.

The "No performance determined" (NPD) option may not be used where the characteristic is subject to a threshold level. Otherwise, the NPD option may be used when and where the characteristic, for a given intended use, is not subject to regulatory requirements.

Figure ZA.1 gives an example of the information to be given on the accompanying commercial (technical) documentation.

|   |
|---|
| <br>01234  |
| <b>AnyCo Ltd, PO Box 21, B-1050</b><br><br><b>10</b><br><br>01234-CPD-00234   |
| <p style="text-align: center;"><b>EN 14695</b></p> <p>1 m × 10 m × 5 mm, polyester non-woven, elastomeric modified bitumen, fine mineral and polymeric sheeting, torchable only. For single layer application with protection layer of asphalt concrete. Primer used in tests: primer XYZ...(trade name)</p> <p>Tensile strength in longitudinal direction:<br/>         900 N/50 mm ± 50 N/50 mm<br/>         Tensile strength in transverse direction:<br/>         850 N/50 mm ± 50 N/50 mm<br/>         Elongation in both direction: (45 ± 4) %<br/>         Cold bending: ≤ - 20 °C<br/>         Watertightness: Pass<br/>         Water absorption: ≤ 0,5 %<br/>         Bond strength:<br/>         - to concrete: ≥ 1,0 N/mm<sup>2</sup><br/>         - to asphalt concrete: ≥ 0,5 N/mm<sup>2</sup><br/>         - to mastic asphalt: ≥ 0,8 N/mm<sup>2</sup><br/>         Capacity to bridge cracks: type 3 - pass at - 20 °C<br/>         Resistance to shear:<br/>         - asphalt concrete: ≥ 0,2 N/mm<sup>2</sup><br/>         - mastic asphalt: ≥ 0,3 N/mm<sup>2</sup><br/>         Compatibility: 5 %<br/>         Resistance to heat impact: NPD<br/>         Resistance to perforation: Pass<br/>         Durability:<br/>         - water absorption: ≤ 0,5 %<br/>         - thermal ageing behaviour (- 15 ± 5) °C/ ≥ 100 °C<br/>         - compatibility: 5 %</p> |

CE conformity marking, consisting of the “CE”-symbol given in Directive 93/68/EEC

Identification number of the certification body

Name or identifying mark and registered address of the producer

Last two digits of the year in which the marking was affixed

Certificate number

No. of European Standard

Description of product

and

information on regulated characteristics

**Figure ZA.1 — Example of CE marking information to be given on the accompanying commercial (technical) documentation for a product**

In addition to any specific information relating to dangerous substances shown above, the product should also be accompanied, when and where required and in the appropriate form, by documentation listing any other legislation on dangerous substances for which compliance is claimed, together with any information required by that legislation.

NOTE 1 European legislation without national derogations need not be mentioned.

NOTE 2 Affixing the CE marking symbol means, if a product is subject to more than one directive that it complies with all applicable directives.

## Bibliography

- [1] Guidance paper F "Durability and the Construction Products Directive"
- [2] Guidance paper D "CE marking under the Construction Products Directive"
- [3] Guidance paper H "A harmonized approach to dangerous substances under the Construction Products Directive"
- [4] Essential Requirements (ER) n° 3 "Hygiene, health and environmental protection" of the Council Directive of 21 December 1988 on the approximation of laws, regulations and administrative provisions of the Member States relating to constructions products (89/106/EEC)
- [5] EN 13707, *Flexible sheets for waterproofing — Reinforced bitumen sheets for roof waterproofing — Definitions and characteristics*

---

## BSI - British Standards Institution

BSI is the independent national body responsible for preparing British Standards. It presents the UK view on standards in Europe and at the international level. It is incorporated by Royal Charter.

### Revisions

British Standards are updated by amendment or revision. Users of British Standards should make sure that they possess the latest amendments or editions.

It is the constant aim of BSI to improve the quality of our products and services. We would be grateful if anyone finding an inaccuracy or ambiguity while using this British Standard would inform the Secretary of the technical committee responsible, the identity of which can be found on the inside front cover. Tel: +44 (0)20 8996 9000. Fax: +44 (0)20 8996 7400.

BSI offers members an individual updating service called PLUS which ensures that subscribers automatically receive the latest editions of standards.

### Buying standards

Orders for all BSI, international and foreign standards publications should be addressed to Customer Services. Tel: +44 (0)20 8996 9001. Fax: +44 (0)20 8996 7001 Email: [orders@bsigroup.com](mailto:orders@bsigroup.com) You may also buy directly using a debit/credit card from the BSI Shop on the Website <http://www.bsigroup.com/shop>

In response to orders for international standards, it is BSI policy to supply the BSI implementation of those that have been published as British Standards, unless otherwise requested.

### Information on standards

BSI provides a wide range of information on national, European and international standards through its Library and its Technical Help to Exporters Service. Various BSI electronic information services are also available which give details on all its products and services. Contact Information Centre. Tel: +44 (0)20 8996 7111 Fax: +44 (0)20 8996 7048 Email: [info@bsigroup.com](mailto:info@bsigroup.com)

Subscribing members of BSI are kept up to date with standards developments and receive substantial discounts on the purchase price of standards. For details of these and other benefits contact Membership Administration. Tel: +44 (0)20 8996 7002 Fax: +44 (0)20 8996 7001 Email: [membership@bsigroup.com](mailto:membership@bsigroup.com)

Information regarding online access to British Standards via British Standards Online can be found at <http://www.bsigroup.com/BSOL>

Further information about BSI is available on the BSI website at <http://www.bsigroup.com>.

### Copyright

Copyright subsists in all BSI publications. BSI also holds the copyright, in the UK, of the publications of the international standardization bodies. Except as permitted under the Copyright, Designs and Patents Act 1988 no extract may be reproduced, stored in a retrieval system or transmitted in any form or by any means – electronic, photocopying, recording or otherwise – without prior written permission from BSI.

This does not preclude the free use, in the course of implementing the standard, of necessary details such as symbols, and size, type or grade designations. If these details are to be used for any other purpose than implementation then the prior written permission of BSI must be obtained.

Details and advice can be obtained from the Copyright and Licensing Manager. Tel: +44 (0)20 8996 7070 Email: [copyright@bsigroup.com](mailto:copyright@bsigroup.com)