

# Test method for metallic fibre concrete — Measuring the flexural tensile strength (limit of proportionality (LOP), residual)

ICS 91.100.30

## National foreword

This British Standard is the UK implementation of EN 14651:2005+A1:2007. It supersedes BS EN 14651:2005 which is withdrawn.

The start and finish of text introduced or altered by amendment is indicated in the text by tags. Tags indicating changes to CEN text carry the number of the CEN amendment. For example, text altered by CEN amendment A1 is indicated by  $\square_{A1}$   $\langle A1 \rangle$ .

The UK participation in its preparation was entrusted to Technical Committee B/524, Precast concrete products.

A list of organizations represented on this committee can be obtained on request to its secretary.

This publication does not purport to include all the necessary provisions of a contract. Users are responsible for its correct application.

**Compliance with a British Standard cannot confer immunity from legal obligations.**

This British Standard was published under the authority of the Standards Policy and Strategy Committee on 11 July 2005

© BSI 2008

ISBN 978 0 580 61052 3

### Amendments/corrigenda issued since publication

Date	Comments
31 March 2008	Implementation of CEN amendment A1:2007

English Version

## Test method for metallic fibre concrete - Measuring the flexural tensile strength (limit of proportionality (LOP), residual)

Méthode d'essai du béton de fibres métalliques - Mesurage de la résistance à la traction par flexion (limite de proportionnalité (LOP), résistance résiduelle)

Prüfverfahren für Beton mit metallischen Fasern - Bestimmung der Biegezugfestigkeit (Proportionalitätsgrenze, residuelle Biegezugfestigkeit)

This European Standard was approved by CEN on 3 April 2005 and includes Amendment 1 approved by CEN on 16 August 2007.

CEN members are bound to comply with the CEN/CENELEC Internal Regulations which stipulate the conditions for giving this European Standard the status of a national standard without any alteration. Up-to-date lists and bibliographical references concerning such national standards may be obtained on application to the CEN Management Centre or to any CEN member.

This European Standard exists in three official versions (English, French, German). A version in any other language made by translation under the responsibility of a CEN member into its own language and notified to the CEN Management Centre has the same status as the official versions.

CEN members are the national standards bodies of Austria, Belgium, Bulgaria, Cyprus, Czech Republic, Denmark, Estonia, Finland, France, Germany, Greece, Hungary, Iceland, Ireland, Italy, Latvia, Lithuania, Luxembourg, Malta, Netherlands, Norway, Poland, Portugal, Romania, Slovakia, Slovenia, Spain, Sweden, Switzerland and United Kingdom.



EUROPEAN COMMITTEE FOR STANDARDIZATION  
COMITÉ EUROPÉEN DE NORMALISATION  
EUROPÄISCHES KOMITEE FÜR NORMUNG

Management Centre: rue de Stassart, 36 B-1050 Brussels

## Contents

page

Foreword.....	3
<b>1 Scope .....</b>	<b>4</b>
<b>2 Normative references .....</b>	<b>4</b>
<b>3 Terms and definitions .....</b>	<b>4</b>
<b>4 Symbols and abbreviated terms .....</b>	<b>5</b>
4.1 Symbols .....	5
4.2 Abbreviations .....	5
<b>5 Principle.....</b>	<b>6</b>
<b>6 Apparatus .....</b>	<b>6</b>
<b>7 Test specimens .....</b>	<b>7</b>
7.1 Shape and size of test specimens .....	7
7.2 Manufacture and curing of test specimens .....	7
7.3 Notching of test specimens .....	7
<b>8 Testing procedure.....</b>	<b>8</b>
8.1 Preparation and positioning of test specimens .....	8
8.2 Bending test .....	10
<b>9 Expression of results .....</b>	<b>11</b>
9.1 Equivalence between CMOD and deflection .....	11
9.2 Limit of proportionality .....	12
9.3 Residual flexural tensile strength .....	13
<b>10 Test report .....</b>	<b>14</b>
<b>11 Precision .....</b>	<b>15</b>
<b>Annex A (informative) Expressions for limit of proportionality and for residual flexural tensile strength.....</b>	<b>16</b>

## Foreword

This document (EN 14651:2005+A1:2007) has been prepared by Technical Committee CEN/TC 229 “Precast concrete products”, the secretariat of which is held by AFNOR.

This document shall be given the status of a national standard, either by publication of an identical text or by endorsement, at the latest by March 2008 and conflicting national standards shall be withdrawn at the latest by March 2008.

This document includes Amendment 1, approved by CEN on 2007-08-16.

This document supersedes EN 14651:2005.

The start and finish of text introduced or altered by amendment is indicated in the text by tags A1 and A1.

This standard is one of a series concerned with testing metallic fibered concrete.

According to the CEN/CENELEC Internal Regulations, the national standards organizations of the following countries are bound to implement this European Standard: Austria, Belgium, Bulgaria, Cyprus, Czech Republic, Denmark, Estonia, Finland, France, Germany, Greece, Hungary, Iceland, Ireland, Italy, Latvia, Lithuania, Luxembourg, Malta, Netherlands, Norway, Poland, Portugal, Romania, Slovakia, Slovenia, Spain, Sweden, Switzerland and United Kingdom.

## 1 Scope

This European Standard specifies a method of measuring the flexural tensile strength of metallic fibered concrete on moulded test specimen. The method provides for the determination of the limit of proportionality (*LOP*) and of a set of residual flexural tensile strength values.

This testing method is intended for metallic fibres no longer than 60 mm. The method can also be used for a combination of metallic fibres and, a combination of metallic fibres with other fibres.

## 2 Normative references

The following referenced documents are indispensable for the application of this document. For dated references, only the edition cited applies. For undated references, the latest edition of the referenced document (including any amendments) applies.

EN 12350-1, *Testing fresh concrete – Part 1: Sampling*.

EN 12390-1, *Testing hardened concrete – Part 1: Shape, dimensions and other requirements for specimens and moulds*.

EN 12390-2, *Testing hardened concrete – Part 2: Making and curing specimens for strength tests*.

EN 12390-4, *Testing hardened concrete – Part 4: Compressive strength – Specification for testing machines*.

## 3 Terms and definitions

For the purposes of this document, the following terms and definitions apply.

**3.1 crack mouth opening displacement**  
linear displacement measured by a transducer installed as specified in 7.1 and illustrated in Figure 4, on a prism subjected to a centre-point load  $F$

**3.2 deflection**  
linear displacement measured by a transducer installed as specified in 7.1 and illustrated in Figure 5, on a prism subjected to a centre-point load  $F$

**3.3 limit of proportionality**  
stress at the tip of the notch which is assumed to act in an uncracked mid-span section, with linear stress distribution, of a prism subjected to the centre-point load  $F_L$  defined in 8.2

**3.4 residual flexural tensile strength**  
fictitious stress at the tip of the notch which is assumed to act in an uncracked mid-span section, with linear stress distribution, of a prism subjected to the centre-point load  $F_j$  corresponding to  $CMOD_j$  where  $CMOD_j > CMOD_{F_L}$  or to  $\delta_j$  where  $\delta_j > \delta_{F_L}$  ( $j = 1,2,3,4$ )

## 4 Symbols and abbreviated terms

### 4.1 Symbols

$CMOD_{FL}$	$CMOD$ at $LOP$
$CMOD_j$	value of $CMOD$ , $j = 1, 2, 3$ or $4$
$F$	load
$F_j$	load value, $j = 1, 2, 3$ or $4$
$F_L$	load at $LOP$
$L$	length of test specimen
$M$	bending moment
$M_j$	bending moment value, $j = 1, 2, 3$ or $4$
$M_L$	bending moment corresponding to the load at $LOP$
$b$	width of test specimen
$f_{R,j}$	residual flexural tensile strength, $j = 1, 2, 3$ or $4$
$f_{ct,L}^f$	$LOP$
$h_{sp}$	distance between the tip of the notch and the top of the test specimen in the mid-span section
$l$	length of span
$x$	width of notch
$y$	distance between bottom of test specimen and axis of displacement transducer
$\delta$	deflection
$\delta_{FL}$	deflection at $LOP$
$\delta_j$	deflection value, $j = 1, 2, 3$ or $4$

### 4.2 Abbreviations

$CMOD$	crack mouth opening displacement
$LOP$	limit of proportionality

## 5 Principle

The tensile behaviour of metallic fibre concrete is evaluated in terms of residual flexural tensile strength values determined from the load-crack mouth opening displacement curve or load-deflection curve obtained by applying a centre-point load on a simply supported notched prism.

## 6 Apparatus

- 6.1** Saw with rotating carborundum or diamond blade with adjustable and fixable cutting depth and 90° direction of saw-cut to the specimens lengths for notching the test specimens.
- 6.2** Calliper, capable of reading the dimensions of test specimens to an accuracy of 0,1 mm.
- 6.3** Rule, capable of reading the dimensions of test specimens to an accuracy of 1 mm.
- 6.4** Testing machine meeting the machine class 1 requirements in EN 12390-4, capable of operating in a controlled manner i.e. producing a constant rate of displacement (*CMOD* or deflection), and with sufficient stiffness to avoid unstable zones in the load-*CMOD* curve or load-deflection curve.
- 6.5** Device for transmitting the load of the testing machine to the test specimen, made up of two supporting rollers and one loading roller (see Figure 1).

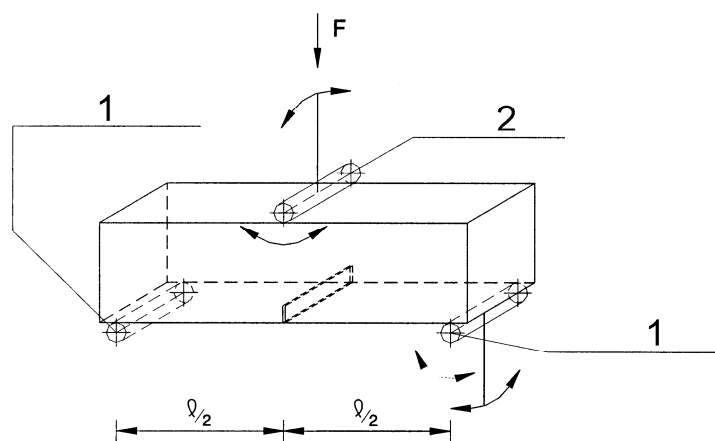

### Key

- 1 Supporting roller  
2 Loading roller

**Figure 1 — Arrangement of loading of test specimen**

All rollers shall be manufactured from steel and shall have a circular cross-section with a diameter of  $30 \text{ mm} \pm 1 \text{ mm}$ . They shall be at least 10 mm longer than the width of the test specimen. They shall have a clean and smooth surface.

Two rollers, including the upper one, shall be capable of rotating freely around their axis and of being inclined in a plane perpendicular to the longitudinal axis of the test specimen.

The distance between the centres of the supporting rollers (i.e. the span length) shall be equal to 500 mm. All rollers shall be adjusted to their correct position with all distances having an accuracy of  $\pm 2,0 \text{ mm}$ .

- 6.6** Load measuring device, capable of measuring loads to an accuracy of 0,1 kN.



- 6.7** Linear displacement transducer(s), capable of measuring displacements to an accuracy of 0,01 mm.
- 6.8** Device (frame or jig) for mounting displacement transducer(s), capable of being installed in a manner that ensures accurate determination of net mid-span deflections excluding any effects due to seating or twisting of the test specimen on its supports (only if deflection is measured instead of *CMOD*).
- 6.9** Data recording system coupled directly to electronic outputs of load and *CMOD* or deflection, with a recording rate not less than 5 Hz.

## 7 Test specimens

### 7.1 Shape and size of test specimens

The test specimens shall be prisms conforming to EN 12390-1 with a nominal size (width and depth) of 150 mm and a length  $L$  so that  $550 \text{ mm} \leq L \leq 700 \text{ mm}$ .

The specified shape and size of test specimens are suitable for concrete with maximum size of aggregate no larger than 32 mm and/or metallic fibres no longer than 60 mm.

### 7.2 Manufacture and curing of test specimens

The test specimens shall be cast and cured in compliance with EN 12350-1 and EN 12390-2 unless specified otherwise.

The procedure for filling the mould is indicated in Figure 2; the size of increment 1 should be twice that of increment 2. The mould shall be filled up to approximately 90 % of the height of the test specimen before compaction. The mould shall be topped up and levelled off while being compacted. Compaction shall be carried out by external vibration. In the case of self-compacting metallic fibre concrete, the mould shall be filled and levelled off without any compaction.

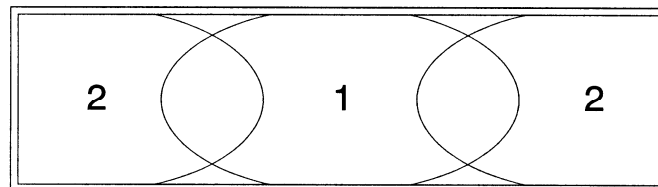

#### Key

1 and 2 order of filling

**Figure 2 — Procedure for filling the mould**

### 7.3 Notching of test specimens

Wet sawing shall be used to notch the test specimens. Specimens shall be rotated over  $90^\circ$  around their longitudinal axis and then sawn through the width of specimen at mid-span (see Figure 3).

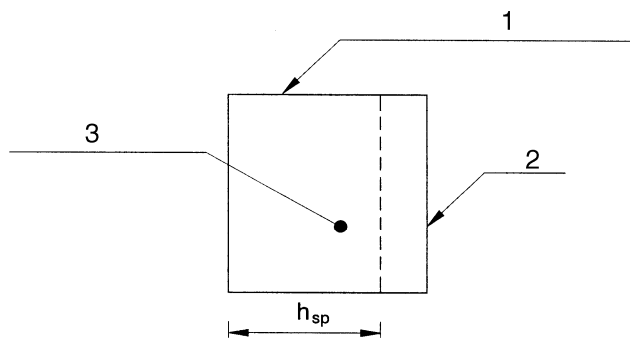

### Key

- 1 Top surface during casting
- 2 Notch
- 3 Cross-section of test specimen

**Figure 3 — Position of the notch sawn into the test specimen before rotating**

The width of the notch  $\times$  shall be 5 mm or less, the distance  $h_{sp}$  shall be  $125 \text{ mm} \pm 1 \text{ mm}$  (see Figure 4).

The test specimens shall be cured according to EN 12390-2, unless specified otherwise, for a minimum of 3 days after sawing until no more than 3 h before testing (leaving sufficient time for preparation including any location devices for the transducer(s)). Testing shall normally be performed at 28 days.

## 8 Testing procedure

### 8.1 Preparation and positioning of test specimens

The average width of the specimen and distance between the tip of the notch and the top of the specimen in the mid-span section shall be determined from two measurements to the nearest 0,1 mm of width and distance in the notched part of the test specimen, using callipers.

When the crack (or notch) mouth opening displacement is measured, a displacement transducer shall be mounted along the longitudinal axis at the mid-width of the test specimen, such that the distance  $y$  between the bottom of the specimen and the line of measurement is 5 mm or less (see Figure 4).

Dimensions in millimetres

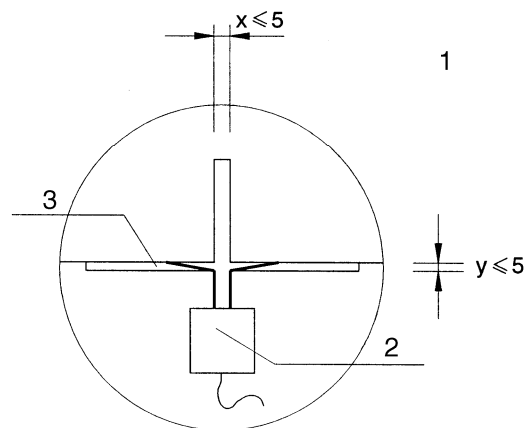
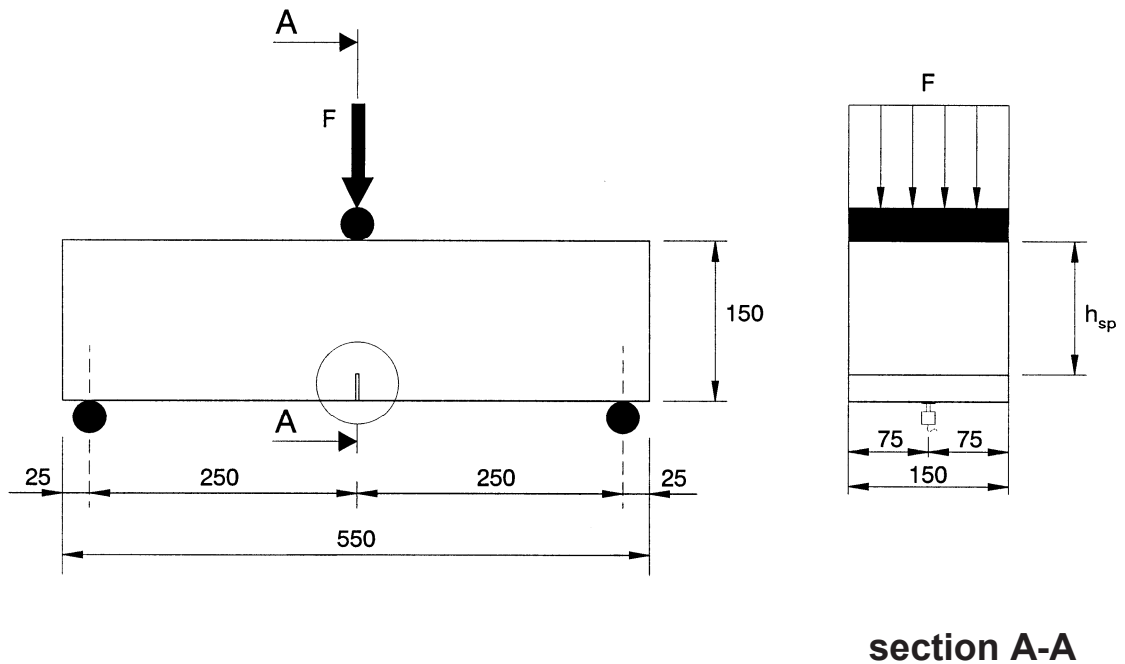
**Key**

- 1 Detail (notch)
- 2 Transducer (clip gauge)
- 3 Knife edge

**Figure 4 — Typical arrangement for measuring CMOD**

When the deflection is measured instead of the *CMOD*, a typical arrangement is as follows. A displacement transducer shall be mounted on a rigid frame that is fixed to the test specimen at mid-height over the supports (see Figure 5). One end of the frame should be fixed to the specimen with a sliding fixture and the other end with a rotating fixture. Since the transducer should measure the deflection, a thin plate fixed at one end can be placed at mid-width across the notch mouth at the point of measurement (see Figure 5).

All bearing surfaces shall be wiped clean and any loose grit or other extraneous material from the surfaces of the test specimen that will be in contact with the rollers shall be removed.

The test specimen shall be placed in the testing machine, correctly centred and with the longitudinal axis of the specimen at right angles to the longitudinal axis of the upper and lower rollers.

### 8.2 Bending test

Before the bending test, the average span length of the test specimen shall be determined from two measurements to the nearest mm of the axis distance between the supporting rollers on both sides of the specimen, using a ruler.

Dimensions in millimetres

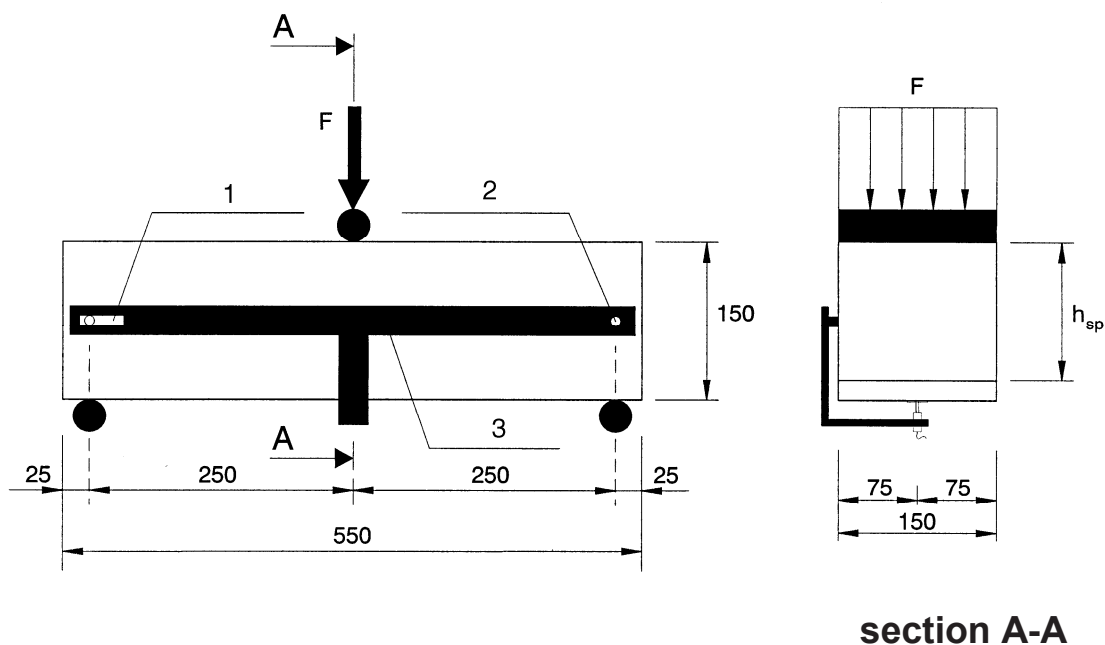

#### Key

- 1 Sliding fixture
- 2 Rotating fixture
- 3 Rigid frame

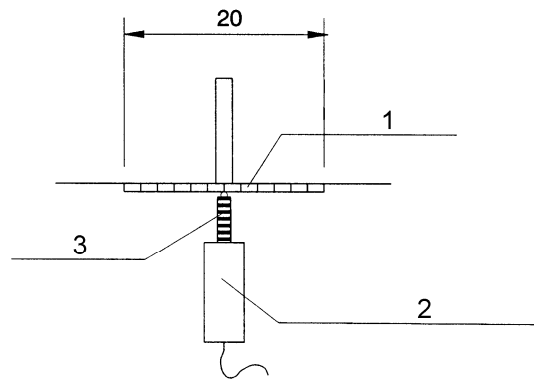

### Key

- 1 1 mm thick aluminium plate
- 2 Transducer (linear variable differential transformer)
- 3 Spring shaft

**Figure 5 — Typical arrangement for measuring deflection**

The load shall not be applied until all loading and supporting rollers are resting evenly against the test specimen.

In case of a testing machine controlling the rate of increase of *CMOD*, the machine shall be operated so that *CMOD* increases at a constant rate of 0,05 mm/min. When *CMOD* = 0,1 mm, the machine shall be operated so that *CMOD* increases at a constant rate of 0,2 mm/min.

During the first two minutes of the test, the values of the load and corresponding *CMOD* shall be recorded at a rate not less than 5 Hz, afterwards this rate may be reduced to not less than 1 Hz.

The test shall be terminated at a *CMOD* value not less than 4 mm.

In case the minimum load value in the range  $CMOD_{FL}$  to *CMOD* = 0,5 mm is less than 30 % of the load value corresponding to *CMOD* = 0,5 mm, the testing procedure shall be checked for instability.

In case of a testing machine controlling the rate of increase of deflection, the above testing procedure shall be applied provided that the *CMOD* related parameters are transformed into deflection related parameters (see 9.1).

Tests during which the crack starts outside the notch shall be rejected.

## 9 Expression of results

### 9.1 Equivalence between *CMOD* and deflection

The relation between *CMOD* and deflection may be approximated by:

$$\delta = 0,85 \text{ } CMOD + 0,04 \quad (1)$$

where

$\delta$  is the deflection, in millimetres;

$CMOD$  is the  $CMOD$  value, in millimetres, measured in case the distance between the bottom of the test specimen and the line of measurement  $y = 0$ .

In case the line of measurement is at a distance  $y$  below the bottom of the specimen, the value of  $CMOD$  shall be derived from the measured value  $CMOD_y$  using the expression:

$$CMOD = CMOD_y \cdot \frac{h}{h + y} \quad (2)$$

with

$h$  the total depth of the specimen.

To transform the load- $CMOD$  diagrams of the following Figures 6 and 7 into load-deflection diagrams, a transformation of the  $CMOD$  axis should be carried out using the  $CMOD$  and  $\delta$  values of Table 1.

**Table 1 – Relationship between  $CMOD$  and  $\delta$**

$CMOD$ (mm)	$\delta$ (mm)
0,05	0,08
0,1	0,13
0,2	0,21
0,5	0,47
1,5	1,32
2,5	2,17
3,5	3,02
4,0	3,44

## 9.2 Limit of proportionality

The  $LOP$  is given by the expression (see Annex A):

$$f_{ct,L}^f = \frac{3F_L l}{2bh_{sp}^2} \quad (3)$$

where

$f_{ct,L}^f$  is the  $LOP$ , in Newton per square millimetre;

$F_L$  is the load corresponding to the  $LOP$ , in Newton (see Figure 6);

$l$  is the span length, in millimetres;

$b$  is the width of the specimen, in millimetres;

$h_{sp}$  is the distance between the tip of the notch and the top of the specimen, in millimetres.

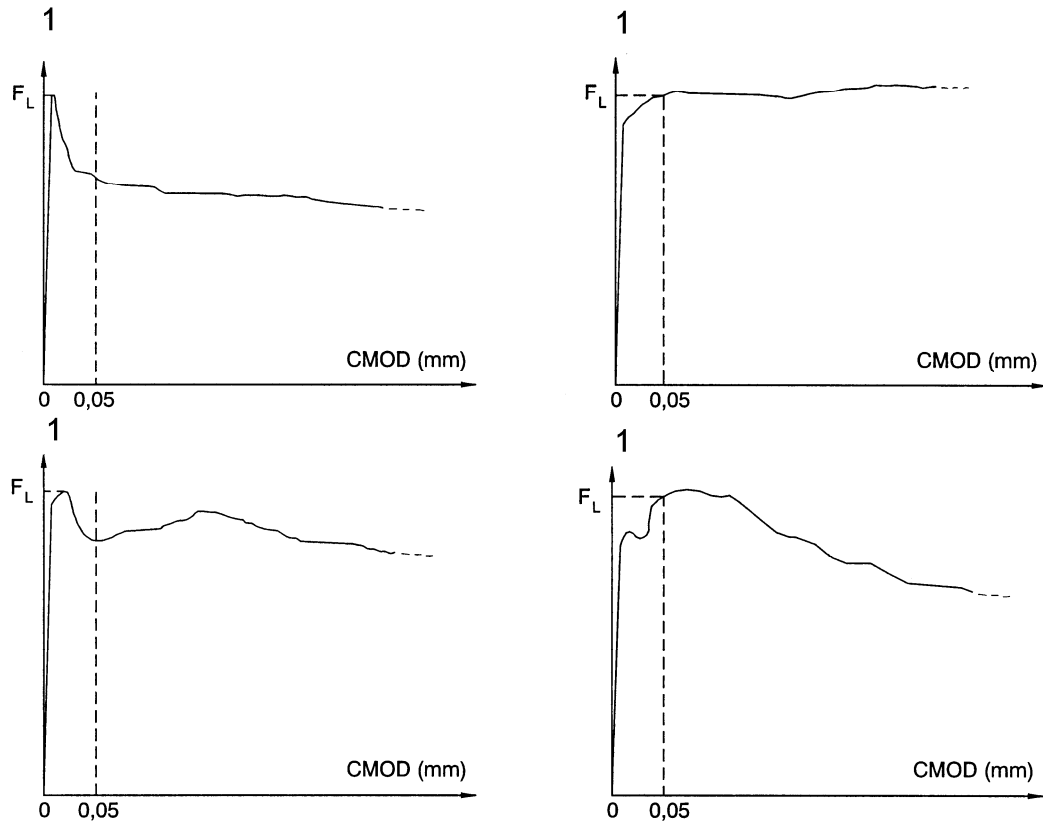

### Key

1 Load F

**Figure 6 — Load-CMOD diagrams and  $F_L$**

The load value  $F_L$  shall be determined by drawing a line at a distance of 0,05 mm and parallel to the load axis of the load-CMOD or load-deflection diagram and taking as  $F_L$  the highest load value in the interval of 0,05 mm (see Figure 6).

The *LOP* shall be expressed to the nearest 0,1 N/mm<sup>2</sup>.

### 9.3 Residual flexural tensile strength

The residual flexural tensile strength  $f_{R,j}$  is given by the expression (see Annex A):

$$f_{R,j} = \frac{3F_j l}{2bh_{sp}^2} \quad (4)$$

where

$f_{R,j}$  is the residual flexural tensile strength corresponding with  $CMOD = CMOD_j$  or  $\delta = \delta_j$  ( $j = 1,2,3,4$ ), in Newton per square millimetre;

$F_j$  is the load corresponding with  $CMOD = CMOD_j$  or  $\delta = \delta_j$  ( $j = 1,2,3,4$ ), in Newton (see Figure 7);

$l$  is the span length, in millimetres;

$b$  is the width of the specimen, in millimetres;

$h_{sp}$  is the distance between the tip of the notch and the top of the specimen, in millimetres.

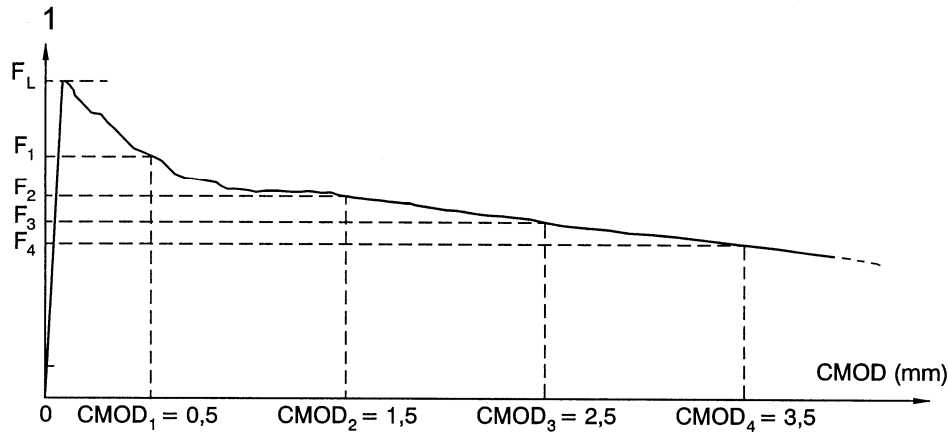

### Key

1 Load F

**Figure 7 — Load-CMOD diagram and  $F_j$  ( $j = 1, 2, 3, 4$ )**

The residual flexural tensile strength shall be expressed to the nearest 0,1 N/mm<sup>2</sup>.

## 10 Test report

The test report shall include:

- a) identification of the test specimen;
- b) identification of the concrete composition;
- c) date of manufacture;
- d) date of notching;
- [A1]** e) place and date of testing, testing institute and person responsible for testing; **[A1]**
- f) number of specimens tested;
- g) curing history and moisture condition of specimen at test;
- h) average width of specimen to the nearest 0,1 mm;
- l) average distance between the tip of the notch and the top of the specimen to the nearest 0,1 mm;
- j) dimensions  $x$  and  $y$ , in mm (see Figure 4);
- k) span length to the nearest mm;



- l) rate of increase of *CMOD* or deflection and any deviation thereof;
- m) load-*CMOD* curve or load-deflection curve;
- n) *LOP* to the nearest 0,1 N/mm<sup>2</sup>;
- o) residual flexural tensile strength values corresponding to  $CMOD_j$  or  $\delta_j$  ( $j = 1,2,3,4$ ) to the nearest 0,1 N/mm<sup>2</sup>;
- p) reference to this European Standard;
- q) any deviation from the standard testing method;
- r) optionally, observation of uniformity of fibre distribution at the fracture surface;
- s) declaration from the person technically responsible for the test that the testing was carried out in accordance with this standard, except for the indicated deviation(s).

## 11 Precision

There is currently no precision data for this test.

## Annex A (informative)

### Expressions for limit of proportionality and for residual flexural tensile strength

The bending moment at mid-span of the test specimen corresponding to the centre-point load  $F$  is (see Figure 1):

$$M = \frac{F}{2} \cdot \frac{l}{2} \quad (5)$$

where

$l$  is the span length.

Assuming a linear stress distribution as shown in Figure A.1,

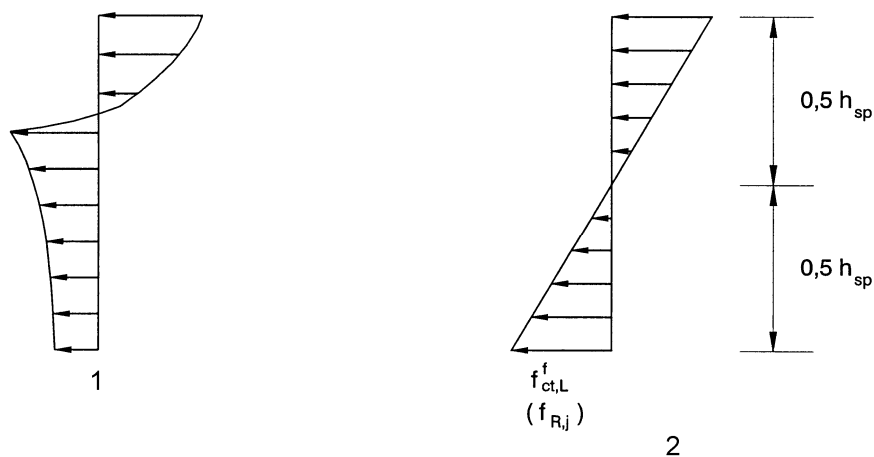

#### Key

- 1 Real stress distribution
- 2 Assumed stress distribution

**Figure A.1 — Stress distributions**

the LOP  $f_{ct,L}^f$  is given by the expression:

$$f_{ct,L}^f = \frac{6M_L}{bh_{sp}^2} = \frac{3F_L l}{2bh_{sp}^2} \quad (6)$$

and the residual flexural tensile strength  $f_{R,j}$  ( $j = 1,2,3,4$ ) by the expression:

$$f_{R,j} = \frac{6M_j}{bh_{sp}^2} = \frac{3F_j l}{2bh_{sp}^2} \quad (7)$$

where

$F_L$  is the load corresponding to the *LOP*;

$F_j$  is the load corresponding to *CMOD* <sub>$j$</sub>  or  $\delta_j$  ( $j = 1,2,3,4$ );

$M_L$  is the bending moment corresponding to the load at *LOP*;

$M_j$  is the bending moment corresponding to the load  $F_j$  ( $j = 1,2,3,4$ );

$b$  is the width of the specimen;

$h_{sp}$  is the distance between the tip of the notch and the top of the specimen in the mid-span section.

---

---

# BSI — British Standards Institution

BSI is the independent national body responsible for preparing British Standards. It presents the UK view on standards in Europe and at the international level. It is incorporated by Royal Charter.

## Revisions

British Standards are updated by amendment or revision. Users of British Standards should make sure that they possess the latest amendments or editions.

It is the constant aim of BSI to improve the quality of our products and services. We would be grateful if anyone finding an inaccuracy or ambiguity while using this British Standard would inform the Secretary of the technical committee responsible, the identity of which can be found on the inside front cover.  
Tel: +44 (0)20 8996 9000. Fax: +44 (0)20 8996 7400.

BSI offers members an individual updating service called PLUS which ensures that subscribers automatically receive the latest editions of standards.

## Buying standards

Orders for all BSI, international and foreign standards publications should be addressed to Customer Services. Tel: +44 (0)20 8996 9001.  
Fax: +44 (0)20 8996 7001. Email: [orders@bsi-global.com](mailto:orders@bsi-global.com). Standards are also available from the BSI website at <http://www.bsi-global.com>.

In response to orders for international standards, it is BSI policy to supply the BSI implementation of those that have been published as British Standards, unless otherwise requested.

## Information on standards

BSI provides a wide range of information on national, European and international standards through its Library and its Technical Help to Exporters Service. Various BSI electronic information services are also available which give details on all its products and services. Contact the Information Centre.  
Tel: +44 (0)20 8996 7111. Fax: +44 (0)20 8996 7048. Email: [info@bsi-global.com](mailto:info@bsi-global.com).

Subscribing members of BSI are kept up to date with standards developments and receive substantial discounts on the purchase price of standards. For details of these and other benefits contact Membership Administration.  
Tel: +44 (0)20 8996 7002. Fax: +44 (0)20 8996 7001.  
Email: [membership@bsi-global.com](mailto:membership@bsi-global.com).

Information regarding online access to British Standards via British Standards Online can be found at <http://www.bsi-global.com/bsonline>.

Further information about BSI is available on the BSI website at <http://www.bsi-global.com>.

## Copyright

Copyright subsists in all BSI publications. BSI also holds the copyright, in the UK, of the publications of the international standardization bodies. Except as permitted under the Copyright, Designs and Patents Act 1988 no extract may be reproduced, stored in a retrieval system or transmitted in any form or by any means – electronic, photocopying, recording or otherwise – without prior written permission from BSI.

This does not preclude the free use, in the course of implementing the standard, of necessary details such as symbols, and size, type or grade designations. If these details are to be used for any other purpose than implementation then the prior written permission of BSI must be obtained.

Details and advice can be obtained from the Copyright & Licensing Manager.  
Tel: +44 (0)20 8996 7070. Fax: +44 (0)20 8996 7553.  
Email: [copyright@bsi-global.com](mailto:copyright@bsi-global.com).