

Precast concrete products — Concrete with wood-chips as aggregate — Requirements and test methods

The European Standard EN 14474:2004 has the status of a
British Standard

ICS 91.100.30

National foreword

This British Standard is the official English language version of EN 14474:2004.

The UK participation in its preparation was entrusted to Technical Committee B/524, Precast concrete products, which has the responsibility to:

- aid enquirers to understand the text;
- present to the responsible international/European committee any enquiries on the interpretation, or proposals for change, and keep the UK interests informed;
- monitor related international and European developments and promulgate them in the UK.

A list of organizations represented on this committee can be obtained on request to its secretary.

Cross-references

The British Standards which implement international or European publications referred to in this document may be found in the *BSI Catalogue* under the section entitled “International Standards Correspondence Index”, or by using the “Search” facility of the *BSI Electronic Catalogue* or of British Standards Online.

This publication does not purport to include all the necessary provisions of a contract. Users are responsible for its correct application.

Compliance with a British Standard does not of itself confer immunity from legal obligations.

Summary of pages

This document comprises a front cover, an inside front cover, the EN title page, pages 2 to 13 and a back cover.

The BSI copyright notice displayed in this document indicates when the document was last issued.

Amendments issued since publication

Amd. No.	Date	Comments

This British Standard was published under the authority of the Standards Policy and Strategy Committee on 8 February 2005

© BSI 8 February 2005

ISBN 0 580 45415 0

ICS 91.100.30

English version

Precast concrete products - Concrete with wood-chips as aggregate - Requirements and test methods

Produits préfabriqués en béton - Béton utilisant des copeaux de bois comme granulats - Exigences et méthodes d'essai

Betonfertigteile - Holzspanbeton - Anforderungen und Prüfverfahren

This European Standard was approved by CEN on 15 November 2004.

CEN members are bound to comply with the CEN/CENELEC Internal Regulations which stipulate the conditions for giving this European Standard the status of a national standard without any alteration. Up-to-date lists and bibliographical references concerning such national standards may be obtained on application to the Central Secretariat or to any CEN member.

This European Standard exists in three official versions (English, French, German). A version in any other language made by translation under the responsibility of a CEN member into its own language and notified to the Central Secretariat has the same status as the official versions.

CEN members are the national standards bodies of Austria, Belgium, Cyprus, Czech Republic, Denmark, Estonia, Finland, France, Germany, Greece, Hungary, Iceland, Ireland, Italy, Latvia, Lithuania, Luxembourg, Malta, Netherlands, Norway, Poland, Portugal, Slovakia, Slovenia, Spain, Sweden, Switzerland and United Kingdom.



EUROPEAN COMMITTEE FOR STANDARDIZATION
COMITÉ EUROPÉEN DE NORMALISATION
EUROPÄISCHES KOMITEE FÜR NORMUNG

Management Centre: rue de Stassart, 36 B-1050 Brussels

Contents

Page

Foreword.....	3
1 Scope	4
2 Normative references	4
3 Terms and definitions	4
4 Requirements	5
5 Tests.....	6
6 Evaluation of conformity.....	8
Annex A (normative) Determination of frost-resistance or frost-resistance in the presence of de-icing salts	10
Bibliography	13

Foreword

This document (EN 14474:2004) has been prepared by Technical Committee CEN/TC 229 "Precast concrete products", the secretariat of which is held by AFNOR.

This European Standard shall be given the status of a national standard, either by publication of an identical text or by endorsement, at the latest by June 2005, and conflicting national standards shall be withdrawn at the latest by June 2005.

NOTE The term: "**Concrete with wood-chips as aggregate**" is hereinafter referred to as: "**wood-chip concrete**".

This document gives general requirements for wood-chip concrete products. Product standards may adopt these requirements, when appropriate to the product or the application.

According to the CEN/CENELEC Internal Regulations, the national standards organizations of the following countries are bound to implement this European Standard: Austria, Belgium, Cyprus, Czech Republic, Denmark, Estonia, Finland, France, Germany, Greece, Hungary, Iceland, Ireland, Italy, Latvia, Lithuania, Luxembourg, Malta, Netherlands, Norway, Poland, Portugal, Slovakia, Slovenia, Spain, Sweden, Switzerland and United Kingdom.

1 Scope

This document specifies common requirements for wood-chip concrete, used in precast wood-chip concrete products. It is intended to be used when preparing documents for wood-chip concrete products. Wood-chip concrete product standards will define specific requirements, which may be additional to those given in this document. Product standards will give any limiting values.

Examples for the use of wood-chip concrete are: hollow blocks for flooring systems, shuttering blocks, slabs, facing elements, acoustic and/or thermal facing elements, partitioning elements, wine racks, etc.

It is not applicable to concrete for structural masonry units covered by EN 771-3 and their ancillary components.

2 Normative references

The following referenced documents are indispensable for the application of this document. For dated references, only the edition cited applies. For undated references, the latest edition of the referenced document (including any amendments) applies.

EN 772-11, *Methods of test for masonry units - Part 11: Determination of water absorption of aggregate concrete, manufactured stone and natural stone masonry units due to capillary action and the initial rate of water absorption of clay masonry units*

EN 772-14, *Methods of test for masonry units - Part 14: Determination of moisture movement of aggregate concrete and manufactured stone masonry units*

EN 12390-3, *Testing hardened concrete – Part 3: Compressive strength of test specimens*

EN 12390-5, *Testing hardened concrete – Part 5: Flexural strength of test specimens*

EN 12664, *Thermal performance of building materials and products - Determination of thermal resistance by means of guarded hot plate and heat flow meter methods - Dry and moist products of medium and low thermal resistance*

EN 12779:2004, *Safety of woodworking machines – Chip and dust extraction systems with fixed installation – Safety related performances and safety requirements*

EN 13501-1, *Fire classification of construction products and building elements - Part 1: Classification using test data from reaction to fire tests*

EN 13823, *Reaction to fire tests for building products – Building products excluding floorings exposed to the thermal attack by a single burning item*

EN ISO 354, *Acoustics - Measurement of sound absorption in a reverberation room (ISO 354:2003)*

EN ISO 10456, *Building materials and products - Procedures for determining declared and design thermal values (ISO 10456:1999)*

3 Terms and definitions

For the purposes of this document, the following terms and definitions apply.

3.1

wood-chip concrete

open structure concrete with 50% to 90% by volume (according to use) of the aggregate being wood-chips

3.2

wood-chip

aggregates as defined in EN 12779:2004, 3.1.3

4 Requirements

4.1 Materials

The specifications of the materials to be used shall be included in the production control documentation (see 6.3). If appropriate documents are available, they shall be used except that aggregates need not comply with grading requirements. If not available, the manufacturer shall specify the materials and have data on their suitability.

4.2 Properties of wood-chip concrete

4.2.1 General

The main properties of wood-chip concrete are defined below.

Product standards may identify additional properties.

4.2.2 Density

The oven-dry density shall be between 450 kg/m³ and 1 200 kg/m³ according to use.

The design value of dry density shall be given and determined according to 5.2. The mean oven-dry density of wood-chip concrete shall not deviate by more than $\pm 10\%$ from the declared value. Individual values of oven-dry density shall not deviate by more than $\pm 15\%$ from the declared value.

4.2.3 Strength

When required, flexural and/or compressive strength shall be determined according to 5.3.

4.2.4 Thermal conductivity

When required, thermal conductivity (λ) shall be given as a design value and determined according to 5.4.

4.2.5 Sound absorption

When required, the sound-absorption coefficient shall be given and determined according to 5.5.

4.2.6 Frost-resistance

When required, the frost-resistance or the frost-resistance in the presence of de-icing salts of unprotected wood-chip concrete shall be declared on the basis of long-term experience or testing.

Tests shall be carried out according to 5.6.

Loss of mass shall be not more than 10 % and shall not affect more than 5 mm depth.

4.2.7 Reaction to fire

When required, reaction to fire shall be given and determined according to 5.7.

4.2.8 Shrinkage and expansion

When required, shrinkage and expansion of wood-chip concrete shall be given and determined according to 5.8.

4.2.9 Water absorption

When required, water absorption by capillarity shall be given and determined according to 5.9.

5 Tests

5.1 Test specimens

5.1.1 General

The properties of wood-chip concrete may be tested on specimens either cast from product mixes or cut from products.

Methods of preparing test specimens cut from products shall be as given in test standards or as specified in product standards.

Test specimens cut from products shall have a minimum volume of $3\,000 \times 10^3 \text{ mm}^3$.

5.1.2 Dimensions of cast test specimens

Test specimens with the dimensions $800 (\pm 5) \text{ mm} \times 150 (\pm 5) \text{ mm} \times 150 (\pm 5) \text{ mm}$ shall be produced from the product mix of the current production for tests according to 5.2, 5.3, 5.6 and 5.9. Subsequently, test cubes with the minimum dimensions $150 (\pm 5) \text{ mm} \times 150 (\pm 5) \text{ mm} \times 150 (\pm 5) \text{ mm}$ may be cut from the initial test specimens.

Test specimens cut from products may also be used.

5.1.3 Mould for cast test specimens

Steel mould (see Figure 1) with minimum dimensions of $800 (\pm 5) \text{ mm} \times 150 (\pm 5) \text{ mm} \times 150 (\pm 5) \text{ mm}$, equipped with a filling frame of minimum height $h_c \geq 40 \text{ mm}$ and a tamper for compacting the specimens to the required height and density.

Dimensions in millimetres

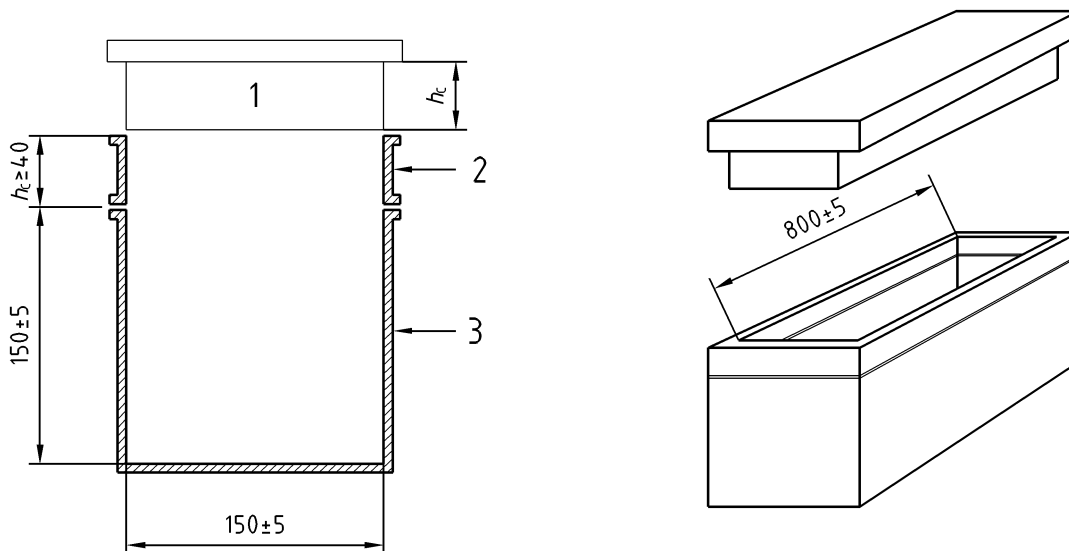
**Key**

- 1 Tamper
- 2 Filling frame
- 3 Steel mould

Figure 1 — Schematic diagram**5.1.4 Mould filling and compacting**

Care shall be taken to ensure consistency of filling and compaction.

The mould shall be filled with fresh product mix and the top struck off with a steel rule to produce a level surface.

The mixture shall then be compacted manually and/or mechanically. The appropriate filling frame height h_c /density relationship shall be established by type tests.

After 24 h the load and the tamper shall be removed, the test specimen demoulded, weighed, labelled with the production date and filling direction and stored for a reference period of 28 days (7 days in humid conditions followed by 21 days dry storage). Storage in ambient conditions may be used, provided a good correlation is established with above conditions. The dry storage period may be reduced if proof of a good correlation can be established between the characteristics measured for the reduced period compared to the characteristics after 28 days.

5.1.5 Preparation and storage of test cubes

If required, the test specimens may be cut into cubes after the storage period. The cubes shall also be labelled with the production date and filling direction and shall be dry stored until the testing date.

5.2 Dry density

The oven-dry density of the wood-chip concrete shall be established using test specimens prepared according to 5.1 dried to constant mass at a temperature of $(+105 \pm 2) ^\circ\text{C}$.

Constant mass is considered to be reached when the results of two successive weighing operations, carried out at an interval of 24 h, do not differ by more than 0,5 % of the mass of the test specimens.

Specimens shall be measured to the nearest millimetre and weighed to an accuracy of 1 gram. The density shall be calculated to the nearest 10 kg/m³.

Density shall be established as the mean value of 3 test specimens.

5.3 Strength

Flexural strength shall be tested according to EN 12390-5 and compressive strength according to EN 12390-3 on test specimens prepared as described in 5.1.

5.4 Thermal conductivity

Thermal conductivity shall be determined according to EN 12664.

Design values of thermal conductivity shall be obtained by converting measured values according to EN ISO 10456.

5.5 Sound absorption

Sound absorption shall be determined according to EN ISO 354.

5.6 Frost-resistance

Frost resistance or frost resistance in the presence of de-icing salts shall be determined according to Annex A on 3 specimens prepared as described in 5.1.

5.7 Reaction to fire

Reaction to fire shall be tested according to EN 13823 and classified in accordance with EN 13501-1.

5.8 Shrinkage and expansion

Shrinkage and expansion shall be determined according to EN 772-14.

5.9 Water absorption

Water absorption by capillarity shall be determined according to EN 772-11.

6 Evaluation of conformity

6.1 General

Evaluation of conformity requirements shall be given in product standards.

Compliance with the requirements of this document and with the declared values of properties shall be demonstrated by carrying out both:

- initial type testing of wood-chip concrete;
- factory production control.

6.2 Initial type tests

Initial type testing shall be carried out before a new type of material is put on the market.

When a new type of wood-chip concrete or a new production method is developed, initial type tests shall be carried out to confirm that the achieved properties meet the requirements of this document and the values to be declared for it. Whenever a major change occurs in raw materials, mix design or the production process which would change the properties of the wood-chip concrete, the appropriate initial type tests shall be repeated.

The type tests shall be the reference tests described in this document or in the relevant product standard consistent with the producer's declaration for the intended use.

Test methods shall be given in product standards.

The result of the initial tests shall be recorded.

6.3 Factory production control

6.3.1 General

A factory production control system shall be established, maintained and documented.

The factory production control system shall consist of procedures for the internal control of production to ensure that the wood-chip concrete conforms to this document and the producer's declared values.

6.3.2 Raw materials

As appropriate, the specifications of the incoming materials and the procedures to be operated to ensure that they comply shall be documented.

6.3.3 Production process

As appropriate, the relevant features of the plant and production process shall be defined giving the frequency of the inspection checks and tests, together with the criteria required both on equipment and on work in progress. The action to be taken when control values or criteria are not met shall be given. Measuring equipment shall be verified and the procedure, frequency and criteria documented.

6.3.4 Material testing

As appropriate, a sampling plan and the conformity criteria shall be prepared for the testing of materials. The results of which shall be recorded. All test equipment shall be verified and the procedure, frequency and criteria documented.

Annex A (normative)

Determination of frost-resistance or frost-resistance in the presence of de-icing salts

A.1 Principle

Specimens are subjected to a series of freeze thaw cycles after which the loss of mass is determined and expressed as a percentage of the initial mass of the specimens.

A.2 Apparatus

A.2.1 Freezer unit

A freezer unit having forced air circulation capable of lowering the temperature to (-15 ± 2) °C within one or two hours when containing the batch of test specimens.

A.2.2 Water bath

A water bath capable of maintaining the contents at a temperature of $(+20 \pm 2)$ °C and regaining this temperature in not more than two hours after inserting a full load of frozen test specimens.

The dimensions of the water bath shall be sufficient to accommodate a batch of test specimens and warrant the clearance described under A.4.2.

A.2.3 Measuring device

A measuring device capable of measuring temperatures from -30 °C to $+50$ °C to an accuracy of 1 °C.

A.2.4 Balance

A balance with an accuracy of 1 gram.

A.2.5 Climatic chamber or cabinet

A climatic chamber or cabinet capable of maintaining a temperature of $(+20 \pm 2)$ °C and a relative humidity of (65 ± 5) %.

A.3 Test specimen

The dimensions of test specimens are specified in 5.1.2.

Test specimens shall be at least 28 days old. The test batch comprises three test specimens with a total volume of not less than $9\,000$ cm³.

A.4 Procedure for determination of frost resistance without de-icing salt

A.4.1 Determination of initial mass

Determine the initial mass (IM) of the test specimen to the nearest gram after conditioning to constant mass in an atmosphere with a relative humidity of $(65 \pm 5) \%$ and at a temperature of $(20 \pm 2) ^\circ\text{C}$.

Constant mass is considered to be reached when the results of two successive weighings, carried out at an interval of 24 h, do not differ by more than 0,5 % of the mass of the test specimens.

A.4.2 Freeze-thaw cycle

Immerse the test specimens in water at a temperature of $(+20 \pm 2) ^\circ\text{C}$ for 48 h.

Subject the test specimens to a sequence of freeze-thaw cycles. Replace the water in the bath for each thawing phase of the cycle.

Place the specimens in the freezer at $(-15 \pm 2) ^\circ\text{C}$ and hold this temperature for a further hour after this temperature has been regained.

Remove the specimens from the freezer and place them in the water bath at $(20 \pm 2) ^\circ\text{C}$.

Place test specimens in the water bath with at least 20 mm of water above their top surface.

Raise the temperature of the water back to $(20 \pm 2) ^\circ\text{C}$ and maintain this temperature for between 1 h and 2 h.

After each cycle turn the test specimens.

During both the cooling and heating (freezing and thawing) cycles the test specimens shall be positioned so as to enable free circulation of the conducting medium (air in the freezer or water in the bath) around them. The clearance between any edge or face, except for the contact with discontinuous supports, shall be at least 10 mm.

Repeat the freeze thaw cycle 24 times unless otherwise stated.

A.4.3 Determination of final mass

Determine the final mass (FM) of the specimens after 25 freeze-thaw cycles according to A.4.1.

A.4.4 Determination of loss of mass

Express the loss of mass (LM) as a percentage of the initial mass using the following formula:

$$\text{LM} = \frac{(\text{IM} - \text{FM})}{\text{IM}} \times 100$$

A.5 Procedure for determination of frost resistance in the presence of de-icing salt

Use the procedure described in A.4 but with the water in the water bath replaced with a 3 % NaCl (30g NaCl /litre water) solution according to A.4.2.

A.6 Test report

The following shall be recorded in the test report:

- a) name of test station;
- b) number and size of test specimens;
- c) date and method of manufacture of the test specimens;
- d) test date;
- e) mass of test specimens according to A.4.1 and A.4.3;
- f) loss of mass according to A.4.4.

Bibliography

- [1] EN 771-3:2003, *Specification for masonry units - Part 3: Aggregate concrete masonry units (Dense and light-weight aggregates)*

BSI — British Standards Institution

BSI is the independent national body responsible for preparing British Standards. It presents the UK view on standards in Europe and at the international level. It is incorporated by Royal Charter.

Revisions

British Standards are updated by amendment or revision. Users of British Standards should make sure that they possess the latest amendments or editions.

It is the constant aim of BSI to improve the quality of our products and services. We would be grateful if anyone finding an inaccuracy or ambiguity while using this British Standard would inform the Secretary of the technical committee responsible, the identity of which can be found on the inside front cover.
Tel: +44 (0)20 8996 9000. Fax: +44 (0)20 8996 7400.

BSI offers members an individual updating service called PLUS which ensures that subscribers automatically receive the latest editions of standards.

Buying standards

Orders for all BSI, international and foreign standards publications should be addressed to Customer Services. Tel: +44 (0)20 8996 9001.
Fax: +44 (0)20 8996 7001. Email: orders@bsi-global.com. Standards are also available from the BSI website at <http://www.bsi-global.com>.

In response to orders for international standards, it is BSI policy to supply the BSI implementation of those that have been published as British Standards, unless otherwise requested.

Information on standards

BSI provides a wide range of information on national, European and international standards through its Library and its Technical Help to Exporters Service. Various BSI electronic information services are also available which give details on all its products and services. Contact the Information Centre.
Tel: +44 (0)20 8996 7111. Fax: +44 (0)20 8996 7048. Email: info@bsi-global.com.

Subscribing members of BSI are kept up to date with standards developments and receive substantial discounts on the purchase price of standards. For details of these and other benefits contact Membership Administration.
Tel: +44 (0)20 8996 7002. Fax: +44 (0)20 8996 7001.
Email: membership@bsi-global.com.

Information regarding online access to British Standards via British Standards Online can be found at <http://www.bsi-global.com/bsonline>.

Further information about BSI is available on the BSI website at <http://www.bsi-global.com>.

Copyright

Copyright subsists in all BSI publications. BSI also holds the copyright, in the UK, of the publications of the international standardization bodies. Except as permitted under the Copyright, Designs and Patents Act 1988 no extract may be reproduced, stored in a retrieval system or transmitted in any form or by any means – electronic, photocopying, recording or otherwise – without prior written permission from BSI.

This does not preclude the free use, in the course of implementing the standard, of necessary details such as symbols, and size, type or grade designations. If these details are to be used for any other purpose than implementation then the prior written permission of BSI must be obtained.

Details and advice can be obtained from the Copyright & Licensing Manager.
Tel: +44 (0)20 8996 7070. Fax: +44 (0)20 8996 7553.
Email: copyright@bsi-global.com.