



BSI Standards Publication

Thermal insulating products for buildings — In-situ formed sprayed rigid polyurethane (PUR) and polyisocyanurate (PIR) foam products

Part 2: Specification for the installed
insulation products

National foreword

This British Standard is the UK implementation of EN 14315-2:2013.

The UK participation in its preparation was entrusted to Technical Committee PRI/72, Rigid cellular materials.

A list of organizations represented on this committee can be obtained on request to its secretary.

This publication does not purport to include all the necessary provisions of a contract. Users are responsible for its correct application.

© The British Standards Institution 2013.
Published by BSI Standards Limited 2013.

ISBN 978 0 580 53442 3

ICS 91.100.60

Compliance with a British Standard cannot confer immunity from legal obligations.

This British Standard was published under the authority of the Standards Policy and Strategy Committee on 31 January 2013.

Amendments issued since publication

Date	Text affected
------	---------------

ICS 91.100.60

English Version

Thermal insulating products for buildings - In-situ formed
sprayed rigid polyurethane (PUR) and polyisocyanurate (PIR)
foam products - Part 2: Specification for the installed insulation
products

Produits isolants thermiques destinés aux applications du
bâtiment - Produits en mousse rigide de polyuréthane
(PUR) ou de polyisocyanurate (PIR) projetée, formés en
place - Partie 2 : Spécifications relatives aux produits
isolants après mise en oeuvre

Wärmedämmstoffe für das Bauwesen - An der
Verwendungsstelle hergestellter Wärmedämmstoff aus
Polyurethan(PUR)- und Polyisocyanurat(PIR)-Spritzschäum
- Teil 2: Spezifikation für die eingebauten Produkte

This European Standard was approved by CEN on 17 November 2012.

CEN members are bound to comply with the CEN/CENELEC Internal Regulations which stipulate the conditions for giving this European Standard the status of a national standard without any alteration. Up-to-date lists and bibliographical references concerning such national standards may be obtained on application to the CEN-CENELEC Management Centre or to any CEN member.

This European Standard exists in three official versions (English, French, German). A version in any other language made by translation under the responsibility of a CEN member into its own language and notified to the CEN-CENELEC Management Centre has the same status as the official versions.

CEN members are the national standards bodies of Austria, Belgium, Bulgaria, Croatia, Cyprus, Czech Republic, Denmark, Estonia, Finland, Former Yugoslav Republic of Macedonia, France, Germany, Greece, Hungary, Iceland, Ireland, Italy, Latvia, Lithuania, Luxembourg, Malta, Netherlands, Norway, Poland, Portugal, Romania, Slovakia, Slovenia, Spain, Sweden, Switzerland, Turkey and United Kingdom.



EUROPEAN COMMITTEE FOR STANDARDIZATION
COMITÉ EUROPÉEN DE NORMALISATION
EUROPÄISCHES KOMITEE FÜR NORMUNG

Management Centre: Avenue Marnix 17, B-1000 Brussels

Contents

Page

Foreword.....	3
1 Scope.....	4
2 Normative references.....	4
3 Terms, definitions, symbols and abbreviations.....	4
3.1 Terms and definitions	4
3.2 Symbols and abbreviations	6
4 Requirements	6
4.1 General	6
4.2 Suitability of the building for the installation of the product	6
5 In-situ measurements and calculations	6
5.1 Declared installed insulation thickness	6
5.2 Declared installed aged thermal resistance, R_D	6
5.3 Declared installed insulation density.....	6
5.4 Foam quality checks carried out by the installer.....	7
6 Guidelines for installation.....	7
7 Installer's declaration.....	7
Annex A (normative) Method of the determination of the declared installed insulation thickness	8
Procedure.....	8
Annex B (normative) Methods for the determination of the declared installed insulation density	9
B.1 Principle.....	9
B.2 Procedure	9
B.2.1 General	9
B.2.2 Destructive testing.....	9
B.2.3 Non-destructive testing	9
B.3 Test report	9
Annex C (normative) Immersion method for the determination of the declared installed insulation density	10
C.1 Scope.....	10
C.2 Principles.....	10
C.3 Necessary equipment	10
C.4 Products and reagents.....	10
C.5 Procedure	10
C.6 Results.....	11
Annex D (normative) Suitability of the building to receive the insulation product	12
D.1 Building	12
D.2 Site survey.....	12
Annex E (normative) Installation guidelines	13
E.1 General	13
E.2 Substrate preparation	13
E.3 Substrate conditions.....	13
E.4 Spraying machine preparation	13
E.4.1 Preparation.....	13
E.4.2 Mixing ratio.....	13
E.5 Spraying procedure	14
E.6 Protection against UV radiation.....	14
E.7 An example of a suitable declaration form which can be used by the installer	15
Bibliography.....	16

Foreword

This document (EN 14315-2:2013) has been prepared by Technical Committee CEN/TC 88 “Thermal insulating materials and products”, the secretariat of which is held by DIN.

This European Standard shall be given the status of a national standard, either by publication of an identical text or by endorsement, at the latest by July 2013, and conflicting national standards shall be withdrawn at the latest by July 2013.

Attention is drawn to the possibility that some of the elements of this document may be the subject of patent rights. CEN [and/or CENELEC] shall not be held responsible for identifying any or all such patent rights.

This European Standard consists of two parts which form a package. The first part is the harmonised part satisfying the mandate and the CPD and which is the basis for the CE marking covering the products, which are placed on the market. The second part, which is the non-harmonised part, covers the specification for the installed products. Both parts need to be used for the application of the insulation products in the end-use applications covered by EN 14315.

Attention is drawn to the need to take into account any complementary member state rules (e.g. installation rules) which together with this Part 2 of this European Standard ensures the fitness for purpose of the installed product.

This European Standard is one of a series for mineral wool, expanded clay, expanded perlite, exfoliated vermiculite, polyurethane/polyisocyanurate, cellulose, bound expanded polystyrene and expanded polystyrene in-situ formed insulation products used in buildings, but this standard may be used in other areas where appropriate.

The reduction in energy used and emissions produced during the installed life of insulation products exceeds by far the energy used and emissions made during the production and disposal processes.

EN 14315, *Thermal insulating products for buildings — In-situ formed sprayed rigid polyurethane (PUR) and polyisocyanurate (PIR) foam products*, consists of the following parts:

- *Part 1: Specification for the rigid foam spray system before installation*
- *Part 2: Specification for the installed insulation products* (the present document)

According to the CEN/CENELEC Internal Regulations, the national standards organisations of the following countries are bound to implement this European Standard: Austria, Belgium, Bulgaria, Croatia, Cyprus, Czech Republic, Denmark, Estonia, Finland, Former Yugoslav Republic of Macedonia, France, Germany, Greece, Hungary, Iceland, Ireland, Italy, Latvia, Lithuania, Luxembourg, Malta, Netherlands, Norway, Poland, Portugal, Romania, Slovakia, Slovenia, Spain, Sweden, Switzerland, Turkey and the United Kingdom.

1 Scope

This European Standard specifies requirements for in-situ formed sprayed rigid polyurethane (PUR) and polyisocyanurate (PIR) foam products when applied to walls, ceilings, roofs, suspended ceilings and floors.

This Part 2 of this European Standard is a specification for the installed insulation product.

This Part 2 of this European Standard describes, when taken together with Part 1 of EN 14315, the product characteristics that are linked to the essential requirements of the EU Construction Products Directive. It also specifies the checks and tests to be used for the declarations made by the installer of the product.

This European Standard does not specify the required levels of all properties to be achieved by a product to demonstrate fitness for purpose in a particular application. The required levels are to be found in regulations or non-conflicting standards.

This European Standard does not cover factory made rigid polyurethane (PUR) or polyisocyanurate (PIR) foam products or in-situ products intended to be used for the insulation of building equipment and industrial installations.

NOTE Foam products are either called flexible or rigid. The flexible products are used in upholstery and mattresses and are characterised by their ability to deflect, support and recover to their original thickness continually during their in-use phase. Those that are not flexible are termed rigid and do not possess these flexible characteristics. They are mostly used for thermal insulation purposes and vary widely in their compression strength values. Once the cell structure is crushed in a rigid foam, it does not recover its thickness fully. Some of these rigid foams are very low in density with very low compression strengths and are sometimes described “commercially” as “soft foams” or “semi-rigid” foams. This note has been included to clarify that all foams with such descriptions are covered by this standard’s use of the term rigid foam.

2 Normative references

The following documents, in whole or in part, are normatively referenced in this document and are indispensable for its application. For dated references, only the edition cited applies. For undated references, the latest edition of the referenced document (including any amendments) applies.

EN 1602, *Thermal insulating products for building applications — Determination of the apparent density*

EN 14315-1:2013, *Thermal insulating products for buildings — In-situ formed sprayed rigid polyurethane (PUR) and polyisocyanurate (PIR) foam products — Part 1: Specification for the foam system before installation*

EN ISO 9229:2007, *Thermal insulation — Vocabulary (ISO 9229:2007)*

3 Terms, definitions, symbols and abbreviations

3.1 Terms and definitions

For the purposes of this document, the terms and definitions given in EN ISO 9229:2007 and the following apply.

3.1.1

polyurethane foam PUR (in-situ formed products)

rigid cellular plastics insulation material or product with a structure based on polymers mainly of the polyurethane type

3.1.2

polyisocyanurate foam PIR (in-situ formed products)

rigid cellular plastics insulation material or product with a structure based on polymers mainly of the polyisocyanurate type

3.1.3

polyurethane foam PU

rigid cellular plastics insulation materials or products including both polymer types based mainly on polyurethane (PUR) or mainly on polyisocyanurate (PIR) groups

3.1.4

rigid foam spray system

kit of constituent components which when sprayed generates the rigid polyurethane (PUR) or the rigid polyisocyanurate (PIR) foam characterised by the specified properties of the foam generated

3.1.5

isocyanate component

liquid isocyanate product which is one of the components of the rigid foam spray system

3.1.6

polyol component

liquid polyhydroxyl product containing an expanding agent, catalysts and other additives which is one of the components of the rigid foam spray system

3.1.7

machine

equipment used to mix and spray the foam

3.1.8

mixing ratio

proportions of the components of the rigid foam spray system specified by the manufacturer to be sprayed to generate the rigid polyurethane or polyisocyanurate foam

Note 1 to entry: This can be expressed either as a weight or a volume ratio or both.

3.1.9

installation

process of spraying the mixture of the components onto the surface to be insulated

Note 1 to entry: The procedure is carried out by the application of successive rigid foam layers until the specified foam thickness is obtained.

3.1.10

declared installed insulation density

representative overall density for the installed insulation product (see 5.3)

3.1.11

declared installed insulation thickness

insulation thickness as installed by the installer (see 5.1)

3.1.12

declared installed aged thermal resistance

time average value of the thermal resistance of the installed insulation over 25 years (see 5.2)

3.1.13

protective layer

final layer added to the exposed surface of the installed foam, which may otherwise in its end-use application, be exposed to damage by UV radiation

3.2 Symbols and abbreviations

Symbols used in this standard:

R_D is the declared installed aged thermal resistance m^2K/W

d is the declared installed insulation thickness m

Abbreviations used in this standard:

PUR is Rigid PolyUrethane foam

PU is rigid polyurethane foam including PUR and PIR types

PIR is Rigid PolyIsocyanurate foam

4 Requirements

4.1 General

The installer shall use a PUR or PIR foam system that complies with EN 14315-1.

NOTE The range of properties exhibited by PUR products is very wide. The same is true for PIR products and these two ranges often overlap. Although not in every case, generally PIR products have a higher upper service temperature and can perform better in reaction to fire tests. In all cases, for both PIR and PUR products, their individual performance claimed by the manufacturer are described by the levels of properties obtained. Accordingly, therefore, all the declaration clauses will be completed using the term PU to include both PUR and PIR products (see 3.1.3).

4.2 Suitability of the building for the installation of the product

The installer shall inspect the building in accordance with manufacturer's technical information and any national rules, in order to determine whether it is suitable for application of the product (see Annex D).

5 In-situ measurements and calculations

5.1 Declared installed insulation thickness

The declared installed insulation thickness, d , shall be measured in accordance with the procedure given in Annex A. However, the value shall not be less than the minimum installed insulation thickness specified by the client or given in the manufacturer's technical information.

5.2 Declared installed aged thermal resistance, R_D

The declared installed aged thermal resistance R_D for the installed insulation shall be declared according to the performance chart given by the manufacturer in accordance with the procedure given in EN 14315-1.

NOTE 1 The correction of the values of thermal conductivity due to the influence of moisture and temperature can be calculated using the procedures given in EN ISO 10456.

NOTE 2 For calculating the thermal resistance of complete building elements involving the use of these products, the procedures given in EN ISO 6946 can be used.

5.3 Declared installed insulation density

The declared installed insulation density when determined by the methods given in Annex B shall not be less than the minimum specified by the client and comply with the manufacturer's technical information.

5.4 Foam quality checks carried out by the installer

The installer shall carry out those on site checks defined by the manufacturer, and check compliance with EN 14315-1 prior to commencing the application of the foam, generate test samples in accordance with either the procedures in Annex D of EN 14315-1:2013 and by any procedures required by the local rules of a Member State.

6 Guidelines for installation

National Practice, National Standards, National Regulations or Local Rules may exist, covering for example the spraying conditions and the mixing ratio. In the absence of national regulations, national standards or any local rules, the manufacturer's technical information shall be followed together with the procedure given in Annex E.

7 Installer's declaration

The installer shall declare to the customer that the work has been carried out in accordance with the requirements of this Part 2 of this standard using a foam system that complies with Part 1 of this standard.

The installer shall also state at least the following information:

- a) date of the installation;
- b) declared installed insulation thickness;
- c) declared installed aged thermal resistance according to 5.2;
- d) declared installed insulation density;
- e) surface area of the sprayed insulation product;
- f) for the installed product, the trade name, designation code of the foam system (complying with Part 1 of this standard, from which it has been generated);
- g) the number of the EC certificate of conformity.

NOTE Further information may be declared as in the examples given in Annex E.

Annex A (normative)

Method of the determination of the declared installed insulation thickness

Procedure

The installed thickness shall be checked with a 2 mm maximum diameter probe calibrated in mm or with non-destructive electronic devices.

For every 100 m² of sprayed surface, measurements of thickness shall be taken at ten locations on the sprayed surface. By visual judgement, five measurements shall be taken from the area of the apparent highest thickness and five measurements from the area of apparent lowest thickness with no measurements taken in the area up to 200 mm from either side or from any edge or corner. However, if the width of the spray areas is less than 450 mm, the measurement shall not be made in an area less than 100 mm from any edge or corner.

Calculate the average of the ten measurements in each case, and also the average of these averages, as the declared installed insulation thickness.

For installed insulation thicknesses ≥ 100 mm, no individual measurement shall be lower than the insulation thickness by more than 25 mm.

For installed insulation thicknesses < 100 mm, no individual measurement shall be lower than the installed insulation thickness by more than 25 % of the installed insulation thickness.

Annex B (normative)

Methods for the determination of the declared installed insulation density

B.1 Principle

The declared installed insulation density is obtained from representative samples from the product as installed.

B.2 Procedure

B.2.1 General

Either of the two following procedures shall be used to obtain the test samples from which the declared installed insulation density shall be determined: either the immersion method given in Annex C (only for products with closed cell contents equal to or greater than 90 % (CCC4) or the method given in EN 1602.

B.2.2 Destructive testing

Extract a representative test specimen from the installed product when starting the spray application and at the start of spraying on a new site.

B.2.3 Non-destructive testing

Prepare a representative sample each day before starting the spray application and at the start of spraying on a new site.

The sample shall be prepared using a representative substrate.

A release agent may be applied to the surface to be sprayed of the representative substrate.

Cut the representative test specimen from the sample such that skins are included.

Measure the density by the methods given in B.2.1.

B.3 Test report

The test report includes the following:

- Declared installed insulation density rounded to the nearest Kg/m^3 .
- Date of the test.
- Method used for the determination of the declared installed insulation density.
- Location/site details.

Annex C (normative)

Immersion method for the determination of the declared installed insulation density

C.1 Scope

When the test specimens are taken from the installed insulation foam and are consequently of an irregular form, the density shall be calculated according to the immersion method.

C.2 Principles

The determination of the density of a body is based on the measurement of the mass and the determination of its volume. When the body is of an irregular form for CCC4 products only, the volume shall be determined according to the immersion method.

C.3 Necessary equipment

C.3.1 Scale, precise to 0,2 g.

C.3.2 Tripod.

C.3.3 Test specimen clip.

C.3.4 Vessel.

C.3.5 Wire.

C.4 Products and reagents

C.4.1 Test specimen, weight not less than 10 g.

C.4.2 Water.

C.5 Procedure

Measure the mass of the test specimen, in grams.

The volume of the test specimen is measured with the following procedure:

Prepare a vessel on the scale containing water. With the test specimen installed in the clip, lower the test specimen completely into the water being careful not to touch the walls of the vessel (see Figure C.1). The change in weight is then recorded. This change in weight will be the volume of the test specimen on the basis that $1 \text{ g} = 1 \text{ cm}^3$.

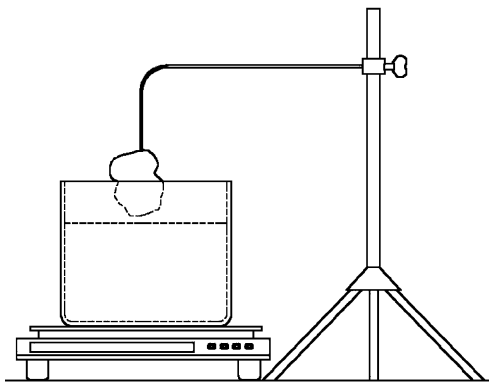

Figure C.1 — Example of an immersion apparatus

C.6 Results

Determine the declared installed insulation density, using the following expression:

Declared installed insulation density

$$(\text{Kg/m}^3) = (M / V) \times 1000 \quad (\text{C.1})$$

where

M is the mass of the test specimen in g.

V is the volume of the test specimen in cm^3 .

Annex D (normative)

Suitability of the building to receive the insulation product

D.1 Building

The installer shall ensure that the walls, ceilings, roofs and suspended ceilings are suitable to receive the sprayed insulation. This assessment shall take into account all aspects of the proposed installation.

In particular, the substrates to be sprayed shall be clean, dry and free of extraneous materials. Vapour barriers shall be provided if necessary.

D.2 Site survey

The site survey includes the following:

- Description of the building substrate to be insulated.
- Determination of the limits of the area to be insulated.
- Checking the existence of any dust, water or oils on the substrate likely to interfere with the adhesion of the sprayed foam.
- Checking the general condition of the substrate and its consistency.
- Checking the existence of any expansion joints or ventilation holes.
- Checking if the substrate is a metal surface that has been suitably protected from atmospheric corrosion by a suitable coating.

Annex E (normative)

Installation guidelines

E.1 General

The following installation procedure shall be followed for each separate installation or once a day, whichever is the more frequent.

E.2 Substrate preparation

Sprayed foam can be applied to any suitably prepared surface.

Before beginning the installation, the condition of the substrate shall be checked in case any dust or other contaminants need to be removed by washing down. If the substrate is contaminated by grease or oil, it shall be degreased. Where there is an adhesion problem on the substrate, a primer coating shall be applied before spraying to obtain good adhesion, for example metallic, plastic surfaces, or wet surfaces.

In any case and before proceeding to start to spray, it is necessary to carry out a small adhesion test on the substrate in order to check that good adhesion will be obtained.

In case of the existence of expansion joints that could cause breaks in the foam due to the movement of the support, these joints shall be covered with a non-adhesive plastic tape.

E.3 Substrate conditions

The substrate to which the foam is applied shall have a minimum temperature of +5 °C.

Porous surfaces shall not have a moisture content greater than 20 %. Non-porous substrates shall be checked to ensure that there is no surface condensation.

E.4 Spraying machine preparation

E.4.1 Preparation

Set the spraying machine to the output, the mixing ratio and the components delivery lines to the temperatures and pressures specified by the foam system supplier. This data shall be recorded.

E.4.2 Mixing ratio

Check that the mixing ratio is correct by measuring the output separately from the two component delivery lines.

For fixed output spraying machines, monthly confirmation of the mixing ratio shall be carried out; and for variable output spraying, daily confirmation shall be carried out.

The value of the mixing ratio shall not differ by more than 5 % in weight from the value indicated by the foam system supplier.

E.5 Spraying procedure

The spraying procedure shall consist of spraying on to the substrate the mixture of the components by means of the spraying machine, where this mixture expands and hardens forming the foam.

The foam shall be applied in passes such that the total thickness will be built up in discrete layers with average thicknesses according to the manufacturer's technical information.

E.6 Protection against UV radiation

Foam which is exposed to external atmosphere in the end-use application shall be protected against UV radiation, usually by the application of a protective layer (see. 3.1.13).

E.7 An example of a suitable declaration form which can be used by the installer

The installation:

Company name and address.....

Name of applicator.....

Trade Mark, Model and Serial Number of the Machine.....

The insulation product:

Trade name

Manufacturer.....

Product standard

Designation code

Number of the EC Certificate of Conformity.....

Free-rise density

Reaction to fire.....

Close cell content.....

The installation site:

Address

Type of installation.....

The installation:

Insulated area (m²)

Declared installed insulation density (kg/m³)

Type of substrate

Substrate temperature.....

Substrate moisture.....

Ambient temperature.....

Ambient moisture.....

Declared installed insulation thickness (mm)

Declared installed aged thermal resistance (m²·K/W)

Date of installation:

Installer signature:

Bibliography

- [1] EN ISO 6946, *Building components and building elements — Thermal resistance and thermal transmittance — Calculation method (ISO 6946)*
- [2] EN ISO 10456, *Building materials and products — Hygrothermal properties — Tabulated design values and procedures for determining declared and design thermal values (ISO 10456)*

British Standards Institution (BSI)

BSI is the national body responsible for preparing British Standards and other standards-related publications, information and services.

BSI is incorporated by Royal Charter. British Standards and other standardization products are published by BSI Standards Limited.

About us

We bring together business, industry, government, consumers, innovators and others to shape their combined experience and expertise into standards-based solutions.

The knowledge embodied in our standards has been carefully assembled in a dependable format and refined through our open consultation process. Organizations of all sizes and across all sectors choose standards to help them achieve their goals.

Information on standards

We can provide you with the knowledge that your organization needs to succeed. Find out more about British Standards by visiting our website at bsigroup.com/standards or contacting our Customer Services team or Knowledge Centre.

Buying standards

You can buy and download PDF versions of BSI publications, including British and adopted European and international standards, through our website at bsigroup.com/shop, where hard copies can also be purchased.

If you need international and foreign standards from other Standards Development Organizations, hard copies can be ordered from our Customer Services team.

Subscriptions

Our range of subscription services are designed to make using standards easier for you. For further information on our subscription products go to bsigroup.com/subscriptions.

With **British Standards Online (BSOL)** you'll have instant access to over 55,000 British and adopted European and international standards from your desktop. It's available 24/7 and is refreshed daily so you'll always be up to date.

You can keep in touch with standards developments and receive substantial discounts on the purchase price of standards, both in single copy and subscription format, by becoming a **BSI Subscribing Member**.

PLUS is an updating service exclusive to BSI Subscribing Members. You will automatically receive the latest hard copy of your standards when they're revised or replaced.

To find out more about becoming a BSI Subscribing Member and the benefits of membership, please visit bsigroup.com/shop.

With a **Multi-User Network Licence (MUNL)** you are able to host standards publications on your intranet. Licences can cover as few or as many users as you wish. With updates supplied as soon as they're available, you can be sure your documentation is current. For further information, email bsmusales@bsigroup.com.

BSI Group Headquarters

389 Chiswick High Road London W4 4AL UK

Revisions

Our British Standards and other publications are updated by amendment or revision.

We continually improve the quality of our products and services to benefit your business. If you find an inaccuracy or ambiguity within a British Standard or other BSI publication please inform the Knowledge Centre.

Copyright

All the data, software and documentation set out in all British Standards and other BSI publications are the property of and copyrighted by BSI, or some person or entity that owns copyright in the information used (such as the international standardization bodies) and has formally licensed such information to BSI for commercial publication and use. Except as permitted under the Copyright, Designs and Patents Act 1988 no extract may be reproduced, stored in a retrieval system or transmitted in any form or by any means – electronic, photocopying, recording or otherwise – without prior written permission from BSI. Details and advice can be obtained from the Copyright & Licensing Department.

Useful Contacts:

Customer Services

Tel: +44 845 086 9001

Email (orders): orders@bsigroup.com

Email (enquiries): cservices@bsigroup.com

Subscriptions

Tel: +44 845 086 9001

Email: subscriptions@bsigroup.com

Knowledge Centre

Tel: +44 20 8996 7004

Email: knowledgecentre@bsigroup.com

Copyright & Licensing

Tel: +44 20 8996 7070

Email: copyright@bsigroup.com



...making excellence a habit.™