



BSI Standards Publication

Thermal insulating products for buildings — In-situ formed sprayed rigid polyurethane (PUR) and polyisocyanurate (PIR) foam products

Part 1: Specification for the rigid foam
spray system before installation

National foreword

This British Standard is the UK implementation of EN 14315-1:2013.

The UK participation in its preparation was entrusted to Technical Committee PRI/72, Rigid cellular materials.

A list of organizations represented on this committee can be obtained on request to its secretary.

This publication does not purport to include all the necessary provisions of a contract. Users are responsible for its correct application.

© The British Standards Institution 2013.
Published by BSI Standards Limited 2013.

ISBN 978 0 580 53441 6

ICS 91.100.60

Compliance with a British Standard cannot confer immunity from legal obligations.

This British Standard was published under the authority of the Standards Policy and Strategy Committee on 31 January 2013.

Amendments issued since publication

Date	Text affected
------	---------------

ICS 91.100.60

English Version

Thermal insulating products for buildings - In-situ formed
sprayed rigid polyurethane (PUR) and polyisocyanurate (PIR)
foam products - Part 1: Specification for the rigid foam spray
system before installation

Produits isolants thermiques destinés aux applications du bâtiment - Produits en mousse rigide de polyuréthane (PUR) ou de polyisocyanurate (PIR) projetée, formés en place - Partie 1: Spécifications relatives aux systèmes de projection de mousse rigide avant mise en oeuvre

Wärmedämmstoffe für das Bauwesen - An der Verwendungsstelle hergestellter Wärmedämmstoff aus Polyurethan (PUR) - und Polyisocyanurat (PIR)-Spritzschaum - Teil 1: Spezifikation für das Schaumsystem vor dem Einbau

This European Standard was approved by CEN on 17 November 2012.

CEN members are bound to comply with the CEN/CENELEC Internal Regulations which stipulate the conditions for giving this European Standard the status of a national standard without any alteration. Up-to-date lists and bibliographical references concerning such national standards may be obtained on application to the CEN-CENELEC Management Centre or to any CEN member.

This European Standard exists in three official versions (English, French, German). A version in any other language made by translation under the responsibility of a CEN member into its own language and notified to the CEN-CENELEC Management Centre has the same status as the official versions.

CEN members are the national standards bodies of Austria, Belgium, Bulgaria, Croatia, Cyprus, Czech Republic, Denmark, Estonia, Finland, Former Yugoslav Republic of Macedonia, France, Germany, Greece, Hungary, Iceland, Ireland, Italy, Latvia, Lithuania, Luxembourg, Malta, Netherlands, Norway, Poland, Portugal, Romania, Slovakia, Slovenia, Spain, Sweden, Switzerland, Turkey and United Kingdom.



EUROPEAN COMMITTEE FOR STANDARDIZATION
COMITÉ EUROPÉEN DE NORMALISATION
EUROPÄISCHES KOMITEE FÜR NORMUNG

Management Centre: Avenue Marnix 17, B-1000 Brussels

Contents

Page

Foreword.....	4
1 Scope.....	5
2 Normative references.....	5
3 Terms, definitions, symbols and abbreviations.....	6
3.1 Terms and definitions	6
3.2 Symbols and abbreviations	8
4 Requirements	9
4.1 General	9
4.2 For all applications.....	9
4.3 Specific applications.....	12
5 Test methods.....	15
5.1 Sampling and test specimen preparation	15
5.2 Conditioning.....	15
5.3 Testing.....	16
6 Designation code	18
7 Evaluation of conformity.....	18
7.1 General	18
7.2 Initial type testing.....	19
7.3 Factory production control.....	19
8 Marking, labelling and technical information.....	19
8.1 Marking and labelling.....	19
8.2 Technical information	19
Annex A (normative) Determination of declared aged thermal conductivity and aged thermal resistance	21
A.1 Introduction	21
A.2 Input data.....	21
A.3 Declared values.....	21
Annex B (normative) Initial type testing (ITT) and Factory production control (FPC)	23
Annex C (normative) Determination of the aged values of thermal resistance and thermal conductivity.....	25
C.1 General	25
C.2 Sampling and test specimen preparation	25
C.3 Determination of the initial value of thermal conductivity	26
C.4 Determination of the accelerated aged value of thermal conductivity	27
C.5 Fixed increment procedure.....	29
C.6 Declaration of the aged values of thermal resistance and aged thermal conductivity	31
Annex D (normative) Preparation of the test sample	33
D.1 Principle.....	33
D.2 Procedure	33
Annex E (normative) Determination of the reaction profile and free-rise density.....	34
E.1 Introduction	34
E.2 Principle.....	34
E.3 Apparatus	34
E.4 Procedure	34
E.5 Free-rise density	35
Annex F (normative) Determination of substrate adhesion strength perpendicular to faces	36

F.1	Principle	36
F.2	Apparatus	36
F.3	Sample preparation and conditioning	36
F.4	Preparation of test specimens	36
F.5	Testing procedure	36
F.6	Presentation of results	36
Annex G	(normative) Testing for reaction to fire products	37
G.1	Scope	37
G.2	Product and installation parameters	37
G.3	Mounting and fixing	38
G.4	Field of application	40
Annex H	(normative) Testing for reaction to fire products in standardised assemblies simulating end-use application(s)	42
H.1	Scope	42
H.2	Product and installation parameters	42
H.3	Mounting and fixing	43
H.4	Field of application	47
Annex I	(informative) Example for the determination of the declared aged values of thermal conductivity and thermal resistance for a product	49
Annex J	(normative) Instructions for compiling thermal resistance performance charts	51
J.1	Introduction	51
J.2	General	51
J.3	Procedure for the manufacturer to create the performance charts	53
Annex ZA	(informative) Clauses of this European Standard addressing the provisions of the EU Construction Products Directive	57
Bibliography	64

Foreword

This document (EN 14315-1:2013) has been prepared by Technical Committee CEN/TC 88 “Thermal insulating materials and products”, the secretariat of which is held by DIN.

This European Standard shall be given the status of a national standard, either by publication of an identical text or by endorsement, at the latest by July 2013, and conflicting national standards shall be withdrawn at the latest by July 2013.

Attention is drawn to the possibility that some of the elements of this document may be the subject of patent rights. CEN [and/or CENELEC] shall not be held responsible for identifying any or all such patent rights.

This document has been prepared under a mandate given to CEN by the European Commission and the European Free Trade Association, and supports essential requirements of EU Directive(s).

For relationship with EU Directive(s), see informative Annex ZA, which is an integral part of this document.

This European Standard consists of two parts which form a package. The first part is the harmonised part satisfying the mandate and the CPD and is the basis for the CE marking covering the products, which are placed on the market. The second part, which is the non-harmonised part, covers the specification for the installed products. Both parts need to be used for the application of the insulation products in the end-use applications covered by EN 14315.

This European Standard is one of a series for mineral wool, expanded clay, expanded perlite, exfoliated vermiculite, polyurethane/polyisocyanurate, cellulose, bound expanded polystyrene and expanded polystyrene in-situ formed insulation products used in buildings, but this standard may be used in other areas where appropriate.

The reduction in energy used and emissions produced during the installed life of insulation products exceeds by far the energy used and emissions made during the production and disposal processes.

EN 14315, *Thermal insulating products for buildings — In-situ formed sprayed rigid polyurethane (PUR) and polyisocyanurate (PIR) foam products*, consists of the following parts:

- *Part 1: Specification for the rigid foam spray system before installation* (the present document)
- *Part 2: Specification for the installed insulation products*

According to the CEN/CENELEC Internal Regulations, the national standards organisations of the following countries are bound to implement this European Standard: Austria, Belgium, Bulgaria, Croatia, Cyprus, Czech Republic, Denmark, Estonia, Finland, Former Yugoslav Republic of Macedonia, France, Germany, Greece, Hungary, Iceland, Ireland, Italy, Latvia, Lithuania, Luxembourg, Malta, Netherlands, Norway, Poland, Portugal, Romania, Slovakia, Slovenia, Spain, Sweden, Switzerland, Turkey and the United Kingdom.

1 Scope

This European Standard specifies requirements for in-situ formed sprayed rigid polyurethane (PUR) and rigid polyisocyanurate (PIR) foam products when applied to walls, ceilings, roofs, suspended ceilings and floors.

This Part 1 of this European Standard is a specification for the rigid foam spray system before installation.

Part 1 of this European Standard describes the product characteristics and includes procedures for testing, marking and labelling and the rules for evaluation of conformity.

This European Standard does not specify the required levels of all properties to be achieved by a product to demonstrate fitness for purpose in a particular end-use application. The required levels are to be found in regulations or non-conflicting standards.

This European Standard does not cover factory made rigid polyurethane (PUR) or polyisocyanurate (PIR) foam insulation products or in-situ products intended to be used for the insulation of building equipment and industrial installations.

NOTE Foam products are either called flexible or rigid. The flexible products are used in upholstery and mattresses and are characterised by their ability to deflect, support and recover to their original thickness continually during their in-use phase. Those that are not flexible are termed rigid and do not possess these flexible characteristics. They are mostly used for thermal insulation purposes and vary widely in their compression strength values. Once the cell structure is crushed in a rigid foam, it does not recover its thickness fully. Some of these rigid foams are very low in density with very low compression strengths and are sometimes described “commercially” as “soft foams” or “semi-rigid” foams. This note has been included to clarify that all foams with such descriptions are covered by this standard’s use of the term rigid foam.

2 Normative references

The following documents, in whole or in part, are normatively referenced in this document and are indispensable for its application. For dated references, only the edition cited applies. For undated references, the latest edition of the referenced document (including any amendments) applies.

EN 312, *Particleboards — Specifications*

EN 508-1, *Roofing products from metal sheet — Specification for self-supporting products of steel, aluminium or stainless steel sheet — Part 1: Steel*

EN 520, *Gypsum plasterboards — Definitions, requirements and test methods*

EN 823, *Thermal insulating products for building applications — Determination of thickness*

EN 826, *Thermal insulating products for building applications — Determination of compression behaviour*

EN 1602, *Thermal insulating products for building applications — Determination of the apparent density*

EN 1604, *Thermal insulating products for building applications — Determination of dimensional stability under specified temperature and humidity conditions*

EN 1605, *Thermal insulating products for building applications — Determination of deformation under specified compressive load and temperature conditions*

EN 1606, *Thermal insulating products for building applications — Determination of compressive creep*

EN 1607:1996, *Thermal insulating products for building applications — Determination of tensile strength perpendicular to faces*

EN 1609, *Thermal insulating products for building applications — Determination of short term water absorption by partial immersion*

EN 12086, *Thermal insulating products for building applications — Determination of water vapour transmission properties*

EN 12667:2001, *Thermal performance of building materials and products — Determination of thermal resistance by means of guarded hot plate and heat flow meter methods — Products of high and medium thermal resistance*

EN 12939, *Thermal performance of building materials and products — Determination of thermal resistance by means of guarded hot plate and heat flow meter methods — Thick products of high and medium thermal resistance*

EN 13172:2012, *Thermal insulation products — Evaluation of conformity*

EN 13238, *Reaction to fire tests for building products — Conditioning procedures and general rules for selection of substrates*

EN 13501-1, *Fire classification of construction products and building elements — Part 1: Classification using test data from reaction to fire tests*

EN 13823:2010, *Reaction to fire tests for building products — Building products excluding floorings exposed to the thermal attack by a single burning item*

EN ISO 354, *Acoustics — Measurement of sound absorption in a reverberation room (ISO 354)*

EN ISO 1182, *Reaction to fire tests for products — Non-combustibility test (ISO 1182)*

EN ISO 1716, *Reaction to fire tests for products — Determination of the gross heat of combustion (calorific value) (ISO 1716)*

EN ISO 9229:2007, *Thermal insulation — Vocabulary (ISO 9229:2007)*

EN ISO 11654, *Acoustics — Sound absorbers for use in buildings — Rating of sound absorption (ISO 11654)*

EN ISO 11925-2:2010, *Reaction to fire tests — Ignitability of products subjected to direct impingement of flame — Single-flame source test (ISO 11925-2:2010)*

ISO 4590, *Rigid cellular plastics — Determination of the volume percentage of open cells and of closed cells*

3 Terms, definitions, symbols and abbreviations

For the purposes of this document, the terms and definitions given in EN ISO 9229:2007 and the following apply.

3.1 Terms and definitions

3.1.1

polyurethane foam PUR (in-situ formed products)

rigid cellular plastics insulation material or product with a structure based on polymers mainly of the polyurethane type

3.1.2

polyisocyanurate foam PIR (in-situ formed products)

rigid cellular plastics insulation material or product with a structure based on polymers mainly of the polyisocyanurate type

3.1.3

polyurethane foam PU

rigid cellular plastics insulation materials or products including both polymer types based mainly on polyurethane (PUR) or mainly on polyisocyanurate (PIR) groups

3.1.4

rigid foam spray system

kit of constituent components which when sprayed generates the rigid polyurethane (PUR) foam or the rigid polyisocyanurate (PIR) foam characterised by the specified properties of the foam generated

3.1.5

isocyanate component

liquid isocyanate product which is one of the components of the rigid foam spray system

3.1.6

polyol component

liquid polyhydroxyl product containing an expanding agent, catalysts and other additives which is one of the components of the rigid foam spray system

3.1.7

cream time

time which has elapsed between the time at which the stirring procedure for the mixed components was started and the moment when the foam is observed as starting to rise (usually measured in seconds)

3.1.8

gel time

time which has elapsed between the time at which the stirring procedure for the mixed components was started and the moment when, by means of a rod (or a match) applied into the surface of the foam, a polymeric string can be drawn from the foam surface (usually measured in seconds)

3.1.9

tack-free time

time which has elapsed between the time the stirring procedure for the mixed components was started and the moment when, by means of a rod (or a match) applied to the top surface of the foam, the top surface is established as no longer tacky (usually measured in seconds)

3.1.10

free-rise density

density of the unfaced cut test specimen taken from the reaction profile test sample (see E.5)

3.1.11

mixing ratio

proportions of the components of the rigid foam spray system specified by the manufacturer to be sprayed to generate the rigid polyurethane or polyisocyanurate foam

Note 1 to entry: This can be expressed either as a weight or a volume ratio or both.

3.1.12

production batch

amount of a component produced discontinuously in a single period of time of a rigid foam system

3.1.13

level

given value which is the upper or lower limit of a requirement, where the level is given by the declared value of the characteristic concerned

3.1.14

class

combination of two levels of the same property between which the performance shall fall, where the level is given by the declared value of the characteristic concerned

3.2 Symbols and abbreviations

3.2.1 Symbols used in this standard

α_p	is the practical sound absorption coefficient	-
α_w	is the weighted sound absorption coefficient	-
d_N	is the nominal thickness of the product	mm
$\Delta\epsilon_l$	is the relative change in length	%
$\Delta\epsilon_b$	is the relative change in width	%
$\Delta\epsilon_d$	is the relative change in thickness	%
ϵ_{ct}	is the compressive creep	%
ϵ_t	is the total thickness reduction	%
k	is a factor related to the number of test results available	-
k_a	is a factor related to the number of aged test results	-
k_i	is a factor related to the number of initial test results	-
$\lambda_{90/90}$	is the 90 % fractile with a confidence level of 90 % for the thermal conductivity	W/(m·K)
λ_D	is the declared thermal conductivity (aged)	W/(m·K)
λ_i	is one test result of thermal conductivity	W/(m·K)
λ_{mean}	is the mean thermal conductivity	W/(m·K)
$\lambda_{mean,a}$	is the mean thermal conductivity of aged values	W/(m·K)
$\lambda_{mean,i}$	is the mean thermal conductivity of initial values	W/(m·K)
$\Delta\lambda_a$	is the ageing increment from measured aged values of thermal conductivity	W/(m·K)
$\Delta\lambda_f$	is the fixed ageing increment	W/(m·K)
μ	is the water vapour diffusion resistance factor	-
n	is the number of test results	-
$R_{90/90}$	is the 90 % fractile with a confidence level of 90 % for the thermal resistance	m ² K/W
R_D	is the declared thermal resistance	m ² K/W
R_i	is one test result of thermal resistance	m ² K/W
R_{mean}	is the mean thermal resistance	m ² K/W
s_λ	is the estimate of the standard deviation of the thermal conductivity	W/(m·K)
$s_{\lambda,a}$	is the estimate of the standard deviation of the aged values of thermal conductivity	W/(m·K)
$s_{\lambda,i}$	is the estimate of the standard deviation of the initial values of thermal conductivity	W/(m·K)
s_R	is the estimate of the standard deviation of the values of thickness	m
σ_{10}	is the compressive stress at 10 % deformation	kPa
σ_a	is the substrate adhesion strength perpendicular to faces	kPa
σ_c	is the declared stress for determination of compressive creep	kPa
σ_m	is the compressive strength	kPa
W_p	is the short term water absorption by partial immersion	kg/m ²

3.2.2 Designation codes used in this standard

AP(d)	is the symbol for the declared level of practical sound absorption coefficient with d for the thickness or the range of thicknesses, expressed in millimetres, in which the declared value is valid
-------	---

AW(d)	is the symbol for the declared level of weighted sound absorption coefficient with d for the thickness or the range of thicknesses, expressed in millimetres, in which the declared value is valid
A	is the symbol for the declared level of substrate adhesion strength
CC(i_1, i_2, y) σ_c	is the symbol for the declared level for compressive creep with i_1 for the total reduction in thickness level, i_2 for the compressive creep level, y for the corresponding time in years and σ_c for the declared compression extrapolated deformation and y for the corresponding time in years
CCC	is the symbol for the declared level for closed cell content
CS(10\Y)	is the symbol for the declared value for compressive stress or strength
CT	is the symbol for the declared cream time
DLT(i)5	is the symbol for the declared level for deformation under load and temperature at
DS (TH)	is the symbol for the declared level for dimensional stability under specified temperature and humidity
FRB	is the symbol for the declared beaker free-rise density
FRC	is the symbol for the declared core free-rise density
GT	is the symbol for the declared gel time
MU	is the symbol for the declared water vapour diffusion resistance factor
TFT	is the symbol for the declared tack-free time
W	is the symbol for the declared short term water absorption by partial immersion

3.2.3 Abbreviations used in this standard:

PIR is	R igid P olyIsocyanurate Foam
PU is	rigid polyurethane foam including PUR and PIR types
PUR is	R igid P oly U rethane Foam
ITT is	I nitial T ype T est

4 Requirements

4.1 General

The foam properties shall be assessed in accordance with Clause 5. To conform with this standard, foam systems shall meet the requirements of 4.2 and 4.3 as appropriate.

NOTE The range of properties exhibited by PUR products is very wide. The same is true for PIR products and these two ranges often overlap. Although not in every case, generally PIR products have a higher upper service temperature and can perform better in reaction to fire tests. In all cases, for both PIR and PUR products, their individual performance claimed by the manufacturer are described by the levels of properties obtained. Accordingly, therefore, all the declaration clauses will be completed using the term PU to include both PUR and PIR products (see 3.1.3).

One test result for a foam property is the average of the measured values on the number of test specimens given in Table 7.

4.2 For all applications

4.2.1 Thickness measurements

Unless otherwise specified by the test method, in all the other test methods involving the measurement of thickness, this shall be carried out using the method given in EN 823.

4.2.2 Thermal resistance and thermal conductivity

Thermal resistance and thermal conductivity shall be based upon measurements carried out in accordance with EN 12667 or EN 12939 for thick products.

The thermal resistance and thermal conductivity (both the initial and the aged values) shall be determined in accordance with Annex A, Annex C and 5.3.2 and the aged values declared by the manufacturer according to the following:

- the reference mean temperature shall be 10 °C;
- the measured values shall be expressed with three significant figures;
- the thermal resistance, R_D , shall always be declared. The thermal conductivity, λ_D , shall be declared wherever this is possible;
- the declared thermal resistance, R_D , and the thermal conductivity, λ_D , shall be given as limit values representing at least 90 % of the production, determined with a confidence level of 90 %;
- the value of thermal conductivity, $\lambda_{90/90}$, shall be rounded upwards to the nearest 0,001 W/(m·K) and declared as λ_D in levels with steps of 0,001 W/(m·K);
- the declared thermal resistance, R_D , shall be calculated from the nominal thickness, d_N , and the corresponding thermal conductivity, $\lambda_{90/90}$ unless measured directly;
- the value of thermal resistance, $R_{90/90}$, when calculated from the nominal thickness, d_N , and the corresponding thermal conductivity, $\lambda_{90/90}$; shall be rounded downwards to the nearest 0,05 m²·K/W, and declared as R_D in levels with steps of 0,05 m²·K/W (see Note);

An example of the determination of the declared aged values of thermal conductivity and thermal resistance is given in Annex I.

NOTE The declaration of the declared installed aged thermal resistance for an installed sprayed rigid PU foam is made in Part 2 of this standard (EN 14315-2) by the installer.

4.2.3 Reaction to fire of the products

4.2.3.1 General

The reaction to fire classification of the products placed on the market shall be determined in accordance with EN 13501-1 and using data obtained from tests carried out according to procedures EN ISO 11925-2 and EN 13823 and utilising test specimens conforming to 4.2.3.2 and mounting and fixing procedures in accordance with 4.2.3.3.

The PUR or PIR product may be qualified as one for which the Reaction to Fire classification is not susceptible to change during production of the system, provided that it can be demonstrated (for example with a production control system) that the characteristics responsible for change are within a range where no change of the declared classification for the product occurs.

4.2.3.2 Test specimens

4.2.3.2.1 EN ISO 11925-2

Cut six test specimens 250⁰₋₁ mm long and 90⁰₋₁ mm wide and using the product thickness up to a maximum of 60⁰₋₁ mm thick including the internal facing in accordance with 5.2 of EN ISO 11925-2:2010 from a sample prepared in accordance with Annex D and complying with the requirements of G.3.1.1.

4.2.3.2.2 EN 13823

Prepare five specimens in accordance with G.3.2.1.

4.2.3.3 Mounting and fixing procedures

4.2.3.3.1 EN ISO 11925-2

Test specimens prepared in accordance with 4.2.3.2.1 shall be mounted in the EN ISO 11925-2 test apparatus as specified in G.3.1.

4.2.3.3.2 EN 13823

Test specimens prepared in accordance with 4.2.3.2.2 shall be mounted so that the inner face of the test specimen which is typical of the end use application is in contact with the flame source. In all other respects, the products shall be mounted as specified in G.3.2.

4.2.3.4 Procedures

4.2.3.4.1 EN ISO 11925-2

Apply the test flame to the natural skin of the test specimen (as specified in G.3.1.1).

4.2.3.4.2 EN 13823

Expose the internal surface of the test specimen to the test flame (see G.3.2.1 and G.3.2.2).

4.2.4 Reaction profile and free-rise density

The appropriate values for the spray foam system shall be stated, having been determined in accordance with the procedures given in Annex E.

4.2.5 Durability characteristics

4.2.5.1 General

The appropriate durability characteristics have been considered and are covered in 4.2.5.2, 4.2.5.3 and 4.2.5.4.

4.2.5.2 Durability of reaction to fire against ageing/degradation

The reaction to fire performance of PU products does not decrease with time, in the applications covered by this standard.

4.2.5.3 Durability of thermal resistance against ageing/degradation

This is covered by 4.2.3, 4.3.12 and Annex C which contains an ageing procedure used to determine the values of the declared thermal resistance.

4.2.5.4 Durability of compression strength against ageing/degradation

The compression strength of PU products remains constant with time if there is no air diffusing into the cells (ageing). If air diffusion is characteristic of the product then the compression strength will increase with time. The higher the closed cells level, the higher the increase of the compression strength with the time, i.e. this increase will be the highest with level CCC4 and least with level CCC1.

4.2.6 Closed cell content

The closed cell content shall be determined using the ISO 4590 method and classified as shown in Table 1.

Table 1 — Classes for closed cell content

Class	Closed cell content
CCC1	< 20 %
CCC2	20 % to 80 %
CCC3	> 80 % to 89 %
CCC4	≥ 90 %

4.3 Specific applications

4.3.1 General

If there is no intended requirement for a property described in 4.3, for a product in the end-use application, then the property need not be determined and declared by the manufacturer.

4.3.2 Water vapour transmission

Water vapour transmission properties shall be determined in accordance with EN 12086, Method A (23 °C, 0/50 % R.H.). The water vapour resistance shall be declared as the water vapour resistance factor, μ , under the symbol MU. No test result shall be lower than the declared value.

4.3.3 Short-term water absorption by partial immersion

The short-term water absorption by partial immersion, W_p , in kg/m^2 , shall be determined using EN 1609, Method B and shall be declared in kg/m^2 . No test result shall be higher than the declared value.

4.3.4 Compressive stress or compressive strength

Compressive stress at 10 % deformation, σ_{10} , or the compressive strength, σ_m , shall be determined in accordance with EN 826. No test result for either the compressive stress at 10 % deformation, σ_{10} , or the compressive strength, σ_m , whichever is the smaller, shall be lower than the value, given in Table 2, for the declared level.

Table 2 — Levels for compressive stress or compressive strength

Level	Requirement kPa
CS(10\Y)100	≥ 100
CS(10\Y)150	≥ 150
CS(10\Y)200	≥ 200
CS(10\Y)300	≥ 300
CS(10\Y)400	≥ 400
CS(10\Y)500	≥ 500

NOTE For PU products, the effects of pedestrian or stationary traffic can be assessed by means of determination of the compressive stress or compressive strength in accordance with EN 826.

4.3.5 Compressive creep

Compressive creep, ε_{ct} , and total thickness reduction, ε_t , shall be determined after at least 122 days of testing at a declared compressive stress, σ_c , given in steps of at least 1 kPa and the results extrapolated 30 times, corresponding to 10 years, to obtain the declared levels in accordance with EN 1606. Compressive creep shall be declared in levels, i_2 , and the total thickness reduction shall be declared in levels i_1 , with steps of 0,5 % at the declared stress. No test result shall exceed the declared levels at the declared stress.

NOTE 1 Examples for declaration of levels for compressive creep are given in Table 3.

Table 3 — Levels for compressive creep

Level	Test time	Extrapolation time	Declared stress	Requirement
	days	years	kPa	%
CC($i_1/i_2/10$) σ_c	122	10	σ_c	i_1, i_2
CC($i_1/i_2/25$) σ_c	304	25	σ_c	i_1, i_2
CC($i_1/i_2/50$) σ_c	608	50	σ_c	i_1, i_2

NOTE 2 Referring to the designation code CC($i_1/i_2/y$) σ_c , according to Clause 6, a declared level CC(3/2/25)40, for example, indicates a value not exceeding 2 % for compressive creep and 3 % for total thickness reduction after extrapolation at 25 years (i.e. 30 times 304 days of testing) under a declared stress of 40 kPa.

4.3.6 Sound absorption

The sound absorption coefficient shall be determined in accordance with EN ISO 354. The sound absorption characteristics shall be calculated according to EN ISO 11654 with the values for α_p (practical sound absorption coefficient) at the following frequencies: 125 Hz, 250 Hz, 500 Hz, 1 000 Hz, 2 000 Hz and 4 000 Hz and the single number value for α_w (weighted sound absorption coefficient).

α_p and α_w shall be rounded to the nearest 0,05 (α_p larger than 1 shall be expressed as $\alpha_p = 1$) and declared in levels with steps of 0,05. No test result (α_p and α_w) shall be lower than the declared level.

If the sound absorption is declared, the thickness or the range of thicknesses, in which the declared value is valid, shall be also indicated.

NOTE In any case, the dependence of the sound absorption with the thickness in rigid foam spray systems is very low and only relevant for those with low closed cell contents (CCC1).

4.3.7 Dangerous substances

National regulations on dangerous substances may require verification and declaration on release, and sometimes content, when construction products covered by this standard are placed on those markets.

In the absence of European harmonised test methods, verification and declaration on release/content should be done taking into account national provisions in the place of use.

NOTE An informative database covering European and national provisions on dangerous substances is available at the Construction web site on EUROPA accessed through: <http://ec.europa.eu/enterprise/construction/cpd-ds/>

4.3.8 Substrate adhesion strength perpendicular to faces

This property shall be measured using the procedure given in Annex F. For CCC1 products with closed cell content less than 20 %, the adhesion of the foam to the substrate, σ_a , shall be such that it exceeds the cohesive strength of the foam. For all other products, the bond strength shall not be less than 20 kPa and declared according to the levels given in Table 4.

Table 4 — Levels of substrate adhesion strength perpendicular to faces

Level	Requirement kPa
A1	≥ 20
A2	≥ 50
A3	≥ 100

4.3.9 Reaction to fire of products in standardised assemblies simulating end-use applications

4.3.9.1 General

The reaction to fire classification taking into account the end-use application shall be determined in accordance with Annex H using EN 13501-1 and using data obtained from tests carried out according to the procedures in EN ISO 11925-2 and H.3.1 and EN 13823 and using test specimens conforming to H.3.2.1 and mounting and fixing procedures in accordance with H.3.2.8.

NOTE The ignitability procedure using EN ISO 11925-2 in Annex H is identical to the procedure given under G.3.1 and therefore need not be repeated. Accordingly, this clause contains only information relevant to testing carried out according to EN 13823 in Annex H.

4.3.9.2 Test specimens for the EN 13823 test

Prepare five test specimens in accordance with H.3.2.1.

4.3.9.3 Mounting and fixing procedure

Test specimens prepared in accordance with 4.3.9.2 shall be mounted and fixed according to H.3.2.8.

4.3.10 Continuous glowing combustion

Where subject to regulations, the manufacturer shall declare the continuous glowing combustion of the product. In the absence of a European test method, the compliance with the requirement shall be made on the basis of an existing national test method.

NOTE A European test method is under development and the standard will be amended when this is available.

4.3.11 Deformation under specified compressive load and temperature conditions

Deformation under specified compressive load and temperature conditions shall be determined in accordance with EN 1605. The relative change in thickness, $\Delta\varepsilon_d$, shall not exceed the values, given in Table 5, for the declared level.

Table 5 – Levels for deformation under specified compressive load and temperature conditions

Level	Test conditions	Requirement %
DLT(1)5	Load: 20 kPa Temperature: (80 ± 1) °C Time: (48 ± 1) h	≤ 5
DLT(2)5	Load: 40 kPa Temperature: (70 ± 1) °C Time: (168 ± 1) h	≤ 5
DLT(3)5	Load: 80 kPa Temperature: (60 ± 1) °C Time: (168 ± 1) h	≤ 5

4.3.12 Dimensional stability under specified temperature and humidity conditions

Dimensional stability under specified temperature and humidity conditions shall be determined in accordance with EN 1604. The tests, each on different sets of specimens, shall be carried out for (48 ± 1) h at both (-20 ± 3) °C and at (70 ± 2) °C and a relative humidity of (90 ± 5) %.

The relative changes in length, $\Delta\epsilon_l$, with $\Delta\epsilon_b$ and thickness $\Delta\epsilon_d$, shall not exceed the values given in Table 6 for the labelled level.

Table 6 — Levels for dimensional stability under specified temperature and humidity conditions

Test condition	Dimensional changes		Level DS(TH)			
			1	2	3	4
1 (70 ± 2) °C and (90 ± 5) % r.h.	$\Delta\epsilon_l$	%	≤ 15	≤ 9	≤ 6	≤ 4
	$\Delta\epsilon_d$	%	≤ 10	≤ 5	≤ 2	≤ 1
2 (-20 ± 3) °C	$\Delta\epsilon_l$	%	≤ 3	≤ 2	≤ 2	≤ 2
	$\Delta\epsilon_d$	%	≤ 3	≤ 1	≤ 0,5	≤ 0,5

5 Test methods

5.1 Sampling and test specimen preparation

Prepare a sample of thickness not less than 50 mm in accordance with the procedure given in Annex D. Select from this the test specimens required to evaluate the characteristics given in 4.2 and 4.3 in accordance with the details given in Table 7, with the exception of reaction to fire performance (4.2.3) and (4.3.9) where special test specimens specified in Annexes G and H shall be used.

5.2 Conditioning

No special conditioning of the test specimens shall be used unless otherwise specified in the test standards. In case of dispute, the test specimens shall be stored at (23 ± 2) °C and (50 ± 5) % relative humidity for at least 16 h prior to testing.

5.3 Testing

5.3.1 General

Table 7 gives the dimensions of the test specimens, the minimum number of test specimens required to get one test result and any specific conditions which are necessary.

5.3.2 Thermal resistance and thermal conductivity

Thermal resistance and thermal conductivity shall be determined in accordance with EN 12667 or EN 12939 for thick products and under the following conditions:

- at a mean reference temperature of $(10 \pm 0,3)$ °C;
- after conditioning in accordance with 5.2;
- after preparation of the test specimen in accordance with C.2.

Thermal resistance and thermal conductivity may also be measured at mean temperatures other than 10 °C, providing that the accuracy of the relationship between temperature and thermal properties is sufficiently documented.

Thermal resistance and thermal conductivity shall be measured directly at a specimen thickness of 30 mm and if required on other selected thicknesses of the product to enable the manufacturer to produce performance charts in accordance with the procedure given in Annex J providing that:

- the product is of similar chemical and physical characteristics and is produced on the same production unit; and
- it can be demonstrated that the initial thermal conductivity does not vary more than 2 % over the range of thicknesses where the calculation is applied.

Table 7 — Test methods, specimens and conditions

Clause		Test method	Test specimen length and width/thickness	Number to get one test result	Specific conditions
No	Title				
4.2.1	Thickness measurements	EN 823	Unless otherwise specified see EN 823	See 4.2.1 of the standard	
4.2.2	Thermal resistance – Thermal conductivity	EN 12667 EN 12939	See Annex C and 5.3.2	1	See Annex C
4.2.3	Reaction to fire of the products	EN 13501-1	See EN 13501-1		
4.2.4	Reaction profile and free-rise density	Annex E		2	
4.2.6	Closed cell content	ISO 4590	See ISO 4590	3 sets	
4.3.2	Water vapour transmission	EN 12086	See EN 12086 $\leq 500 \text{ cm}^2 \times 50$ $> 500 \text{ cm}^2 \times 50$	5 3	
4.3.3	Short-term water absorption by partial immersion	EN 1609	$200 \times 200 \times 50$	4	
4.3.4	Compressive stress or compressive strength	EN 826	$d \leq 50$: 50×50 $50 < d \leq 100$: 100×100	3	^b
4.3.5	Compressive creep	EN 1606	$d \leq 50$: 50×50 $d > 50$: 100×100	2	
4.3.6	Sound absorption	EN ISO 354	min. 10 m^2	1	To be reported
4.3.7	Release of dangerous substances	-	-	-	^a
4.3.8	Substrate adhesion strength perpendicular to faces	Annex F	$100 \times 100 \times 20$ or $50 \times 50 \times 20$	3 5	^c
4.3.9	Reaction to fire of products in standardised assemblies simulating end-use applications	EN 13501-1	See EN 13501-1		
4.3.10	Continuous glowing combustion	-	-	-	^a
4.3.11	Deformation under specified compressive load and temperature conditions	EN 1605	$d < 50$: 50×50 $d > 50$: 100×100	3	
4.3.12	Dimensional stability under specified temperature and humidity conditions	EN 1604	$200 \times 200 \times 30$	3	
^a Not yet available. ^b Each individual value shall meet the requirement. ^c No individual value may be more than 25 % below the average value which corresponds to the fixed level.					

6 Designation code

A designation code for the product shall be given by the manufacturer. The following shall be included except where there is no requirement for a property described in 4.3.

—	PU	
—	This European Standard number	
—	Dimensional stability under specified temperature and humidity conditions	DS(TH)i
—	Closed cell content	CCCi
—	Reaction profile and free-rise density	
—	— cream time	CTi (*)
—	— gel time	GTi (*)
—	— tack free time	TFTi (*)
—	— free-rise density by the core (or beaker) methods	FRCi(*) (or FRB)i (*)
—	Short term water absorption by partial immersion	Wi
—	Compressive stress or compressive strength	CS(10\Y)I
—	Compressive creep	CC(i ₁ ,i ₂ ,y)σ _c
—	Deformation under specified compressive load and temperature conditions	DLT(i)5
—	Practical sound absorption coefficient	APi(d)
—	Weighted sound absorption coefficient	AWi(d)
—	Water vapour diffusion resistance factor	MUi
—	Substrate adhesion strength perpendicular to faces	Ai
—	Declared thermal conductivity (aged)	see performance charts in Annex J

where “i” shall be used to indicate the relevant level.

Inside (*) replace the * by the temperature of measurement in °C.

The designation code for a PUR/PIR product is illustrated by the following example:

EXAMPLE PU EN14315-1-DS(TH)2-CCC1-CT5(20)-GT15(20)-TFT25(20)-FRC30(20)-CS(Y)3-CC(2%,25)40-A1

7 Evaluation of conformity

7.1 General

The manufacturer or his authorised representative established in the EEA shall be responsible for the conformity of his products with the requirements of this European Standard. The evaluation of conformity shall be carried out in accordance with EN 13172 and shall be demonstrated by:

- initial type testing (ITT);
- factory production control by the manufacturer, including product assessment and tests on samples taken at the factory.

If a manufacturer decides to group his products it shall be done in accordance with EN 13172.

7.2 Initial type testing

ITT shall be carried out according to the principles of EN 13172, in accordance with Annex B.

7.3 Factory production control

Factory production control characteristics shall be made for the characteristics in Annex B. The minimum frequencies of test in the factory production control shall be in accordance with Annex B. When indirect testing is used, the correlation to direct testing shall be established in accordance with EN 13172. For thermal conductivity, only the initial (unaged) values shall be checked.

8 Marking, labelling and technical information

8.1 Marking and labelling

Foam systems complying with this standard shall be clearly marked either on the invoice or a label with at least the following information:

- product name or other identifying characteristic;
- name or identifying mark and address of the manufacturer or his authorised representative established in the EEA;
- year of manufacture (the last two digits);
- time of production or traceability code;
- reaction to fire;
- performance charts detailing the product thermal resistance appropriate to the use of the product (see Annex J);
- designation code (as given in Clause 6).

NOTE For CE marking see Annex ZA.

8.2 Technical information

The foam system supplier shall provide technical information. This technical information shall consist of at least the following:

- product name or other identifying characteristic;
- name or identifying mark and address of the manufacturer or his authorised representative established in the EEA;
- intended application(s);
- suitable substrates;

- a range of component temperatures and spraying conditions; at least the range of ambient temperature, range of substrate temperature, maximum ambient humidity, maximum substrate moisture content and range of layer thickness;
- storage conditions;
- shelf life;
- mixing ratio;
- additives needed;
- foam system specifications;
- foam properties;
- handling instructions.

Annex A (normative)

Determination of declared aged thermal conductivity and aged thermal resistance

A.1 Introduction

It is the responsibility of the manufacturer to determine the declared aged values of thermal resistance and thermal conductivity. He will have to demonstrate conformity of the product to its declared values. The declared values of aged thermal resistance and aged thermal conductivity of a product are the expected values of these properties during an economically reasonable working life under normal conditions, assessed through measured data at reference conditions.

A.2 Input data

The manufacturer shall have at least ten test results for the aged thermal resistance or aged thermal conductivity, obtained from internal or external direct measurements in order to calculate the declared values. The direct aged thermal resistance or aged thermal conductivity measurements shall be carried out at regular intervals spread over a period of the last 12 months. If less than ten test results are available, that period may be extended until ten test results are obtained, but with a maximum period of three years, within which the product and production conditions have not changed significantly. For new products, the ten aged thermal resistance or aged thermal conductivity tests shall be carried out spread over a minimum of three batches.

The declared values shall be calculated according to the methods given in A.3.

A.3 Declared values

A.3.1 General

The derivation of the declared values from the calculated values shall use the rules given in 4.2.1 which include the rounding conditions.

A.3.2 Case where thermal resistance and thermal conductivity are declared

The declared aged values shall be derived from the calculated values which are determined using Formulae A.1, A.2 and A.3.

$$\lambda_{90/90} = \lambda_{\text{mean},a} + k \cdot s_{\lambda a} \quad (\text{A.1})$$

$$s_{\lambda a} = \sqrt{\frac{\sum_{i=1}^n (\lambda_i - \lambda_{\text{mean},a})^2}{n-1}} \quad (\text{A.2})$$

$$R_{90/90} = d_N / \lambda_{90/90} \quad (\text{A.3})$$

A.3.3 Case where thermal resistance alone is declared

The declared value shall be derived from the calculated value which is determined using Formulae A.4 and A.5.

$$R_{90/90} = R_{\text{mean}} - k \cdot s_R \quad (\text{A.4})$$

$$s_R = \sqrt{\frac{\sum_{i=1}^n (R_i - R_{\text{mean}})^2}{n-1}} \quad (\text{A.5})$$

Table A.1 — Values for k for one sided 90 % tolerance interval with a confidence level of 90 %

Number of test results	10	11	12	13	14	15	16	17	18	19	20	22
k	2,07	2,01	1,97	1,93	1,90	1,87	1,84	1,82	1,80	1,78	1,77	1,74
Number of test results	24	25	30	35	40	45	50	100	300	500	2 000	∞
k	1,71	1,70	1,66	1,62	1,60	1,58	1,56	1,47	1,39	1,36	1,32	1,282

NOTE For other numbers of test results ISO 12491 will be used. Linear interpolation is acceptable.

Annex B
(normative)

Initial type testing (ITT) and Factory production control (FPC)

Table B.1 — Minimum product testing frequencies

Clause		ITT ^{a, b, d} Minimum number of tests	FPC ^a Minimum testing frequency
No.	Title		
4.2.2	Thermal resistance and thermal conductivity	A minimum of 10 tests are needed statistically with a minimum of 4 from the ITT	Every batch tested ^e
4.2.3	Reaction to fire of products	1	See Table B.2
4.2.4	Reaction profile and free rise density	4	1 per batch
4.2.6	Closed cell content	4	4 per year or if less than 4 batches per year 1 per batch
4.3.2	Water vapour transmission	4	1 per 5 years
4.3.3	Short term water absorption by partial immersion	4	1 per 5 years
4.3.4	Compressive stress or compressive strength	4	4 per year or if less than 4 batches per year 1 per batch
4.3.5	Compressive creep	4	1 per 10 years
4.3.6	Sound absorption	4	1 per 5 years
4.3.7	Release of dangerous substances	c	c
4.3.8	Substrate adhesion strength perpendicular to faces	4	1 per 5 years
4.3.9	Reaction to fire of products in standardised assemblies simulating end-use applications	1	1 per 5 years
4.3.10	Continuous glowing combustion	c	c
4.3.11	Deformation under specified compressive load and temperature conditions	4	1 per 5 years
4.3.12	Dimension stability under specified temperature and humidity conditions	4	1 per 5 years
Annex C	Accelerated aged value of thermal conductivity in accordance with C.4.2	4	1 per 2 years
	Acceleration test in accordance with C.4.4	4	
	Diffusion tightness of facing in accordance with C.5.1	4	
	Normality test in accordance with C.5.2	4	

Table B.1 (continued)

<p>^a In line with EN 13172, the minimum testing frequencies, expressed in test results, shall be understood as the minimum for each batch. In addition to the testing frequencies given above, testing of relevant properties of the product shall be repeated when changed or modifications are made that are likely to affect the conformity of the product.</p> <p>^b ITT, see EN 13172 and is only relevant when properties are declared.</p> <p>^c Frequencies are not given. When drafting this standard no European harmonised test methods were available.</p> <p>^d Minimum number of tests may be reduced according to EN 13172. For initial type testing of long term thermal and mechanical properties, test results of similar products produced at different plants will be recognised until testing for a new plant is complete.</p> <p>^e Although all batches will be tested either by initial testing or indirect testing, the testing regime will be as follows: If the number of batches ≤ 4 – Every batch shall be tested by direct and indirect testing; If the number of batches > 4 – Every batch shall be tested by indirect testing and at least four batches by direct testing. The frequency of producing batches varies with the product producer but the method of control can also vary with the manufacturer, with most favouring close control of the composition of the products.</p>

Table B.2 — Minimum product testing frequencies for the reaction to fire characteristics

Clause No.	Minimum testing frequency ^a				
	Title	Direct testing ^b		Indirect testing ^{c, d}	
4.2.3	Reaction to fire Euroclass	Test method	Frequency	Test method	Frequency
	B C D	EN 13823 and EN ISO 11925-2	1 per 2 years and indirect testing 1 per week or 1 per 2 years and indirect testing	Check of raw material formulation and free-rise density	1 per batch
	E	EN ISO 11925-2	4 per year or 1 per 2 years and indirect testing	Check of raw material formulation and free-rise density	1 per batch
	F	—	—	—	—

- ^a The minimum testing frequencies shall be understood for a product for each production batch under stable conditions. In addition to the testing frequencies given above, testing of relevant properties of the product shall be repeated when changes or modifications are made that are likely to affect the conformity of the product.
- ^b Direct testing may be conducted either by third party or by the manufacturer.
- ^c Indirect testing is only possible in the case of products falling within the system 1 for attestation for conformity of reaction to fire or by having a notified body verifying the direct testing.
- ^d Indirect testing may be either on the product or of its components.

Annex C (normative)

Determination of the aged values of thermal resistance and thermal conductivity

C.1 General

This annex describes methods which are used to take account of the ageing effect, which when it occurs is due to changes in the cell gas composition with time. These methods give a prediction of the time averaged' aged value over 25 years.

The determination of the aged value shall be made either by the direct measurement method (accelerated ageing procedure, C.4) or by a combination of the normality test and the calculation method (fixed increment procedure, C.5). For both methods the sampling and test specimen preparation procedure shall be as described in C.2.

NOTE See Figure C.1 for a flow chart of the alternative ageing procedures.

The ageing methods given in C.4 and C.5 of this standard were designed primarily for PUR/PIR products with closed cell contents greater than or equal to 90 %, produced by using high molecular weight blowing agents such as hydrofluorocarbons (namely: HFC 134a, 245fa, 227ea, 365mfc), which substantially stay in the products cells for time periods well in excess of those required for a reasonable economic life. These blowing agents are therefore called 'permanent'. They can be used mixed together with each other and with carbon dioxide (CO₂). CO₂ is a 'non-permanent' blowing agent, which may readily diffuse out of the product. Ageing of the thermal properties of PUR/PIR products is therefore predominantly caused by the inward diffusion of air into the product cells and outward diffusion of CO₂, if diffusion tight facings do not prevent both.

For products with closed cell content less than 90 %, namely those in classes CCC1, CCC2 and CCC3, the fixed increment procedure in C.5 cannot be applied and therefore, the only methods that can be used for these products are the ones given in C.4.1, C.4.2 and C.4.3.

PUR/PIR products blown only with CO₂ are also covered by these ageing methods.

For mixtures of permanent blowing agents, the following procedures shall be followed:

- If the accelerated ageing procedure of C.4 is used, the safety increment in accordance with Table C.1 for that blowing agent in the mixture with the highest value shall be used.
- If the fixed increment procedure of C.5 is used, the result from the normality test will give the decision, which increment shall be taken. If the test result is below the required limit value for a particular blowing agent in the mixture, the increment in accordance with Table C.2 for this blowing agent shall be taken to determine the aged value of thermal conductivity.

If new blowing agents are shown to be 'permanent types' (meaning that they have diffusion coefficients similar to the established values for hydrofluorocarbons), the ageing methods defined in this annex can be used. New limit values for the fixed increment procedure (C.5) and different safety increments for the accelerated ageing procedure (C.4) may be required.

C.2 Sampling and test specimen preparation

Prepare a product test sample including any product facings as indicated in Annex D and such that the area dimensions of the product test sample shall not be less than those specified in Table A.1 of EN 12667:2001 which correspond to the product thickness, or shall be equal to the maximum product dimensions.

Condition the product test sample at (23 ± 3) °C and (50 ± 10) % relative humidity for at least 16 h before cutting the test specimen.

Cut the test specimen from the central area of the product test sample. The test specimens shall conform to those specified in Table A.1 of EN 12667:2001. Any facings shall be left in position provided they do not interfere with the thermal resistance measurements.

C.3 Determination of the initial value of thermal conductivity

The initial value of the thermal conductivity shall be derived from the measurement of the thermal resistance made between one to eight days after preparation.

Prepare the test specimen for thermal conductivity measurements in accordance with C.2.

Measure the thermal conductivity of the test specimen in accordance with EN 12667, EN 12939 and 5.3.2 of this standard.

Calculate and report the initial value of thermal conductivity to the nearest 0,000 1 W/(m·K).

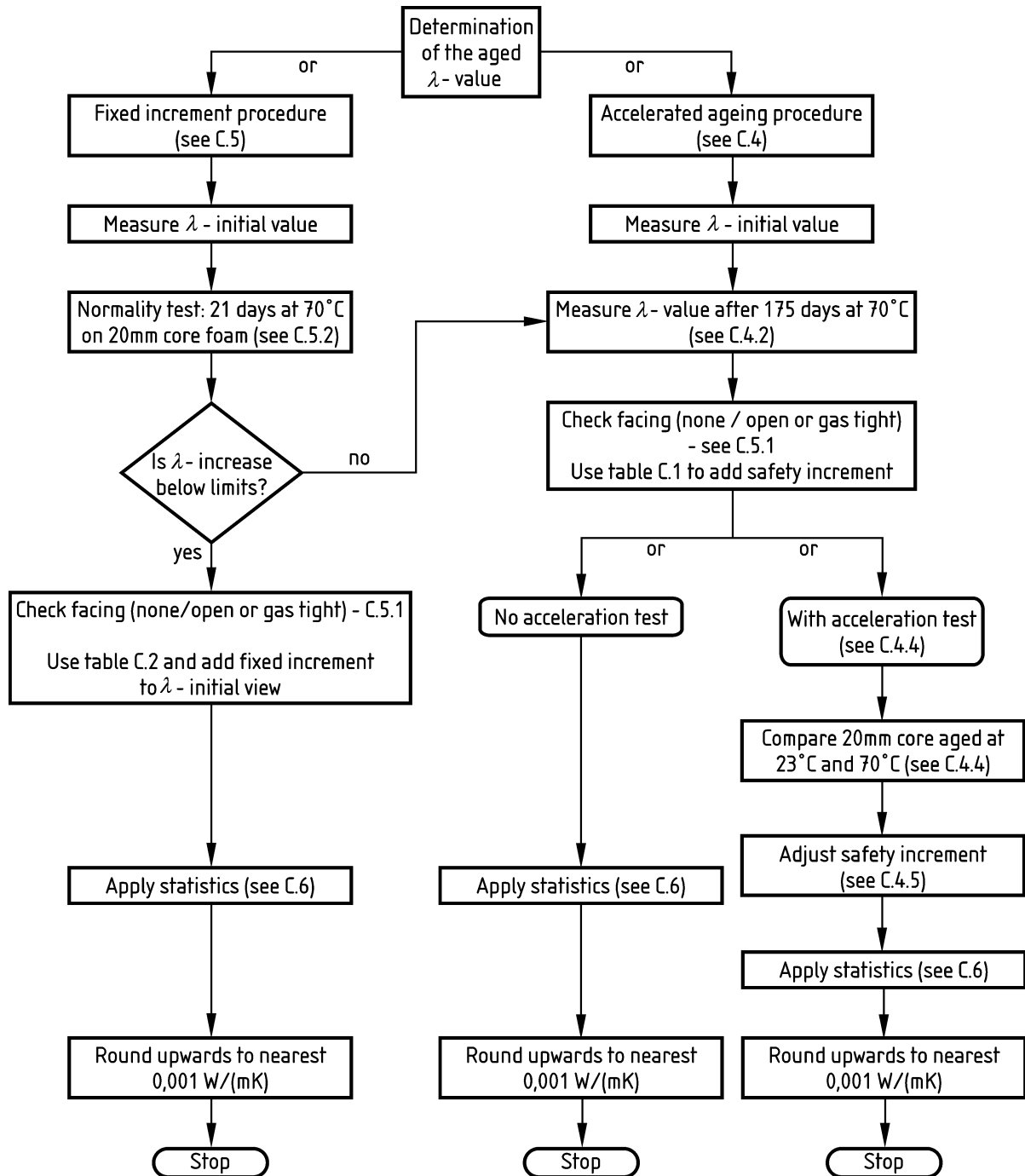

Figure C.1 — Flow chart of the alternative ageing procedures

C.4 Determination of the accelerated aged value of thermal conductivity

C.4.1 Procedure

The accelerated aged value of thermal conductivity shall be determined according to the following procedure:

- measure the accelerated aged value in accordance with C.4.2;
- add safety increment in accordance with C.4.3.

For diffusion open products it is allowed to carry out an acceleration test in accordance with C.4.4. Depending on the outcome of this acceleration test the safety increments of C.4.3 may be reduced in accordance with C.4.5.

C.4.2 Measurement of the accelerated aged value of thermal conductivity

The full product, including any facings, shall be tested. The area dimensions of the product test sample shall not be less than those specified in Table A.1 of EN 12667:2001 which correspond to the product thickness, or shall be equal to the product dimensions. For products with any diffusion tight facings, the maximum size of the product test sample shall be 800 mm × 800 mm.

The measured accelerated aged value of thermal conductivity shall be derived from the aged thermal resistance obtained after subjecting the product test sample to the accelerated ageing treatment.

This ageing treatment shall begin not earlier than one day and preferably not later than 50 days after preparing the test sample.

Store the product test sample at $(70 \pm 2) ^\circ\text{C}$ for (175 ± 5) days.

Then prepare the test specimen for thermal resistance measurement in accordance with C.2.

Measure the thermal resistance of the test specimens in accordance with EN 12667, EN 12939 and 5.3.2 of this standard.

Calculate and report the measured accelerated aged thermal conductivity value to the nearest 0,000 1 W/(m·K).

C.4.3 Addition of the safety increments (to be used with the accelerated ageing procedure only)

The value obtained under C.4.2 shall be increased with the safety increments as shown in Table C.1.

Table C.1 — Safety increments to be added to the measured accelerated aged value of thermal conductivity

Type of foam / facing	Blowing agent technology ^a	Safety increment in W/(m·K) for products with nominal thickness $d_N \leq 80$ mm	Safety increment in W/(m·K) for products with nominal thickness $d_N > 80$ mm
Cut foam without facings	HFC 245fa, 365mfc and 227ea	0,001 0	0,002 0
	HFC 134a	0,001 5	0,002 5
Faced with diffusion open facings	HFC 245fa, 365mfc and 227ea	0,001 0	0,001 5
	HFC 134a	0,001 5	0,002 0
Faced with diffusion tight facings ^b	HFC 134a, 245fa, 365mfc and 227ea	0,001 0	0,001 0

^a Safety increments for 100 % CO₂ blown products will be determined when sufficient information is available.
^b See C.5.1 for the definition of diffusion tight facings.

When requested, the manufacturer shall state the type of blowing agent used for the product.

Report the value to the nearest 0,000 1 W/(m·K). This value shall be used to determine the aged value of thermal conductivity, if no acceleration test data provides additional information (see C.4.4 and C.4.5).

C.4.4 Acceleration test (optional and for diffusion open products only, in combination with the accelerated ageing procedure)

Select a product test sample (one to eight days after preparation) and condition it for 16 h at (23 ± 3) °C and (50 ± 10) % relative humidity.

Cut two test specimens adjacent to each other of minimum dimensions 200 mm length and width $\times 20_0^{+2}$ mm thickness from the central area of the product test sample.

Determine the initial values of thermal conductivity of the two test specimens in accordance with C.3. The determined initial values of thermal conductivity shall not differ by more than 0,000 5 W/(m·K). In case of larger differences, new test specimens shall be sampled.

Store one test specimen at (70 ± 2) °C and the other test specimen at (23 ± 3) °C for such a time that the increase of the value of thermal conductivity has reached in both cases 0,003 W/(m·K) to 0,004 W/(m·K). Determine at least six values of thermal conductivity for each specimen within this range of thermal conductivity increase.

If the test specimen is reconditioned at room temperature for measurement of the value of thermal conductivity between subsequent accelerated ageing treatment at 70 °C, the time of conditioning shall be between 1 h to 2 h. The actual time of accelerated ageing at 70 °C shall be recorded.

Make plots of the values of thermal conductivity with time for ageing at 70 °C and at 23 °C and shift the time axis with a factor such that the two curves overlap. The time shift factor used to ensure best overlap of the curves is the acceleration factor. This factor shall be reported to the first decimal digit.

C.4.5 Determination of the accelerated aged value of thermal conductivity considering the acceleration factor (optional method and for diffusion open products only, in combination with the accelerated ageing procedure)

If a manufacturer chooses to carry out the acceleration test given in C.4.4 then the thermal conductivity determined for a product in C.4.3 may be amended as follows:

- if an acceleration factor of greater than 12 has been found the appropriate safety increment derived from Table C.1 shall be removed;
- if an acceleration factor of 8 to 12 inclusive has been found the value of thermal conductivity obtained in C.4.3 shall be reduced by 0,001 W/(m·K);
- in all other cases the value from C.4.3 shall remain unchanged.

Report the aged value of thermal conductivity to the nearest 0,000 1 W/(m·K).

C.5 Fixed increment procedure

C.5.1 Conditions

The fixed increment procedure described below shall only be used if:

- the product has fulfilled the requirements of the normality test given in C.5.2, except for CO₂ blown only products;
- CO₂ blown only products have a closed cell content, determined according to ISO 4590, of not less than 90 %;

- the product contains any of the blowing agents such as hydrofluorocarbons or a mixture of these with CO₂, or only CO₂;
- for products where installed so that it can be considered as having diffusion tight facings, these facings shall consist of a metal sheet with thickness not less than 50 µm or the facings shall show an equivalent performance. Faced products, which do not show an increase of the thermal conductivity of more than 0,001 W/(m·K) when tested for (175 ± 5) days at (70 ± 2) °C are considered to be covered with diffusion tight facings (maximum size of the sample 800 mm × 800 mm and maximum thickness 50 mm).

NOTE The diffusion tight property of a facing can also be proven, if the oxygen diffusion level is less than 4,5 ml per 24 h per m² when measured at 20 °C in accordance with ASTM 3985.

- the dimensions of rectangular products which have diffusion tight facings are not less than 600 mm × 800 mm.

For products with diffusion tight facings which have smaller dimensions than these limit values, either the procedure given in C.4 should be followed or the fixed increments for diffusion open facings given in Table C.2 should be used.

C.5.2 Normality test

Products blown with 'permanent' blowing agents shall fulfil the requirements of the following procedure:

- select a product test sample (one to eight days after manufacture) and condition it for 16 h at (23 ± 3) °C and (50 ± 10) % relative humidity;
- cut a test specimen of minimum dimensions 200 mm length and width × 20 (+2/-0) mm thickness from the central area of the product test sample;
- determine the initial value of thermal conductivity of the test specimen in accordance with C.3;
- store the test specimen at (70 ± 2) °C for (21 ± 1) days;
- after reconditioning for 16 h at (23 ± 3) °C and (50 ± 10) % relative humidity, determine the aged value of thermal conductivity of the test specimen in accordance with EN 12667 and EN 12939 and 5.3.2.

The difference between the aged and the initial values of thermal conductivity shall not be more than 0,006 0 W/(m·K) for 245fa, 227ea, 365mfc blown products and 0,007 5 W/(m·K) for 134a blown products.

If the difference is more than the values stated herein, the fixed increment method cannot be used and the aged thermal conductivity shall be obtained in accordance with C.4.

C.5.3 Calculation of the aged value of thermal conductivity

The aged value of thermal conductivity shall be determined by adding fixed increments to the initial value of thermal conductivity.

Determine the initial value of thermal conductivity in accordance with C.3.

Add the relevant increment given in Table C.2 to the initial value.

Report the calculated aged value of thermal conductivity to the nearest 0,000 1 W/(m·K).

Table C.2 — Increments for calculating the aged value of thermal conductivity

Blowing agent	Increment						
	Type of facing						
	None or diffusion open			One face diffusion tight			Both faces diffusion tight
	Nominal thickness						
	$d_N < 80$ mm	$80 \text{ mm} \leq d_N < 120$ mm	$d_N \geq 120$ mm	$d_N < 40$ mm	$40 \text{ mm} \leq d_N < 60$ mm	$d_N \geq 60$ mm	
HFCs 245fa, 227ea and 365mfc	0,006 0	0,004 8	0,003 8	0,006 0	0,004 8	0,003 8	0,001 5
HFC 134a	0,007 5	0,006 5	0,005 5	0,007 5	0,006 5	0,005 5	0,002 5
100 %CO ₂	0,010 0	0,010 0	0,010 0	0,010 0	0,010 0	0,010 0	0,006 0

When requested, the manufacturer shall state the type of blowing agent used for the product.

C.6 Declaration of the aged values of thermal resistance and aged thermal conductivity

C.6.1 General

The statistical variation as required in Annex A for the declaration of thermal resistance and thermal conductivity shall be calculated using either the initial or the aged values of thermal conductivity.

The initial values shall be determined in accordance with C.3 and the aged values in accordance with C.4 or C.5.

C.6.2 Product grouping

The manufacturer shall declare either

- separate thermal values for each single product and each single thickness and then determine the $\lambda_{90/90}$ value on each thickness for each product

or

- a thermal value for a product group including all or a range of thicknesses using the $\lambda_{90/90}$ value of this product group for the corresponding thickness range. Separate product groups shall be established for products without facing or diffusion open facings, for products with one diffusion tight facing and for products with two diffusion tight facings.

The manufacturer shall decide whether to create groups and the size of the groups. The determined thermal values of thin, medium and thick products shall be included in the statistics of a product group which covers all thicknesses or a range of thicknesses.

A minimum of ten initial or aged values shall be determined for each product group.

C.6.3 Initial values of thermal conductivity used to calculate the $\lambda_{90/90}$ value

$$\lambda_{90/90} = \lambda_{\text{mean},i} + k_i \cdot s_{\lambda,i} + \Delta\lambda_a \quad (\text{C.1})$$

or

$$\lambda_{90/90} = \lambda_{\text{mean},i} + k_i \cdot s_{\lambda,i} + \Delta\lambda_f \quad (\text{C.2})$$

$$R_{90/90} = d_N / \lambda_{90/90} \quad (\text{C.3})$$

where $\lambda_{\text{mean},i}$, k_i and $s_{\lambda,i}$, are calculated from the measured initial values of thermal conductivity in accordance with Annex A.

The ageing increment, $\Delta\lambda_a$, is determined as mean value of the thermal conductivity increase from measurements of two specimens by taking the difference between the measured aged value in accordance with C.4 and the measured initial value in accordance with C.3. The two specimens shall be taken from the same product, which is identified as the worst-case in a product group (e.g. the thinnest product).

The fixed ageing increment, $\Delta\lambda_f$, is the increment in accordance with C.5. For a product group, the fixed ageing increment of the worst-case product within the group shall be taken.

C.6.4 Aged values of thermal conductivity used to calculate the $\lambda_{90/90}$ value

$$\lambda_{90/90} = \lambda_{\text{mean},a} + k_a \cdot s_{\lambda,a} \quad (\text{C.4})$$

$$R_{90/90} = d_N / \lambda_{90/90} \quad (\text{C.5})$$

where $\lambda_{\text{mean},a}$, k_a and $s_{\lambda,a}$ are calculated from the measured aged values of thermal conductivity in accordance with Annex A.

Annex D **(normative)**

Preparation of the test sample

D.1 Principle

To prepare a sprayed foam test sample which is indicative of the method of use of the foam.

D.2 Procedure

Prepare a flat sheet not less than 1 000 mm x 700 mm. Apply a release agent if necessary. Spray the foam onto the horizontal sheet in accordance with the manufacturer's recommendations to give a sample not less than 50 mm thick. It shall contain at least one bond line between separately sprayed layers. After curing for not less than 16 h, remove the flat sheet from the test sample and cut at least 50 mm from all the edges to produce a test sample with the specified dimensions.

For thermal conductivity purposes, consideration should be given to the conditions pertaining in the end-use application. For example, if, when installed, the sprayed product will be applied to a diffusion tight facing with or without a diffusion tight covering then the thermal conductivity test sample should simulate the appropriate conditions, i.e. for both facings or surfaces consideration should be given as to whether the surface or facings will be open or diffusion tight and the sample prepared accordingly.

NOTE Normal application of sprayed foam uses a technique of building up layer upon layer of foam. For this reason the sample used for testing will include at least one inter laminar bond line between two layers. Occasionally in some applications the foam is applied in a single layer and for these the test sample need not include a bond line.

Annex E (normative)

Determination of the reaction profile and free-rise density

E.1 Introduction

This method is used to measure the reactivity and the beaker free-rise density of polyurethane or polyisocyanurate systems.

E.2 Principle

The polyol and isocyanate components of the foam system are mixed according to the manufacturer's recommendations to produce a particular small-scale laboratory foam which allows the determination of the reaction profile characteristics and free-rise density.

E.3 Apparatus

E.3.1 Motorised stirrer with a speed between 1 500 rev/min and 3 500 rev/min.

E.3.2 Weighing scales, to give an accuracy of 0,1 g.

E.3.3 Stopwatch, accurate to 0,5 s.

E.3.4 Paper or plastic beakers 0,3 l to 1 l capacity.

E.3.5 Thermometer, accurate to 0,5 °C.

E.4 Procedure

E.4.1 Pre-treatment of polyol component

Insert into the 1 l beaker (E.3.4), more of the polyol component than will be subsequently required to create the test foam. Condition the components at $(20 \pm 1) ^\circ\text{C}$ or in accordance with the manufacturer's technical information.

E.4.2 Making the foam

Weigh the amount polyol component specified (3.1.6) by the manufacturer into a beaker between 0,3 and 0,8 l capacity and add the specified amount of the isocyanate component. Stir immediately using the motorised stirrer (E.3.1) equal to half the expected cream time or in accordance with the manufacturer's recommendations. If required, pour the contents into a beaker between 0,5 and 1 l capacity and subsequently determine the cream time (3.1.7), gel time (3.1.8) and tack-free time (3.1.9).

E.4.3 Presentation of reaction profile data

These shall be presented with the following symbols followed in each case by the appropriate value in seconds and the temperature of measurement in °C. Precise conditions used to obtain these results shall be declared (refer to E.4).

CT (*) = cream time (in seconds), e.g. CT5(20)

GT (*) = gel time (in seconds), e.g. GT15(20)

TFT (*) - tack free time (in seconds), e.g. TFT25(20)

E.5 Free-rise density

E.5.1 General

The free-rise density shall be determined by either the core free-rise density method given in E.5.2 or the beaker free-rise density method given in E.5.3, according to the manufacturer's recommendation.

E.5.2 Core free-rise density

Cut a test specimen measuring 50 mm × 50 mm × 100 mm centrally from the foam sample created in the 1 l beaker, and measure the core free-rise density according to EN 1602.

E.5.3 Beaker free-rise density

For the determination of this value, cut off the foam that stands above the rim of the beaker. Take the quotient between the weight of the foam contained in the beaker and its volume to obtain the beaker free-rise density.

E.5.4 Presentation of free-rise density result

The free-rise density shall be presented as either the core free-rise density (FRC) (see E.5.2) or the beaker free-rise density (FRB) (see E.5.3) as appropriate followed by the appropriate free-rise density value in kg/m³. Precise conditions used to obtain these results shall be declared (refer to E.3 and E.4)

Annex F (normative)

Determination of substrate adhesion strength perpendicular to faces

F.1 Principle

This test is used to determine the adhesion of a PUR or PIR foam to a substrate, whereby either the adhesion strength of the bond between the foam and the substrate or the tensile cohesion strength of the foam is determined.

F.2 Apparatus

F.2.1 Fibre cement board substrate with dimensions larger than 300 mm × 300 mm.

F.2.2 Adhesive with an adhesion strength higher than the expected adhesion strength or the tensile cohesion strength of the foam.

F.2.3 Saw capable of cutting the substrate.

F.2.4 Tensile strength testing machine.

F.3 Sample preparation and conditioning

Condition the substrate (F.2) at a temperature of (20 ± 2) °C. Spray the foam onto the substrate in accordance with the manufacturer's recommendations to create a sample with a foam thickness not less than 30 mm. Condition the sample at (20 ± 2) °C and (50 ± 5) % R.H. for at least for 24 h.

F.4 Preparation of test specimens

Cut from the sample five test specimens 50 mm × 50 mm or 100 mm × 100 mm and reduce their foam thickness to (20 ± 2) mm.

F.5 Testing procedure

Using the adhesive (F.2.2), fix the test pieces to the faces of the tensile strength testing machine (F.2.4) so that the substrate is fixed onto one plate and the foam to the other. For each test specimen, follow the procedure described in Clause 7 of EN 1607:1996, recording the force when the sample breaks and noting whether the break occurs at the bond or in the foam. In both cases present the results as σ_a .

F.6 Presentation of results

Present the substrate adhesion strength perpendicular to faces as the mean value, σ_a' with a statement whether this is calculated from the bond strength failure or the cohesive failure of the foam.

- Substrate adhesion strength perpendicular to faces, σ_a , (in kPa);
- Breakage area (bond between foam and substrate or $w_{t_{\text{min}}}$ the foam).

Annex G (normative)

Testing for reaction to fire products

G.1 Scope

This annex gives basic rules for reaction to fire testing of products as placed on the market (product itself) including instructions for mounting and fixing, taking into account the product tested in isolation and not related to any end-use application and instructions for the field of application of the test results.

The following is related to 4.2.3 in the main body of the product standard.

G.2 Product and installation parameters

The test specimens shall be stored for at least six hours at (23 ± 5) °C. In case of dispute, they shall be stored at (23 ± 2) °C and (50 ± 5) % RH for 14 days.

Tables G.1 and G.2 give the parameters, that have to be taken into account when determining a product's reaction to fire performance and the field of application of the test results.

Table G.1 — Product parameters

Product parameter	EN ISO 1182 (Euroclass A1 and A2)	EN ISO 1716 (Euroclass A1 and A2)	EN 13823 (Euroclass A1 to D)	EN ISO 11925-2 (Euroclass B to E)
Thickness			X	X
Density	X		X	X
Type of product	X	X	X	X

NOTE Ageing or washing procedures are not applicable for the test specimens.

Table G.2 — Installation parameters

Installation parameter	EN 13823	EN ISO 11925-2
Exposure to thermal attack	X	X
Substrate	X	—
Air gaps/cavities	X	—
Joints/edges	—	—
Size and positioning of test specimen	X	—
Product orientation and geometry	—	—
Fixing of the test specimen	X	—

G.3 Mounting and fixing

G.3.1 Ignitability (EN ISO 11925-2)

G.3.1.1 Exposure to thermal attack

The product shall be tested directly exposed to the thermal attack.

The test specimen is submitted to direct flame exposure only on the natural skin. If only one face is exposed to fire in the works, that exposed face shall be tested.

G.3.1.2 Substrate

The test specimens, cut from the product test sample including their natural skin, shall be mounted in the test apparatus without a substrate.

G.3.2 Single Burning Item [SBI] (EN 13823)

G.3.2.1 Preparation of the test specimens

A test specimen shall be prepared by spraying onto the internal face of an L-shaped substrate which is prepared by adding externally at least five L-shaped steel brackets to the back of the substrate as shown in Figure G.1.

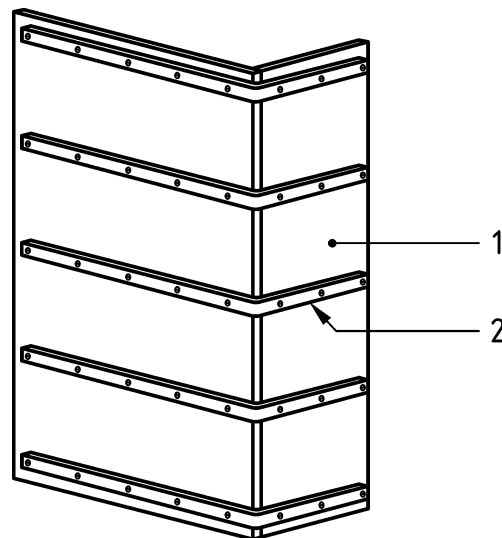

Key

- 1 substrate
- 2 steel brackets (width 30 mm, thickness 5 mm)

Figure G.1 — Preparation of the test specimen: external surface of the substrate

G.3.2.2 Exposure to thermal attack

The product shall be tested directly exposed to the thermal attack.

G.3.2.3 Substrate

The type of the substrate is defined in EN 13238. The general substrate to be used to test the product as placed on the market is made of calcium silicate. Gypsum plaster board and wooden particle board substrates such as defined in EN 13238 are permitted to be used instead. For A1 classification, a calcium silicate substrate is compulsory.

The test conditions and field of application of the classification shall be given in the declaration of conformity, in the classification report and are requested to be included in the manufacturer's technical literature.

G.3.2.4 Air gaps/cavities

Air gaps/cavities are not considered relevant for the reaction to fire behaviour of the product.

The test specimen (product itself) shall be mounted in the test apparatus without an air gap/cavity (neither between the product and substrate nor between substrate and backing board), except for the small space needed to accommodate the test specimen brackets (see Figure G.2).

G.3.2.5 Size and positioning of test specimen

The size of the test specimens is given in EN 13823:2010, 5.1. Positioning of the test specimens shall meet the following specification:

The maximum thickness of the test specimen including the substrate that can be installed in the SBI is 200 mm.

The test specimen shall be positioned as shown in Figure G.2.

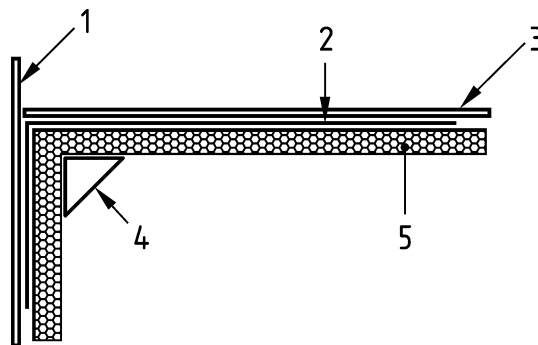

Key

- 1 backing boards
- 2 brackets
- 3 substrate
- 4 burner
- 5 test specimen natural skin surface

Figure G.2 — Installation of the test specimen (top view)

G.3.2.6 Fixing of the test specimen

The specimen with its substrate shall be fixed in the test apparatus by clamping and maintained between the backing boards and the U profile at the bottom part of the frame and the calcium silicate support at the top of the frame (see Figure G.3).

If necessary, the natural skin surface may be removed in places to create a flatter surface so that the test specimen will fit snugly against the U-profile section at the base of the apparatus adjacent to the burner. It may be necessary for example to remove sufficient foam internally at the corner to again allow a snug fit of the test specimen at the corner.

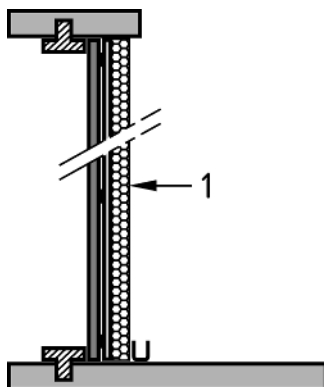

Key

1 test specimen

Figure G.3 — Principle for mounting the test specimen by clamping (cross section)

G.4 Field of application

The manufacturer is responsible for the grouping of his products following the rules described in EN 13172 and this standard. The validity of the test results and the field of application for a product group is determined by the product parameters and the installation parameters with the requirements given in Tables G.3 and G.4.

Table G.3 — Product parameters

Product parameter	Validity of test results			
	EN ISO 1182 Not relevant	EN ISO 1716 Not relevant	EN 13823 (SBI)	EN ISO 11925-2 (Ignitability)
Thickness			Test results are valid for equal or lower thickness.	
			Test results on a 180 mm thickness are also valid for higher thickness.	Test results on 60 mm thickness are also valid for higher thickness.
Density			Product density $\pm 15\%$	
Type of product, e.g. PUR or PIR			For the tested type only	

Table G.4 — Installation parameters

Installation parameter	Validity of test results	
	EN 13823 (SBI)	EN ISO 11925-2 (Ignitability)
Exposure to thermal attack	Test result is valid for product as placed on the market	See G.3.1.1
Substrate	The standard wooden particle board substrate represents wood and all A1 and A2 substrates. The standard gypsum plaster board represents all A1 and A2 substrates.	Not relevant
Air gaps/cavities	Test result valid for product applied with and without an air gap.	Not relevant
Size and positioning of test specimen	Test result is valid for all product sizes.	Not relevant
Fixing of test specimen	Test result is valid for all product fixings.	Not relevant

Annex H (normative)

Testing for reaction to fire products in standardised assemblies simulating end-use application(s)

H.1 Scope

This annex gives basic rules for an additional reaction to fire testing of the products in standardised assemblies simulating end-use applications and provides instructions for mounting and fixing and for the field of application of the test results. These are described in this annex by the term “standard test configuration of assemblies”.

In this annex, the term “standard test configuration of assemblies” is used.

The following is related to 4.3.9 of the product standard.

This annex gives the manufacturer the opportunity to give a complementary and optional declaration (where required) on reaction to fire for a standardised end-use application/assembled system including the insulation product.

The Euroclass classification of the product as placed on the market shall always be declared (see Annex G).

H.2 Product and installation parameters

Tables H.1 and H.2 give the parameters that have to be taken into account when determining the reaction to fire performance of standardised assemblies simulating end-use applications (assembled systems) including the thermal insulation product and the field of application of the test results.

The test specimens shall be stored for at least six hours at (23 ± 5) °C. In case of dispute, they shall be stored at (23 ± 2) °C and (50 ± 5) % RH for 14 days.

Table H.1 — Thermal insulation product parameters

Product parameter	EN ISO 1182 (Euroclass A1 and A2)	EN ISO 1716 (Euroclass A1 and A2)	EN 13823 (Euroclass A1 to D)	EN ISO 11925-2 (Euroclass B to E)
All products				
Thickness			X	X
Density	X		X	X
Type of product	X	X	X	X

NOTE Ageing or washing procedures are not applicable for the test specimens.

Table H.2 — Installation parameters

Installation parameter	EN 13823	EN ISO 11925-2
Exposure to thermal attack	X	X
Standardised surface products	X	-
Substrate	X	-
Air gaps/cavities	X	-
Joints/edges of the insulation product	X	-
Joints/edges of the surface product	X	-
Size and positioning of the insulation product	X	-
Product orientation and geometry	X	X
Fixing of the insulation product to the substrate	X	-
Fixing of the insulation product to the surface product	X	-

H.3 Mounting and fixing

H.3.1 Ignitability (EN ISO 11925-2)

H.3.1.1 Exposure to thermal attack

The thermal insulation product shall be tested directly exposed to the thermal attack. The test specimen is submitted to direct flame exposure on the natural skin. If only one face is exposed to fire in the works, that exposed face shall be tested.

If in the end-use application a surface product is subsequently to be bonded to the natural skin or placed in front of the sprayed product, then this test shall not be carried out.

H.3.1.2 Substrate

The test specimens, cut from the product test sample including their natural skin, shall be mounted in the test apparatus without a substrate.

H.3.2 Single Burning Item [SBI] (EN 13823)

H.3.2.1 Preparation of the test specimens

For products with surface products, if any, subsequently bonded to the natural skin or placed in front of the natural skin in the end-use application, a test specimen shall be prepared by spraying onto the internal face of an L-shaped substrate (see Figure H.1) which is prepared by adding externally at least five L-shaped steel brackets to the back of the substrate as shown in Figure H.1. Before testing, bond in place or place in front of the test specimen any surface product.

For test products in which the end-use application requires the surface product to be directly bonded to the sprayed product during its formation, spray the foam product directly onto the back of the surface product already prepared in an L-shape with a suitable internal bracket simulating the joint cover plate used in the end-use application.

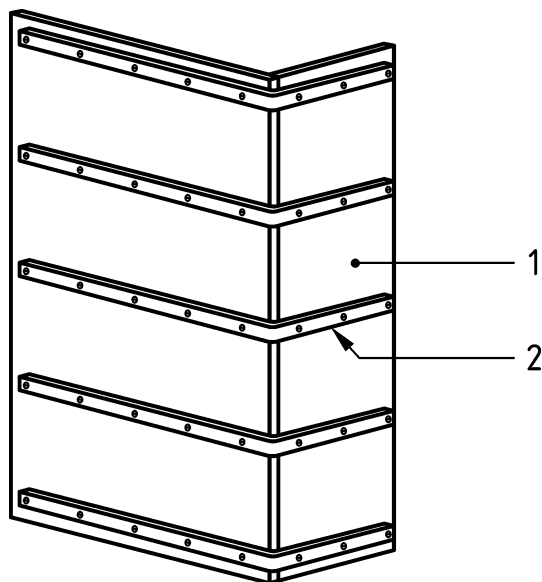

Key

- 1 substrate
- 2 steel brackets (width 30 mm, thickness 5 mm)

Figure H.1 — L-shaped substrate support for the preparation of the test specimen: view of the external surface of the substrate

H.3.2.2 Exposure to thermal attack

Most thermal insulation products will be incorporated into an assembled building system (end-use application) with the thermal insulation product not directly exposed to a heat or fire source. In the case of a standard test configuration of assemblies where the thermal insulation product is directly exposed to a heat or fire source, the standard test configuration of assembly number 1 in Table H.3 shall be followed.

When the product is not directly exposed in end-use application, another product immediately in front, shall be applied so as to simulate the performance of the combination of these products in their end-use application. This product in front is designated as the surface product. Standardised surface products, such as particleboard, steel sheet and plasterboard shall be used (see H.3.2.3).

Table H.3 — Standard test configurations of assemblies

Number	Substrate\ (see H.3.2.4)	air gap between substrate and insulation product	Insulation product	surface product (see H.3.2.3)
1	plasterboard	no	X	none
2	plasterboard	no	X	plasterboard
3	none	yes 40 mm	X	corrugated steel
4	particle board	no	X	particle board

H.3.2.3 Surface products

For testing of the assembled systems given in Table H.3, the following products shall be used as surface products:

- Paper faced gypsum plaster board according to EN 520 with a thickness of 9,5 mm, density 600 kg/m³ and a paper grammage of not more than 220 g/m² (CWFT Euroclass A2).
- Particle board, non-fire retardant, treated according to EN 312 with a thickness of 9 mm to 10 mm and a density of (650 ± 50) kg/m³ (CWFT Euroclass D).
- Steel sheet with polyester coating (if any) according to EN 508-1 with corrugated profile of 100 mm to 110 mm depth and 250 mm to 275 mm pitch (for example 106/250) and a thickness of (0,75 ± 0,1) mm (CWFT Euroclass A1). The maximum nominal thickness of polyester coating on the exposed face shall be 25 µm with a maximum mass/unit area of 70 gr/m² and with a maximum PCS of 1,0 MJ/m². On the non-exposed face, the maximum nominal thickness shall be 15 µm with a maximum PCS of 1,0 MJ/m².

H.3.2.4 Substrate

Test specimens are tested using the standard mounting (see EN 13238 and EN 13823) with paper-faced plasterboard representing all end-use non-wood based substrates and non-fire retardant treated particleboard representing all end-use wood based substrates.

The test conditions and field of application of the classification shall be given in the declaration of conformity, in the classification report and in the manufacturer's technical literature.

H.3.2.5 Air gaps/cavities

There shall be no air gap between a surface product and the thermal insulation product.

The presence of an air gap between the thermal insulation product and the substrate may have an influence on the reaction to fire performance. If in the end-use application an air gap is used, then an air gap of 40 mm shall be left between the thermal insulation product and the substrate. The air gap shall be ventilated. No air gap shall be left behind the thermal insulation product, if the thermal insulation product is tested behind a surface product of plasterboard or particle board (see Table H.3).

H.3.2.6 Joints/edges

H.3.2.6.1 Joints in surface products

Joints shall be considered as described for fixing of the surface products (see H.3.2.8.2).

The butt corner joint (if any) shall not be covered with a flashing or a sealant, except for corrugated steel where a flashing is needed.

H.3.2.7 Size and positioning of test specimen

The configuration of the test specimen is given in Table H.3.

H.3.2.8 Mounting and fixing of the test specimen

H.3.2.8.1 Reporting

The test conditions and field of application of the classification shall be given in the declaration of conformity, in the classification report and in the manufacturer's technical literature.

H.3.2.8.2 Fixing of the thermal insulation product to the substrate

Fixing of the products and test specimens shall be carried out in accordance with the standard test configuration of the assembly.

The specimen with its substrate shall be fixed in the test apparatus by clamping and maintained between the backing boards and the U profile at the bottom part of the frame, and the calcium silicate support at the top of the frame (see Figure H.2).

If necessary, the natural skin surface may be removed in places to create a flatter surface so that the test specimen will fit snugly against the U-profile section at the base of the apparatus adjacent to the burner. It may be necessary for example to remove sufficient foam internally at the corner to again allow a snug fit of the test specimen at the corner.

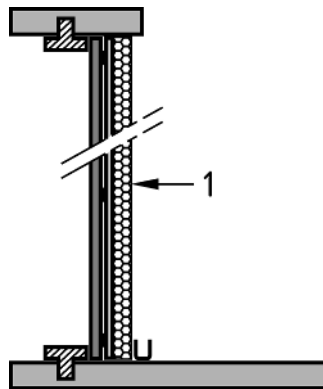

Key

1 test specimen

Figure H.2 — Principle for maintaining of test specimen by clamping (cross section)

H.3.2.8.3 Fixing of the surface product to the thermal insulation product

Surface products such as the paper-faced plasterboards and the wooden particle boards shall be fixed through the thermal insulation product without air gap using screws, taking into account the position of joints in the surface products in accordance with EN 13823:2010, 5.2.2.e.

For testing with the corrugated steel sheet as surface product, fixing of the steel sheet shall be done in the configuration as given in Figure H.3.

The vertical joint(s) shall be made in the steel sheet in accordance with EN 13823:2010, 5.2.2.e and fastened according to the end-use conditions (e.g. three rivets for corrugated steel sheets).

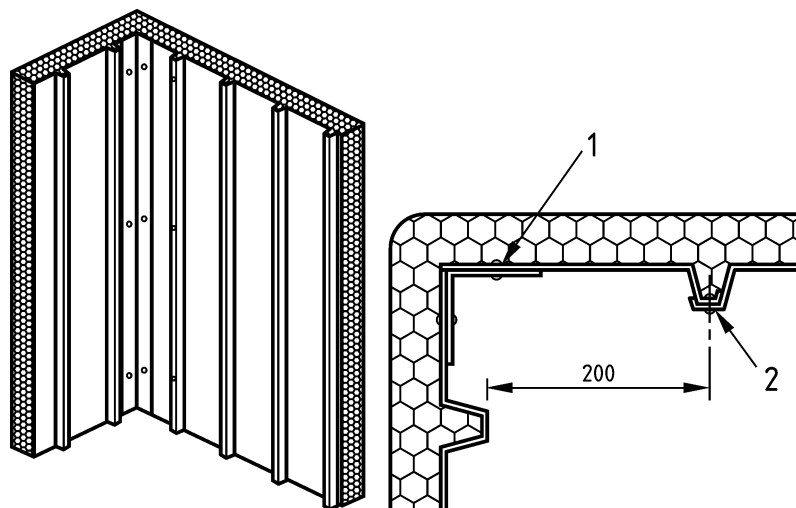

Key

- 1 fixing with L-profile and 2 x 3 rivets
- 2 fixing with 3 rivets

Figure H.3 — Fixing corrugated steel sheet type 106/250

H.4 Field of application

The manufacturer is responsible for the grouping of his products following the rules described in EN 13172 and this standard. The validity of the test results and the field of application for a product group are determined by the product parameters and the installation parameters, which have been taken into account in the testing (see Tables H.4 and H.5).

Table H.4 — Product parameters

Product parameter	Validity of test results			
	EN ISO 1182	EN ISO 1716	EN 13823	EN ISO 11925-2 (Ignitability)
	Not relevant	Not relevant		
Thickness			Test results are valid for equal or lower thickness.	
			Test results on a 180 mm thickness are also valid for higher thickness.	Test results on 60 mm thickness are also valid for higher thickness.
Density			Product density $\pm 15\%$	
Type of product, e.g. PUR or PIR			For the tested type only	

Table H.5 — Installation parameters

Installation parameter	Validity of test results	
	EN 13823 (SBI)	EN ISO 11925-2 (Ignitability)
Exposure to thermal attack	<p>Without surface product (no.1 of Table H.3): Test result is valid for product applied without surface product (s). The classification obtained is also valid for assemblies when a covering or protecting layer having Euroclass A1 and A2 is placed in front of the thermal insulation product in the end-use.</p> <p>Plasterboard surface product (no.2 of Table H.3): Test results are valid for all non-combustible mineral surface products of Euroclasses A1 and A2 with equal or higher thickness and with equal or higher densities.</p> <p>Corrugated steel sheet surface product (no.3 of Table H.3): Test results are valid for all corrugated steel sheets such as defined in H.3.2.3 and for steel sheets without corrugation or with other type of corrugation and with equal or higher steel thickness. Test results are valid also for other type of organic coating of the steel sheet with equal or lower PCS value and with equal or lower thickness of the coating.</p> <p>Particle board surface product (no.4 of Table H.3): Test results are valid for all types of wooden boards of Euroclass D or higher and with equal or higher thickness and with equal or higher densities.</p>	See H.3.1.1
Substrate	Test results only valid for product applied with the substrate used in the test. For insulation product thickness min. 80 mm or higher when testing without surface product or with steel sheet surface product and for any product thickness when testing with plasterboard or particle board as surface product, test result with any substrate is valid for all types of substrate (including combustible types, e.g. particle board).	Not relevant
Air gap / cavities	Test results are also valid for larger air gaps. Test results from a test where an air gap has been included are also valid for assemblies without an air gap; for products tested behind the standardised surface products and for products tested without surface products having thickness of min. 80 mm or higher, test result without air gap is also valid for assemblies with air gap.	Not relevant
Joints of surface product	Test results are valid also for setups without joints.	Not relevant
Edges of surface product	If tested butt jointed with square edges, then valid for all profiled edge finishing.	Not relevant
Fixing of test specimen and surface product	Test results using clamping are valid also for mechanical fixing.	Not relevant

Annex I (informative)

Example for the determination of the declared aged values of thermal conductivity and thermal resistance for a product

Case where both thermal conductivity and thermal resistance are declared

NOTE The values given in this example are illustrative only and are not typical of polyurethane or polyisocyanurate products.

If fourteen test results of the aged thermal conductivity are available for a product obtained by direct measurements in accordance with 5.3.2, as exemplified in Table I.1, the mean aged thermal conductivity is the arithmetical average of the fourteen test results

$$\lambda_{\text{mean,a}} = 0,040 \text{ 1 W/(m}\cdot\text{K)} \quad (I.1)$$

Table I.1 — λ test results

Test result number	λ W/(m·K)
1	0,036 6
2	0,039 0
3	0,038 2
4	0,037 8
5	0,041 0
6	0,041 2
7	0,039 7
8	0,041 7
9	0,041 5
10	0,040 2
11	0,041 7
12	0,040 6
13	0,040 8
14	0,042 1

The factor, k , related to the number of test results available (i.e. fourteen) is taken from Table A.1, $k = 1,90$. The estimate of the standard deviation of the aged thermal conductivity, $s_{\lambda a}$, is determined using Formula A.2:

$$s_{\lambda} = \sqrt{\frac{\sum_{i=1}^{14} (\lambda_i - 0,0401)^2}{14 - 1}} \quad (I.2)$$

The calculated aged thermal conductivity, $\lambda_{90/90}$, is determined using Formula A.1:

$$\lambda_{90/90} = 0,040 \text{ 1} + 1,90 \cdot 0,001 \text{ 66} = 0,043 \text{ 3 W(m}\cdot\text{K)}$$

The resulting declared thermal conductivity, rounded upwards to the nearest 0,001 W/(m·K) following the rounding rules in 4.2.1, is 0,044 W/(m·K).

For a product having a nominal thickness of 80 mm, the calculated aged thermal resistance, $R_{90/90}$, is determined using Formula A.3.

$$R_{90/90} = 0,080 / 0,0433 = 1,848 \text{ m}^2\cdot\text{K}/\text{W}$$

The resulting declared aged thermal resistance, rounded downwards to the nearest 0,05 m²·K/W following the rounding rules given in 4.2.1 is 1,80 m²·K/W.

NOTE The declared installed aged thermal resistance for the product is declared in Part 2 of EN 14315 by the installer.

Annex J (normative)

Instructions for compiling thermal resistance performance charts

J.1 Introduction

In general, the thermal conductivity ageing characteristics of in-situ polyurethane and polyisocyanurate insulating products are more complicated than for factory made products. Those products give comparable results to in-situ products for only one class of in-situ products, namely the in-situ products in the CCC4 class. This is because both factory made products and CCC4 in-situ products have closed cell contents of 90 % or more and use similar blowing agents which are retained in the cells for more than their economic life and are thus known as “permanent” blowing agents. These blowing agents have very low gaseous thermal conductivities and so the initial thermal conductivities of these types of products are lower than products where the cells contain air. Ageing occurs therefore by ingress of air by diffusion into these closed cells to increase the cell gas thermal conductivity of the resulting cell gas mixture, if this is not prevented by diffusion resistant product surface coverings.

In contrast, the in-situ products which have no closed cells show no thermal conductivity ageing since air at ambient pressure is present in the product in the same way as other solid material based in-situ products. Polyurethane and polyisocyanurate in-situ products in class CCC1 having closed cell contents below 20 % almost reach this situation as only a very small fraction of the cells can perform the ageing process characteristic of the CCC4 products, again only if inward air diffusion is not prevented by suitable surface barriers. However, their initial thermal conductivities will be higher than for CCC4 products since the CCC4 products contain only a minute amount of air initially.

It follows therefore that the increases in thermal conductivity due to ageing which occur due to air diffusion (if not prevented) for the products with intermediate classes of closed cells, i.e. for those products in classes CCC3 and CCC2, will in general be less than those for the products in CCC4 class but greater than for those products in the CCC1 class. It also follows that their initial values will lie between those of classes CCC4 and CCC1.

Because the ageing process is one of air diffusion, the effect on the conductivity is thickness dependent with outer cells needing to build up a partial pressure of air gases before any transfer can take place to cells in the next layer. Thus as the thickness of the product increases it takes longer for the cells in the interior layers of the product to be affected.

The heat ageing procedure embodied in Annex C has been established to simulate the degree of ageing corresponding to the time average for 25 years so that a meaningful value for the calculation of heat losses for the product used over its economic life can be established to satisfy the CPD.

Accordingly, for example, for factory made products and especially with CCC4 in-situ products used in buildings, the resulting aged value is very dependent on its thickness, while those in class CCC1 will show the smallest dependence on thickness.

J.2 General

A performance chart is a table giving the declared aged thermal conductivity values for different installed insulation thicknesses and the corresponding declared thermal resistances.

Examples of the format of performance charts in Tables J.1, J.2 and J.3 give guidance which indicates the aged thermal performance as a function of thickness for the different application conditions in which the product is created. For example, Table J.3 reflects the situation where the product is sprayed onto a substrate which prevents gaseous diffusion and the open surface of the product has also been sealed to prevent gaseous diffusion by the application of an impervious coating. Table J.2 data refers to an impervious substrate

but the outer surface is not sealed or covered with an impervious cover. Table J.1 data applies when gaseous diffusion through both sides of the final product is possible.

The manufacturer of the in-situ formed sprayed rigid polyurethane or polyisocyanurate foam insulation system shall calculate the values of the thermal resistance to be stated in the performance chart in accordance with the procedure given in J.3.

By definition, the initial values of thermal conductivity are independent of the insulation thickness. Nevertheless the increments or the safety increments used to determine the aged thermal conductivity (see Annex C) may vary with the nominal thickness. For this reason, the aged thermal conductivity is declared in the performance chart as a function of the insulation thickness.

Table J.1 — Example of the format of a performance chart for thermal resistance of sprayed insulation for CCC4 products: Diffusion open faces (see Annex C)

Type of facing: Diffusion open faces		
Thickness	Declared aged thermal conductivity (λ_D) W/m·K	Thermal resistance level (R_D) m²·K/W
30 mm	λ_D	$R_D \dots$
	λ_D	$R_D \dots$
	λ_D	$R_D \dots$
	λ_D	$R_D \dots$
	λ_D	$R_D \dots$

Table J.2 — Example of the format of a performance chart for thermal resistance of sprayed insulation for CCC4 products: One diffusion open face and one diffusion tight face (see Annex C)

Type of facing: One diffusion open face and one diffusion tight face		
Thickness	Declared aged thermal conductivity (λ_D) W/m·K	Thermal resistance level (R_D) m²·K/W
30 mm	λ_D	$R_D \dots$
	λ_D	$R_D \dots$
	λ_D	$R_D \dots$
	λ_D	$R_D \dots$
	λ_D	$R_D \dots$

Table J.3 — Example of the format of a performance chart for thermal resistance of sprayed insulation for CCC4 products: Diffusion tight faces (see Annex C)

Type of facing: Diffusion tight faces		
Thickness	Declared aged thermal conductivity (λ_D) W/m·K	Thermal resistance level (R_D) m²·K/W
30 mm	λ_D	$R_D \dots$
	λ_D	$R_D \dots$
	λ_D	$R_D \dots$
	λ_D	$R_D \dots$
	λ_D	$R_D \dots$

J.3 Procedure for the manufacturer to create the performance charts

J.3.1 Performance charts for diffusion open faces

Introduce in the chart heading the term “Diffusion open faces”.

Choose a range of thicknesses which covers the intended applications of the product.

For each value of thickness determine the declared aged thermal conductivity, λ_D (W/m·K) for the product according to C.4. Select the correct safety increments from Table C.1 for the measured accelerated aged value or increments for the calculated aged value, if appropriate, from Table C.2.

- none or diffusion open facings;
- blowing agent of the system in question;
- value of the thickness.

For each value of thickness, calculate the corresponding thermal resistance value, R_D , using the formula:

$$R_D = d_N / \lambda_D \quad (J.1)$$

Values of the thermal conductivity and thermal resistance shall be declared as follows:

- For thicknesses declare in steps of 5 mm.
- Insert the corresponding declared aged thermal conductivity, λ_D , rounded to nearest 0,001 W/(m·K).
- Insert the corresponding declared thermal resistance level, R_D , rounded to nearest 0,05 m²·K/W.

Insert these values into the chart following the example given in Table J.4.

Table J.4 – Example of a performance chart for a sprayed insulation foam product derived from a CCC4 system expanded with either HFC365mfc, 227ea or 245fa: Diffusion open faces (1 of 2)

Type of facing: Diffusion open faces		
Thickness	Declared aged thermal conductivity (λ_D) W/m·K	Thermal resistance level (R_D) m ² ·K/W
40 mm	0,028	1,45
45 mm	0,028	1,60
50 mm	0,028	1,80
55 mm	0,028	1,95
60 mm	0,028	2,15
65 mm	0,028	2,30
70 mm	0,028	2,50
75 mm	0,028	2,70

Table J.4 (2 of 2)

Type of facing: Diffusion open faces		
Thickness	Declared aged thermal conductivity (λ_D) W/m·K	Thermal resistance level (R_D) m ² ·K/W
80 mm	0,027	3,00
85 mm	0,027	3,15
90 mm	0,027	3,35
95 mm	0,027	3,55
100 mm	0,027	3,75
105 mm	0,027	3,90
110 mm	0,027	4,10
115 mm	0,027	4,30
120 mm	0,026	4,65
125 mm	0,026	4,85

J.3.2 Performance chart for one diffusion open face and one diffusion tight face

Introduce into the chart heading the term "one diffusion open face and one diffusion tight face".

Choose a range of thicknesses which covers the intended applications of the product.

For each value of thickness, determine the declared aged thermal conductivity, λ_D (W/m·K) for the product according to C.4, selecting the correct safety increments from Table C.1 and if applicable the increments from Table C.2. When using safety increments for the measured accelerated aged value or increments for the calculated aged value, take into account the following input data to select the right increment:

For each value of thickness, calculate the corresponding R_D using the formula:

$$R_D = d_N / \lambda_D. \tag{J.2}$$

All calculations are declared in levels as follows:

- For thicknesses declare in steps of 5 mm.
- Declare aged thermal conductivity, λ_D rounded to nearest 0,000 1 W/(m·K) and thermal resistance level, R_D , rounded to nearest 0,001 m²/K/W.

Insert these values into the chart following the example given in Table J.5.

Table J.5 – Example of a performance chart for a sprayed insulation foam product derived from a CCC4 system expanded with either HFC365mfc, 227ea or 245fa: One diffusion open face and one diffusion tight face

Type of facing: Diffusion open faces		
Thickness	Declared aged thermal conductivity (λ_D) W/m·K	Thermal resistance level (R_D) m ² ·KW
30 mm	0,028	1,07
35 mm	0,028	1,25
40 mm	0,028	1,50
45 mm	0,027	1,70
50 mm	0,027	1,85
55 mm	0,027	2,05
60 mm	0,026	2,35
65 mm	0,026	2,50
70 mm	0,026	2,70
75 mm	0,026	2,90
80 mm	0,026	3,10
85 mm	0,026	3,30
90 mm	0,026	3,50

J.3.3 Performance chart for diffusion tight faces

Introduce in the chart heading the term "Diffusion tight faces".

Choose a range of thicknesses which covers the applications of the product in question.

For each value of thickness, determine the declared aged thermal conductivity, λ_D (W/m·K) for the product according to Annex C. When using safety increments for the measured accelerated aged value or increments for the calculated aged value, take into account the following input data to select the right increment:

- diffusion tight facings, for the safety increments to the measured accelerated aged value, or both faces diffusion tight, for the increments to the calculated aged value;
- blowing agent of the system in question;
- value of the thickness.

For each value of thickness calculate the corresponding R_D using the formula:

$$R_D = d_N / \lambda_D \tag{J.3}$$

All calculations are declared in levels as follows:

For thicknesses, declare in steps of 5 mm.

Declare aged thermal conductivity, λ_D , rounded to nearest 0,000 1 W/(m·K) and thermal resistance level, R_D , rounded to nearest 0,001 m²·KW.

Insert these values into the chart following the example given in Table J.6.

Table J.6 – Example of a performance chart for a sprayed insulation foam product derived from a CCC4 system expanded with either HFC365mfc, 227ea or 245fa: Diffusion tight faces

Type of facing: Diffusion tight faces		
Thickness	Declared aged thermal conductivity (λ_D) W/m·K	Thermal resistance level (R_D) m²·K/W
30 mm	0,024	1,30
35 mm	0,024	1,50
40 mm	0,024	1,70
45 mm	0,024	1,90
50 mm	0,024	2,15
55 mm	0,024	2,35
60 mm	0,024	2,55
65 mm	0,024	2,75
70 mm	0,024	3,00
75 mm	0,024	3,20
80 mm	0,024	3,40
85 mm	0,024	3,60
90 mm	0,024	3,85

J.3.4 For products classified CCC4

As the aged value of thermal conductivity is very dependent on the thickness of the product as well as whether there are any diffusion resistant coverings used with the product in its end-use application, it is necessary to state the thermal resistance according to thickness in the three special conditions regarding any diffusion resistant coverings in the examples of the format of performance tables illustrated in Tables J.1, J.2 and J.3.

J.3.5 For products classified CCC1

Here, if there were no closed cells present, there would be no ageing and therefore the thermal resistance would be purely a function of thickness only. Accordingly, the manufacturer may consider that it is unnecessary to take into account the presence or otherwise of any diffusion resistant barriers used with the product in its end-use application. The decision will depend on the level of closed cells characteristic of the product which by definition is not greater than 20 %.

J.3.6 For products classified CCC2 and CCC3

These products have closed cell contents which vary between 20 % and 89 %. They will therefore require performance charts constructed in the same manner as those in class CCC4. However, the degree of variation of the final aged values of thermal resistance with thickness will clearly be less than that appropriate to products in the CCC4 class.

Annex ZA (informative)

Clauses of this European Standard addressing the provisions of the EU Construction Products Directive

ZA.1 Scope and relevant characteristics

This European Standard has been prepared under a mandate M103¹⁾ “Thermal insulation products” given to CEN by the European Commission and the European Free Trade Association.

The clauses of this European Standard, shown in the table below, meet the requirements of the Mandate M/103 given under the EU Construction Products Directive (89/106/EEC).

Compliance with these clauses confers a presumption of fitness of the In-situ formed sprayed rigid polyurethane (PUR) and polyisocyanurate (PIR) foam products covered by this European Standard for the intended uses indicated herein; reference shall be made to the information accompanying the CE marking.

This annex establishes the conditions for the CE marking of the In-situ formed sprayed rigid polyurethane (PUR) and polyisocyanurate (PIR) foam products intended for the uses indicated in Table ZA.1 and shows the relevant clauses applicable:

This annex has the same scope as the relevant part in Clause 1 of this standard related to the aspect covered by the mandate and is defined by Table ZA.1.

1) As amended.

Table ZA.1 — Relevant clauses for in-situ formed sprayed rigid polyurethane (PUR) and polyisocyanurate (PIR) foam products and thermal insulation

Construction Products: In-situ formed sprayed rigid polyurethane (PUR) and polyisocyanurate (PIR) foam products as covered by the scope of this standard			
Intended uses: Thermal insulation of walls, ceilings, roofs, suspended ceilings and floors			
Requirement/Characteristic from the mandate	Requirement clauses in this European Standard	Levels and/or classes	Notes ^a
Reaction to fire	4.2.3 Reaction to fire	Euroclasses	-
Water permeability	4.3.3 Short term water absorption by partial immersion	-	-
Thermal resistance	4.2.2 Thermal resistance and thermal conductivity	-	Levels of λ
Water vapour permeability	4.3.2 Water vapour transmission	-	-
Compressive strength	4.3.4 Compressive stress or compressive strength	-	Levels
Durability of reaction to fire against ageing/degradation	4.2.5.2 Durability characteristics	-	-
Durability of thermal resistance against ageing/degradation	4.2.5.3 Durability characteristics	-	Levels
Durability of compressive strength against ageing/degradation	4.2.5.4 Durability characteristics	-	-
Continuous glowing combustion	4.3.10 ^a Continuous glowing combustion	-	-

^a The test method is under development.

The requirement on a certain characteristic is not applicable in those Member States (MSs) where there are no regulatory requirements on that characteristic for the intended use of the product. In this case, manufacturers placing their products on the market of these MSs are not obliged to determine nor declare the performance of their products with regard to this characteristic and the option “No performance determined” (NPD) in the information accompanying the CE marking (see ZA.3) may be used. The NPD option may not be used, however, for durability and where the characteristic is subject to a threshold level.

ZA.2 Procedures for attestation of conformity of rigid PU products

ZA.2.1 Systems of attestation of conformity

The systems of attestation of conformity of in-situ formed dispensed rigid polyurethane (PUR) and rigid polyisocyanurate foam (PIR) products, indicated in Table ZA.1 in accordance with the decision of the European Commission 95/204/EC of 30.04.95 revised by decision 99/91/EC of 25.01.99 and by the Commission Decision 2001/596/EEC and as given in Annex III of the mandate M103 for thermal insulation as amended by mandates M126, M130 and M367 is shown in Table ZA.2 for the indicated intended use(s) and relevant level(s) or class(es).

Table ZA.2 — System(s) of attestation of conformity

Product(s)	Intended use(s)	Level(s) or class(es) (reaction to fire)	Attestation of conformity system(s)
Thermal insulation products (Products intended to be formed in-situ)	For uses subject to regulations on reaction to fire	A1 ⁽¹⁾ , A2 ⁽¹⁾ , B ⁽¹⁾ , C ⁽¹⁾	1
		A1 ⁽²⁾ , A2 ⁽²⁾ , B ⁽²⁾ , C ⁽²⁾ , D, E (A1 to E) ⁽³⁾ , F	3 3 (with 4 for RtF)
	Any	-	3
System 1: See Directive 89/106/EEC (CPD) Annex III.2.(i), without audit testing of samples. System 3: See Directive 89/106/EEC (CPD) Annex III.2.(ii), Second possibility. System 4: See Directive 89/106/EEC (CPD) Annex III.2.(ii), Third possibility.			
<p>⁽¹⁾ Products/materials for which a clearly identifiable stage in the production process results in an improvement of the reaction to fire classification (e.g. an addition of fire retarders or a limiting of organic material).</p> <p>⁽²⁾ Products/materials not covered by footnote 1.</p> <p>⁽³⁾ Products/materials that do not require to be tested for reaction to fire (e.g. products/materials of classes A1 according to the Decision 96/603/EC, as amended).</p>			

The attestation of conformity of the in-situ formed sprayed rigid polyurethane (PUR) and polyisocyanurate (PIR) foam products in Table ZA.1 shall be based on the evaluation of conformity procedures indicated in Tables ZA.3.1 to ZA.3.2 resulting from application of the clauses of this or other European Standards indicated therein.

Table ZA.3.1 — Assignment of evaluation of conformity tasks for In-situ formed sprayed rigid polyurethane (PUR) and polyisocyanurate (PIR) foam products under system 1 subject to reaction to fire classes A1⁽¹⁾, A2⁽¹⁾, B⁽¹⁾, C⁽¹⁾ (1 of 2)

Tasks	Content of the task	Evaluation of conformity Relevant clauses of EN 13172 and of this standard
Tasks under the responsibility of the manufacturer	Factory production control (F.P.C)	Parameters related to all relevant characteristics of Table ZA.1
	Further testing of samples taken at factory	All relevant characteristics of Table ZA.1
	Initial type testing	Those relevant characteristics of Table ZA.1 not tested by the notified body
	Initial testing by a Notified laboratory	- Thermal resistance - Release of dangerous substances - Compressive strength (for load bearing applications) - Water permeability
		<p>Clauses 1 to 5, Annexes B and C of EN 13172:2012 and 7.3 of this standard</p> <p>Annex B of this standard</p> <p>Clause 6 of EN 13172:2012 and 7.2 of this standard</p> <p>Clause 6 of EN 13172:2012 and 7.2 of this standard</p>

Table ZA.3.1 — Assignment of evaluation of conformity tasks for In-situ formed sprayed rigid polyurethane (PUR) and polyisocyanurate (PIR) foam products under system 1 subject to reaction to fire classes A1⁽¹⁾, A2⁽¹⁾, B⁽¹⁾, C⁽¹⁾ (2 of 2)

Tasks		Content of the task	Evaluation of conformity Relevant clauses of EN 13172 and of this standard
Tasks under the responsibility of the notified certification body	Initial type testing	Reaction to fire	Clause 6 of EN 13172:2012 and 7.2 of this standard
	Initial inspection of factory and of F.P.C	Parameters related to the relevant characteristics of Table ZA.1, namely reaction to fire.	Annex B and C of EN 13172:2012 and 7.3 of this standard
	Continuous surveillance, assessment and approval of F.P.C.	Parameters related to the relevant characteristics of Table ZA.1, namely reaction to fire.	Annex B and C of EN 13172:2012 and 7.3 of this standard

Table ZA.3.2 — Assignment of evaluation of conformity tasks for In-situ formed sprayed rigid polyurethane (PUR) and polyisocyanurate (PIR) foam products under system 3 and 3 for products subject to reaction to fire classes A1⁽²⁾, A2⁽²⁾, B⁽²⁾, C⁽²⁾, D, E (with 4 for reaction to fire classes RtF)

Tasks		Content of the task	Evaluation of conformity Relevant clauses of EN 13172 and of this standard
Tasks for the manufacturer	Factory production control (F.P.C)	Parameters related to all relevant characteristics of Table ZA.1	7.3 of this standard and Clauses 1 to 5 of EN 13172:2012 and: For system 3, 7.3 of EN 13172:2012 For system 3 (with 4 for RtF) Annex C and D of EN 13172:2012
	Initial type testing	Those relevant characteristics of Table ZA.1 not tested by the notified laboratory including reaction to fire (for system 3 & 4)	Clause 6 of EN 13172:2012 and 7.2 of this standard
Tasks for the notified laboratory	Initial type testing	<ul style="list-style-type: none"> - Reaction to fire (system 3) - Thermal resistance - Release of dangerous substances - Compressive strength (for load bearing applications) - Water permeability 	Clause 6 of EN 13172:2012 and 7.2 of this standard

ZA.2.2 EC certificate and declaration of conformity

(In case of products under system 1): When compliance with the conditions of this annex is achieved, the certification body shall draw up a certificate of conformity (EC Certificate of conformity), which entitles the manufacturer to affix of the CE marking. The certificate shall include:

- name, address and identification number of the certification body;
- name and address of the manufacturer, or his authorised representative established in the EEA, and place of production;

NOTE 1 The manufacturer may also be the person responsible for placing the product onto the EEA market, if he takes responsibility for the CE marking.

- description of the product (type, identification, use, ...);
- provisions to which the product conforms (e.g. Annex ZA of this European Standard);
- particular conditions applicable to the use of the product (e.g. provisions for use under certain conditions, etc.);
- the number of the certificate;
- conditions and period of validity of the certificate, where applicable;
- name of, and position held by, the person empowered to sign the certificate.

(In case of products under system 3 or (3 (with 4 for RtF)): When compliance with the conditions of this annex is achieved, the manufacturer or his agent established in the EEA shall draw up and retain the EC Declaration of conformity, which entitles the manufacturer to affix the CE marking. This EC declaration of conformity shall include:

- name and address of the manufacturer, or his authorised representative established in the EEA, and place of production;

NOTE 2 The manufacturer may also be the person responsible for placing the product onto the EEA market, if he takes responsibility for CE marking.

- description of the product (type, identification, use,...), and a copy of the information accompanying the CE marking;

NOTE 3 Where some of the information required for the Declaration is already given in the CE marking information, it does not need to be repeated.

- provisions to which the product conforms (i.e. Annex ZA of this European Standard), and a reference to the ITT report(s) and factory production control records (if appropriate);
- particular conditions applicable to the use of the product, (e.g. provisions for use under certain conditions);
- name and address of the notified laboratory(ies);
- name of, and position held by, the person empowered to sign the declaration on behalf of the manufacturer or his authorised representative.

The above mentioned declaration and certificate shall be presented in the official language or languages of the Member State in which the product is to be used.

ZA.3 CE Marking and labelling

The manufacturer or his authorised representative established within the EEA is responsible for the affixing of the CE marking. The CE marking symbol to affix shall be in accordance with Directive 93/68/EEC and shall be shown on the product itself, on the accompanying label or on the packaging. The following information shall accompany the CE marking symbol:

- a) identification number of the certification body (only for products under systems 1);
- b) name or identifying mark and registered address of the producer;
- c) the last two digits of the year in which the marking is affixed;
- d) number of the EC Certificate of conformity (if relevant);
- e) reference to this European Standard;
- f) description of the product: generic name, material, dimensions, ... and intended use;
- g) information on those relevant essential characteristics listed in Table ZA.1 which are to be declared presented as:
- h) as standard designation(s) in combination with declared values as described in Clause 6.

NOTE Care will be taken that using standard designation does not bring information on non-harmonised characteristics into the CE marking.

The “No performance determined” (NPD) option may not be used where the characteristic is subject to a threshold level. Otherwise, the NPD option may be used when and where the characteristic, for a given intended use, is not subject to regulatory requirements in the Member State of destination.

Figure ZA.1 gives an example of the information to be given on the product, label, packaging and/or commercial documents.

 0123	<p><i>CE marking, consisting of the “CE”-symbol given in Directive 93/68/EEC.</i></p> <p><i>Identification number of the certification body (for products under system 1)</i></p>
AnyCo Ltd, PO Box 21, B-1050 13 0123-CPD-00234	<p><i>Name or identifying mark and registered address of the producer</i></p> <p><i>Last two digits of the year in which the marking was affixed</i></p> <p><i>Certificate number (for products under system 1)</i></p>
EN 14315-1 Product- Sprayed PU foam, intended to be used in roof insulation Reaction to fire – E Thermal conductivity : See performance charts Water vapour transmission (expressed as water vapour resistance factor μ)60 Compressive strength >200 kPa Continuous glowing combustion (no performance determined) PU EN 14315-1-MU60-CS(Y)3	<p><i>No. of dated version of European Standard Description of product Information on Essential Characteristics</i></p> <p style="text-align: center;">Reaction to fire-Euroclass</p> <p style="text-align: center;">Designation code (in accordance with Clause 6 of this standard for the relevant characteristics according to Table ZA.1)</p>

Figure ZA.1 — Example CE marking information

Bibliography

- [1] ISO 12491, *Statistical methods for quality control of building materials and components*
- [2] ASTM 3985, *Standard Test Method for Oxygen Gas Transmission Rate Through Plastic Film and Sheeting Using a Coulometric Sensor*
- [3] EN 14315-2, *Thermal insulation products for buildings — In-situ formed sprayed rigid polyurethane (PUR) and polyisocyanurate (PIR) foam products — Part 2: Specification for the installed products*

British Standards Institution (BSI)

BSI is the national body responsible for preparing British Standards and other standards-related publications, information and services.

BSI is incorporated by Royal Charter. British Standards and other standardization products are published by BSI Standards Limited.

About us

We bring together business, industry, government, consumers, innovators and others to shape their combined experience and expertise into standards-based solutions.

The knowledge embodied in our standards has been carefully assembled in a dependable format and refined through our open consultation process. Organizations of all sizes and across all sectors choose standards to help them achieve their goals.

Information on standards

We can provide you with the knowledge that your organization needs to succeed. Find out more about British Standards by visiting our website at bsigroup.com/standards or contacting our Customer Services team or Knowledge Centre.

Buying standards

You can buy and download PDF versions of BSI publications, including British and adopted European and international standards, through our website at bsigroup.com/shop, where hard copies can also be purchased.

If you need international and foreign standards from other Standards Development Organizations, hard copies can be ordered from our Customer Services team.

Subscriptions

Our range of subscription services are designed to make using standards easier for you. For further information on our subscription products go to bsigroup.com/subscriptions.

With **British Standards Online (BSOL)** you'll have instant access to over 55,000 British and adopted European and international standards from your desktop. It's available 24/7 and is refreshed daily so you'll always be up to date.

You can keep in touch with standards developments and receive substantial discounts on the purchase price of standards, both in single copy and subscription format, by becoming a **BSI Subscribing Member**.

PLUS is an updating service exclusive to BSI Subscribing Members. You will automatically receive the latest hard copy of your standards when they're revised or replaced.

To find out more about becoming a BSI Subscribing Member and the benefits of membership, please visit bsigroup.com/shop.

With a **Multi-User Network Licence (MUNL)** you are able to host standards publications on your intranet. Licences can cover as few or as many users as you wish. With updates supplied as soon as they're available, you can be sure your documentation is current. For further information, email bsmusales@bsigroup.com.

BSI Group Headquarters

389 Chiswick High Road London W4 4AL UK

Revisions

Our British Standards and other publications are updated by amendment or revision.

We continually improve the quality of our products and services to benefit your business. If you find an inaccuracy or ambiguity within a British Standard or other BSI publication please inform the Knowledge Centre.

Copyright

All the data, software and documentation set out in all British Standards and other BSI publications are the property of and copyrighted by BSI, or some person or entity that owns copyright in the information used (such as the international standardization bodies) and has formally licensed such information to BSI for commercial publication and use. Except as permitted under the Copyright, Designs and Patents Act 1988 no extract may be reproduced, stored in a retrieval system or transmitted in any form or by any means – electronic, photocopying, recording or otherwise – without prior written permission from BSI. Details and advice can be obtained from the Copyright & Licensing Department.

Useful Contacts:

Customer Services

Tel: +44 845 086 9001

Email (orders): orders@bsigroup.com

Email (enquiries): cservices@bsigroup.com

Subscriptions

Tel: +44 845 086 9001

Email: subscriptions@bsigroup.com

Knowledge Centre

Tel: +44 20 8996 7004

Email: knowledgecentre@bsigroup.com

Copyright & Licensing

Tel: +44 20 8996 7070

Email: copyright@bsigroup.com



...making excellence a habit.™