

Ventilation for buildings — Air terminal devices — Method for airflow measurement by calibrated sensors in or close to ATD/plenum boxes

The European Standard EN 14277:2006 has the status of a
British Standard

ICS 91.140.30

National foreword

This British Standard was published by BSI. It is the UK implementation of EN 14277:2006.

The UK participation in its preparation was entrusted to Technical Committee RHE/2, Ventilation for buildings, heating and hot water services.

A list of organizations represented on RHE/2 can be obtained on request to its secretary.

This publication does not purport to include all the necessary provisions of a contract. Users are responsible for its correct application.

Compliance with a British Standard cannot confer immunity from legal obligations.

This British Standard was published under the authority of the Standards Policy and Strategy Committee on 30 November 2006

© BSI 2006

ISBN 0 580 49542 6

Amendments issued since publication

Amd. No.	Date	Comments

ICS 91.140.30

English Version

Ventilation for buildings - Air terminal devices - Method for airflow measurement by calibrated sensors in or close to ATD/plenum boxes

Systèmes de ventilation pour les bâtiments - Bouches d'air
- Méthode de mesure du débit d'air à l'aide de capteurs
étalonnés dans ou à proximité des boîtes type
bouche/plénum

Lüftung von Gebäuden - Luftdurchlässe - Verfahren zur
Messung des Luftstroms durch kalibrierte Fühler in oder in
der Nähe von Luftdurchlässen/Überdruckkammern

This European Standard was approved by CEN on 7 July 2006.

CEN members are bound to comply with the CEN/CENELEC Internal Regulations which stipulate the conditions for giving this European Standard the status of a national standard without any alteration. Up-to-date lists and bibliographical references concerning such national standards may be obtained on application to the Central Secretariat or to any CEN member.

This European Standard exists in three official versions (English, French, German). A version in any other language made by translation under the responsibility of a CEN member into its own language and notified to the Central Secretariat has the same status as the official versions.

CEN members are the national standards bodies of Austria, Belgium, Cyprus, Czech Republic, Denmark, Estonia, Finland, France, Germany, Greece, Hungary, Iceland, Ireland, Italy, Latvia, Lithuania, Luxembourg, Malta, Netherlands, Norway, Poland, Portugal, Romania, Slovakia, Slovenia, Spain, Sweden, Switzerland and United Kingdom.



EUROPEAN COMMITTEE FOR STANDARDIZATION
COMITÉ EUROPÉEN DE NORMALISATION
EUROPÄISCHES KOMITEE FÜR NORMUNG

Management Centre: rue de Stassart, 36 B-1050 Brussels

Contents

Page

Foreword	3
1 Scope	4
2 Normative references	4
3 Terms, definitions and symbols	6
3.1 Terms and definitions	6
3.2 Symbols	8
4 Instrumentation	8
4.1 Air flow rate measurement	8
4.2 Pressure measurement	9
4.3 Temperature measurement	9
5 Sampling	10
5.1 General	10
5.2 Integral damper	10
6 Determination of the calibration curve	10
6.1 Principle	10
6.2 Test installation	10
6.3 Test procedure	12
7 Test to determine the effect of flow disturbance on measurement accuracy	13
7.1 Principle	13
7.2 Test procedure	14
8 Test report	23
8.1 Test results	23
8.2 Contents	23
Annex A (normative) Zero-pressure difference method - Principle	26

Foreword

This document (EN 14277:2006) has been prepared by Technical Committee CEN/TC 156 “Ventilation for buildings”, the secretariat of which is held by BSI.

This European Standard shall be given the status of a national standard, either by publication of an identical text or by endorsement, at the latest by March 2007, and conflicting national standards shall be withdrawn at the latest by March 2007.

According to the CEN/CENELEC Internal Regulations, the national standards organizations of the following countries are bound to implement this European Standard: Austria, Belgium, Cyprus, Czech Republic, Denmark, Estonia, Finland, France, Germany, Greece, Hungary, Iceland, Ireland, Italy, Latvia, Lithuania, Luxembourg, Malta, Netherlands, Norway, Poland, Portugal, Romania, Slovakia, Slovenia, Spain, Sweden, Switzerland and United Kingdom.

1 Scope

This European Standard specifies methods for the laboratory aerodynamic testing and rating of the air flow rate measurement accuracy of fixed air flow rate measurement devices, including supply and exhaust air terminal devices (ATD) and in-duct measurement stations (IMS) and the sensitivity of such devices to flow disturbance. A general overview of different test configurations is shown in Figure 1.

2 Normative references

The following referenced documents are indispensable for the application of this document. For dated references, only the edition cited applies. For undated references, the latest edition of the referenced document (including any amendments) applies.

EN 12238, *Ventilation for buildings — Air terminal devices — Aerodynamic testing and rating for mixed flow application*

EN 12792:2003, *Ventilation for buildings — Symbols, terminology and graphical symbols*

EN ISO 5167-1, *Measurement of fluid flow by means of pressure differential devices inserted in circular cross-section conduits running full — Part 1: General principles and requirements (ISO 5167-1:2003)*

EN ISO 5167-2, *Measurement of fluid flow by means of pressure differential devices inserted in circular cross-section conduits running full — Part 2: Orifice plates (ISO 5167-2:2003)*

EN ISO 5167-3, *Measurement of fluid flow by means of pressure differential devices inserted in circular cross-section conduits running full — Part 3: Nozzles and Venturi nozzles (ISO 5167-3:2003)*

EN ISO 5167-4, *Measurement of fluid flow by means of pressure differential devices inserted in circular cross-section conduits running full — Part 4: Venturi tubes (ISO 5167-4:2003)*

ISO 5221, *Air distribution and air diffusion — Rules to methods of measuring air flow rate in an air-handling duct*

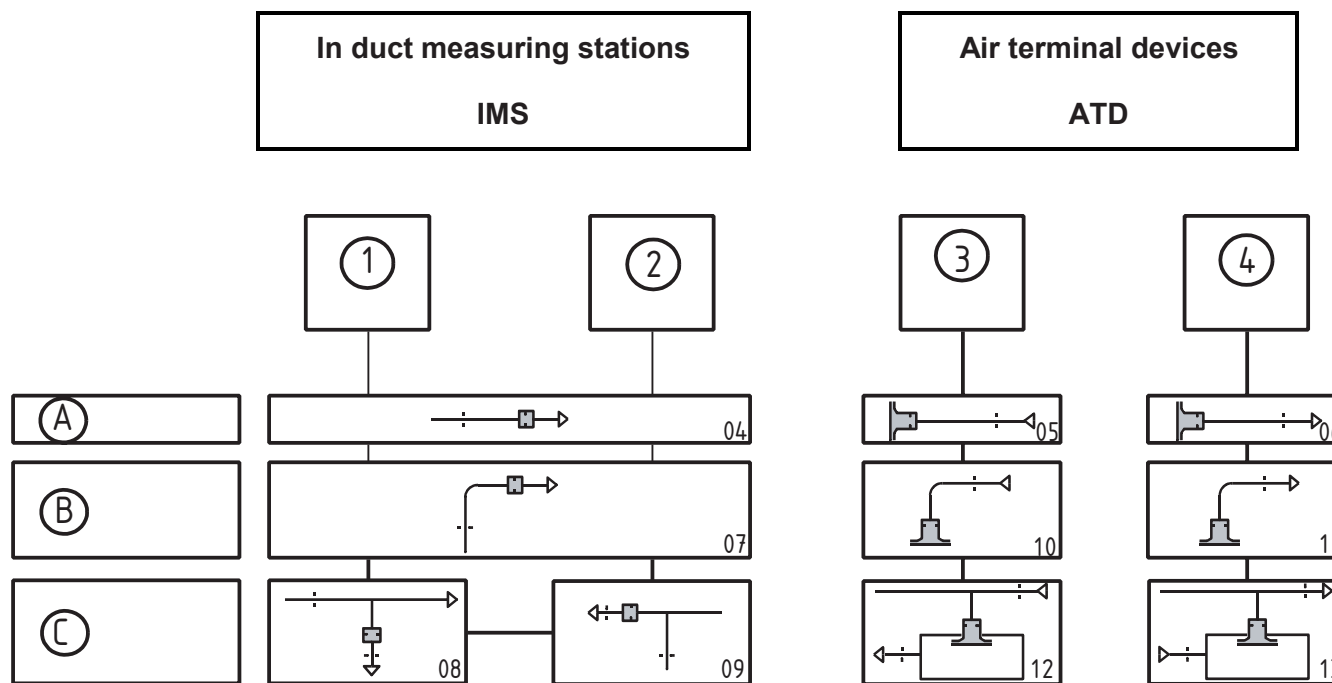

Key

A	Undisturbed situation	1	Supply air	04	See Figure 4	09	See Figure 9
B	90 ° bend	2	Return air	05	See Figure 5	10	See Figure 10
C	T - piece	3	Supply air	06	See Figure 6	11	See Figure 11
		4	Return air	07	See Figure 7	12	See Figure 12
				08	See Figure 8	13	See Figure 13

Figure 1 — Test configurations indicating test devices and test situations

3 Terms, definitions and symbols

3.1 Terms and definitions

For the purposes of this document, the terms and definitions given in EN 12792:2003 and the following apply.

3.1.1

air terminal device [ATD]

component of an installation which is designed for the purpose of achieving the predetermined movement of air into or from a treated space

3.1.2

in-duct measurement station [IMS]

measurement device installed in the ductwork between two pieces of duct

3.1.3

characteristic length

definitive dimension referring to the diameter of a circular duct or to the dimensions L_{c1} or L_{c2} of a rectangular duct (see Figures 2 and 3)

3.1.4

5 % calibration length [L_5]

distance from the device under test in a disturbed situation, within which the measurement error stays within 5 % compared to the calibration curve. This length [L_5] depends on the type of the disturbance and is specified as a function of the characteristic length for all designated types of disturbances defined for each consecutive case

3.1.5

10% calibration length [L_{10}]

distance from the device under test in a disturbed situation, within which the measurement error stays within 10 % compared to the calibration curve. This length [L_{10}] depends on the type of the disturbance and is specified as a function of the characteristic length for all designated types of disturbances defined for each consecutive case

3.1.6

zero-pressure difference method

method to compensate for the effect of the air flow measurement apparatus when measuring air flow rate of induction air or supply/exhaust air

NOTE The method is normally used when it is difficult to measure the air flow rate with sufficient accuracy by other methods due for example to low duct velocity. The method is described in Annex A.

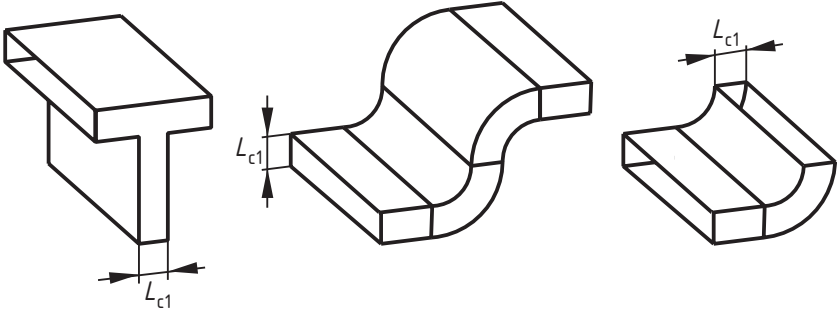

Figure 2 — Rectangular duct disturbances with the characteristic length L_{c1}

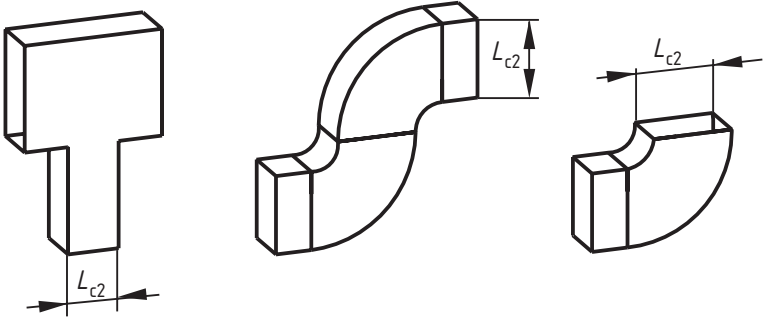

Figure 3 — Rectangular duct disturbances with the characteristic length L_{c2}

3.2 Symbols

For the purposes of this document, the symbols and the suffixes given in Table 1 apply.

Table 1 — Symbols

Symbol	Quantity	Unit
A	Area	m^2
A_D	Cross sectional area of the ATD	m^2
A_{PC}	Cross sectional area of the pressure chamber	m^2
D_e	Equivalent diameter	m
E	Relative error	%
k	Coefficient	-
L	Length	m
L_{c1}	Characteristic length of a rectangular duct	m
L_{c2}	Characteristic length of a rectangular duct	m
n	Exponent	-
p_a	Atmospheric pressure	Pa
p_s	Static gauge pressure	Pa
p_{s1}	Static pressure upstream of the device under test	Pa
p_{s2}	Static pressure downstream of the device under test	Pa
p_{sa}	Absolute static pressure	Pa
Δp	Pressure difference	Pa
Δp_M	Measurement pressure difference	Pa
Δp_s	Static pressure drop over the device under test	Pa
q_v	Measured air flow rate	$\text{l}\cdot\text{s}^{-1}$
v_x	Air velocity in main duct upstream of T-piece	$\text{m}\cdot\text{s}^{-1}$
v_y	Air velocity in side branch of T-piece	$\text{m}\cdot\text{s}^{-1}$
v_z	Air velocity in main duct downstream of T-piece	$\text{m}\cdot\text{s}^{-1}$
β	Output signal	-
ρ_M	Air density during measurement	$\text{kg}\cdot\text{m}^{-3}$

4 Instrumentation

4.1 Air flow rate measurement

4.1.1 The air flow rate shall be measured using instruments in accordance with EN ISO 5167 parts 1 to 4, ISO 5221 or other instruments which will have equivalent calibrated performance.

4.1.2 Air flow meters shall have a minimum calibration accuracy of $\pm 2,5$ % over the whole range.

4.1.3 Flow meters shall be checked at intervals as appropriate but not exceeding 12 months. This check can take the form of one of the following:

- a) a dimensional check for all flow meters not requiring calibration;
- b) a calibration over their full range using the original method employed for the initial calibration of meters calibrated in situ;
- c) a check against a flow meter which meets flow meter specifications according to ISO 5221 and EN ISO 5167 parts 1 to 4 as appropriate.

4.2 Pressure measurement

4.2.1 Pressure in the duct shall be measured by means of a liquid filled, calibrated manometer or any other device conforming to 4.2.2

4.2.2 The resolution shall not be greater than the characteristics listed for the accompanying range of manometers, given in Table 2.

Table 2 — Resolution for the ranges of manometers

Range Pa	Resolution Pa
Up to and including 50	0,1
From 50 to 250	1
From 250 to 500	5,0
Above 500	25,0

4.2.3 The measured value of differential pressure should be greater than 10 % of the range of the measurement device used.

NOTE Example: with a micromanometer in the range 0...1 000 Pa the minimum differential pressure to be measured is 100 Pa.

4.2.4 The uncertainty of calibration standards shall be:

- a) for instruments with the range up to 100 Pa, equal or better than $\pm 0,5$ Pa;
- b) for instruments with the range over 100 Pa, equal or better than $\pm 0,5$ % of reading.

4.3 Temperature measurement

4.3.1 Measurement of temperature shall be, for example, by means of mercury-in-glass thermometers, resistance thermometers or thermo-couples. Instruments shall have a resolution better than 0,5 K and be calibrated to an accuracy of $\pm 0,25$ K.

5 Sampling

5.1 General

5.1.1 In order to achieve a representative result the tests shall be conducted with devices chosen in the following manner from a geometrically similar range as indicated in 5.1.2 and 5.1.3.

5.1.2 For determination of the calibration curve:

- a) if there are from one to three sizes of the measuring device, three samples of each size shall be chosen at random;
- b) if there are more than three sizes, then three samples from each of at least three sizes shall be chosen at random. The chosen sizes shall represent the whole range in which the measuring device to be tested is manufactured and, where practical, shall represent the largest, smallest and mid-range size devices.

5.1.3 For determination of sensitivity to flow disturbances:

- a) if there are one to three sizes of the measuring device, one sample of each size shall be chosen at random;
- b) if there are more than three sizes, then one sample from each of at least three sizes shall be chosen at random. The chosen sizes shall, as well as possible, represent the whole range in which the measuring device to be tested is manufactured and where practical shall represent the largest, smallest and mid-range size devices.

5.2 Integral damper

If a damper is an integral part of the measuring function then the repeatability between the settings of each test sample shall be checked. The direction from which the setting is made is particularly important, due to the possibility of hysteresis, and this should be according to the manufacturer's instructions (see 6.3.4).

6 Determination of the calibration curve

6.1 Principle

The calibration curve is measured by connecting the device to be tested in series with a reference air flow rate meter and an adjustable fan.

6.2 Test installation

6.2.1 The calibration curve for the test samples shall be measured using the test installations shown in Figure 4 for IMS, and in Figure 5 and Figure 6 for ATD, respectively.

6.2.2 Flow straighteners shall be fitted in the upstream test duct at a position $3 D_e$ from the connection to the measuring device to be tested. Alternatively, a straight duct can be used without straighteners if in accordance with EN ISO 5167 parts 1 to 4 as appropriate.

The velocity profile near the upstream connection to the device to be tested shall be uniform to $\pm 10\%$ of the mean value over the test duct cross section, excluding the area within 15 mm of the duct walls (for typical test method see ISO 5221).

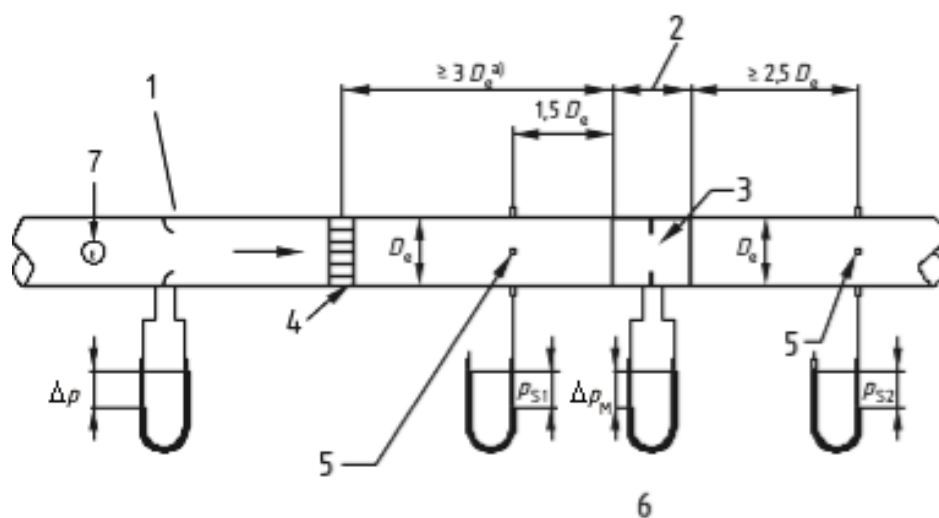

Key

- | | | | |
|---|------------------------------------------------------------------------------------------------|---|---------------------------------------------------------------|
| 1 | reference flow rate measurement device in accordance with EN ISO 5167 parts 1 to 4 or ISO 5221 | 4 | flow straightener in accordance with EN ISO 5167 parts 1 to 4 |
| 2 | total length of unit | 5 | piezometric ring |
| 3 | unit under test | 6 | pressure difference or other output signal |
| | | 7 | temperature measurement |

^{a)} This length to be straight and its cross section uniform and equal to that of the inlet spigot.

Figure 4 — Configurations A1 and A2 – Typical installation for IMS, undisturbed situation

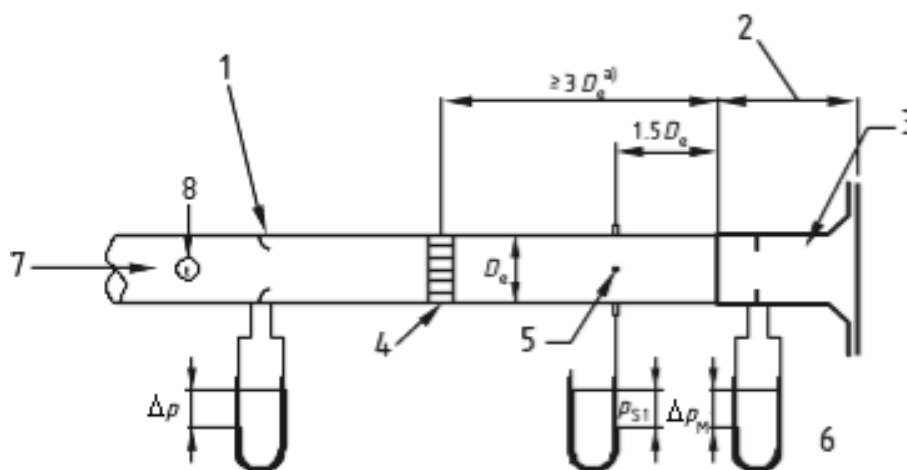

Key

- | | | | |
|---|------------------------------------------------------------------------------------------------|---|--------------------------------------------|
| 1 | reference flow rate measurement device in accordance with EN ISO 5167 parts 1 to 4 or ISO 5221 | 5 | piezometric ring |
| 2 | total length of unit | 6 | pressure difference or other output signal |
| 3 | unit under test | 7 | air flow |
| 4 | Flow straightener in accordance with EN ISO 5167 parts 1 to 4 | 8 | temperature measurement |

^{a)} This length to be straight and its cross section uniform and equal to that of the inlet spigot.

Figure 5 — Configuration A3 – Typical installation for ATD, undisturbed situation

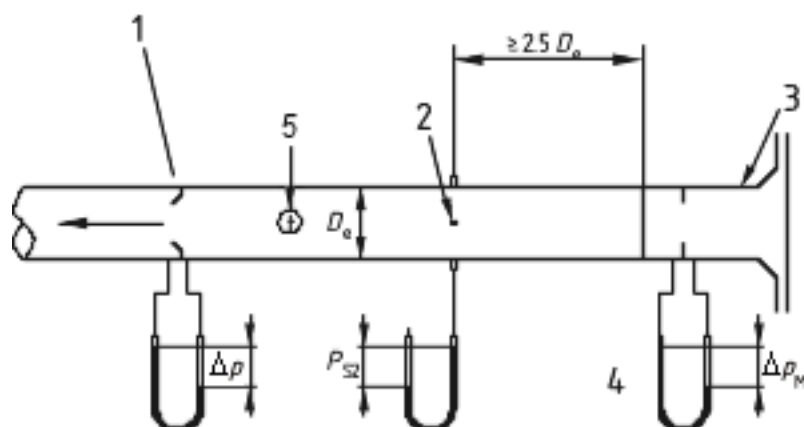

Key

- | | | | |
|---|-------------------------------------------------------------------------------------------------|---|--------------------------------------------|
| 1 | reference flow rate measurement device in accordance with EN ISO 5167 parts 1-2-3-4 or ISO 5221 | 3 | unit under test |
| 2 | piezometric ring | 4 | pressure difference or other output signal |
| | | 5 | temperature measurement |

Figure 6 — Configuration A4 – Typical installation for ATD, Undisturbed situation

6.3 Test procedure

6.3.1 Upstream duct static gauge pressure

The upstream duct static gauge pressure shall be measured by means of four static pressure tappings $1,5 D_e$ from the upstream connection.

The pressure drop for exhaust and supply air terminal devices shall be calculated according to EN 12238 (ISO 5219).

6.3.2 Air flow rates

6.3.2.1 Tests shall be made at the minimum and maximum air flow rates as recommended by the manufacturer and at three approximately equally spaced intermediate values.

6.3.2.2 Starting with the manufacturers recommended minimum air flow rate, increase the flow rate to each of the stages given in 6.3.2.1. At each stage record the output signals according to 8.1.

NOTE When making adjustments to flow rate, if the flow rate rises above the next specified value, reduce it to zero and then slowly increase it to the specified value before a further measurement is taken.

6.3.2.3 Starting with the manufacturers recommended maximum air flow rate, decrease the flow rate to each of the stages given in 6.3.2.1. At each stage record the output signals according to 8.1.

NOTE When making adjustments to flow rate, if the flow rate falls below the next specified value, increase it to the value of the first point tested and then slowly decrease it to the specified value before a further measurement is taken.

6.3.3 Built in damper

If the measuring device has a built-in damper the measurements as described in 6.3.2.1 shall be made in at least the fully open and 50 % open position. If the air flow rates differ from each other by more than 6 %, measurements shall be made at intermediate positions as defined by the manufacturer.

6.3.4 Integral damper

If a damper is an integral part of the measuring function, tests shall be made at a minimum of three different settings representing the whole operating range (minimum, maximum and mid-range). To evaluate repeatability the tests shall be made twice for each sample, following the manufacturer's instructions. If the air flow rates with the same sample and setting differ from each other by more than 5 %, the tests shall be terminated (percentage based on flow difference divided by average flow).

6.3.5 Output signal

The output signal as a function of the air flow rate shall be determined according to the manufacturer's instruction see Figure 14.

If the output signal is a pressure difference, this pressure difference shall be corrected to an air density of $1,20 \text{ kg}\cdot\text{m}^{-3}$ (20°C and $101\,325 \text{ Pa}$), according to the following formula:

$$\Delta p = \Delta p_M \cdot \frac{1,20}{\rho_M}$$

and then normally the calibration curve is of the form:

$$q_V = k \cdot \Delta p^n$$

where the coefficients k and n are determined from the measurements using a best fit method (see Figure 15).

For other output signals β (e.g. voltage) the measured output signals shall be corrected to standard conditions according to the manufacturer's instructions.

Measurements shall be made at sufficient number of points so as to be able to determine the shape of the curve. A minimum number of five measurements is required, approximately equally spaced over the whole air flow rate operating range of the device. The maximum deviation of any individual measurement from the calibration curve shall be less than 5 % for the above characteristic to be used otherwise a new characteristic curve will be required.

7 Test to determine the effect of flow disturbance on measurement accuracy

7.1 Principle

The purpose of the test is to find out the necessary minimum lengths between a flow disturbance and the measuring device to obtain maximum errors in the flow rates within a) $\pm 5 \%$, and b) $\pm 10 \%$, of the calibrated value in the undisturbed case, respectively.

If the maximum difference in flow rate between the calibration curves of the 3 samples of each size is less than 6 %, then only one of each of the calibrated sizes is used to test the sensitivity to flow disturbance (see also 5.1.2). If this difference is more than 6 %, the test shall be terminated.

The deviation from the correct value of a device shall be measured with the device to be tested connected in series with a reference air flow rate meter and an adjustable fan.

7.2 Test procedure

7.2.1 The following items shall be used as flow disturbances:

For circular ducts:

- a) a single 90° bend, see Figure 7.
- b) a T-piece with the branch duct having a cross sectional area of as nearly as practical to half of the main duct cross sectional area.

For rectangular ducts:

Two different bends and T-pieces (see Figures 2 and 3). Tests shall be made with both types.

Where the geometry of the device under test is asymmetrical or a deviation can be suspected when rotating the flow disturbance relative to the measuring device, then the test shall be carried out at three different orientations of the flow disturbance, each one rotated 45° relative to the former orientation.

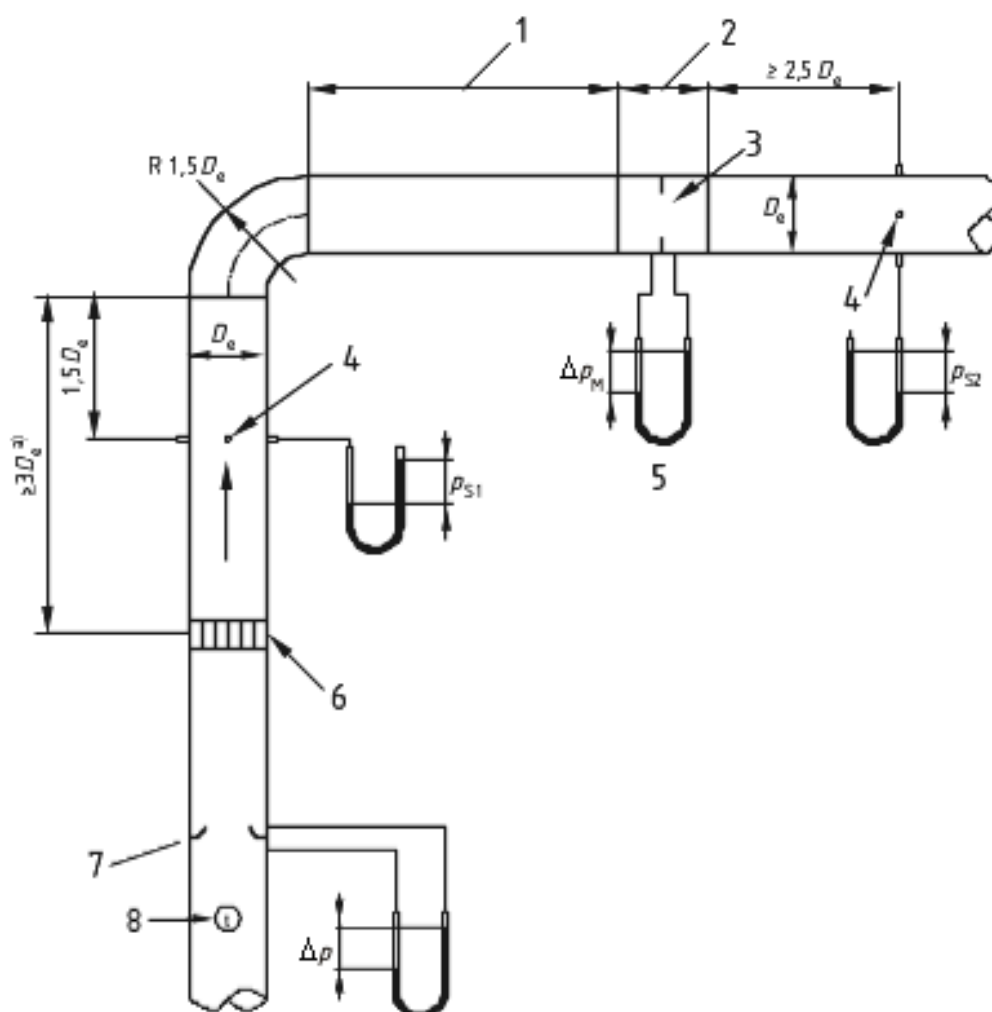

Key

- | | | | |
|---|-------------------------------------------------|---|------------------------------------------------------------------------------------------------|
| 1 | this length to be specified by the manufacturer | 6 | flow straightener in accordance with EN ISO 5167 parts 1 to 4 |
| 2 | total length of unit | 7 | reference flow rate measurement device in accordance with EN ISO 5167 parts 1 to 4 or ISO 5221 |
| 3 | unit under test | 8 | reference flow rate measurement device in accordance with EN ISO 5167 parts 1 to 4 or ISO 5221 |
| 4 | piezometric ring | | temperature measurement |
| 5 | pressure difference or other output signal | | |
- ^{a)} This length to be straight and its cross section uniform and equal to that of the inlet spigot.

Figure 7 — Configurations B1 and B2 – Typical 90° radiused bend for IMS, upstream condition

7.2.2 The test arrangements to measure the sensitivity to the various types of flow disturbances are summarized in Table 3 (see also Figure 1).

Table 3 — Test arrangements

Flow disturbance	In-duct Measurement Stations (IMS)		Air Terminal Devices (ATD)	
	Supply air	Return air	Supply air	Return air
90° bend	B1 (Figure 7)	B2 (Figure 7)	B3 (Figure 10)	B4 (Figure 11)
T-piece	C1 (Figure 8)	C2 (Figure 9)	C3 (Figure 12)	C4 (Figure 13)

NOTE 1 For the tests with T-piece (test arrangements C1 through C4) two reference air flow rate meters are needed. For test arrangements C3 and C4 a zero pressure difference method shall be applied to avoid large errors at small air flow rates, see Annex A.

NOTE 2 Test arrangements B1, B2, B3, C1 and C3 are used to measure the sensitivity to a 90° bend or a T-piece as an upstream disturbance, whereas the test arrangements B4, C2 and C4 are used to measure the sensitivity to downstream flow disturbances.

7.2.3 The measurements for 90° bends shall be performed at the air flow rates corresponding to 50 % and 100 % of the maximum recommended by the manufacturer.

For T-pieces the main duct air velocity (v_x) shall be kept constant at 7 m/s and tests then performed at velocity ratios v_y/v_z approximately equal to 0,3 and 0,7.

Where the damper is an integral part of the measuring function the tests shall be performed for at least three different settings representing the whole operating range. These settings shall be the same as with the undisturbed case.

Where the measuring device includes a built-in damper, tests shall be performed with the same settings as in the undisturbed case.

Where the output signal is a pressure difference, this pressure difference shall be corrected to standard air density in the same way as the undisturbed case (see 6.3.5).

7.2.4 The straight length L of the duct between flow disturbance and the device under test shall be expressed in terms of the characteristic length of the flow disturbance.

For measurements on downstream disturbances it is sufficient to start with the straight duct length $L = 0$ unless otherwise stated by the manufacturer. If the deviation from the calibration values is less than $\pm 5 \%$, then no other duct lengths need to be tested.

When the deviation of the k-value from the calibration curve k-value becomes smaller than 5 %, the measurements can be stopped.

If the difference between the curves of the disturbed and undisturbed (calibration) cases is smaller than 5 %, measurements can be stopped. Otherwise tests shall be made with sufficient number of other duct lengths to determine the lengths L_5 and L_{10} .

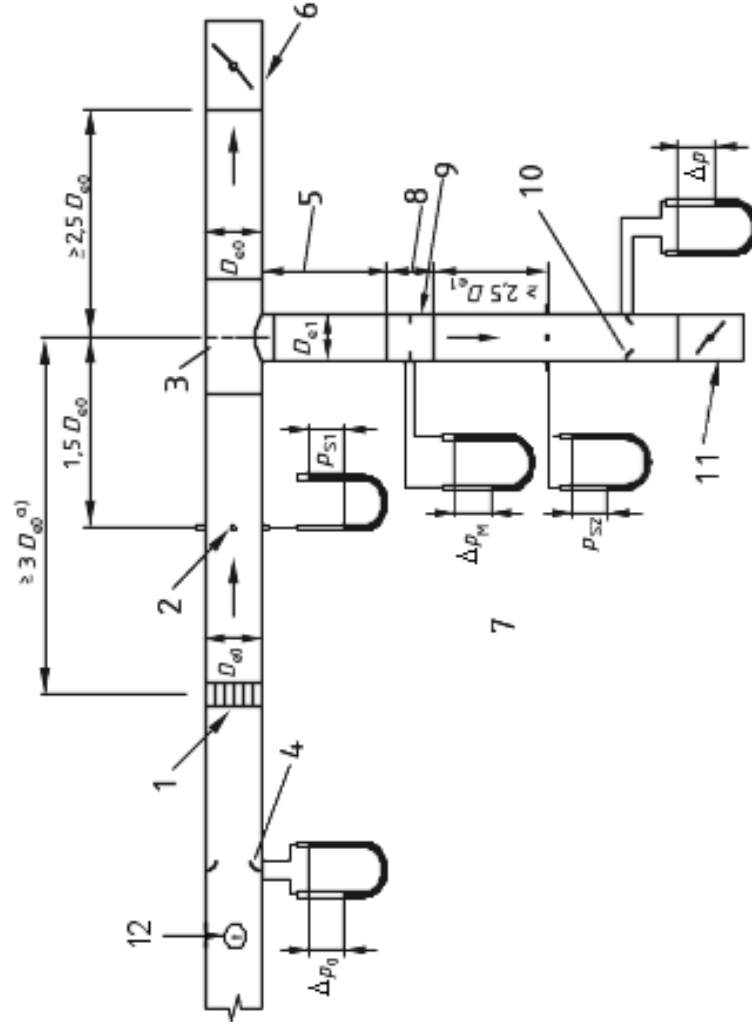

Key

- 1 flow straightener in accordance with EN ISO 5167 parts 1 to 4
 - 2 piezometric ring
 - 3 T-piece specified by the manufacturer
 - 4 flow rate measurement device in accordance with EN ISO 5167-1
 - 5 this length to be specified by the manufacturer
 - 6 auxiliary constant flow rate controller
 - 7 pressure difference or other output signal
 - 8 total length of unit
 - 9 unit under test
 - 10 reference flow rate measurement device in accordance with EN ISO 5167 parts 1 to 4 or ISO 5221
 - 11 damper
 - 12 temperature measurement
- a) This length to be straight and its cross section uniform and equal to that of the inlet spigot.

Figure 8 — Configuration C1 – Typical installation of 'T' connection for IMS

EN 14277:2006 (E)

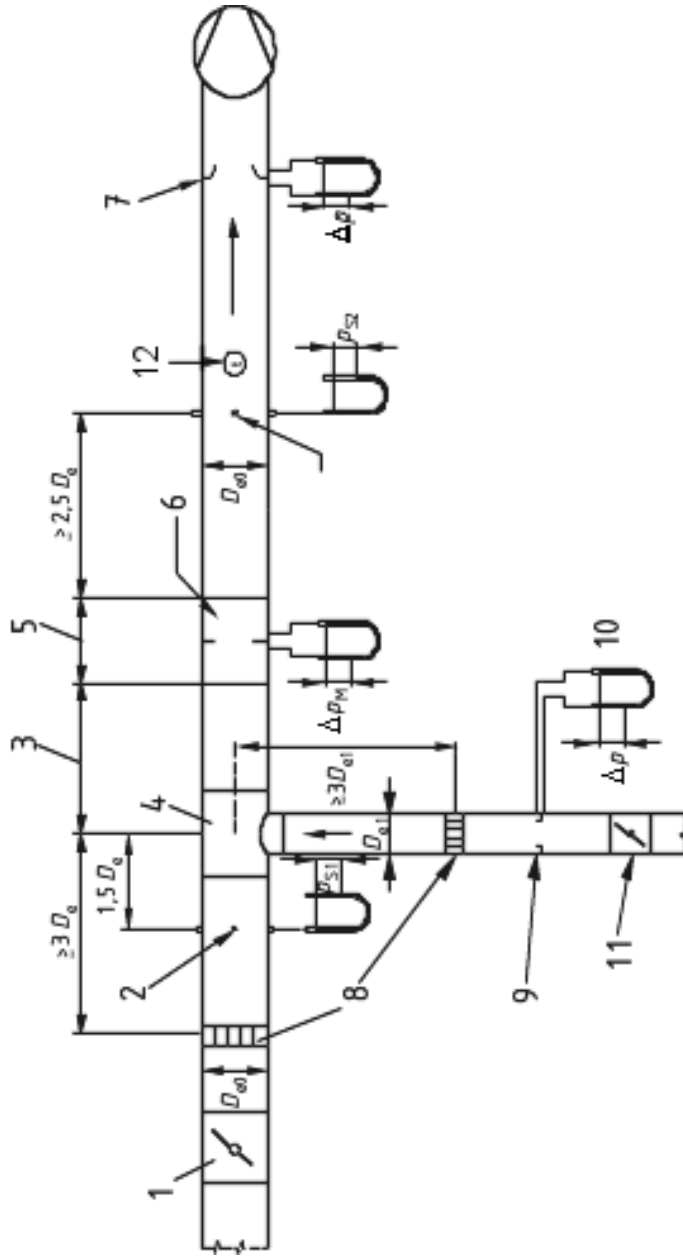

Key

- 1 auxiliary constant flow rate controller
- 2 piezometric ring
- 3 this length to be specified by the manufacturer
- 4 T-piece specified by the manufacturer
- 5 total length of unit
- 6 unit under test
- a) This length to be straight and its cross section uniform and equal to that of the inlet spigot.
- 7 reference flow rate measurement device in accordance with EN ISO 5167 parts 1 to 4 or ISO 5221
- 8 flow straightener in accordance with EN ISO 5167 parts 1 to 4
- 9 flow rate measurement device in accordance with EN ISO 5167 parts 1 to 4 or ISO 5221
- 10 pressure difference or other output signal
- 11 damper
- 12 temperature measurement

Figure 9 — Configuration C2 – Typical installation of 'T' connection for IMS

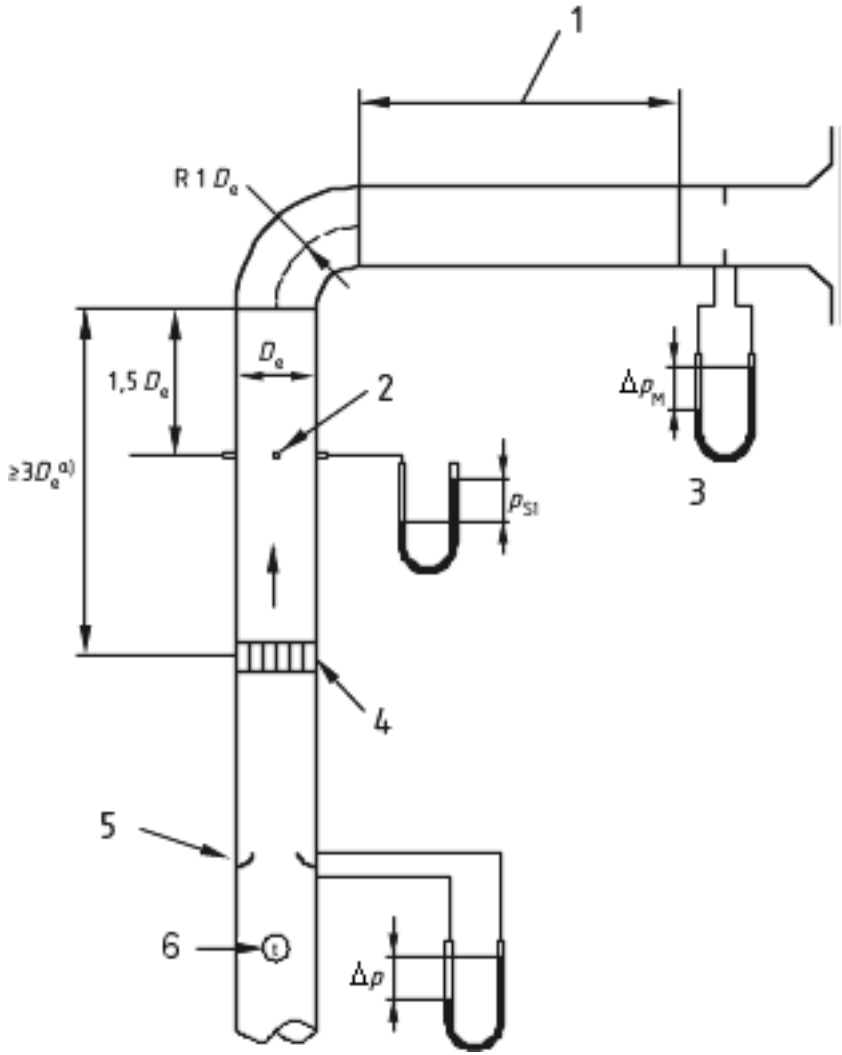

Key

- 1 this length to be specified by the manufacturer
- 2 piezometric ring
- 3 pressure difference or other output signal
- 4 flow straightener in accordance with EN ISO 5167 parts 1 to 4
- 5 reference flow rate measurement device in accordance with EN ISO 5167 parts 1 to 4 or ISO 5221
- 6 temperature measurement

^{a)} This length to be straight and its cross section uniform and equal to that of the inlet spigot.

Figure 10 — Configuration B3 – Typical 90° radiused bend for ATD, upstream condition

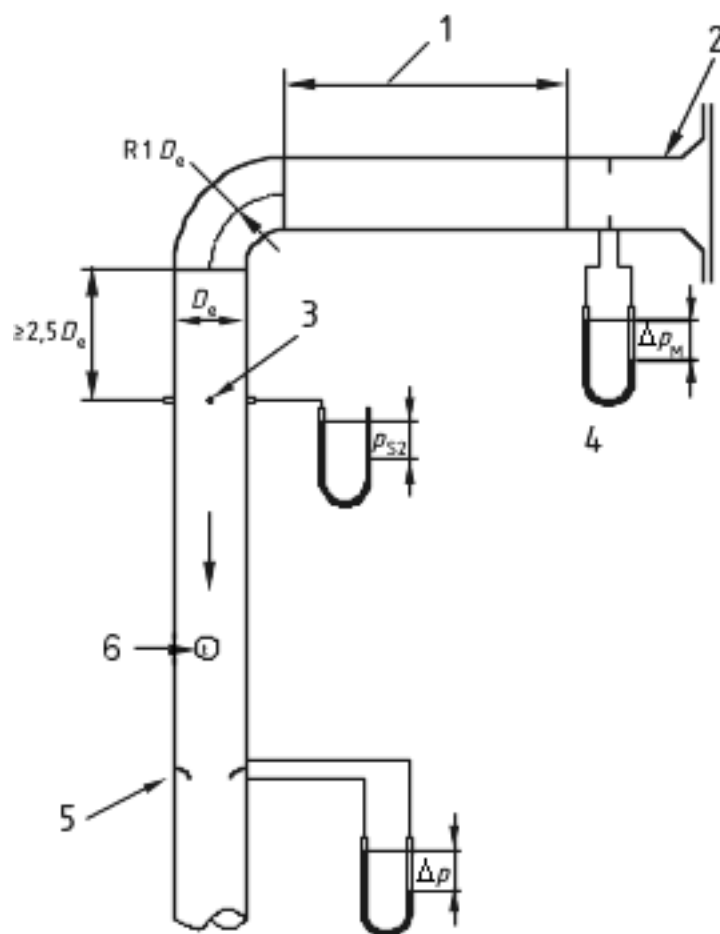

Key

- | | | | |
|---|-------------------------------------------------|---|------------------------------------------------------------------------------------------------|
| 1 | this length to be specified by the manufacturer | 4 | pressure difference or other output signal |
| 2 | unit under test | 5 | reference flow rate measurement device in accordance with EN ISO 5167 parts 1 to 4 or ISO 5221 |
| 3 | piezometric ring | 6 | temperature measurement |

Figure 11 — Configuration B4 – Typical 90° radiused bend for ATD, upstream condition

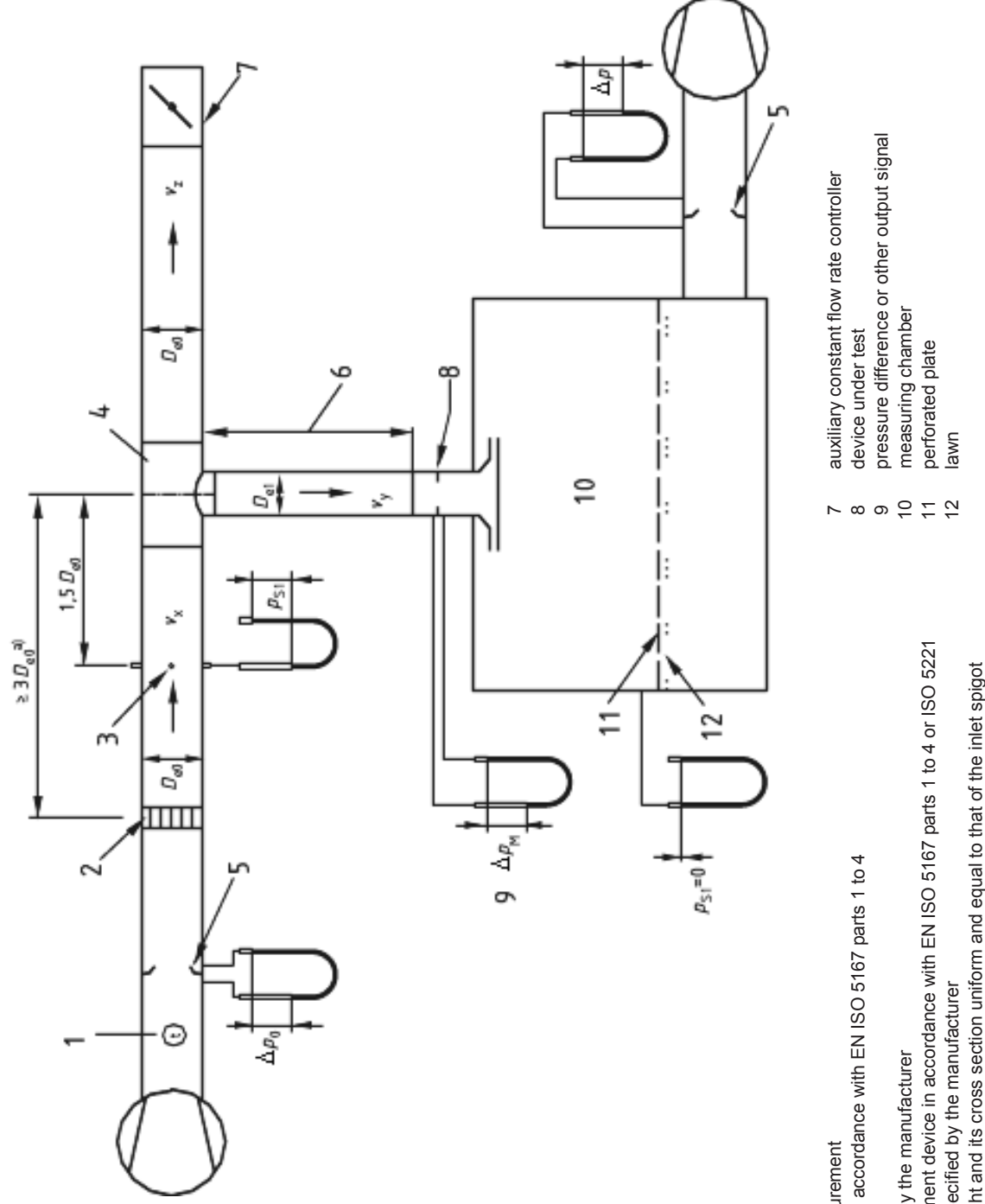

Key

- 1 temperature measurement
- 2 flow straightener in accordance with EN ISO 5167 parts 1 to 4
- 3 piezometric ring
- 4 T-piece specified by the manufacturer
- 5 flow rate measurement device in accordance with EN ISO 5167 parts 1 to 4 or ISO 5221
- 6 this length to be specified by the manufacturer
- 7 auxiliary constant flow rate controller
- 8 device under test
- 9 pressure difference or other output signal
- 10 measuring chamber
- 11 perforated plate
- 12 lawn

^{a)} This length to be straight and its cross section uniform and equal to that of the inlet spigot

Figure 12 — Configuration C3 – Typical installation for ATD, disturbed situation, Upstream 'T' connection – Zero pressure differential method

EN 14277:2006 (E)

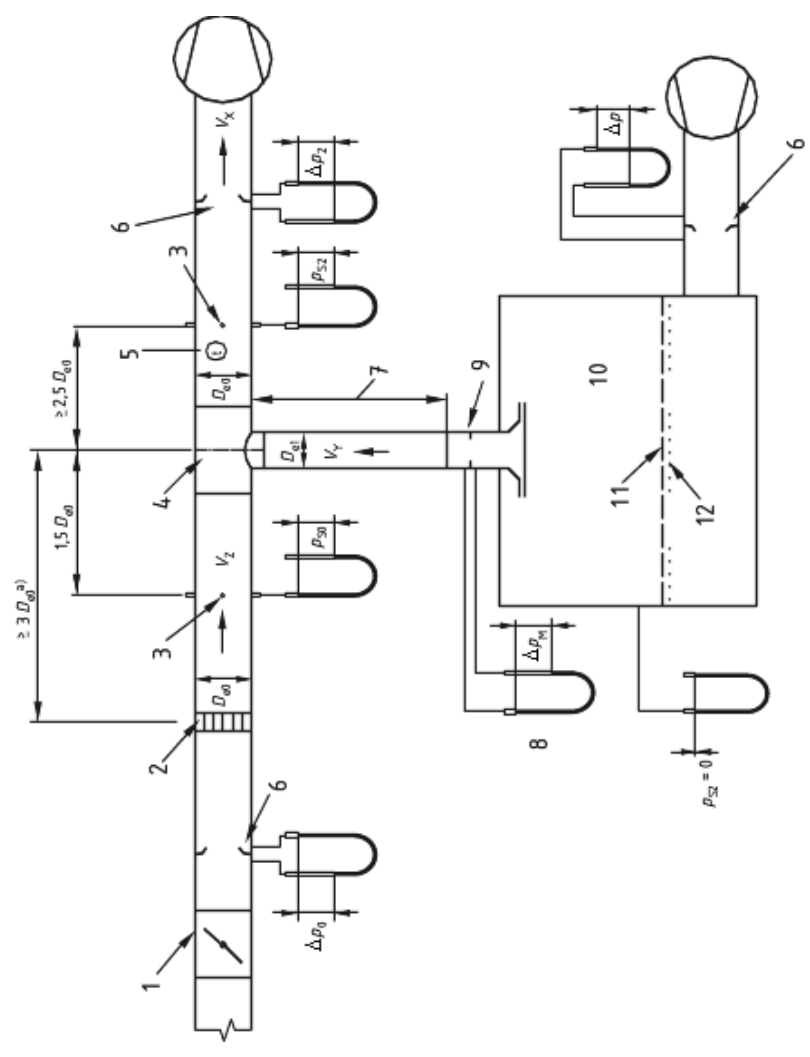

Key

- 1 auxiliary constant flow rate controller
- 2 flow straightener in accordance with EN ISO 5167 parts 1 to 4
- 3 piezometric ring
- 4 T-piece specified by the manufacturer
- 5 temperature measurement
- 6 flow rate measurement device in accordance with EN ISO 5167 parts 1 to 4 or ISO 5221
- 7 this length to be straight and its cross section uniform and equal to that of the inlet spigot.
- 8 pressure difference device under test
- 9 measuring chamber
- 10 perforated plate
- 11 lawn
- 12 pressure difference or other output signal

Figure 13 — Configuration C4 – Typical installation for ATD, disturbed situation, upstream 'T' connection – Zero pressure differential method

8 Test report

8.1 Test results

The calibration values of the tested measuring device shall for each size tested be reported in two graphs showing respectively:

- a) the air flow rate through the measuring device as a function of its output signal (according to the manufacturer's instructions) (see Figure 14);
- b) the pressure drop as a function of the air flow rate for each specimen tested (see Figure 15).

The effect of flow disturbance shall, for each tested combination of disturbance and size of device, be reported in a graph, with the deviation from the calibration curve as a function of the straight duct length between the measuring devices, and the flow disturbance expressed as a function of the characteristic length, with one curve for each velocity. The lengths L_5 and L_{10} shall be indicated (see Figure 16).

8.2 Contents

The test report shall include the following:

- a) name and address of the testing laboratory;
- b) identification number of the test report;
- c) name and address of the organization or person who ordered the test;
- d) purpose of the test;
- e) method of sampling and other circumstances (date and person responsible for sampling);
- f) name and address of manufacturer or supplier of the device tested;
- g) name or other identification marks of the device tested;
- h) description of the device tested;
- i) date of supply of the device tested;
- j) date of the test;
- k) test standard and method;
- l) environmental data prevailing during the test (temperature, air pressure, humidity etc);
- m) identification of the test equipment and instrument used;
- n) any deviation from the test standard;
- o) test results (see 8.1);
- p) inaccuracy or uncertainty of the test results;
- q) date and signature.

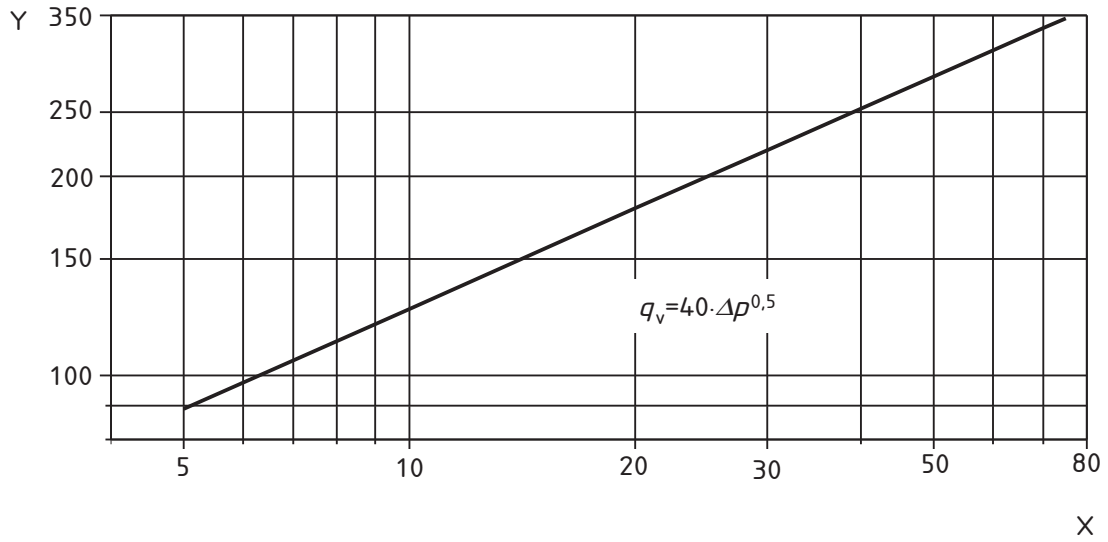

Key

- X output signal (Δp) in Pa
- Y air flow rate (q_v) in l/s

Figure 14 — Air flow rate as a function of output signal

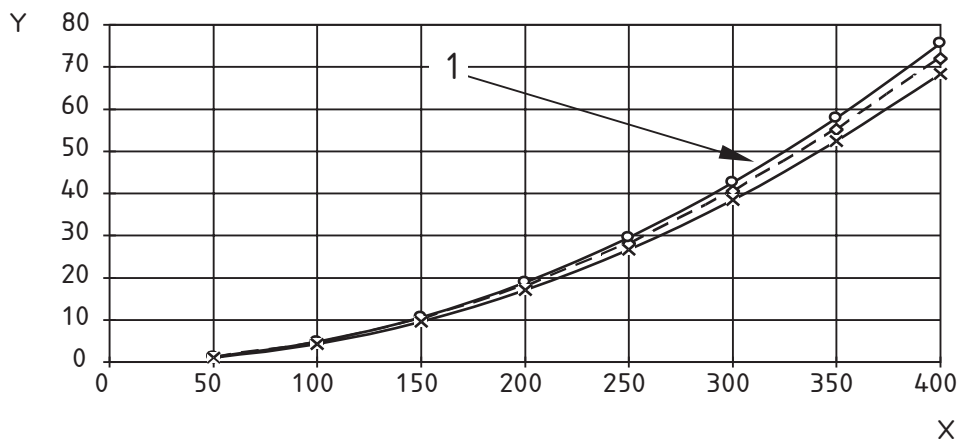

Key

- X air flow rate (q_v) in l/s
- Y output signal (Δp) in Pa
- 1 specimen No. 1, 2 and 3

Figure 15 — Pressure drop as a function of air flow rate

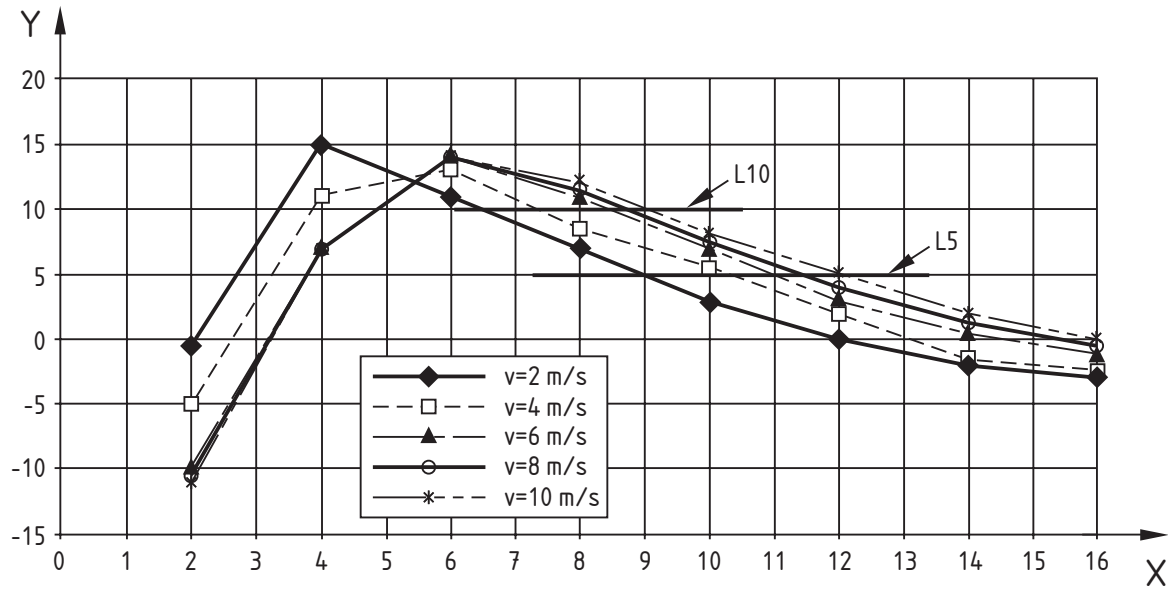
**Key**

X relative length of the straight duct L/L_C (or: L/D_e)

Y relative error, E

Figure 16 — Relative error as a function of the length of the straight duct

Annex A (normative)

Zero-pressure difference method - Principle

The principle of the zero-pressure difference method is to compensate the pressure loss caused by the measurement of an air flow, e.g. induction air flow rate, by means of keeping the pressure difference of the compensation system zero compared with the ambient pressure with the help of a fan. The compensation system consists normally of a chamber, an air flow rate measurement apparatus and a fan. Figure 12 and Figure 13 show a typical zero-pressure difference measurement and compensation system. It is very important to eliminate the dynamic pressure when using zero-pressure differential method with mixing ventilation devices.

The cross sections of the chamber shall meet: the criteria given in Table A.1.

Table A.1 — Criteria for chamber cross section

ATD type	Criterion
Supply air device	$A_{PC} > A_D$
Supply air device, radial discharge	$A_{PC} \geq 10 \cdot A_D$
Exhaust	$A_{PC} \geq 10 \cdot A_D$

BSI — British Standards Institution

BSI is the independent national body responsible for preparing British Standards. It presents the UK view on standards in Europe and at the international level. It is incorporated by Royal Charter.

Revisions

British Standards are updated by amendment or revision. Users of British Standards should make sure that they possess the latest amendments or editions.

It is the constant aim of BSI to improve the quality of our products and services. We would be grateful if anyone finding an inaccuracy or ambiguity while using this British Standard would inform the Secretary of the technical committee responsible, the identity of which can be found on the inside front cover.
Tel: +44 (0)20 8996 9000. Fax: +44 (0)20 8996 7400.

BSI offers members an individual updating service called PLUS which ensures that subscribers automatically receive the latest editions of standards.

Buying standards

Orders for all BSI, international and foreign standards publications should be addressed to Customer Services. Tel: +44 (0)20 8996 9001.
Fax: +44 (0)20 8996 7001. Email: orders@bsi-global.com. Standards are also available from the BSI website at <http://www.bsi-global.com>.

In response to orders for international standards, it is BSI policy to supply the BSI implementation of those that have been published as British Standards, unless otherwise requested.

Information on standards

BSI provides a wide range of information on national, European and international standards through its Library and its Technical Help to Exporters Service. Various BSI electronic information services are also available which give details on all its products and services. Contact the Information Centre.
Tel: +44 (0)20 8996 7111. Fax: +44 (0)20 8996 7048. Email: info@bsi-global.com.

Subscribing members of BSI are kept up to date with standards developments and receive substantial discounts on the purchase price of standards. For details of these and other benefits contact Membership Administration.
Tel: +44 (0)20 8996 7002. Fax: +44 (0)20 8996 7001.
Email: membership@bsi-global.com.

Information regarding online access to British Standards via British Standards Online can be found at <http://www.bsi-global.com/bsonline>.

Further information about BSI is available on the BSI website at <http://www.bsi-global.com>.

Copyright

Copyright subsists in all BSI publications. BSI also holds the copyright, in the UK, of the publications of the international standardization bodies. Except as permitted under the Copyright, Designs and Patents Act 1988 no extract may be reproduced, stored in a retrieval system or transmitted in any form or by any means – electronic, photocopying, recording or otherwise – without prior written permission from BSI.

This does not preclude the free use, in the course of implementing the standard, of necessary details such as symbols, and size, type or grade designations. If these details are to be used for any other purpose than implementation then the prior written permission of BSI must be obtained.

Details and advice can be obtained from the Copyright & Licensing Manager.
Tel: +44 (0)20 8996 7070. Fax: +44 (0)20 8996 7553.
Email: copyright@bsi-global.com.