

# Natural stone test methods — Determination of the slip resistance by means of the pendulum tester

The European Standard EN 14231:2003 has the status of a  
British Standard

ICS 73.020; 91.100.15

## National foreword

This British Standard is the official English language version of EN 14231:2003.

The UK participation in its preparation was entrusted to Technical Committee B/545, Natural stone, which has the responsibility to:

- aid enquirers to understand the text;
- present to the responsible international/European committee any enquiries on the interpretation, or proposals for change, and keep the UK interests informed;
- monitor related international and European developments and promulgate them in the UK.

A list of organizations represented on this committee can be obtained on request to its secretary.

### Cross-references

The British Standards which implement international or European publications referred to in this document may be found in the *BSI Catalogue* under the section entitled “International Standards Correspondence Index”, or by using the “Search” facility of the *BSI Electronic Catalogue* or of British Standards Online.

This publication does not purport to include all the necessary provisions of a contract. Users are responsible for its correct application.

**Compliance with a British Standard does not of itself confer immunity from legal obligations.**

This British Standard was published under the authority of the Standards Policy and Strategy Committee on 24 April 2003

### Summary of pages

This document comprises a front cover, an inside front cover, the EN title page, pages 2 to 13 and a back cover.

The BSI copyright date displayed in this document indicates when the document was last issued.

### Amendments issued since publication

Amd. No.	Date	Comments

© BSI 24 April 2003

ISBN 0 580 41680 1

ICS 73.020; 91.100.15

English version

## Natural stone test methods - Determination of the slip resistance by means of the pendulum tester

Méthodes d'essai pour les pierres naturelles -  
Détermination de la résistance à la glissance au moyen du  
pendule de frottement

Prüfverfahren für Naturstein - Bestimmung des  
Gleitwiderstandes mit Hilfe des Pendelprüfgerätes

This European Standard was approved by CEN on 26 May 2002.

CEN members are bound to comply with the CEN/CENELEC Internal Regulations which stipulate the conditions for giving this European Standard the status of a national standard without any alteration. Up-to-date lists and bibliographical references concerning such national standards may be obtained on application to the Management Centre or to any CEN member.

This European Standard exists in three official versions (English, French, German). A version in any other language made by translation under the responsibility of a CEN member into its own language and notified to the Management Centre has the same status as the official versions.

CEN members are the national standards bodies of Austria, Belgium, Czech Republic, Denmark, Finland, France, Germany, Greece, Hungary, Iceland, Ireland, Italy, Luxembourg, Malta, Netherlands, Norway, Portugal, Slovakia, Spain, Sweden, Switzerland and United Kingdom.



EUROPEAN COMMITTEE FOR STANDARDIZATION  
COMITÉ EUROPÉEN DE NORMALISATION  
EUROPÄISCHES KOMITEE FÜR NORMUNG

Management Centre: rue de Stassart, 36 B-1050 Brussels

## Contents

	page
Foreword .....	3
1 Scope.....	5
2 Normative references .....	5
3 Principle .....	5
4 Terms and definitions .....	5
5 Apparatus.....	6
6 Materials.....	9
7 Preparation of the specimens.....	9
7.1 Sampling .....	9
7.2 Dimensions of the test specimens .....	9
8 Test procedure .....	10
8.1 General .....	10
8.2 Test procedure (in dry conditions).....	10
8.3 Test procedure (in wet conditions) .....	10
9 Expression of results.....	11
10 Test report.....	11
Annex A (normative) Calibration of the pendulum friction tester.....	13
A.1 Weighing of components .....	13
A.2 Balancing of the pendulum arm assembly.....	13
A.3 Setting the effective spring tension .....	13
A.4 Setting the pointer stop.....	13

## Foreword

This document (EN 14231:2003) has been prepared by Technical Committee CEN/TC 246, "Natural stones", the secretariat of which is held by UNI.

This European Standard shall be given the status of a national standard, either by publication of an identical text or by endorsement, at the latest by October 2003, and conflicting national standards shall be withdrawn at the latest by October 2003.

This draft standard is one of the series of draft standards for tests on natural stone.

Test methods for natural stone consist of the following:

EN 1925, *Natural stone test methods - Determination of water absorption coefficient by capillarity*

EN 1926, *Natural stone test methods - Determination of compressive strength*

EN 1936, *Natural stone test methods - Determination of real density and apparent density and of total and open porosity*

EN 12370, *Natural stone test methods - Determination of resistance to crystallisation (by total immersion)*

EN 12371, *Natural stone test methods - Determination of frost resistance*

EN 12372, *Natural stone test methods - Determination of flexural strength under concentrated load*

EN 12407, *Natural stone test methods - Petrographic description*

EN 13161, *Natural stone test methods - Determination of flexural strength under constant moment*

EN 13364, *Natural stone test methods - Determination of the breaking load at dowel hole*

EN 13755, *Natural stone test methods - Determination of water absorption at atmospheric pressure*

EN 13919, *Natural stone test methods - Determination of resistance to ageing by SO<sub>2</sub> action in the presence of humidity*

prEN 13373, *Natural stone test methods – Determination of geometric characteristics*

prEN 14066, *Natural stones test methods - Determination of resistance to ageing by thermal shock*

prEN 14147, *Natural stone test methods - Determination of resistance to ageing by salt mist*

prEN 14157, *Natural stone test methods - Determination of the abrasion resistance*

prEN 14158, *Natural stone test methods - Determination of rupture energy*

prEN 14205, *Natural stone test methods - Determination of Knoop hardness*

prEN 14231, *Natural stone test methods - Determination of the slip resistance by means of the pendulum tester*

prEN 14579, *Natural stone test methods - Determination of sound speed propagation*

prEN 14580, *Natural stone test methods - Determination of static elastic modulus*

## EN 14231:2003 (E)

prEN 14581, *Natural stone test methods - Determination of thermal expansion coefficient*

No existing European Standard is superseded.

This European Standard has an Annex A (normative).

According to the CEN/CENELEC Internal Regulations, the national standards organizations of the following countries are bound to implement this European Standard: Austria, Belgium, Czech Republic, Denmark, Finland, France, Germany, Greece, Hungary, Iceland, Ireland, Italy, Luxembourg, Malta, Netherlands, Norway, Portugal, Slovakia, Spain, Sweden, Switzerland and the United Kingdom.

## 1 Scope

This European Standard specifies a test method to determine the slip resistance value of the surface of the exposed face of natural stone elements intended to be used for flooring in buildings.

NOTE 1 If the surface of the exposed face has a roughness measured according to prEN 13373 higher than 1 mm it will be considered as not slippery, without performing the test.

NOTE 2 This method may be used for laboratory measurements or on floors in service.

## 2 Normative references

This European Standard incorporates by dated or undated reference, provisions from other publications. These normative references are cited at the appropriate places in the text and the publications are listed hereafter. For dated references, subsequent amendments to or revisions of any of these publications apply to this European Standard only when incorporated in it by amendment or revision. For undated references the latest edition of the publication referred to applies.

ISO 48, *Rubber, vulcanized or thermoplastics – Determination of hardness (hardness between 10 IRHD and 100 IRHD)*

ISO 4662, *Rubber – Determination of rebound resilience of vulcanizates*

ISO 7619, *Rubber – Determination of indentation hardness by means of pocket hardness meters*

## 3 Principle

The pendulum friction tester incorporates a spring loaded slider made of a standard rubber attached to the end of the pendulum. On swinging the pendulum the frictional force between slider and test surface is measured by the reduction in length of the swing using a calibrated scale.

## 4 Terms and definitions

For the purposes of this European Standard, the following terms and definitions apply:

### 4.1

#### **slip resistance**

is the property of the floor surface to maintain the adhesion of pedestrian footwear.

NOTE Loss of adhesion leads to loss of control by the pedestrian with consequent increase in the risk of falling.

### 4.2

#### **friction**

is the resistance to relative motion between two bodies in contact, in this case the slider and the test specimen or the footwear sole and the trafficked surface. The frictional force is the force acting tangentially in the contact area.

### 4.3

#### **slip resistance value (SRV)**

the pendulum friction tester incorporates a slider manufactured of rubber. It measures the friction between the slider and the test surface and provides a standardised value of the slip resistance. This is called the slip resistance value (SRV) and shall be measured both in dry and wet conditions.

## 5 Apparatus

5.1 The pendulum friction tester shall be manufactured as shown in Figure 1. All bearings and working parts shall be enclosed as far as possible, and all materials used shall be treated to prevent corrosion under wet conditions.

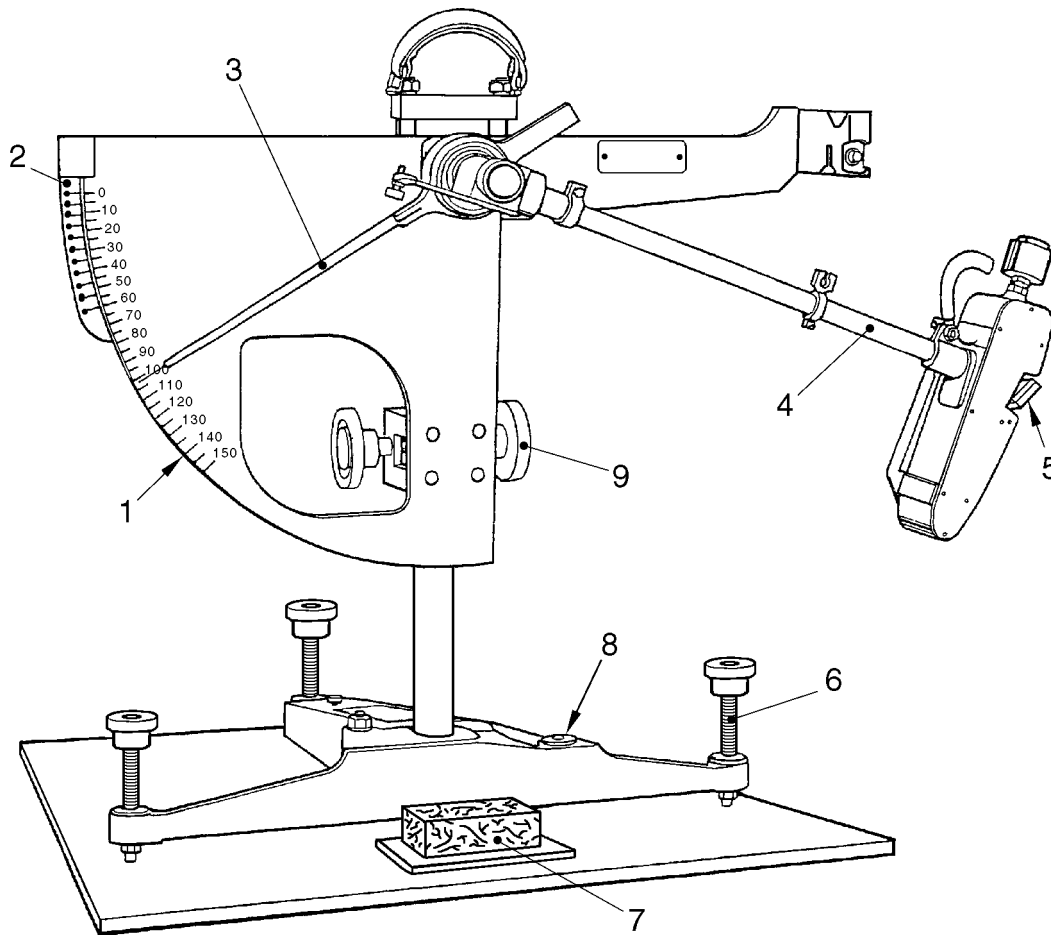

- 1 C scale (126 mm sliding length)
- 2 F scale (76 mm sliding length)
- 3 Pointer
- 4 Pendulum
- 5 Rubber slider
- 6 Levelling screw
- 7 Spirit level
- 8 Vertical adjustment screw
- 9 Test specimen holder

Figure 1 — Pendulum friction tester



5.2 The pendulum friction tester shall have the following features:

- 1) A spring loaded rubber coated slider as specified in clauses 5.4 to 5.10. It shall be mounted on the end of a pendulum arm so that the sliding edge is  $(510 \pm 1)$  mm from the axis of suspension.
- 2) Means of setting the support column of equipment vertical.
- 3) A base of sufficient mass to ensure that the equipment remains stable during the test.
- 4) Means of raising and lowering the axis of suspension of the pendulum arm so that the slider can:
  - i) swing clear of the surface of the specimen; and
  - ii) be set to traverse a surface over a fixed length of  $(126 \pm 1)$  mm when using the wide slider or  $(76 \pm 1)$  mm when using the narrow slider. Gauges with these distances marked are required as shown in Figure 2.

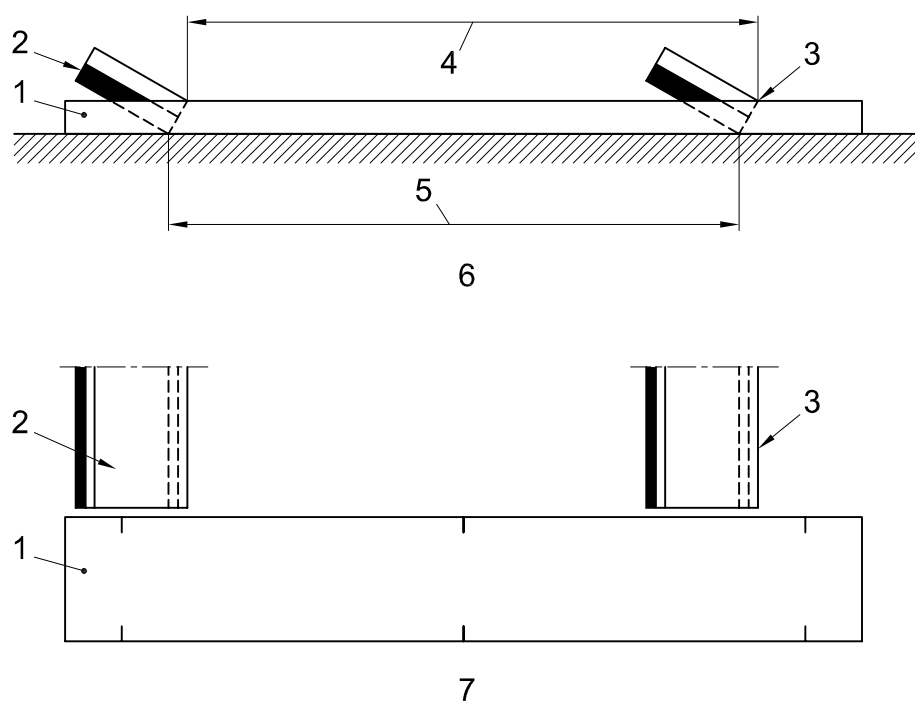

- 1 Gauge
- 2 Slider
- 3 Reference edge
- 4 Sliding length measured
- 5 Actual sliding length
- 6 Side view
- 7 Plan view

**Figure 2 — Sliding length gauge**

- 5) Means of holding and releasing the pendulum arm so that it falls freely from a horizontal position.
- 6) A pointer of nominal length of 300 mm, balanced about the axis of suspension, indicating the position of the pendulum arm throughout its forward swing and moving over the circular scale. The mass of the pointer shall be not more than 85 g.
- 7) The friction in the pointer mechanism shall be adjustable so that, with the pendulum arm swinging freely from a horizontal position, the outward tip of the pointer may be brought to rest on the forward swing of the arm at a point  $(10 \pm 1)$  mm below the horizontal. This is the 0 reading.

8) A circular scale (C scale), calibrated for a sliding length of 126 mm on a flat surface, marked from 0 to 150 at intervals of five units.

A circular scale (F scale) calibrated for a sliding length of 76 mm on a flat surface and marked from 0 to 1 at intervals of 0,05.

5.3 The mass of the pendulum arm, including the slider, shall be  $(1,50 \pm 0,03)$  kg. The centre of gravity shall be on the axis of the arm at a distance of  $(410 \pm 5)$  mm from the axis of suspension.

5.4 The wide slider shall consist of a rubber pad  $(76,2 \pm 0,5)$  mm wide,  $(25,4 \pm 1,0)$  mm long (in the direction of swing) and  $(64,0 \pm 0,5)$  mm thick, the combined mass of slider and base shall be  $(32 \pm 5)$  g.

The narrow slider shall consist of a rubber pad  $(31,8 \pm 0,5)$  mm wide,  $(25,4 \pm 1,0)$  mm long and  $(64,0 \pm 0,5)$  mm thick; the combined mass of the slider and base shall be  $(20 \pm 5)$  g.

5.5 The slider shall be held on a rigid base with a centre pivoting axis which shall be mounted on the end of the pendulum arm in such a way that, when the arm is at the lowest point of its swing with the trailing edge of the slider in contact with the test surface, the plane of the slider is angled at  $(26 \pm 3)$  degrees to the horizontal. In this configuration the slider can turn about its axis without obstruction to follow unevenness of the surface of the test surface as the pendulum swings.

5.6 The slider shall be spring-loaded against the test surface. When calibrated, the static force on the slider as set by the equipment calibration procedure shall be  $(22,2 \pm 0,5)$  N in its median position. The change in the static force on the slider shall be not greater than 0,2 N per millimetre deflection of the slider.

5.7 The initial resilience and hardness of the slider shall comply with Table 1. The compliance shall be proved with a certificate of conformity including the name of the manufacturer and date of manufacture. A slider shall be discarded when the IRHD value measured in accordance with ISO 7619 fails to comply with the requirements of the Table 1 or not later than three years after manufacture.

**Table 1 — Properties of the slider rubber at 20 °C**

Resilience (%) <sup>a)</sup>	66 to 73
Hardness (IRHD) <sup>b)</sup>	53 to 65
<sup>a)</sup> Lüpke rebound test in accordance with ISO 4662 <sup>b)</sup> International Rubber Hardness Degrees in accordance with ISO 48	

5.8 The edges of the slider shall be square and clean-cut, and the rubber free from contamination by, for example, abrasive or oil. The slider shall be stored in the dark at a temperature in the range 5°C to 20°C.

5.9 Before using a new slider it shall be conditioned to produce a minimum width of striking edge of 1 mm as shown in Figure 3.

This shall be achieved by setting up the tester and carrying out 5 swings on a dry surface with a friction value above 40 on the C scale followed by a further 20 swings on the same surface after wetting.

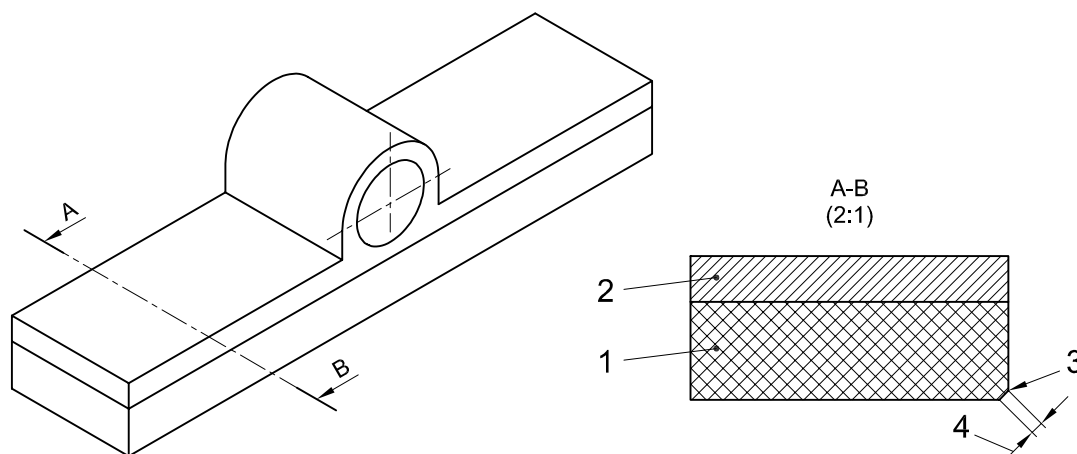

- 1 Rubber slider
- 2 Aluminium backing
- 3 Striking edge
- 4 Worn width (between 1 and 3 mm)

**Figure 3 — Slider assembly illustrating the worn width of the striking edge**

**5.10** The slider shall be discarded when the width of the striking edge as shown in Figure 3 exceeds 3 mm or when it becomes excessively scored or burred. The slider can be reversed to expose a new edge, which will need to be conditioned.

**5.11** The apparatus shall be recalibrated at least annually.

The calibration procedure is described in Annex A.

## 6 Materials

Distilled or deionised water at  $(20 \pm 5)^\circ\text{C}$  in a container for wetting the surfaces of the test specimen and slider, in case of testing in wet conditions.

## 7 Preparation of the specimens

### 7.1 Sampling

**7.1.1** For laboratory measurements, the sampling is not the responsibility of the test laboratory except where specially requested. At least six specimens, which are considered representative both of the stone being tested, and the surface finish shall be selected.

**7.1.2** For measurements in floors in service at least six areas, which are considered representative of the floor surface being tested, shall be selected.

### 7.2 Dimensions of the test specimens

The test specimens shall be a whole product or a cut piece, incorporating the upper face of the unit. Each specimen shall permit a test area of  $136 \text{ mm} \times 86 \text{ mm}$ . This area shall be tested using the 76 mm wide slider over a swept length of 126 mm, readings being taken on the C scale.

If this is not possible, a smaller test area of  $42 \text{ mm} \times 86 \text{ mm}$  may be selected and tested using the 31,8 mm wide slider over a swept length of 76 mm, readings being taken on the F scale.

## 8 Test procedure

### 8.1 General

**8.1.1** For laboratory measurements keep the friction tester equipment, slider and the specimens in a room at a temperature of  $(20 \pm 5)^\circ\text{C}$  for at least 2 hours before the test begins.

Select the appropriate slider and test scale for the size of the specimen.

**8.1.2** For measurements on floors in service brush the test surface free of loose particles and flush it with water. Measure the temperature of the test surface and slider to the nearest  $1^\circ\text{C}$ . The test cannot be carried out if the surface temperature is outside the range  $5^\circ\text{C}$  to  $40^\circ\text{C}$ .

**8.1.3** Place the friction tester upon a firm level surface and adjust the levelling screws so that the pendulum support column is vertical. Then raise the axis of suspension of the pendulum so that the arm swings freely, and adjust the friction in the pointer mechanism so that when the pendulum arm and pointer are released from the right-hand horizontal position the pointer comes to rest at zero position on the test scale.

**8.1.4** Rigidly locate the test specimen with its longer dimension lying in the track of the pendulum, and centrally with respect to the rubber slider and to the axis of the suspension of the pendulum. Ensure that the track of the slider is parallel to the long axis of the specimen across the sliding distance.

**8.1.5** Adjust the height of the pendulum arm so that in traversing the specimen the rubber slider is in contact with it over the whole width of the slider and over the specified swept length.

### 8.2 Test procedure (in dry conditions)

**8.2.1** Bring the pointer round to its stop. Release the pendulum arm by pressing the release button and catch it on the return swing before the slider re-strikes the test surface. Record the reading indicated on the graduated scale. Return the arm and pointer to its start position, keeping the slider clear of the surface by means of the mechanism provided.

**8.2.2** Repeat 8.2.1 in the same orientation until five successive readings (on the C scale) do not differ by more than three units.

NOTE If the F scale is used the five successive readings shall not differ by more than 0,03.

**8.2.3** Raise the head of the tester so that it swings clear of the surface and check the free swing for zero error. If the zero has drifted by more than one unit then repeat steps 8.1.3 to 8.2.2.

**8.2.4** For laboratory measurements relocate the specimen after rotating through  $180^\circ$  and repeat steps 8.1.4 to 8.2.3.

**8.2.5** For measurements on floors in service rotate the friction tester through  $180^\circ$  and repeat steps 8.1.3 to 8.2.3.

### 8.3 Test procedure (in wet conditions)

**8.3.1** For laboratory measurements immediately prior to testing immerse the specimens in water at  $(20 \pm 5)^\circ\text{C}$  for at least 2 hours.

**8.3.2** Prior to each swing of the pendulum, thoroughly wet the test surface and slider with distilled or deionised water at  $(20 \pm 5)^\circ\text{C}$  temperature.

**8.3.3** Repeat steps 8.1.3 to 8.2.2 on previously untested areas.

**8.3.4** Raise the head of the tester so that it swings clear of the surface and check the free swing for zero error. If the zero has drifted by more than one unit then repeat steps 8.3.2 to 8.3.3

**8.3.5** For laboratory measurements relocate the specimen after rotating through  $180^\circ$  and repeat steps 8.1.4 to 8.1.5 and steps 8.3.2 to 8.3.4.

**8.3.6** For measurements on floors in service rotate the friction tester through 180° and repeat steps 8.1.3 to 8.1.5 and steps 8.3.2 to 8.3.4.

## 9 Expression of results

For each specimen or each test area calculate the mean value of each set of five recorded readings measured in opposite directions and both in dry and wet test conditions.

For measurements made with the wide slider calculate the pendulum value of each specimen in dry test condition as the mean of the two recorded mean values measured in opposite directions to the nearest 1 unit on the C scale.

For measurements made with the narrow slider calculate the pendulum value of each specimen as the mean of the two recorded mean values measured in opposite directions to the nearest 0,01 unit on the F scale multiplied by 100 and by a correction factor of 1,2 for scale graduation and the effect of the different swept length.

Repeat this procedure for the results obtained in wet test condition.

For measurements made on floors in service correct the measured values for temperature, using the graph given in Figure 4.

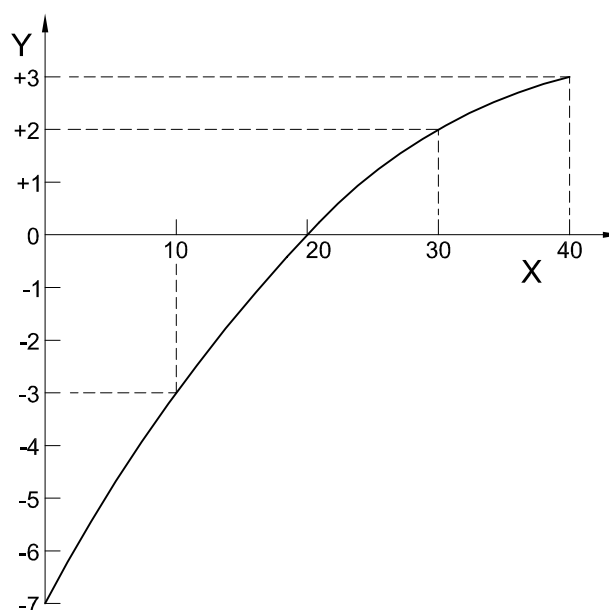

X Test temperature °C  
Y Factor to be added to correct to 20°C

**Figure 4 — Temperature correction to allow for changes in resilience of the slider rubber**

The slip resistance value in dry condition (SRV "dry") is the mean pendulum value obtained on the six specimens in dry test condition.

The slip resistance value in wet condition (SRV "wet") is the mean pendulum value obtained on the six specimens in wet test condition.

## 10 Test report

The test report shall include the following information:

- unique identification number of the report ;
- the number, title and date of issue of this European standard;

## EN 14231:2003 (E)

- c) the name and address of the test laboratory and the address where the test was carried out, if different from the test laboratory;
- d) the name and address of the client;
- e) it is the responsibility of the client to supply the following information:
  - the petrographic name of the stone;
  - the commercial name of the stone;
  - the country and region of extraction;
  - the name of the supplier;
  - the direction of any existing plane of anisotropy (if relevant to the test) to be clearly indicated on the sample or on each specimen by means of two parallel lines;
  - the name of the person or organization which carried out the sampling;
  - the surface finish of the specimens (if relevant to the test);
- f) the date of delivery of the sample or of the specimens;
- g) the date when the specimens were prepared (if relevant) and the date of testing;
- h) the number of specimens in the sample;
- i) the dimensions of the specimens;
- j) for each test specimen the mean pendulum value both in dry and wet test conditions;
- k) the slip resistance value (SRV "dry") in dry test condition;
- l) the slip resistance value (SRV "wet") in wet test condition;
- m) all deviations from the standard and their justification;
- n) remarks.

The test report shall contain the signature(s) and role(s) of those responsible(s) for the testing and the date of issue of the report. It shall also state that the report shall not be partially reproduced without the written consent of the test laboratory.

## Annex A (normative) Calibration of the pendulum friction tester

### A.1 Weighing of components

- A.1.1 Remove the pendulum arm and pointer.
- A.1.2 Weigh the pointer to the nearest 1 g, measure its length to the nearest 1 mm and ensure that it is straight.
- A.1.3 Weigh the complete pendulum arm assembly to the nearest 5 g.

### A.2 Balancing of the pendulum arm assembly

- A.2.1 Balance the pendulum arm on a knife edge with the adapter nut in its extreme position.
- A.2.2 With the slider assembly in a horizontal position, adjust the counterweight in the trailing edge of the assembly until it is balanced about the pendulum arm.
- A.2.3 Measure the distance from the centre of oscillation to the centre of gravity of the pendulum arm assembly to the nearest 1 mm.

### A.3 Setting the effective spring tension

- A.3.1 Remove the small retaining plate covering the slider lifting handle.
- A.3.2 With the slider assembly foot inverted, suspend a load equivalent to 22,2 N from the spindle.
- A.3.3 Adjust the spring tension until the lifting handle is brought to its median position. The complete movement of the slider (parallel to the pendulum arm) when using the lifting handle shall be at least 6,5 mm.
- A.3.4 Check the change in force on the slider by the addition and subtraction of weights to the applied load, and measuring the deflection of the slider for each increment of load (Suitable increments are about 20 g).
- A.3.5 The complete movement of the slider (deflection) shall be at least 11 mm.

### A.4 Setting the pointer stop

- A.4.1 Adjust the pointer stop until the centreline of the pointer is parallel with the pendulum arm in a vertical position, with the friction tester assembled and levelled.

---

---

## BSI — British Standards Institution

BSI is the independent national body responsible for preparing British Standards. It presents the UK view on standards in Europe and at the international level. It is incorporated by Royal Charter.

### Revisions

British Standards are updated by amendment or revision. Users of British Standards should make sure that they possess the latest amendments or editions.

It is the constant aim of BSI to improve the quality of our products and services. We would be grateful if anyone finding an inaccuracy or ambiguity while using this British Standard would inform the Secretary of the technical committee responsible, the identity of which can be found on the inside front cover.  
Tel: +44 (0)20 8996 9000. Fax: +44 (0)20 8996 7400.

BSI offers members an individual updating service called PLUS which ensures that subscribers automatically receive the latest editions of standards.

### Buying standards

Orders for all BSI, international and foreign standards publications should be addressed to Customer Services. Tel: +44 (0)20 8996 9001.  
Fax: +44 (0)20 8996 7001. Email: [orders@bsi-global.com](mailto:orders@bsi-global.com). Standards are also available from the BSI website at <http://www.bsi-global.com>.

In response to orders for international standards, it is BSI policy to supply the BSI implementation of those that have been published as British Standards, unless otherwise requested.

### Information on standards

BSI provides a wide range of information on national, European and international standards through its Library and its Technical Help to Exporters Service. Various BSI electronic information services are also available which give details on all its products and services. Contact the Information Centre.  
Tel: +44 (0)20 8996 7111. Fax: +44 (0)20 8996 7048. Email: [info@bsi-global.com](mailto:info@bsi-global.com).

Subscribing members of BSI are kept up to date with standards developments and receive substantial discounts on the purchase price of standards. For details of these and other benefits contact Membership Administration.  
Tel: +44 (0)20 8996 7002. Fax: +44 (0)20 8996 7001.  
Email: [membership@bsi-global.com](mailto:membership@bsi-global.com).

Information regarding online access to British Standards via British Standards Online can be found at <http://www.bsi-global.com/bsonline>.

Further information about BSI is available on the BSI website at <http://www.bsi-global.com>.

### Copyright

Copyright subsists in all BSI publications. BSI also holds the copyright, in the UK, of the publications of the international standardization bodies. Except as permitted under the Copyright, Designs and Patents Act 1988 no extract may be reproduced, stored in a retrieval system or transmitted in any form or by any means – electronic, photocopying, recording or otherwise – without prior written permission from BSI.

This does not preclude the free use, in the course of implementing the standard, of necessary details such as symbols, and size, type or grade designations. If these details are to be used for any other purpose than implementation then the prior written permission of BSI must be obtained.

Details and advice can be obtained from the Copyright & Licensing Manager.  
Tel: +44 (0)20 8996 7070. Fax: +44 (0)20 8996 7553.  
Email: [copyright@bsi-global.com](mailto:copyright@bsi-global.com).