

# Cold applied joint sealants —

## Part 7: Test method for the determination of the resistance to flame

The European Standard EN 14187-7:2003 has the status of a  
British Standard

ICS 13.220.50; 93.080.20

## National foreword

This British Standard is the official English language version of EN 14187-7:2003.

The UK participation in its preparation was entrusted by Technical Committee B/510, Road materials, to Subcommittee B/510/3, Materials for concrete roads, which has the responsibility to:

- aid enquirers to understand the text;
- present to the responsible international/European committee any enquiries on the interpretation, or proposals for change, and keep the UK interests informed;
- monitor related international and European developments and promulgate them in the UK.

A list of organizations represented on this subcommittee can be obtained on request to its secretary.

### Cross-references

The British Standards which implement international or European publications referred to in this document may be found in the *BSI Catalogue* under the section entitled “International Standards Correspondence Index”, or by using the “Search” facility of the *BSI Electronic Catalogue* or of British Standards Online.

This publication does not purport to include all the necessary provisions of a contract. Users are responsible for its correct application.

**Compliance with a British Standard does not of itself confer immunity from legal obligations.**

This British Standard, was published under the authority of the Standards Policy and Strategy Committee on 19 June 2003

### Summary of pages

This document comprises a front cover, an inside front cover, the EN title page, pages 2 to 7 and a back cover.

The BSI copyright date displayed in this document indicates when the document was last issued.

### Amendments issued since publication

Amd. No.	Date	Comments

© BSI 19 June 2003

ISBN 0 580 42095 7

EUROPEAN STANDARD

EN 14187-7

NORME EUROPÉENNE

EUROPÄISCHE NORM

June 2003

ICS 13.220.50; 93.080.20

English version

## Cold applied joint sealants - Part 7: Test method for the determination of the resistance to flame

Mastics pour joints appliqués à froid - Partie 7: Méthodes d'essai pour la détermination de la résistance à la flamme

Kalt verarbeitbare Fugenmassen - Teil 7: Prüfverfahren zur Bestimmung des Widerstandes gegen Flammen

This European Standard was approved by CEN on 25 March 2003.

CEN members are bound to comply with the CEN/CENELEC Internal Regulations which stipulate the conditions for giving this European Standard the status of a national standard without any alteration. Up-to-date lists and bibliographical references concerning such national standards may be obtained on application to the Management Centre or to any CEN member.

This European Standard exists in three official versions (English, French, German). A version in any other language made by translation under the responsibility of a CEN member into its own language and notified to the Management Centre has the same status as the official versions.

CEN members are the national standards bodies of Austria, Belgium, Czech Republic, Denmark, Finland, France, Germany, Greece, Hungary, Iceland, Ireland, Italy, Luxembourg, Malta, Netherlands, Norway, Portugal, Slovakia, Spain, Sweden, Switzerland and United Kingdom.



EUROPEAN COMMITTEE FOR STANDARDIZATION  
COMITÉ EUROPÉEN DE NORMALISATION  
EUROPÄISCHES KOMITEE FÜR NORMUNG

Management Centre: rue de Stassart, 36 B-1050 Brussels

# Contents

page

Foreword.....	3
1 <b>Scope</b> .....	4
2 <b>Normative references</b> .....	4
3 <b>Terms and definitions</b> .....	4
4 <b>Principle</b> .....	4
5 <b>Apparatus and materials</b> .....	4
6 <b>Preparation of test specimens</b> .....	4
7 <b>Procedure</b> .....	5
8 <b>Test report</b> .....	7

## Foreword

This document (EN 14187-7:2003) has been prepared by Technical Committee CEN/TC 227 "Road materials", the secretariat of which is held by DIN.

This European Standard shall be given the status of a national standard, either by publication of an identical text or by endorsement, at the latest by December 2003, and conflicting national standards shall be withdrawn at the latest by March 2005.

This European Standard is one of a series of standards as listed below:

EN 14187-1, *Cold applied joint sealants — Part 1: Test method for the determination of the rate of cure.*

EN 14187-2, *Cold applied joint sealants — Part 2: Test method for the determination of tack free time.*

EN 14187-3, *Cold applied joint sealants — Part 3: Test method for the determination of self-levelling properties.*

EN 14187-4, *Cold applied joint sealants — Part 4: Test method for the determination of the change in mass and volume after immersion in test fuel.*

EN 14187-5, *Cold applied joint sealants — Part 5: Test method for the determination of the resistance to hydrolysis.*

EN 14187-6, *Cold applied joint sealants — Part 6: Test method for the determination of the adhesion/cohesion properties after immersion in chemical liquids.*

EN 14187-7, *Cold applied joint sealants — Part 7: Test method for the determination of the resistance to flame.*

EN 14187-8, *Cold applied joint sealants — Part 8: Test method for the determination of the artificial weathering by UV-irradiation.*

prEN 14187-9, *Cold applied joint sealants — Part 9: Function test.*<sup>1)</sup>

No existing European Standard is superseded.

**WARNING — This test should be carried out under suitable environmental conditions to provide adequate protection to personnel against the risk of fire, inhalation of smoke and/or toxic products of combustion.**

According to the CEN/CENELEC Internal Regulations, the national standards organizations of the following countries are bound to implement this European Standard: Austria, Belgium, Czech Republic, Denmark, Finland, France, Germany, Greece, Hungary, Iceland, Ireland, Italy, Luxembourg, Malta, Netherlands, Norway, Portugal, Slovakia, Spain, Sweden, Switzerland and the United Kingdom.

---

1) In preparation.

## 1 Scope

This European Standard specifies a test method for determination of the resistance to flame of cold applied joint sealants for use in joints in roads, air fields and other exposed concrete pavements.

## 2 Normative references

This European Standard incorporates by dated or undated reference, provisions from other publications. These normative references are cited at the appropriate places in the text, and the publications are listed hereafter. For dated references, subsequent amendments to or revisions of any of these publications apply to this European Standard only when incorporated in it by amendment or revision. For undated references the latest edition of the publication referred to applies (including amendments).

EN 26927:1990, *Building construction - Jointing products - Sealants - Vocabulary (ISO 6927:1981)*.

EN 28340:1990, *Building construction - Jointing products - Sealants - Determination of tensile properties at maintained extension (ISO 8340:1984)*.

## 3 Terms and definitions

For the purposes of this European Standard, the terms and definitions given in EN 26927:1990 apply.

## 4 Principle

The resistance to flame of cold applied joint sealants is determined by subjecting it to the flame for a specified time.

## 5 Apparatus and materials

**5.1** High temperature laboratory burner, rated to supply up to 3 000 W and capable of burning approximately 200 g of propane per hour at operating capacity.

**5.2** draught shield consisting of an open ended cylinder of light gauge metal with a diameter of  $(125 \pm 3)$  mm and a height of  $(300 \pm 5)$  mm.

**5.3** Steel specimen support, made from two 150 mm long rods and two 50 mm long rods, all of 3 mm nominal diameter, to form a support with a rectangular centre opening of 40 mm × 50 mm as shown in Figure 1.

**5.4** Temperature measuring device, capable of measuring of up to 300 °C with an accuracy of  $\pm 5$  °C.

## 6 Preparation of test specimens

One test specimen made and cured in accordance with EN 28340:1990 method B shall be used.

## 7 Procedure

- 7.1 Assemble the apparatus using a tripod as a support for the cylindrical draught shield (see Figure 1).
- 7.2 Centre the high temperature burner (5.1) under the draught shield (see 5.2) with the top in the same place as the bottom of the draught shield.
- 7.3 Centre the specimen support on the top of the draught shield (see 5.2) with the temperature measuring device (see 5.4) in a horizontal position laid on it with the sensor at the centre.
- 7.4 Regulate the high temperature laboratory burner (see 5.1) to produce a reading of constant temperature ( $260 \pm 10$ ) °C for ( $120 \pm 1$ ) s.
- 7.5 Substitute the specimen for the temperature measuring device by the test specimen so that the sealant itself, its 12,5 mm × 75 mm faces horizontal, is directly in the centre of the steel specimen support (see 5.3).
- 7.6 Leave in position for ( $120 \pm 1$ ) s and observe the sealant for signs of ignition, hardening, flow and separation.
- 7.7 At the end of the ( $120 \pm 1$ ) s remove the high temperature laboratory burner (see 5.1) and allow the specimen to cool to room temperature.
- 7.8 When cooled, examine the specimen for signs of flow, cracking, flaking, hardening ignition and any other effects caused by the flame.
- 7.9 record the effects produced by flame treatment.

Dimension in millimetres

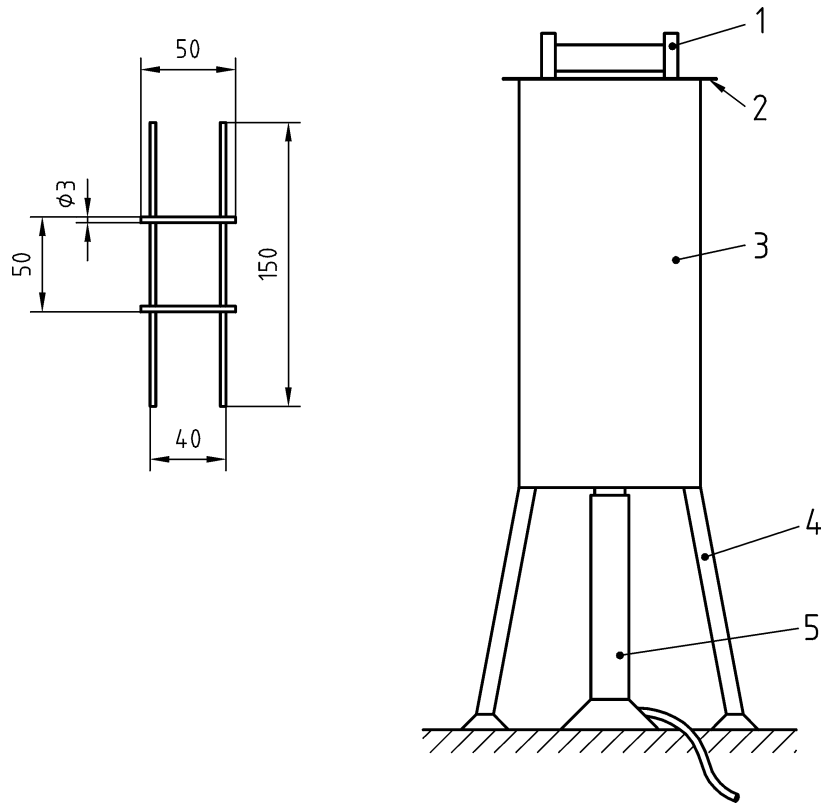

**Key**

- 1 Sealant specimen
- 2 Steel specimen support
- 3 Draught shield
- 4 Tripod
- 5 High temperature laboratory burner

**Figure 1 — Test device for flame resistance test**



## 8 Test report

The test report shall include the following information:

- a) reference to this European Standard;
- b) name and type of sealant;
- c) batch of sealant from which the test specimens were produced;
- d) type or types of support material;
- e) the primer used, if applicable;
- f) the method of conditioning used;
- g) time and temperature of test;
- h) description of any the effects produced by flame treatment;
- i) any deviations from the specified test conditions;
- j) date of test.

---

---

## BSI — British Standards Institution

BSI is the independent national body responsible for preparing British Standards. It presents the UK view on standards in Europe and at the international level. It is incorporated by Royal Charter.

### Revisions

British Standards are updated by amendment or revision. Users of British Standards should make sure that they possess the latest amendments or editions.

It is the constant aim of BSI to improve the quality of our products and services. We would be grateful if anyone finding an inaccuracy or ambiguity while using this British Standard would inform the Secretary of the technical committee responsible, the identity of which can be found on the inside front cover. Tel: +44 (0)20 8996 9000. Fax: +44 (0)20 8996 7400.

BSI offers members an individual updating service called PLUS which ensures that subscribers automatically receive the latest editions of standards.

### Buying standards

Orders for all BSI, international and foreign standards publications should be addressed to Customer Services. Tel: +44 (0)20 8996 9001. Fax: +44 (0)20 8996 7001. Email: [orders@bsi-global.com](mailto:orders@bsi-global.com). Standards are also available from the BSI website at <http://www.bsi-global.com>.

In response to orders for international standards, it is BSI policy to supply the BSI implementation of those that have been published as British Standards, unless otherwise requested.

### Information on standards

BSI provides a wide range of information on national, European and international standards through its Library and its Technical Help to Exporters Service. Various BSI electronic information services are also available which give details on all its products and services. Contact the Information Centre. Tel: +44 (0)20 8996 7111. Fax: +44 (0)20 8996 7048. Email: [info@bsi-global.com](mailto:info@bsi-global.com).

Subscribing members of BSI are kept up to date with standards developments and receive substantial discounts on the purchase price of standards. For details of these and other benefits contact Membership Administration. Tel: +44 (0)20 8996 7002. Fax: +44 (0)20 8996 7001. Email: [membership@bsi-global.com](mailto:membership@bsi-global.com).

Information regarding online access to British Standards via British Standards Online can be found at <http://www.bsi-global.com/bsonline>.

Further information about BSI is available on the BSI website at <http://www.bsi-global.com>.

### Copyright

Copyright subsists in all BSI publications. BSI also holds the copyright, in the UK, of the publications of the international standardization bodies. Except as permitted under the Copyright, Designs and Patents Act 1988 no extract may be reproduced, stored in a retrieval system or transmitted in any form or by any means – electronic, photocopying, recording or otherwise – without prior written permission from BSI.

This does not preclude the free use, in the course of implementing the standard, of necessary details such as symbols, and size, type or grade designations. If these details are to be used for any other purpose than implementation then the prior written permission of BSI must be obtained.

Details and advice can be obtained from the Copyright & Licensing Manager. Tel: +44 (0)20 8996 7070. Fax: +44 (0)20 8996 7553. Email: [copyright@bsi-global.com](mailto:copyright@bsi-global.com).