

BS EN 14127:2011



BSI Standards Publication

Non-destructive testing — Ultrasonic thickness measurement

bsi.

...making excellence a habit.™

National foreword

This British Standard is the UK implementation of EN 14127:2011. It supersedes BS EN 14127:2004 which is withdrawn.

The UK participation in its preparation was entrusted to Technical Committee WEE/46, Non-destructive testing.

A list of organizations represented on this committee can be obtained on request to its secretary.

This publication does not purport to include all the necessary provisions of a contract. Users are responsible for its correct application.

© BSI 2011

ISBN 978 0 580 71098 8

ICS 19.100

Compliance with a British Standard cannot confer immunity from legal obligations.

This British Standard was published under the authority of the Standards Policy and Strategy Committee on 31 March 2011.

Amendments issued since publication

Date	Text affected
------	---------------

EUROPEAN STANDARD

EN 14127

NORME EUROPÉENNE

EUROPÄISCHE NORM

February 2011

ICS 19.100

Supersedes EN 14127:2004

English Version

Non-destructive testing - Ultrasonic thickness measurementEssais non destructifs - Mesurage de l'épaisseur par
ultrasons

Zerstörungsfreie Prüfung - Dickenmessung mit Ultraschall

This European Standard was approved by CEN on 25 December 2010.

CEN members are bound to comply with the CEN/CENELEC Internal Regulations which stipulate the conditions for giving this European Standard the status of a national standard without any alteration. Up-to-date lists and bibliographical references concerning such national standards may be obtained on application to the CEN-CENELEC Management Centre or to any CEN member.

This European Standard exists in three official versions (English, French, German). A version in any other language made by translation under the responsibility of a CEN member into its own language and notified to the CEN-CENELEC Management Centre has the same status as the official versions.

CEN members are the national standards bodies of Austria, Belgium, Bulgaria, Croatia, Cyprus, Czech Republic, Denmark, Estonia, Finland, France, Germany, Greece, Hungary, Iceland, Ireland, Italy, Latvia, Lithuania, Luxembourg, Malta, Netherlands, Norway, Poland, Portugal, Romania, Slovakia, Slovenia, Spain, Sweden, Switzerland and United Kingdom.

EUROPEAN COMMITTEE FOR STANDARDIZATION
COMITÉ EUROPÉEN DE NORMALISATION
EUROPÄISCHES KOMITEE FÜR NORMUNG**Management Centre: Avenue Marnix 17, B-1000 Brussels**

Contents

	Page
Foreword.....	4
1 Scope	5
2 Normative references	5
3 Terms and definitions	5
4 Measurement modes	5
5 General requirements.....	7
5.1 Instruments	7
5.2 Probes.....	7
5.3 Couplant	7
5.4 Reference blocks	7
5.5 Test objects	7
5.6 Qualification of personnel	8
6 Application of the technique	8
6.1 Surface conditions and surface preparation	8
6.2 Technique	8
6.2.1 General.....	8
6.2.2 Measurement during manufacture.....	9
6.2.3 In-service measurement of residual wall thickness.....	9
6.3 Selection of probe.....	9
6.4 Selection of instrument.....	10
6.5 Materials different from the reference	10
6.6 Special measuring conditions.....	10
6.6.1 General.....	10
6.6.2 Measurements at temperatures below 0 °C	11
6.6.3 Measurements at elevated temperatures	11
6.6.4 Hazardous atmospheres	11
7 Instrument setting.....	11
7.1 General.....	11
7.2 Methods	12
7.2.1 General.....	12
7.2.2 Digital thickness instruments.....	12
7.2.3 A-scan Instruments	12
7.3 Check of settings	13
8 Influence on accuracy	14
8.1 Operational conditions.....	14
8.1.1 Surface conditions.....	14
8.1.2 Surface temperature.....	14
8.1.3 Metallic coating	15
8.1.4 Non-metallic coating	15
8.1.5 Geometry	16
8.2 Equipment	17
8.2.1 Resolution	17
8.2.2 Range	17
8.3 Evaluation of accuracy.....	18
8.3.1 General.....	18
8.3.2 Influencing parameters	18
8.3.3 Method of calculation	18

9	Influence of materials	18
9.1	General.....	18
9.2	Inhomogeneity	18
9.3	Anisotropy	18
9.4	Attenuation	18
9.5	Surface conditions	18
9.5.1	General.....	18
9.5.2	Contact surface.....	19
9.5.3	Reflecting surface.....	19
9.5.4	Corrosion and erosion	20
10	Test report	20
10.1	General.....	20
10.2	General information.....	20
10.3	Inspection data	21
Annex A	(informative) Corrosion in vessels and piping	22
A.1	General.....	22
A.2	Measurement of general corrosion.....	22
A.2.1	Instrument	22
A.2.2	Probes.....	22
A.2.3	Setting of the instrument	22
A.2.4	Measuring.....	23
A.3	Measurement of corrosion with pitting	23
A.3.1	Instrument	23
A.3.2	Probes.....	23
A.3.3	Setting of the instrument	23
A.3.4	Measuring.....	23
Annex B	(informative) Instrument settings	29
Annex C	(informative) Parameters influencing accuracy	31
C.1	Parameters influencing accuracy	31
C.2	Methods of calculation	33
Annex D	(informative) Measuring technique selection	36
Bibliography	40

Foreword

This document (EN 14127:2011) has been prepared by Technical Committee CEN/TC 138 “Non-destructive testing”, the secretariat of which is held by AFNOR.

This European Standard shall be given the status of a national standard, either by publication of an identical text or by endorsement, at the latest by August 2011, and conflicting national standards shall be withdrawn at the latest by August 2011.

Attention is drawn to the possibility that some of the elements of this document may be the subject of patent rights. CEN [and/or CENELEC] shall not be held responsible for identifying any or all such patent rights.

This document supersedes EN 14127:2004, which has been editorially revised, in order to take into account the new edition of EN 1330-4:2010.

According to the CEN/CENELEC Internal Regulations, the national standards organizations of the following countries are bound to implement this European Standard: Austria, Belgium, Bulgaria, Croatia, Cyprus, Czech Republic, Denmark, Estonia, Finland, France, Germany, Greece, Hungary, Iceland, Ireland, Italy, Latvia, Lithuania, Luxembourg, Malta, Netherlands, Norway, Poland, Portugal, Romania, Slovakia, Slovenia, Spain, Sweden, Switzerland and the United Kingdom.

1 Scope

This European Standard specifies the principles for ultrasonic thickness measurement of metallic and non-metallic materials by direct contact, based on measurement of time-of-flight of ultrasonic pulses only.

2 Normative references

The following referenced documents are indispensable for the application of this document. For dated references, only the edition cited applies. For undated references, the latest edition of the referenced document (including any amendments) applies.

EN 583-2, *Non-destructive testing — Ultrasonic examination — Part 2: Sensitivity and range setting*

EN 1330-4:2010, *Non-destructive testing — Terminology — Part 4: Terms used in ultrasonic testing*

3 Terms and definitions

For the purposes of this document, the terms and definitions given in EN 1330-4:2010 apply.

4 Measurement modes

The thickness of a part or structure is determined by accurately measuring the time required for a short ultrasonic pulse generated by a transducer to travel through the thickness of the material once, twice or several times.

The material thickness is calculated by multiplying the known sound velocity of the material with the transit time and dividing by the number of times the pulse transits the material wall.

This principle can be accomplished by applying one of the following modes, see Figure 1:

- a) Mode 1: Measure the transit time from an initial excitation pulse to a first returning echo, minus a zero correction to account for the thickness of the transducer wear surface and the couplant layer (single echo mode).
- b) Mode 2: Measure the transit time from the end of a delay line to the first backwall echo (single echo delay line mode).
- c) Mode 3: Measure the transit time between back-wall echoes (multiple echoes).
- d) Mode 4: Measure the transit time for a pulse travelling from the transmitter to a receiver in contact with the back-wall (through transmission mode).

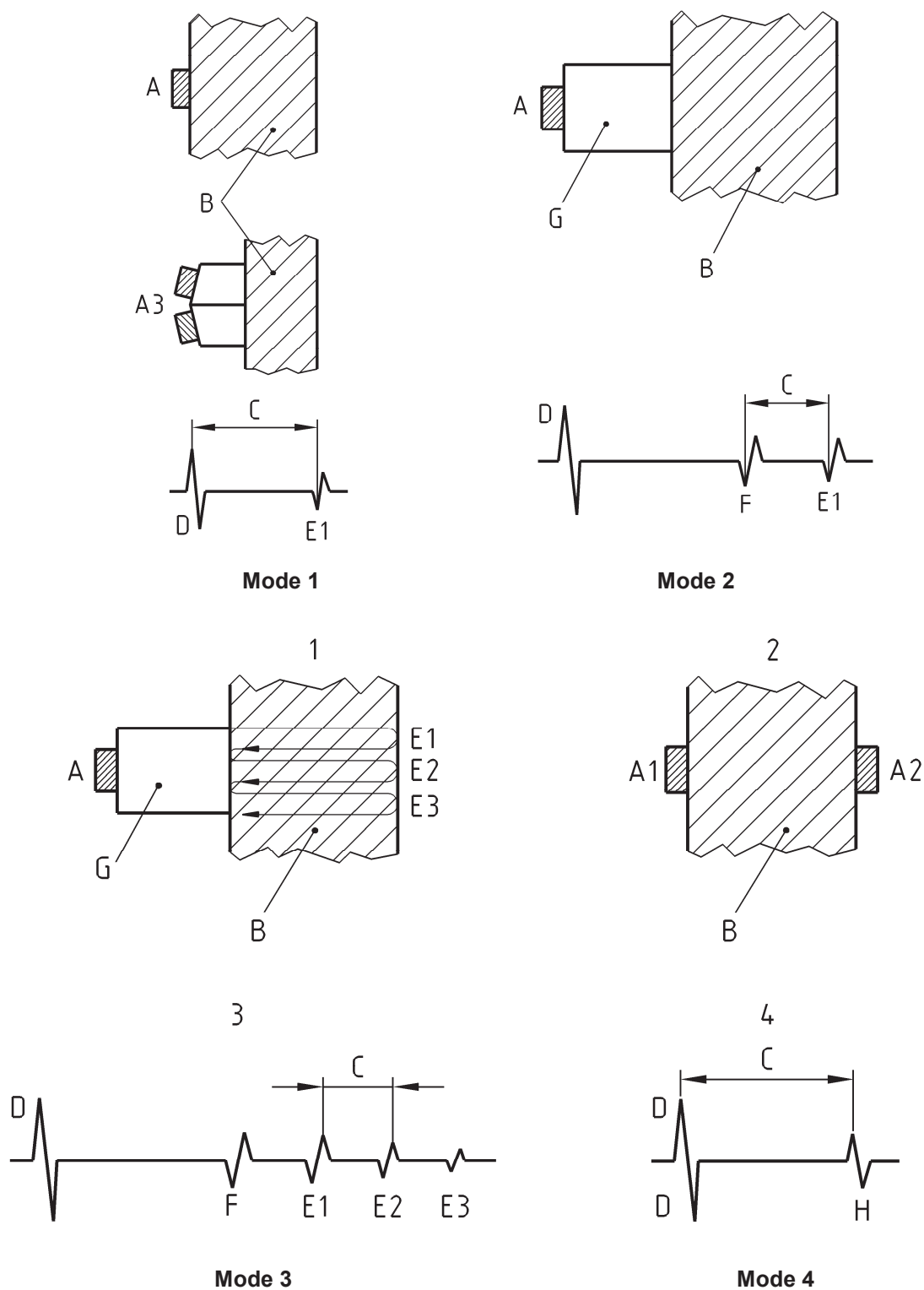

Key

- | | | | |
|----|------------------------|----------|-------------------------------|
| A | transmit/receive probe | D | transmission pulse indication |
| A1 | transmit probe | E1 to E3 | back-wall echoes |
| A2 | receive probe | F | interface echo |
| A3 | dual element probe | G | delay path |
| B | test object | H | received pulse |
| C | sound path travel time | | |

Figure 1 — Measurement modes

5 General requirements

5.1 Instruments

Thickness measurement can be achieved by using the following types of instruments:

- a) dedicated ultrasonic thickness measurement instruments with numerical display showing the measured value;
- b) dedicated ultrasonic thickness measurement instruments with numerical display showing the measured value and A-scan presentation (waveform display);
- c) instruments designed primarily for detection of discontinuities with A-scan presentation of signals. This type of instrument may also include numerical display of thickness values.

See 6.4.

5.2 Probes

The following types of probes are used, these are generally longitudinal wave probes:

- dual element probes;
- single transducer probes.

See 6.3.

5.3 Couplant

Acoustic contact between probe (probes) and material has to be provided, normally by application of a fluid or gel.

The couplant shall not have any adverse effect on the test object, the equipment or represent a health hazard to the operator.

For couplant to be used in special measuring conditions see 6.6.

The coupling medium should be chosen to suit the surface conditions and the irregularities of the surface to ensure adequate coupling.

5.4 Reference blocks

The measuring system shall be calibrated on one or more samples or reference blocks representative of the object to be measured, i.e. having comparable dimensions, material and structure. The thickness of the blocks or the steps should cover the range of thickness to be measured. Either the thickness or the sound velocity of the reference blocks shall be known.

5.5 Test objects

The object to be measured shall allow for ultrasonic wave propagation.

There shall be free access to each individual area to be measured.

The surface of the area to be measured shall be free of all dirt, grease, lint, scale, welding flux and spatter, oil or other extraneous matter that could interfere with the examination.

If the surface is coated, the coating shall have good adhesion to the material. Otherwise it shall be removed.

When measuring through coating its thickness and sound velocity need to be known unless mode 3 is used.

For further details, see Clause 8.

5.6 Qualification of personnel

An operator performing ultrasonic thickness measurement according to this document shall have a basic knowledge of the physics of ultrasonics, and a detailed understanding and training related to ultrasonic thickness measurements. In addition, the operator shall have knowledge of the product and material to be measured.

It is assumed that ultrasonic thickness testing is performed by qualified and capable personnel. In order to prove this qualification, it is recommended to certify the personnel in accordance with EN 473 or equivalent.

Note that for pressure equipment in categories III and IV according to Directive 97/23/EC, Annex I, 3.1.3: the personnel must be approved by a third-party organization recognized by a Member State.

6 Application of the technique

6.1 Surface conditions and surface preparation

Using the pulse-echo method means that the ultrasonic pulse has to pass the contact surface between test object and the probe at least twice: when entering the object and when leaving it.

Therefore a clean and even contact area with at least two times the probe's diameter is preferred. Poor contact will result in loss of energy, distortion of signal and sound path.

To enable sound propagation all loose parts and non adherent coatings shall be removed by brushing or grinding.

Attached layers, like colour coating, plating, enamels, may stay on the object, but only a few thickness meters are able to exclude these layers from being measured.

Very often thickness measurements have to be done on corroded surfaces, e.g. storage tanks and pipelines. To increase measuring accuracy the contact surface should be ground within an area at least two times the probe's diameter. This area should be clean from corrosion products.

6.2 Technique

6.2.1 General

The task of ultrasonic thickness measurements can be separated into two application areas:

- measurement during manufacture;
- in-service measurements of residual wall thickness.

Each area has its own special conditions which require special measuring techniques.

With a knowledge of the material, geometry and thickness to be measured and the required accuracy the most suitable measuring equipment and mode can be selected. Annex D gives further guidance:

- a) depending on the thickness and the material, frequencies from 100 kHz with through transmission on highly attenuative materials up to 50 MHz on thin metal sheets shall be used;
- b) if dual element probes are used then compensation for V-path error is required;
- c) on curved objects the diameter of the probe contact area shall be significantly smaller than the diameter of the test object;

- d) the accuracy of the thickness measurement depends on how accurate the time-of-flight can be measured, depending on the mode of time-measuring (zero crossing, flank-to-flank, peak-to-peak), depending on the mode chosen (with multiple echoes, mode 3, the accuracy is higher than with modes 1 and 2), depending on the frequencies which can be used (higher frequencies provide higher accuracy than lower frequencies because of the more accurate time measurement);
- e) ultrasonic thickness measurement is often required over an area of the component to be measured. Where this is the case consideration should be given to the spacing between each measurement. Such spacing should be even and the use of a grid is recommended. The grid size should be selected to give a balance between the confidence in the results and the work content involved.

Measuring the thickness ultrasonically means measuring the time-of-flight and then calculating the thickness assuming a constant sound velocity (see Clause 7). If the velocity is not constant within the path the ultrasonic pulse has travelled the accuracy of the measurement will be severely affected.

6.2.2 Measurement during manufacture

6.2.2.1 Modes 1, 2 and 3

Where the pulse echo mode is used, the flow charts in Figures D.1 and D.2 give guidance on the selection of the best method and equipment.

Thickness measurement on clean parallel surfaces may be carried out with simple numerical display thickness instruments.

On composite materials which generate echoes in addition to the back-wall echo, it is recommended that thickness instruments with A-scan displays (type 5.1 b) or 5.1 c)) are used to select the correct echo of the thickness measurement.

6.2.2.2 Mode 4

If the material is highly attenuative and large thicknesses have to be measured, no echo technique can be used, i.e. only through transmission (mode 4) is applicable.

Two probes on opposite sides of the test object have to be used. The instrument therefore shall allow for operation with separate transmitter and receiver (TR mode). In most cases the frequency shall be lower than 1 MHz. Special low frequency instruments from group c) in 5.1 with low frequency probes shall be used.

6.2.3 In-service measurement of residual wall thickness

During in-service inspection, measurements have to be taken on materials that are subject to corrosion or erosion. The surfaces may be rough and contain pitting or other defects (see Annex A) which are areas of low reflectivity.

For these applications the use of double transducer probes is recommended. The sensitivity shall be set manually to detect the bad reflecting areas.

Where it is necessary to take a lot of measurements, the readings shall be values with the information on the location of the measuring point. Special inspection programs are available to achieve this (data logging).

With in-service inspection the environmental conditions are very important. Equipment may be needed which can withstand high temperatures and harsh environments or has special electrical shielding.

The flow charts in Figures D.3 and D.4 give guidance on in-service thickness measurements.

6.3 Selection of probe

Having chosen a suitable measurement procedure according to 6.2, i.e. a general decision for a probe type (single or dual element) has been made, there are other parameters that need to be considered when matching the probe to the measuring conditions:

Wide band probes offer a shorter pulse than narrow band probes, thus giving a suited flank or peak to start and stop the time-of-flight measurement, giving a better resolution when measuring thin sheets or coatings.

Additionally a wide frequency band always gives a stable echo even when attenuating materials have to be measured.

Probe size and frequency shall be chosen to cover the measurement range by a narrow sound beam to get an echo from a well defined area.

For dual element probes the focal range should cover the expected thickness range.

When measuring small thicknesses a delay path should be used. The measurement should be done with the interface echo (delay path / test object) and the first back-wall echo from the test object (mode 2) or to make the measurement using mode 3. The material of the delay path shall be chosen to generate a suitable interface echo. Using the same material as the test object will not generate an interface echo. When the material of the delay path has a lower acoustic impedance than the material to be tested, e.g. plastics delay on metals, there will be a phase shift of the interface echo. This has to be corrected to get accurate results. Some thickness instruments do this correction automatically.

For small thicknesses it is also possible to use a double transducer probe with small focal distance.

When measuring on hot surfaces, the delay path shall act as a thermal barrier.

The material chosen for delay has to withstand the temperatures of the test object. The influence of the temperature on the acoustical properties of the delay path has to be known (drift of sound attenuation and velocity). Data sheets of the probe manufacturers show the range of temperatures a probe is suitable for and the time it can be used on those temperatures.

6.4 Selection of instrument

Selection of instruments of type 5.1 a), b) or c) is done as follows:

- instruments of type 5.1 c) can be used for modes 1 to 4, see Clause 4, and can satisfy the conditions given in 6.2.2 and 6.2.3;
- instruments of type 5.1 b) can be used for modes 1, 2 and 3 only; see Clause 4, and can satisfy the conditions given in 6.2.2.1 and 6.2.3;
- instruments of type 5.1 a) may be preset by the manufacturer to work only in one of the modes 1, 2 or 3 (see Clause 4).

The instruments shall be selected to satisfy the individual requirements given in 6.2.2.1 or 6.2.3.

See also Annex D.

6.5 Materials different from the reference

See Table B.1.

6.6 Special measuring conditions

6.6.1 General

There shall be strict observation of all legislative procedures governing the safe use of chemicals and electrical equipment.

Where there is a requirement for high accuracy measurements the calibration or reference blocks used should be at the same temperature as the item under test.

6.6.2 Measurements at temperatures below 0 °C

For measurements below 0 °C the couplant chosen shall retain its acoustic characteristics and have a freezing point below the test temperature.

Most probes are rated for use between - 20 °C and + 60 °C, at temperatures below - 20 °C specially designed probes may be required and contact time should be limited as recommended by the manufacturer.

6.6.3 Measurements at elevated temperatures

For measurements above 60 °C a high temperature probe is required and the couplant shall be designed for use at the test temperature.

It is also recommended that when using A-scan equipment it should have a "freeze" mode to allow the operator to assess the signal response. The probe contact time shall be limited to the minimum time necessary to achieve measurement as recommended by the manufacturer.

6.6.4 Hazardous atmospheres

In the measurement of thickness in hazardous atmospheres there shall be strict compliance with prevailing safety regulations and standards.

In explosive atmospheres the probe, cable and equipment combination shall be classified as intrinsically safe and relevant safety certification and or documentation shall be checked and completed prior to use.

In corrosive atmospheres the couplant shall not react adversely with the environment and shall retain its acoustic properties.

7 Instrument setting

7.1 General

All instrument setting shall be carried out with the same equipment as that which will be used for the measurements. Instrument setting shall be carried out in accordance with the manufacturer's instructions or other valid standards or procedures.

It should be noted that this clause covers only the setting of the instrument (in service), the verification of the equipment is not considered, but can be performed according to the design specification.

Ultrasonic instruments do not measure thickness; they measure time-of-flight. The thickness is calculated by the application of a factor which is the sound velocity of the material.

$$d = v \times t / n \quad (1)$$

where

d is the thickness;

v is the sound velocity;

t is the measured time;

n is the number of transits through the test object (see Figure 1).

7.2 Methods

7.2.1 General

The method for setting of the instrument shall suit the measuring mode and the equipment and probe in use. The setting shall be carried out under comparable operating conditions as those of the measurement instrument.

The tables in Annex B give guidance on the selection of methods for setting instruments.

Differences exist between calibrating a digital thickness instruments (types 5.1 a) and b)) and an A-scan instrument (type 5.1 c)).

7.2.2 Digital thickness instruments

See also 5.1 a) and 5.1 b).

Many digital thickness instruments can be used in measurement modes 1, 2 and 3. The setting of the instrument can be achieved in either of two ways:

- adjust the displayed reading such that it agrees with the measured known dimensions of the series of reference blocks;
- adjust or set the material velocity on the instrument to agree with the known velocity of the test object.

7.2.3 A-scan Instruments

See also 5.1, c).

Reference to EN 583-2 shall be made for information regarding the time base setting of an A-scan instrument.

When using mode 1 with an A-scan instrument the horizontal time base is set such that the transmission pulse indication and the first back-wall echo from the reference block are displayed at convenient positions on the screen to agree with a screen graticule or the digital display.

When using mode 2 with an A-scan instrument adjust the transmission pulse indication such that it is off the screen and the interface echo is at zero on the graticule. Then adjust the first back wall echo to be at the mark relating to the known thickness of the reference block.

When using mode 3 with an A-scan instrument, adjust the first back-wall echo to be at the mark relating to the known thickness of the reference block. Then adjust the n^{th} back-wall echo to be at the mark relating to the n times the known thickness of the reference block. When measuring the test object, the zero point of the graticule will correspond to the surface of the test object. The object thickness is equal to the position of the n^{th} back-wall echo divided by n . n is normally in the range 2 to 10. See Figure 2.

Mode 4 can only be used with an A-scan instrument. The instrument shall be set up to operate in through transmission mode according to the manufacturer's manual. A transmission pulse indication should be available to represent the zero time pulse, set this to align with the zero on the graticule and the received pulse is set to align with a known thickness on the graticule.

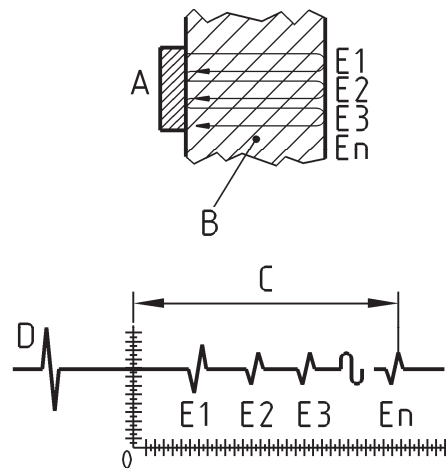

Key

- A transmit/receive probe
- B test object
- C sound path travel time
- D transmission pulse indication
- E1 to En backwall echoes

Figure 2 — Instrument setting for mode 3

7.3 Check of settings

Checks of the settings of a thickness measuring system shall be carried out with a reference test piece:

- a) on completion of all measurement work;
- b) at regular intervals during the work session;
- c) if probes or cables are changed;
- d) if material types are changed;
- e) if the material or equipment temperature changes significantly;
- f) if major operating controls are adjusted or considered altered;
- g) at other intervals as directed by specific procedural instructions.

8 Influence on accuracy

8.1 Operational conditions

8.1.1 Surface conditions

8.1.1.1 Cleanliness

The cleanliness of the piece affects its thickness measurement. Inadequate surface preparation may lead to inconsistent results.

Adhering dirt and scale shall be removed by brushing before measurement.

8.1.1.2 Roughness

Roughness interferes with the estimate of thickness (overvaluation) and modifies the coefficients of reflection and transmission at the interface.

In circumstances where there is significant roughness the sound path is increased and the contact surface is reduced. The measurement uncertainty increases with decreasing thickness.

If the surface opposite the input surface (back-wall surface) is rough the acoustic signal can be deformed, this can result in measurement error.

8.1.1.3 Surface profile

Scanning on an irregular surface with a contact probe necessitates the use of a thick couplant layer. This may create beam distortion.

When using modes 1, 2 or 4 the couplant layer transit time may be included in the reading, which will result in an additive error equivalent to three to four times the actual couplant depth. In this case it is not possible to determine the minimum remaining wall thickness.

The coupling medium should be chosen to suit the surface conditions and the irregularities of the surface to ensure adequate coupling.

8.1.2 Surface temperature

Temperature modifies the sound velocity (in both the material and in any delay path and face of the probe) and also the overall acoustic attenuation.

As for all measurements, if maximum accuracy is required then the temperature variation and effect upon the following additional items has to be considered:

- references: standards, gauges, test-blocks;
- apparatus: equipment, probes, etc.;
- process and methods: couplant, object under test.

Sound velocity decreases with increase in temperature in most metals and plastics, whereas it can be seen to increase in glass and ceramics.

The influence of temperature on the velocity of sound in metals is normally insignificant. The longitudinal (compressional) wave velocity in most steels decreases by approximately $0,8 \text{ ms}^{-1} \text{ } ^\circ\text{C}^{-1}$.

The influence of temperature on plastics is significant. For acrylic, which is normally used for probe delays, the coefficient is $-2,5 \text{ ms}^{-1} \text{ } ^\circ\text{C}^{-1}$. Compensation for this shall be applied.

8.1.3 Metallic coating

Apparent increase of the material thickness (or even apparent decrease in the case of heat treated material) can be seen when cladding (constitution, composition, thickness, cladding process, number of layers, etc.) is not taken into account.

The measurement accuracy required shall dictate whether the plating should be considered.

For example, with the instrument calibrated for steel:

- Steel 1 mm at $v = 5\,920\text{ ms}^{-1}$;
- Zinc 20 μm at $v = 4\,100\text{ ms}^{-1}$;
- Actual thickness 1 mm + 20 $\mu\text{m} = 1,02\text{ mm}$;

$$\frac{(1 \times 10^{-3})}{5\,920} + \frac{(20 \times 10^{-6})}{4\,100} = 1,738^{-7}\text{ s} \quad (2)$$

$$1,738^{-7} \times 5\,920 = 1,029\text{ mm} \quad (3)$$

- Measured thickness 1,029 mm;
- Deviation 0,009 mm.

Cladding thickness can be measured. Measurement accuracy depends on the same parameters as the measurement of the base material.

8.1.4 Non-metallic coating

When measuring through coatings, errors will occur as a result of the differing sound velocities of the coating and the test object.

For example, with the instrument calibrated for steel:

- Steel 1 mm at $v = 5\,920\text{ ms}^{-1}$;
- Paint 100 μm at $v = 2\,100\text{ ms}^{-1}$ (this is a generic value and not indicative of a type);
- Actual thickness 1 mm + 100 $\mu\text{m} = 1,1\text{ mm}$;

$$\frac{(1 \times 10^{-3})}{5\,920} + \frac{(100 \times 10^{-6})}{2\,100} = 2,165^{-7}\text{ s} \quad (4)$$

$$2,165^{-7} \times 5\,920 = 1,282\text{ mm} \quad (5)$$

- Measured thickness 1,282 mm;
- Deviation 0,182 mm.

It can also be difficult to obtain the desired measurement if the coating material is:

- similar in acoustic properties to the test piece material;
- of a significant thickness compared to that of the test piece.

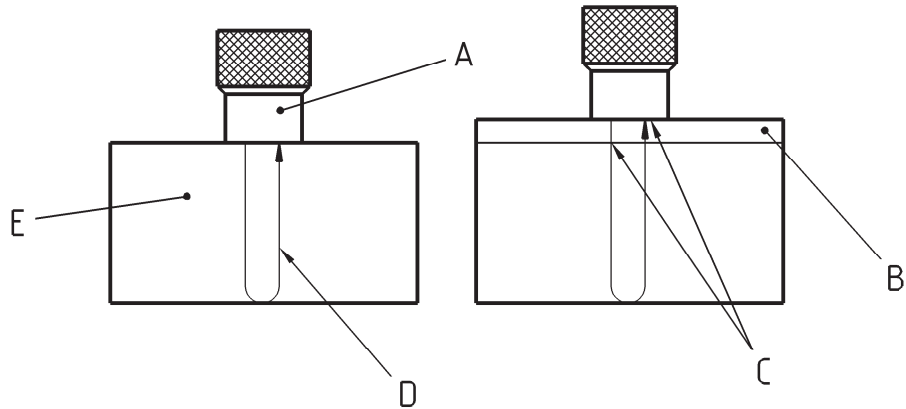

Key

- A probe
- B coating or plating
- C increased sound path through coating
- D sound path travel time
- E metal

Figure 3 — Increased sound path through coating

8.1.5 Geometry

8.1.5.1 Parallelism

The opposite walls of the test object (piece) should be parallel within $\pm 10^\circ$ otherwise measurement can be difficult or erroneous. This is due to deformation or lack of back-wall echoes due to “spatial integration”.

8.1.5.2 Curved surfaces

In this case the small contact surface area between the probe and the test piece can reduce the effectiveness of the couplant and in turn the signal quality. The probe shall be aligned to the centre of curvature of the test object. These factors will affect measurement performance by giving poor acoustic transmission and repeatability.

8.1.5.3 Concave and convex scanning surfaces

The probe face shall always allow adequate coupling. Small radii require a small probe diameter.

8.1.5.4 Range of thickness

Accurate measurement depends on material homogeneity throughout its thickness. Local or general changes of composition will result in changes of velocity compared to that of the material of reference blocks and therefore subsequent measurement errors.

8.2 Equipment

8.2.1 Resolution

True equipment resolution is the smallest increment of the quantity being measured that can be recognised by the system. E.g. digital thickness instruments may display an apparent resolution of 0,001 mm but only be capable of measuring with a resolution of 0,01 mm. An A-scan instrument (type 5.1 c)) has no stated or assumed thickness resolution, it depends on a number of factors, e.g. digitising speed, screen resolution (pixel number in the x and y axes) and time base setting.

Equipment resolution is influenced by the choice of probe type and frequency.

Higher probe frequencies provide greater thickness resolution than lower frequencies do. This is basically because the higher frequency pulses offer a sharper and more definite timing edge. This is particularly noticeable on A-scan instruments.

8.2.2 Range

The range of the equipment is that range of thickness that the system can practically measure. The number of digits on the display of a digital instrument only infers a range of numbers that can be displayed.

Instruments will have a minimum thickness that they can measure. This is generally independent of probe frequency and application. The maximum thickness that can be measured is usually governed by probe frequency and/or application (material conditions, etc.).

The probe will dictate a measurement range independent of the instrument. Generally, the minimum range of a probe is controlled by its frequency and the velocity of the material being tested. A probe shall be chosen such that its minimum measurable thickness is below the minimum thickness to be measured.

As a guide it can be assumed that a probe cannot measure less than one whole wavelength at the velocity in question.

$$\lambda = v/f \tag{6}$$

where

λ is the wavelength;

f is the probe frequency;

v is the sound velocity.

Probe frequency also dictates the maximum thickness that can be measured. A high frequency probe will have less penetrating power than a lower frequency one.

Consideration should be given to the type of material in question as this also has an affect on measuring range.

The selection of probe frequency is controlled by the range of material thickness to be measured and also by the type of material.

The measuring system shall be selected such that its measuring range properly covers the thickness of interest. In the case of an A-scan instrument (type 5.1 c)) the range setting shall be such that it suits the desired resolution at that range without switching ranges.

It is recommended that instrument settings are checked at both ends of the thickness range to be measured.

8.3 Evaluation of accuracy

8.3.1 General

The evaluation is dependent on several parameters and the method of calculation.

8.3.2 Influencing parameters

The most important parameters are shown in C.1.

8.3.3 Method of calculation

Two basic methods are shown in C.2.

9 Influence of materials

9.1 General

The material of the object to be measured may influence the selection of technique to be applied for ultrasonic thickness measurement.

Forged or rolled metals normally have a low attenuation and a constant and well-defined sound velocity. These materials are easily measured using standard procedures described in Clause 4.

9.2 Inhomogeneity

Material composition including alloying elements and impurities, and its manufacturing process will affect grain structure and orientation and therefore homogeneity.

This can cause localised variation of velocity and attenuation in the material, resulting in erroneous measurements or in extreme cases the loss of readings.

9.3 Anisotropy

In anisotropic materials velocity is not necessarily the same in different planes and the structure may cause variations in beam directions. This will result in erroneous readings. Materials, which are rolled or extruded, particularly austenitic steel, copper and its alloys, lead and all fibre-reinforced plastics are examples of this.

To minimise the risk of error, setting of the instrument shall be carried out in the same plane as the measurement.

9.4 Attenuation

Acoustic attenuation is caused by energy loss through absorption (e.g. rubber) and by scattering (e.g. coarse grains). This effect can cause a reduction of signal amplitude or a signal distortion.

Castings generally exhibit attenuation through absorption and scattering resulting in lack of or erroneous readings.

High attenuation through absorption alone may be found in plastics.

9.5 Surface conditions

9.5.1 General

Poor attention to surface conditions will result in either inability to obtain measurements or erroneous measurements.

9.5.2 Contact surface

If the surface is coated measurement may only be achieved through the coating, provided it has good adhesion to the material. When measurements are made through coating, multiple echo technique shall be used, mode 3 (see Clause 4).

If only a single echo can be achieved due to bad reflection or high attenuation, the coating thickness equivalent shall be known and be subtracted from the single echo reading, see 8.1.3 and 8.1.4.

Where neither of these conditions can be met, the coating shall be removed, provided this is allowed.

Surface roughness for example caused by wear or corrosion highly influences the coupling conditions and the measurement accuracy. Extreme surface roughness may preclude measurement modes 2 and 3 (Clause 4) leaving single echo technique, mode 1, as the only alternative.

The resulting measurement values may not be considered more accurate than the surface condition allows. This is illustrated in Figure 4 showing a probe bridging a surface cavity. A measurement recorded in this position will include the equivalent of the couplant layer thickness.

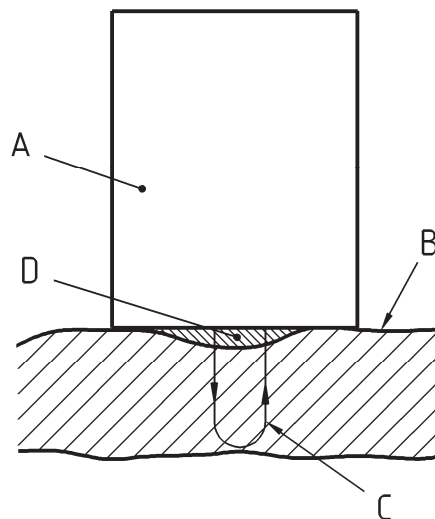

Key

- A probe
- B test object
- C sound path
- D couplant

Figure 4 — Sound path through couplant layer

9.5.3 Reflecting surface

Ultrasonic thickness measurements are frequently related to service-induced material loss by corrosion or erosion. These mechanisms produce different types of reflecting surfaces. When performing ultrasonic thickness measurements with the purpose of detecting material loss and/or measuring remaining wall thickness, it is necessary to have a knowledge of the type(s) of material loss to be expected, and to apply a procedure adapted to this specific type of wear, corrosion or erosion.

9.5.4 Corrosion and erosion

In industries such as oil/gas, power generation, energy distribution, storage and transport of products, the corrosion mechanisms are frequently linked to vessels and pipes made of ferrous materials such as rolled steel plates, seamless pipe and welded assemblies.

The following types of corrosion in steel vessels and piping components are to be considered when selecting the ultrasonic technique to be applied:

- uniform corrosion;
- pitting;
- deposit attack;
- crevice corrosion;
- galvanic corrosion;
- flow induced corrosion;
- weld zone corrosion;
- combinations of two or more of the above types of corrosion.

The illustrations in Annex A show important shapes and distributions of ultrasonic reflectors to be considered. Annex A also proposes technical data to be applied for detection and measuring.

10 Test report

10.1 General

Taking into account any specific requirements agreed at the time of enquiry and order the following information shall be recorded:

10.2 General information

- a) Operator's name;
- b) operator's qualification details;
- c) operator's company details;
- d) dates of first and last measurement in this report;
- e) location/site details;
- f) equipment type and serial number;
- g) probe type description (including element size/frequency) and serial number;
- h) reference block details, if applicable;
- i) couplant type;
- j) equipment measuring method/mode;

- k) material type;
- l) instrument setting details, i.e. method;
- m) general description of plant/structure/parts under inspection including definition of surface conditions, e.g. coated/insulated/rough/smooth/shot-blasted;
- n) details of company/agency requiring and purpose of survey;
- o) reference to applied standard or specifications;
- p) operator's signature.

10.3 Inspection data

- a) Measurement pattern descriptor;
- b) measurement point location descriptor/identifier;
- c) original thickness, if applicable;
- d) allowable tolerances (where known);
- e) measurement results (table and/or map);
- f) diminution as percent or actual, if applicable;
- g) supporting drawings showing locations of discontinuities;
- h) visual inspection/condition comments;
- i) supporting drawings/sketches showing measurement locations.

Annex A (informative)

Corrosion in vessels and piping

A.1 General

Corrosion in components such as vessels and piping can be caused by different mechanisms. Table A.1 gives some guidance regarding the types of ultrasonic reflectors, which may occur with the different corrosion mechanisms and some guidance regarding the ultrasonic techniques recommended for measurement of the remaining material thickness.

A.2 Measurement of general corrosion

A.2.1 Instrument

For general corrosion, digital display instruments may be used. If the instrument does not give reliable readings due to difficult surface conditions, inclusions in the material or heavy coating, an A-scan instrument should be used.

Where the measuring surface is coated and it is required to eliminate the coating thickness from the results, a suitable instrument that uses mode 3 should be used.

Where it is required to find the thinnest point within a given area, a scanning should be performed. For this purpose an A-scan instrument should be used.

Where many readings are to be recorded, an instrument with data logging facility should be considered.

A.2.2 Probes

Probe selection depends on equipment type, material thickness, surface condition and coating condition.

For digital display instruments the probes as specified by the manufacturer should be used. For A-scan instruments the following guidelines can be applied:

- the probe frequency should be selected such that it produces at least 1,5 times the wavelength in the test object (see 8.2.2);
- generally, single transducer probes should be used for thicknesses of 10 mm and above. The multiple echo technique (mode 3) should only be used with single transducer probes;
- where thickness is below 10 mm, double transducer probes may be applied;
- if the thickness is expected to be below 5 mm, dual element probes with special focal range should be used;
- when the object is curved, consideration should be given to the selection of probe diameter;
- on a coated object a single transducer probe should be used with mode 3 to allow compensation for the coating thickness.

A.2.3 Setting of the instrument

Setting of the instrument is done on a step-wedge with a thickness range covering the expected range of the object. Material and temperature shall be equivalent to the object.

A.2.4 Measuring

Where several back-wall echoes may be read (only single transducer technique), the most accurate results are achieved by reading the n^{th} echo and dividing the reading with n . Where this technique is used on a coated surface, the distance from echo no. 1 to echo no. n is read and divided by $n-1$. Hereby the coating thickness is not included in the result.

Where only one back-wall echo is used, the reading should be taken in the same position of the echo as the reading during setting of the instrument. If the surface is coated, the coating thickness multiplied with the sound velocity ratio metal/coating is included in the reading and should be subtracted before recording the result.

Where high reproducibility is essential, the exact position of the measuring point is to be documented or assured in another way. Where it is essential to detect the thinnest point within a given area, scanning should be performed. This will normally require an A-scan instrument (type 5.1 b) or type 5.1 c)).

Use of digital display instruments should strictly follow the manufacturer's instructions.

Unexpected measurements may be due to internal discontinuities. These should be verified by supplementary investigations, e.g. by using angle-beam probes.

A.3 Measurement of corrosion with pitting

A.3.1 Instrument

For thickness measurement where pitting may be expected, an A-scan instrument should be used (type 5.1 b) or type 5.1 c)).

A.3.2 Probes

For detection of pitting, a dual element probe is the most suitable. The selected probe should have a focal distance corresponding to the expected distance to the pitting.

A.3.3 Setting of the instrument

The setting of the instrument is done on a step-wedge with a thickness range covering the expected range of the object. Material and temperature shall be equivalent to the object. Where small diameter pitting is expected, detection sensitivity is to be verified on a calibration block with small diameter flat-bottom holes in the same distance range as the expected pitting.

A.3.4 Measuring

When searching for pitting, only the first back-wall echo should be used. Echoes from pitting may occur together with the back-wall echo.

Where reflector type cannot be identified as either corrosion or inclusion, supplementary investigation should be carried out using angle probes. 45° angle probes are specially suited for differentiating between inclusions and pitting.

Table A.1 — Corrosion in steel – Recommended ultrasonic techniques

No.	Description	Typical corrosion origin and mechanism	Illustration	Recommended ultrasonic technique
1	Uniform corrosion	Occurs in corrosive environments such as: <ul style="list-style-type: none"> - water saturated with oxygen; - sour solutions; - condensed water from wet gas. 	 <p style="text-align: center;">Development in uniform corrosion</p>	A.2
2	Pitting	Corroded areas have clear limits while the adjacent areas are typically not attacked. Pitting can take different shapes, depending on structure and texture of the material, and on surface condition.	 <p style="text-align: center;"> Type A: Flat pitting Type C: Semi-circular pits Type B: Undermining pitting Type D: Surface breaking spherical </p>	A.3

Table A.1 — Corrosion in steel – Recommended ultrasonic techniques (continued)

No.	Description	Typical corrosion origin and mechanism	Illustration	Recommended ultrasonic technique
2a	Pitting	Distribution patterns		See Note
3	Deposit corrosion, Crevice corrosion	Occurs under deposits and in narrow water-filled crevices		See Note

Table A.1 — Corrosion in steel – Recommended ultrasonic techniques (continued)

No.	Description	Typical corrosion origin and mechanism	Illustration	Recommended ultrasonic technique
4	Galvanic corrosion	Dissimilar metals		See Note
5	Flow-induced corrosion			See Note

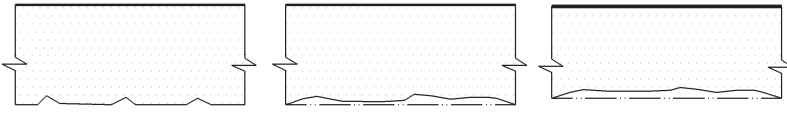
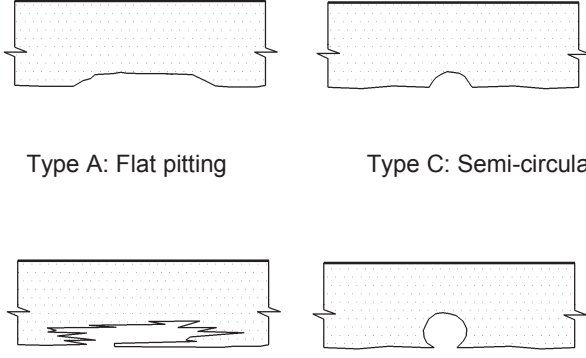
Table A.1— Corrosion in steel – Recommended ultrasonic techniques (continued)

No.	Description	Typical corrosion origin and mechanism	Illustration	Recommended ultrasonic technique
6	Turbulence corrosion			See Note
7	Mesa-type corrosion			See Note
8	Cavitation corrosion			See Note

Table A.1 — Corrosion in steel – Recommended ultrasonic techniques *(concluded)*

No.	Description	Typical corrosion origin and mechanism	Illustration	Recommended ultrasonic technique
9	Weld zone corrosion			See Note
<p>NOTE These corrosion forms are shown to illustrate the possibilities and difficulties that can be encountered when achieving to detect and quantify corrosion. The illustrations are for information only. A specific recommendation regarding the technique to be applied for each case cannot be given, as it would depend on the access conditions, material thicknesses and other parameters.</p>				

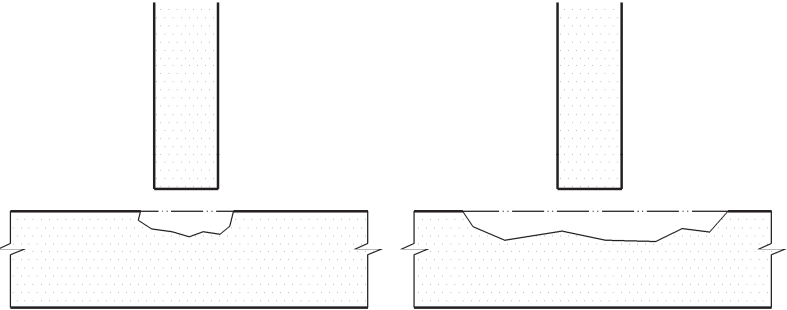
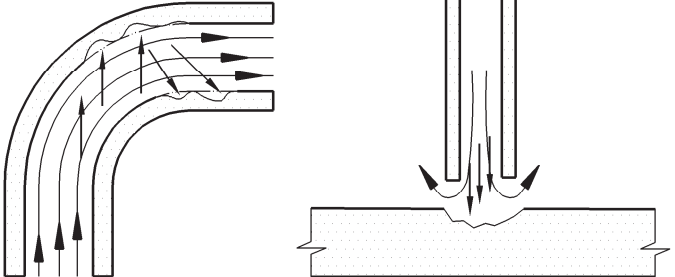
Annex B (informative)

Instrument settings

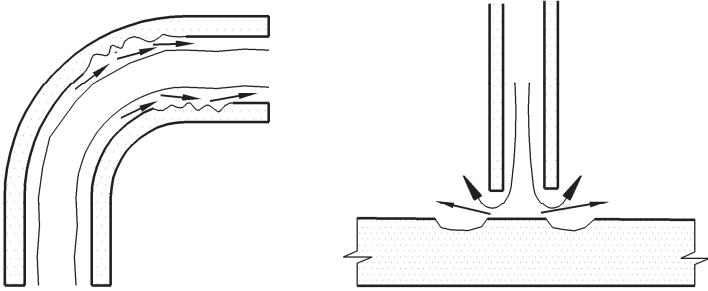
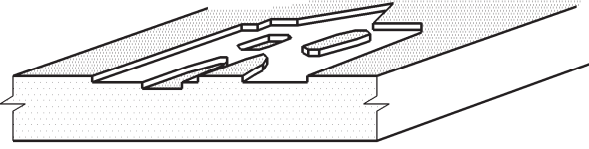
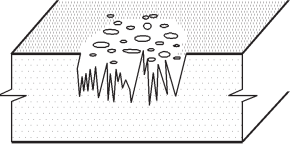
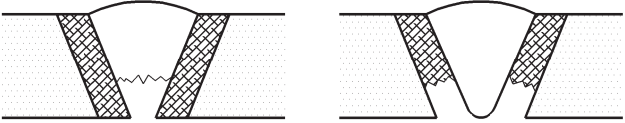
Table B.1 — Instrument setting on a reference block with multiple steps

SELECT REFERENCE BLOCK ...	OF SAME MATERIAL AND SAME SURFACE CONDITION	OF SAME MATERIAL AND OTHER SURFACE CONDITION	OF DIFFERENT MATERIAL AND SAME SURFACE CONDITION	OF DIFFERENT MATERIAL AND OTHER SURFACE CONDITION
CALIBRATE THE EQUIPMENT	Calibrate on a thickness above and below the thickness range to be measured.	Calibrate on a thickness above and below the thickness range to be measured.	Calibrate on a thickness above and below the thickness range to be measured.	Calibrate on a thickness above and below the thickness range to be measured.
VERIFY LINEARITY AT INTERMEDIATE STEPS ...	if more than 2 steps available	if more than 2 steps available	if more than 2 steps available	If more than 2 steps available
CORRECT THE SETTING	Not necessary	Check and correct zero setting on the test object	Re-calibrate on the test object if possible or use known velocity to correct the reading.	Re-calibrate on the test object if possible or check and correct zero setting on the test object and use known velocity value.
UNCERTAINTY OF MEASUREMENT RELATED TO SETTING OF THE INSTRUMENT DEPENDS ON ...	Accuracy of reference block thicknesses and, if only 2 steps used, uncertainty of linearity	Accuracy of reference block thicknesses and the surface condition of the test object and, if only 2 steps used, uncertainty of linearity	Accuracy of reference block thicknesses and accuracy of thicknesses of the test object or validity of known value of velocity and, if only 2 steps used, uncertainty of linearity	Accuracy of reference block thicknesses and accuracy of thicknesses of the test object and the surface condition of the test object or validity of known value of velocity and, if only 2 steps used uncertainty of linearity

Table B.2 — Instrument setting on a reference block with one thickness or without a reference block

REFERENCE BLOCK	OF SAME MATERIAL AND SAME SURFACE CONDITION	OF SAME MATERIAL AND OTHER SURFACE CONDITION	NO REFERENCE BLOCK OF SAME MATERIAL AVAILABLE
CALIBRATE THE EQUIPMENT	Set the velocity and zero to agree with the known value and thickness	Set the velocity and zero to agree with the known value and thickness	Set the velocity to a known value for the test object and Set zero by using a known value or by using mode 3 or by using automatic probe recognition
VERIFY LINEARITY AT INTERMEDIATE STEPS	Not possible	Not possible	Not possible
CORRECT THE SETTING	Not necessary	Check and correct zero setting on test object	Not possible
UNCERTAINTY OF MEASUREMENT RELATED TO SETTING OF INSTRUMENT DEPENDS ON	Accuracy of reference block thickness and uncertainty of linearity	Accuracy of reference block thickness and uncertainty of linearity and surface condition of the test object	The validity of the known values

Annex C (informative)

Parameters influencing accuracy

C.1 Parameters influencing accuracy

The following Table C.1 lists the parameters influencing accuracy:

Table C.1 — Table of parameters influencing accuracy

Item		Parameter	Result	Possible improvements
Test object	Material	Composition	Attenuation, absorption, scattering and local variation of velocity	Setting of instrument on the same material as test object
		Structure		
		Anisotropy		
	Surface condition	Cleanliness	Local variations of surface conditions lead to variations of couplant thickness	Cleaning
		Roughness		Grind surface as required
		Surface profile		Using of small diameter probe
	Coating	Coating	Coating velocity different from base material velocity resulting in inaccuracy	Removing coating or using mode 3
		Paint		
		Surface treatment		
	Geometry	Non-parallelism	Back-wall echo can disappear or can be distorted	Parallelism should be within the probes beam divergence angle ($\pm 1,22 \arcsin \lambda/d$)
		Curvature	Loss of coupling efficiency	Use a smaller diameter probe
		Range	Distortion of back-wall echo caused by attenuation	Using mode 1 and a lower probe frequency using mode 4

(continued)

Table C.1 — Table of parameters influencing accuracy (concluded)

Reference	Method	Uncertainty of calibration method	Inaccurate readings	Using block representative of part, steps thinner and thicker than expected thickness, choice of calibration method see Annex B
	Reference block	Thickness and velocity uncertainty	Accuracy cannot be better than block uncertainties	Accurate measurement of block thickness and sound velocity
Measuring	Equipment	Resolution	Accuracy cannot be better than system resolution	Using higher accuracy instrument, higher probe frequency and broadband probes
		Cable length	Excessive cable length distorts the signals	Using shorter cable and calibrate with the same cable
		Drift of instrument	Inaccurate readings	Warming-up the unit and wait for stable reading or use stable equipment
		Time of flight	Accuracy cannot be better than time of flight measurement accuracy	Using higher accuracy instrument
		Linearity	Inaccurate readings	Ensuring linearity of system
		Trigger point	Inaccurate readings	Selecting best trigger point
	Operation	V-path	Wrong reading because thickness differs from ultrasonic path	Using a thickness gage with V-path correction or taking into account the roof angle and separation Using a single element probe
		Phase shift	Erroneous reading	Taking the phase shift into account
Repeatability	Use of unit	Method	Improper operation	Providing correct procedure or instructions. Conducting repeatability tests
		Coupling	Bad coupling introduces dispersion in the readings.	Selecting couplant to suit the surface conditions Using mode 3 if possible
		User training	Error on reading	Operator training
Miscellaneous	Temperature	Variation of sound velocity	Error on reading	Calibrating at the same temperature as test object or correcting calibration for change of sound velocity

C.2 Methods of calculation

The following two methods illustrate ways to calculate inaccuracy of a reading:

a) Method C.2.1

Method C.2.1 calculates the inaccuracy of a measurement by adding the inaccuracies of all the influencing parameters.

b) Method C.2.2

Method C.2.2 is a method for calculating the inaccuracy, I_g , of a measurement result, MR , in accordance with ISO 14253-2 where the measurement result is equal to the reading, R , \pm the inaccuracy, I_g .

$$MR = R \pm I_g$$

where

$$I_g = K \sqrt{\sum_i \sigma_i^2}$$

K shall be chosen for a level of confidence, e.g.:

- 1) $K = 1$ for 68 % level of confidence;
- 2) $K = 2$ for 95 % level of confidence;
- 3) $K = 3$ for 99,8% level of confidence;

σ_i is the uncertainty for each parameter obtained:

- 4) either by statistical approach;
- 5) or by other methods, e.g. standards, specifications, analysis;

i is the different parameters which have been considered independent (for instance; surface condition, linearity, repeatability).

Statistical distribution:

- uniform or rectangular law: $\sigma_i = 0,6 a$;
- Gauss law: $\sigma_i = 0,5 a$,

where

a is the accuracy of the result.

Table C.2 — Illustrates the application of methods C.2.1 and C.2.2 where the test object is a steel plate 10 mm thick, surface roughness $R_a = 6,3 \mu\text{m}$

Parameter	Group	Factors	Measuring conditions	Estimated inaccuracy mm	
				Method C.2.1	Method C.2.2
Test object	Material	Composition	Ferritic steel	0	0
		Structure	Fine grained		
		Anisotropy			
	Surface condition	Cleanliness			
		Roughness	Surface $R_a = 6,3 \mu\text{m}$	0,006 3	0,003 2
		Surface profile	Flat		
	Coating	Coating	Not coated	0	0
		Paint	Not painted		
		Surface treatment	Un-treated		
	Geometry	Non-parallelism	Parallel faces	0	0
		Curve radius	No curvature		
		Range	Negligible attenuation		
Reference	Calibration Method	Uncertainty of calibration method	Reference block Same material / 5 step calibration	0	0
	Reference block	Thickness and velocity uncertainty	Thickness uncertainty: 0,01 mm Velocity uncertainty: $\pm 30 \text{ m/s}$	0,05	0,025

Table C.2 — Illustrates the application of methods C.2.1 and C.2.2 where the test object is a steel plate 10 mm thick, surface roughness $R_a = 6,3 \mu\text{m}$ (concluded)

Measuring	Equipment	Resolution	Digital instrument resolution: 0,01mm	0,01	0,006
		Cable length	Fixed length	0	0
		Drift of instrument	Stable instrument	0	0
		Time of flight	Accuracy of time measurement : 10 ns	0,03	0,018
		Linearity	1 % of the maximum range (manufacturer's data)	0,1	0,05
Measuring	Operation	Trigger point	Constant amplitude	0	0
		V-path	Single element probe	0	0
		Phase shift	No phase shift	0	0
Repeatability	Operation	Coupling	Coupling error included in method		
		User training	Qualified operator	0,1	0,05
Miscellaneous	Temperature	Variation of sound velocity	Measurement at room temperature, negligible variation	0	0
			Global error	0,306	0,135

Annex D (informative)

Measuring technique selection

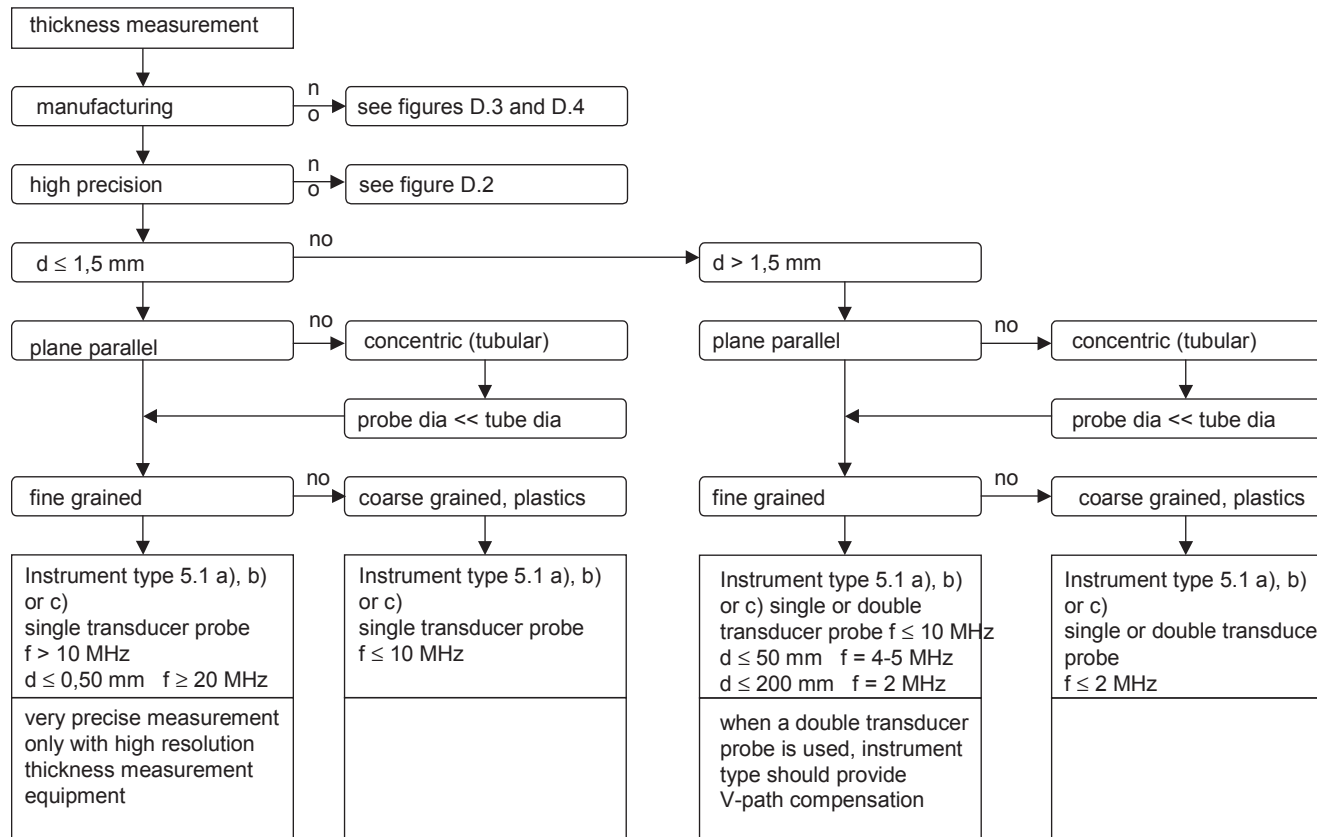

Figure D.1 — Flow chart for manufacturing inspection

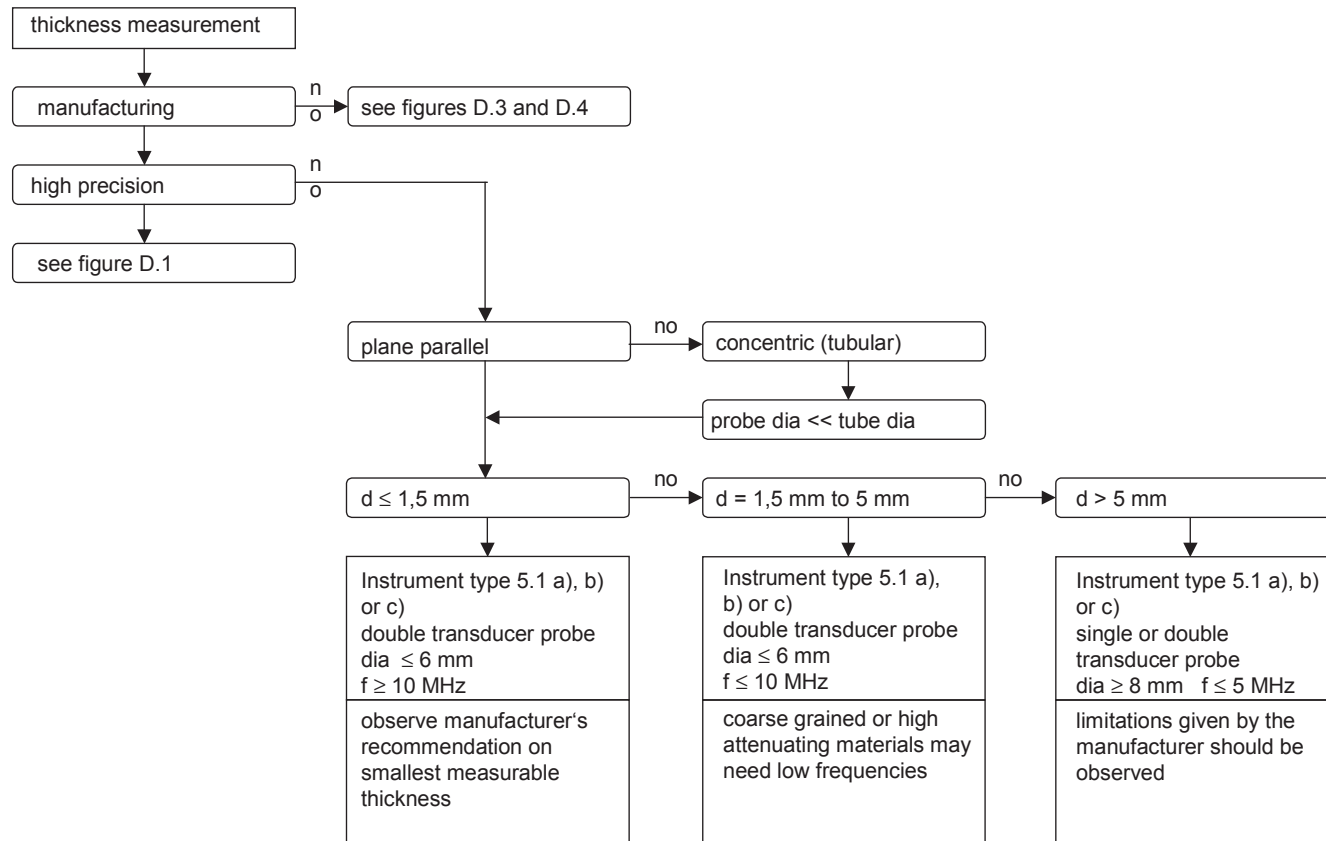

Figure D.2 — Flow chart for manufacturing inspection

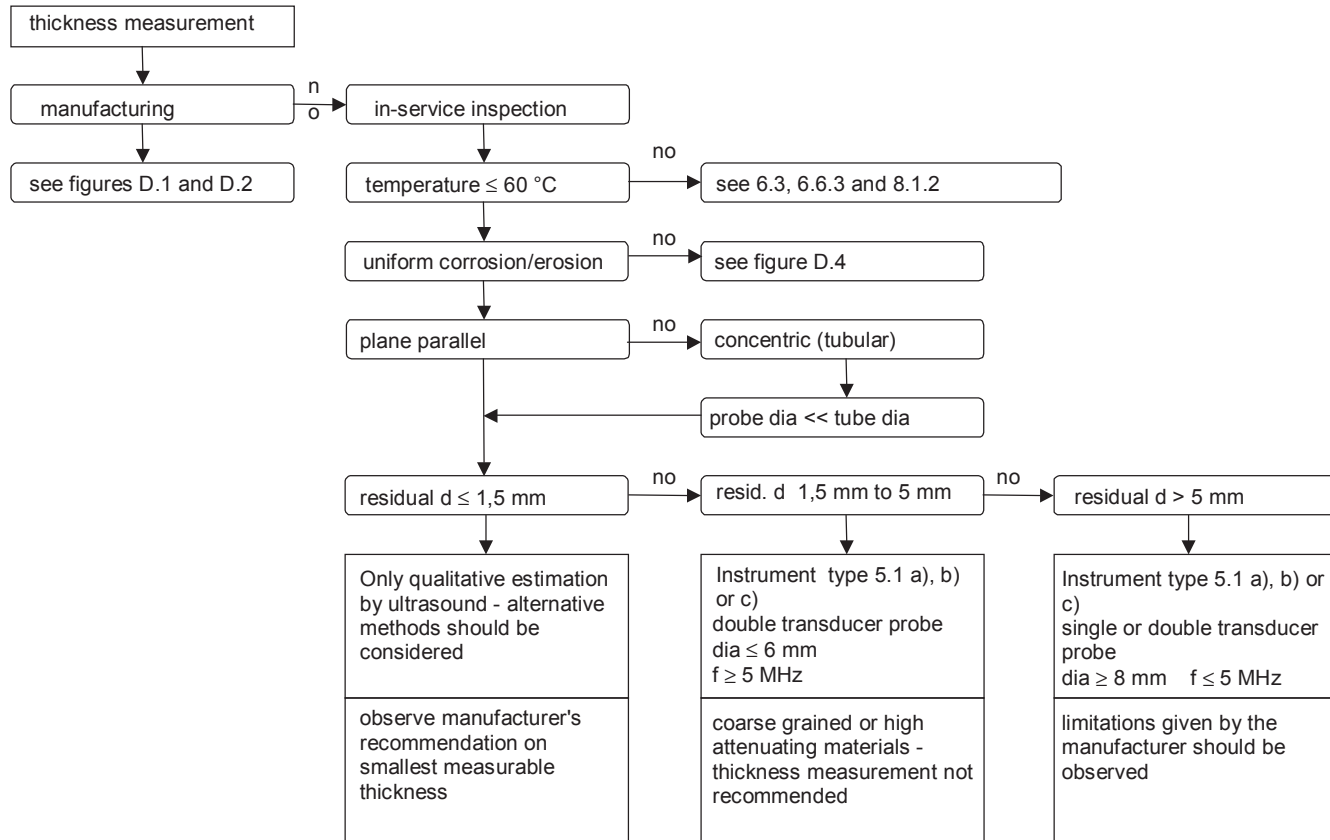

Figure D.3 — Flow chart for in-service inspection

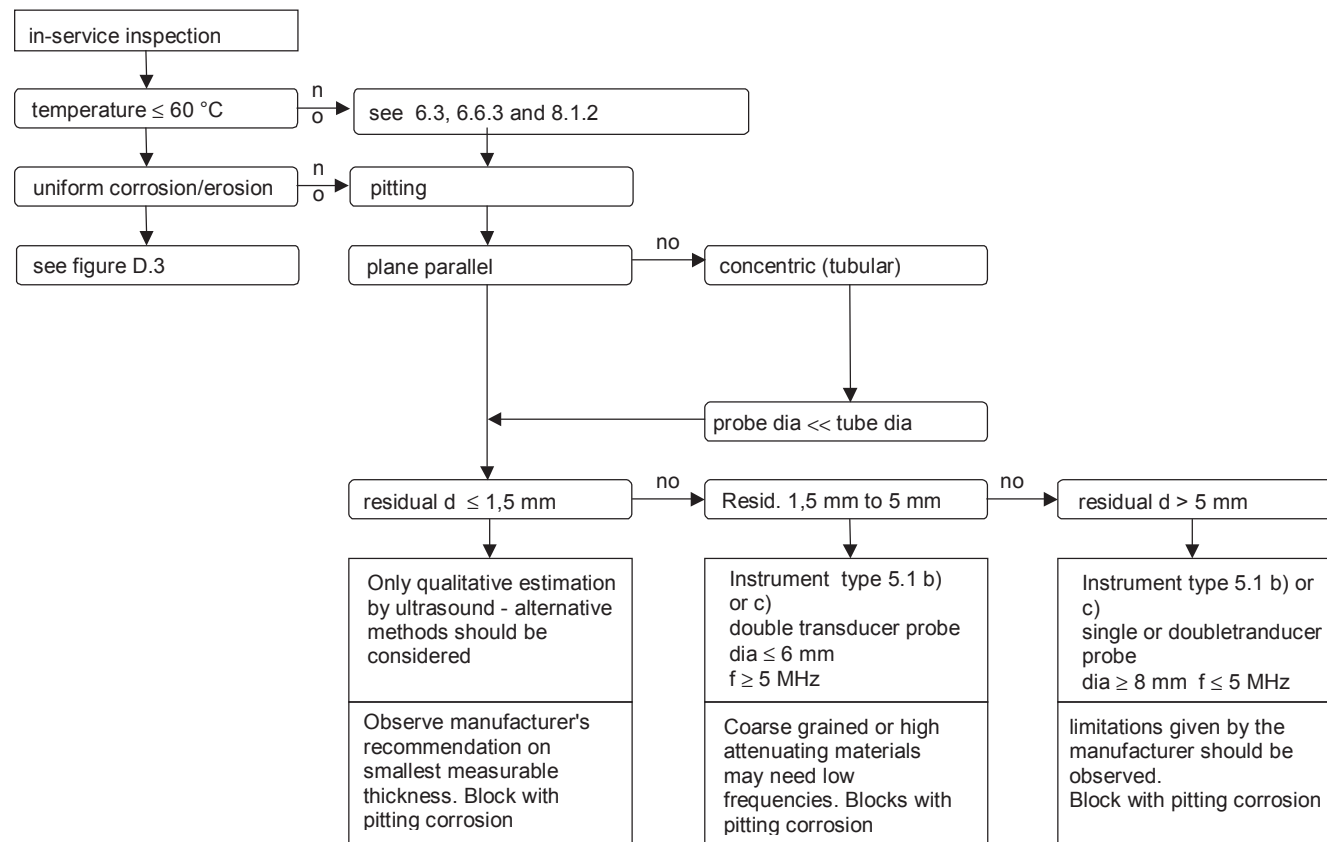

Figure D.4 — Flow chart for in-service inspection

Bibliography

- [1] EN 473, *Non-destructive testing — Qualification and certification of NDT personnel — General principles*

British Standards Institution (BSI)

BSI is the national body responsible for preparing British Standards and other standards-related publications, information and services.

BSI is incorporated by Royal Charter. British Standards and other standardization products are published by BSI Standards Limited.

About us

We bring together business, industry, government, consumers, innovators and others to shape their combined experience and expertise into standards-based solutions.

The knowledge embodied in our standards has been carefully assembled in a dependable format and refined through our open consultation process. Organizations of all sizes and across all sectors choose standards to help them achieve their goals.

Information on standards

We can provide you with the knowledge that your organization needs to succeed. Find out more about British Standards by visiting our website at bsigroup.com/standards or contacting our Customer Services team or Knowledge Centre.

Buying standards

You can buy and download PDF versions of BSI publications, including British and adopted European and international standards, through our website at bsigroup.com/shop, where hard copies can also be purchased.

If you need international and foreign standards from other Standards Development Organizations, hard copies can be ordered from our Customer Services team.

Subscriptions

Our range of subscription services are designed to make using standards easier for you. For further information on our subscription products go to bsigroup.com/subscriptions.

With **British Standards Online (BSOL)** you'll have instant access to over 55,000 British and adopted European and international standards from your desktop. It's available 24/7 and is refreshed daily so you'll always be up to date.

You can keep in touch with standards developments and receive substantial discounts on the purchase price of standards, both in single copy and subscription format, by becoming a **BSI Subscribing Member**.

PLUS is an updating service exclusive to BSI Subscribing Members. You will automatically receive the latest hard copy of your standards when they're revised or replaced.

To find out more about becoming a BSI Subscribing Member and the benefits of membership, please visit bsigroup.com/shop.

With a **Multi-User Network Licence (MUNL)** you are able to host standards publications on your intranet. Licences can cover as few or as many users as you wish. With updates supplied as soon as they're available, you can be sure your documentation is current. For further information, email bsmusales@bsigroup.com.

BSI Group Headquarters

389 Chiswick High Road London W4 4AL UK

Revisions

Our British Standards and other publications are updated by amendment or revision.

We continually improve the quality of our products and services to benefit your business. If you find an inaccuracy or ambiguity within a British Standard or other BSI publication please inform the Knowledge Centre.

Copyright

All the data, software and documentation set out in all British Standards and other BSI publications are the property of and copyrighted by BSI, or some person or entity that owns copyright in the information used (such as the international standardization bodies) and has formally licensed such information to BSI for commercial publication and use. Except as permitted under the Copyright, Designs and Patents Act 1988 no extract may be reproduced, stored in a retrieval system or transmitted in any form or by any means – electronic, photocopying, recording or otherwise – without prior written permission from BSI. Details and advice can be obtained from the Copyright & Licensing Department.

Useful Contacts:

Customer Services

Tel: +44 845 086 9001

Email (orders): orders@bsigroup.com

Email (enquiries): cservices@bsigroup.com

Subscriptions

Tel: +44 845 086 9001

Email: subscriptions@bsigroup.com

Knowledge Centre

Tel: +44 20 8996 7004

Email: knowledgecentre@bsigroup.com

Copyright & Licensing

Tel: +44 20 8996 7070

Email: copyright@bsigroup.com



...making excellence a habit.™