

Resilient floor coverings — Specification for floor panels for loose laying

ICS 97.150

National foreword

This British Standard is the UK implementation of EN 14085:2010. It supersedes BS EN 14085:2003 which is withdrawn.

The UK participation in its preparation was entrusted to Technical Committee PRI/3/60, Textile & Resilient Floor Coverings.

A list of organizations represented on this committee can be obtained on request to its secretary.

This publication does not purport to include all the necessary provisions of a contract. Users are responsible for its correct application.

Compliance with a British Standard cannot confer immunity from legal obligations.

This British Standard was published under the authority of the Standards Policy and Strategy Committee on 31 May 2010

© BSI 2010

ISBN 978 0 580 60398 3

Amendments/corrigenda issued since publication

Date	Comments

EUROPEAN STANDARD

EN 14085

NORME EUROPÉENNE

EUROPÄISCHE NORM

April 2010

ICS 97.150

Supersedes EN 14085:2003

English Version

Resilient floor coverings - Specification for floor panels for loose laying

Revêtements de sol résilients - Spécification des panneaux de plancher pour pose flottante

Elastische Bodenbeläge - Spezifikation für Fußbodenpaneele für lose Verlegung

This European Standard was approved by CEN on 27 February 2010.

CEN members are bound to comply with the CEN/CENELEC Internal Regulations which stipulate the conditions for giving this European Standard the status of a national standard without any alteration. Up-to-date lists and bibliographical references concerning such national standards may be obtained on application to the CEN Management Centre or to any CEN member.

This European Standard exists in three official versions (English, French, German). A version in any other language made by translation under the responsibility of a CEN member into its own language and notified to the CEN Management Centre has the same status as the official versions.

CEN members are the national standards bodies of Austria, Belgium, Bulgaria, Croatia, Cyprus, Czech Republic, Denmark, Estonia, Finland, France, Germany, Greece, Hungary, Iceland, Ireland, Italy, Latvia, Lithuania, Luxembourg, Malta, Netherlands, Norway, Poland, Portugal, Romania, Slovakia, Slovenia, Spain, Sweden, Switzerland and United Kingdom.



EUROPEAN COMMITTEE FOR STANDARDIZATION
COMITÉ EUROPÉEN DE NORMALISATION
EUROPÄISCHES KOMITEE FÜR NORMUNG

Management Centre: Avenue Marnix 17, B-1000 Brussels

© 2010 CEN All rights of exploitation in any form and by any means reserved worldwide for CEN national Members.

Ref. No. EN 14085:2010: E

Contents

Page

Foreword.....	3
1 Scope	4
2 Normative references	4
3 Terms and definitions	5
4 Requirements	5
4.1 General requirements for the floor panels	5
4.2 Resilient floor coverings	7
4.3 General requirements for the surface layer	7
4.3.1 General.....	7
4.3.2 Residual indentation	7
4.3.3 Colour fastness to artificial light.....	7
4.3.4 Hardness of rubber surface	7
4.4 Classification requirements.....	7
4.4.1 General.....	7
4.4.2 Classification requirements for the surface layer	9
5 Marking and packaging	9
5.1 Marking	9
5.2 Packaging	10
Annex A (normative) Determination of flatness.....	11
A.1 Sampling	11
A.2 Conditioning.....	11
A.3 Apparatus	11
A.3.1 Dial gauge	11
A.3.2 Rigid surface	11
A.3.3 Thickness gauge.....	11
A.4 Procedure	12
A.4.1 Determination of width flatness (f_w).....	12
A.4.2 Determination of length flatness (f_l).....	13
A.5 Recording and expression of results	14
A.5.1 General.....	14
Annex B (normative) Determination of openings and height differences between floor panels	15
B.1 Sampling	15
B.2 Conditioning.....	15
B.3 Apparatus	15
B.3.1 Thickness gauges.....	15
B.3.2 Calliper gauge	15
B.3.3 Test surface	15
B.4 Procedure	15
B.4.1 Assembly	15
B.4.2 Determination of openings between panels	16
B.4.3 Determination of height difference	16
B.5 Calculation and expression of results.....	16
Annex C (normative) Determination of dimensional variations caused by changes in humidity	17
C.1 General.....	17
C.2 Sampling.....	17
C.3 Conditioning.....	17
C.4 Procedure	18
C.5 Calculation and expression of results.....	18
Annex D (normative) Test report for tests carried out in accordance with Annexes A, B and C	19
Annex E (informative) Optional properties	20
Bibliography	21

Foreword

This document (EN 14085:2010) has been prepared by Technical Committee CEN/TC 134 “Resilient, textile and laminate floor coverings”, the secretariat of which is held by BSI.

This European Standard shall be given the status of a national standard, either by publication of an identical text or by endorsement, at the latest by October 2010, and conflicting national standards shall be withdrawn at the latest by October 2010.

Attention is drawn to the possibility that some of the elements of this document may be the subject of patent rights. CEN [and/or CENELEC] shall not be held responsible for identifying any or all such patent rights.

This document supersedes EN 14085:2003.

According to the CEN/CENELEC Internal Regulations, the national standards organizations of the following countries are bound to implement this European Standard: Austria, Belgium, Bulgaria, Croatia, Cyprus, Czech Republic, Denmark, Estonia, Finland, France, Germany, Greece, Hungary, Iceland, Ireland, Italy, Latvia, Lithuania, Luxembourg, Malta, Netherlands, Norway, Poland, Portugal, Romania, Slovakia, Slovenia, Spain, Sweden, Switzerland and the United Kingdom.

1 Scope

This European Standard specifies requirements and test methods for floor panels, which have surface layers consisting of resilient floor covering. The floor panels are considered suitable for domestic and commercial levels of use.

This European Standard is not applicable to floor panels that are subject to frequent wetting, such as bathrooms, laundry rooms and saunas.

This European Standard also specifies the requirements for marking and packaging.

2 Normative references

The following referenced documents are indispensable for the application of this document. For dated references only the edition cited applies. For undated references the latest edition of the referenced document (including any amendments) applies.

EN 309:2005, *Particleboards – Definition and classification*

EN 316:2009, *Wood fibre boards – Definition, classification and symbols*

EN 424, *Resilient floor coverings – Determination of the effect of simulated movement of a furniture leg*

EN 425, *Resilient and laminate floor coverings – Castor chair test*

EN 427, *Resilient floor coverings – Determination of the side length, squareness and straightness of tiles*

EN 428, *Resilient floor coverings – Determination of overall thickness*

EN 548, *Resilient floor coverings – Specification for plain and decorative linoleum*

EN 649, *Resilient floor coverings – Homogeneous and heterogeneous polyvinyl chloride floor coverings – Specification*

EN 651, *Resilient floor coverings — Polyvinyl chloride floor coverings with foam layer – Specification*

EN 652, *Resilient floor coverings – Polyvinyl chloride floor coverings with cork-based backing – Specification*

EN 653, *Resilient floor coverings – Expanded (cushioned) polyvinyl chloride floor coverings – Specification*

EN 655, *Resilient floor coverings – Tiles of agglomerated composition cork with polyvinyl chloride wear layer – Specification*

EN 669:1997, *Resilient floor coverings – Determination of dimensional stability of linoleum tiles caused by changes in atmospheric humidity*

EN 685, *Resilient, textile and laminate floor coverings - Classification*

EN 1817, *Resilient floor coverings – Specification for homogeneous and heterogeneous smooth rubber floor coverings*

EN 12104, *Resilient floor coverings – Cork floor tiles – Specification*

EN 12199, *Resilient floor coverings – Specifications for homogeneous and heterogeneous relief rubber floor coverings*

EN 12466:1998, *Resilient floor coverings – Vocabulary*

EN 13845, *Resilient floor coverings – Polyvinyl chloride floor coverings with particle based enhanced slip resistance – Specification*

EN 14565, *Resilient floor coverings – Floor coverings based upon synthetic thermoplastic polymers – Specification*

ISO 24336, *Laminate floor coverings – Determination of thickness swelling after partial immersion in water*

3 Terms and definitions

For the purposes of this document, the terms and definitions given in EN 309:2005, EN 316:2009, EN 12466:1998 and the following apply.

3.1

floor panel

product generally of rectangular form consisting of a compact layer of a substrate and a surface layer of a resilient floor covering

3.2

substrate

core material of the floor panel, which is tongued and grooved or otherwise constructed to allow the panels to be assembled together using an appropriate glue or by other assembling techniques.

NOTE 1 The substrate might include a backing.

NOTE 2 The substrate is generally a particleboard, as defined in EN 309, or a Medium Density Fibreboard or High Density Fibreboard (MDF or HDF) as defined in EN 316.

3.3

surface layer

upper decorative layer of one of the specified resilient floor coverings, which is bonded to the substrate directly or as total product and is intended to be the visible side when the floor is installed.

4 Requirements

4.1 General requirements for the floor panels

All classes of floor panels including the surface layer shall conform to the requirements specified in Table 1 when tested in accordance with the test methods specified in Table 1.

Table 1 — General requirements for the floor panels

Property	Requirement	Test method
Dimensions measured at the surface layer Square panels Side length % Rectangular panels Width % Length mm	Maximum deviation from the nominal ± 0,10, with max. 0,5 mm ± 0,10, with max. 0,5 mm max. 2,0	EN 427 ^a
Overall thickness Average mm Individual values mm	Nominal ± 0,25 Maximum deviation from the average ± 0,30	EN 428
Squareness mm	≤ 0,50	EN 427
Straightness measured at the surface layer mm	≤ 0,30	EN 427
Flatness of the panel Length Concave / convex % of the length Width Concave / convex % of the width	≤ 0,50 / ≤ 1,0 ≤ 0,10 / ≤ 0,15	Annex A
Openings between panels Average mm Individual values mm	≤ 0,15 ≤ 0,20	Annex B
Height difference between panels ^b Average mm Individual values mm	≤ 0,15 ≤ 0,20	Annex B
Dimensional variation caused by changes in atmospheric humidity %	≤ 5	Annex C / EN 669
^a For length > 0,5 m a metal ruler may be used. ^b Only to be tested when required for the assembling system.		

4.2 Resilient floor coverings

The surface layer shall comply with the relevant standards below:

- linoleum floor covering as defined in EN 548;
- rubber floor covering as defined in EN 1817 and EN 12199;
- polyvinyl chloride floor covering as defined in EN 649, EN 651, EN 652, EN 653 and EN 655;
- cork floor covering as defined in EN 12104;
- synthetic thermoplastic polymer floor covering as defined in EN 14565;
- polyvinyl chloride floor coverings with particle based enhanced slip resistance as defined in EN 13845.

4.3 General requirements for the surface layer

4.3.1 General

All classes of floor panels with a resilient surface shall conform to the appropriate general requirements as specified below.

4.3.2 Residual indentation

The residual indentation shall be in accordance with the requirements established in the corresponding specification standard as listed in 3.3 taking into account the surface or wear layer thickness classes in that same standard in relation to Table 2.

4.3.3 Colour fastness to artificial light

The colour fastness to artificial light shall be in accordance with the requirements for the surface or wear layer established in the corresponding specification standard as listed in 3.3.

4.3.4 Hardness of rubber surface

The hardness of a surface consisting of rubber floor covering as specified in EN 1817 shall be in accordance with the requirement in that same standard.









4.4 Classification requirements

4.4.1 General

The floor panels shall be classified in accordance with EN 685. The panels shall conform to the requirements of Table 2 for their class, regardless of the type of surface layer that they have.

NOTE The requirements for each class are related to the effect of a furniture leg and castor chair and the thickness swelling after partial immersion in water.

Table 2 — Classification requirements for floor panels

Class	Symbol	Intensity of use	Effect of a furniture leg ^a	Effect of a castor chair	Thickness swelling floor panel
		Domestic			
21		Moderate/Light	No Requirement	No Requirement	≤ 20 %
22		General/Medium			
22+		General			
23		Heavy			
		Commercial			
31		Moderate	No damage shall be visible when tested with foot type 0	No disturbance to the surface other than slight change in appearance and no delaminating shall occur	≤ 18 %
32		General			
33 ^b		Heavy			≤ 15 %
34 ^b		Very Heavy			
Test method			EN 424	EN 425	ISO 24336
^a For panels with a Cork surface the requirements for the furniture leg in EN 12104 shall be considered. ^b Panels with a cork surface are not suitable for use in this class; see also Table 3.					

4.4.2 Classification requirements for the surface layer

4.4.2.1 General

The surface layer shall be classified in accordance with EN 685.

NOTE The classification depends on the type of floor covering used

4.4.2.2 Linoleum surface layer

Floor panels with a linoleum surface layer shall conform to the classification requirements of the surface layer thickness as specified in EN 548.

4.4.2.3 Rubber surface layer

Floor panels with a rubber surface layer shall conform to the classification requirements of the surface layer thickness as specified in EN 1817 and EN 12199.

4.4.2.4 Polyvinyl Chloride surface layer

Floor panels with a polyvinyl chloride surface layer shall conform to the classification requirements of the wear layer thickness in combination with the corresponding wear group as specified in EN 649; EN 651; EN 652; EN 653 and EN 655.

4.4.2.5 Polyvinyl Chloride with enhanced slip properties surface layer

Floor panels with a polyvinyl chloride with enhanced slip properties surface layer shall conform to the classification requirements of the nominal thickness in combination with the corresponding wear resistance as specified in EN 13845.

4.4.2.6 Synthetic thermoplastic polymer surface layer

Floor panels with a synthetic thermoplastic polymer surface layer shall conform to the classification requirements as specified in EN 14565.

4.4.2.7 Cork surface layer

Floor panels with a cork surface layer shall conform to the classification requirements as specified in EN 12104 and the nominal thickness shall be as specified in Table 3.

Table 3 — Nominal thickness for cork surfaces

Class	Nominal thickness
21, 22 and 23	≥ 2,5 mm
31 and 32	≥ 3,0 mm

5 Marking and packaging

5.1 Marking

Floor panels manufactured and conforming to this specification shall show the following information clearly on a label on or in the package:

- a) number and date of this European Standard, i.e. EN 14085:2010;

- b) manufacturer's or supplier's identification;
- c) product name
- d) class / symbol of level of use according to EN 685;
- e) year of manufacture (last two digits);
- f) colour / pattern and batch number;
- g) successive number of the package if necessary for the installation;
- h) nominal dimensions of the panel;
- i) number of panels contained in the package;
- j) covered floor area after installation per package;
- k) warning requirement that packages shall be stored shielded from direct sunlight and humidity.

5.2 Packaging

Floor panels shall be delivered in packages designed to protect the corners, edges and surfaces of the product, under normal conditions of transport and handling. The product shall be accompanied by installation, cleaning and maintenance instructions.

Annex A (normative)

Determination of flatness

A.1 Sampling

From the available material five floor panels shall be taken as specimens.

A.2 Conditioning

Test specimens are measured in the received state. For type approval or verification purposes, the test specimens shall be stabilized to a constant mass in an atmosphere of (23 ± 2) °C and (50 ± 5) % relative humidity. Constant mass is considered to be reached when the results of two successive weighing operations, carried out at an interval of 24 h, do not differ by more than 0,1 % of the mass of the test specimens..

A.3 Apparatus

A.3.1 Dial gauge

Apparatus for measuring width flatness consisting of a dial gauge accurate to $\pm 0,01$ mm with a rounded tip of radius δ 5,5 mm, installed centrally in relation to three rounded supports with radii ϵ 5 mm. The supports shall be adjustable along a T-shaped assembly of bars to provide the required gauge length. The measurement d shall not be less than the width w of the test specimen minus 10 mm. The tip of the gauge in contact with the face of the test specimen shall apply a force of $(1,0 \pm 0,5)$ N. The mass of the apparatus shall not affect the flatness of the test specimen beyond the limit of the accuracy of the gauge. See Figure A.1 for illustration. The instrument shall be set to zero against a suitable reference plate.

A.3.2 Rigid surface

A plain rigid surface, at least as long as the floor panel, having a maximum straightness deviation of 0,05 mm over 1 000 mm..

A.3.3 Thickness gauge

A feeler thickness gauge or sliding calliper, or equivalent tool to measure the deviation between the plate and the floor panel to an accuracy of 0,05 mm.

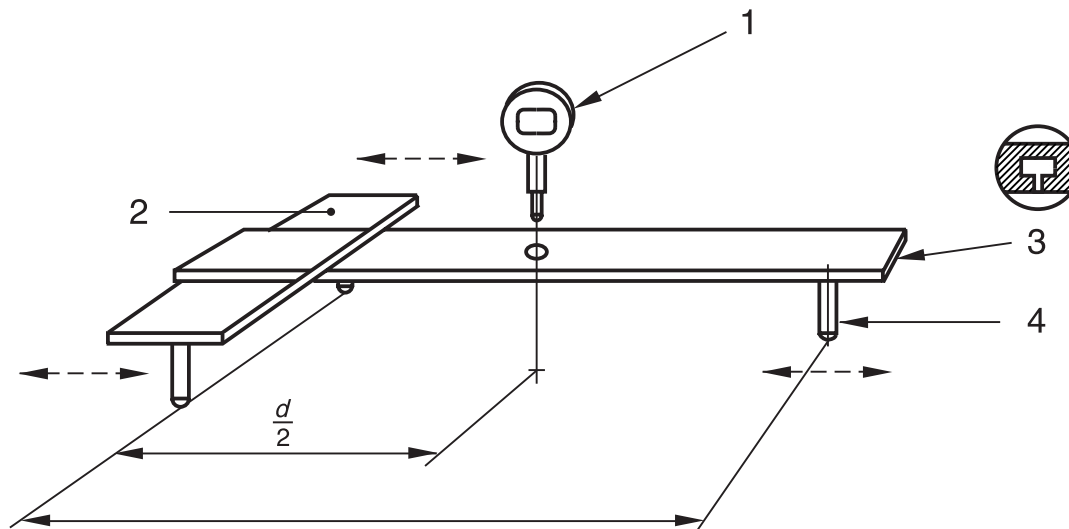

Key

- 1 dial gauge
- 2 T-groove
- 3 adjustable pin
- 4 adjustable bridge

Figure A.1 — Example of instrument for measuring width flatness

A.4 Procedure

A.4.1 Determination of width flatness (f_w)

Adjust the supports along the T-shaped assembly of bars according to the width of the test specimen to evaluate (see Figure A.2). Determine the maximum deviation f_w for each element. The measurement d shall not be less than the width w of the test specimen minus 10 mm..

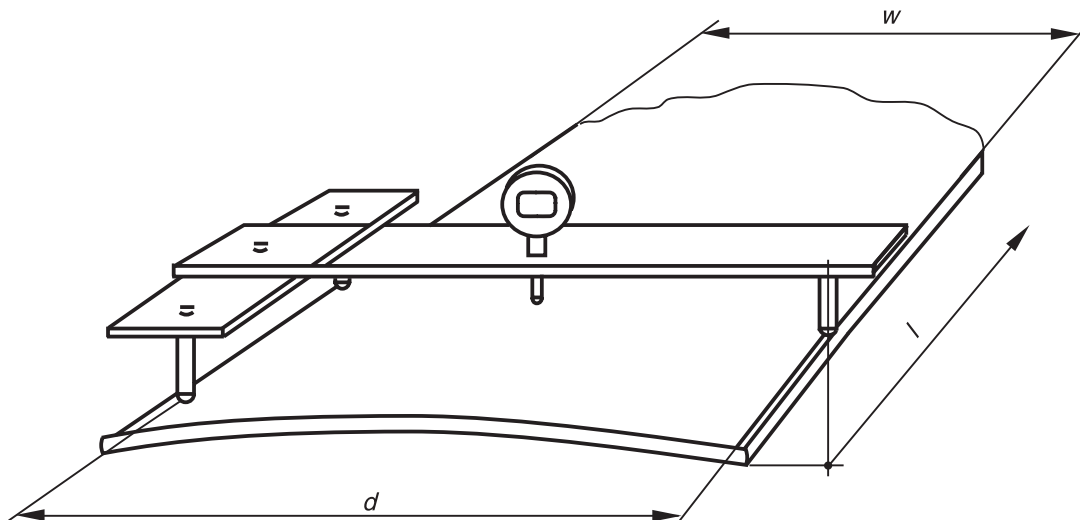
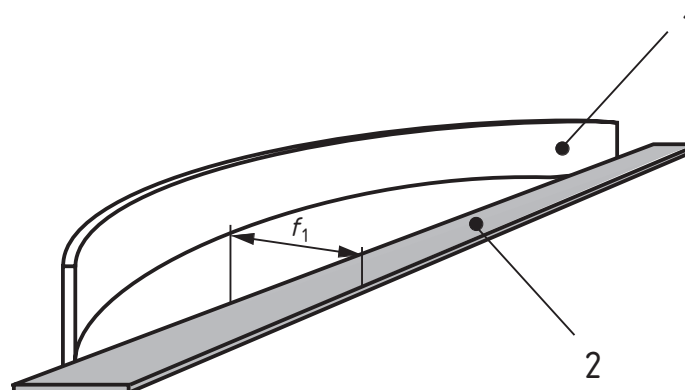

Figure A.2 — Determination of width flatness

A.4.2 Determination of length flatness (f)

Place the test specimen against the steel ruler as shown in Figure A.3. Using the thickness gauges or the caliper gauge, determine the maximum deviation f_1 from the ruler for each element. The measured value shall be expressed as concave when the surface layer is facing towards the ruler and as convex when the surface layer is facing away from the ruler.



Key

- 1 test specimen
- 2 steel ruler

Figure A.3 — Determination of length flatness

A.5 Recording and expression of results

A.5.1 General

Report if the samples were conditioned before the test was performed.

A.5.2 Width flatness (f_w)

Record all measured values f_w and take the largest convex and concave values and divide each by the measurement d (see A.3.5). Express the results to the nearest 0,01 %.

A.5.3 Length flatness (f_l)

Record all measured values f_l and take the largest convex and concave values and divide each by the nominal length of the element. Express the result to the nearest 0,01 %.

Annex B (normative)

Determination of openings and height differences between floor panels

B.1 Sampling

Take 8 laminate floor-covering elements as test specimens.

B.2 Conditioning

Test specimens are measured in the received state. For type approval or verification purposes, the test specimens shall be stabilized to a constant mass in an atmosphere of (23 ± 2) °C and (50 ± 5) % relative humidity. Constant mass is considered to be reached when the results of two successive weighing operations, carried out at an interval of 24 h, do not differ by more than 0,1 % of the mass of the test specimens.

B.3 Apparatus

B.3.1 Thickness gauges

Set of thickness gauges ranging from 0,05 mm to 0,10 mm in steps of 0,01 mm, and from 0,10 mm to 0,50 mm in steps of 0,05 mm.

B.3.2 Calliper gauge

Calliper gauge or a depth gauge, with a scale interval of 0,05 mm.

B.3.3 Test surface

Test surface of appropriate size that is rigid, horizontal and flat.

B.4 Procedure

B.4.1 Assembly

By hand force, firmly assemble the test specimens on the test surface without using any glue, as in Figure B.1, using the ruler as a guide. The symbol ▼ indicates 11 measuring points

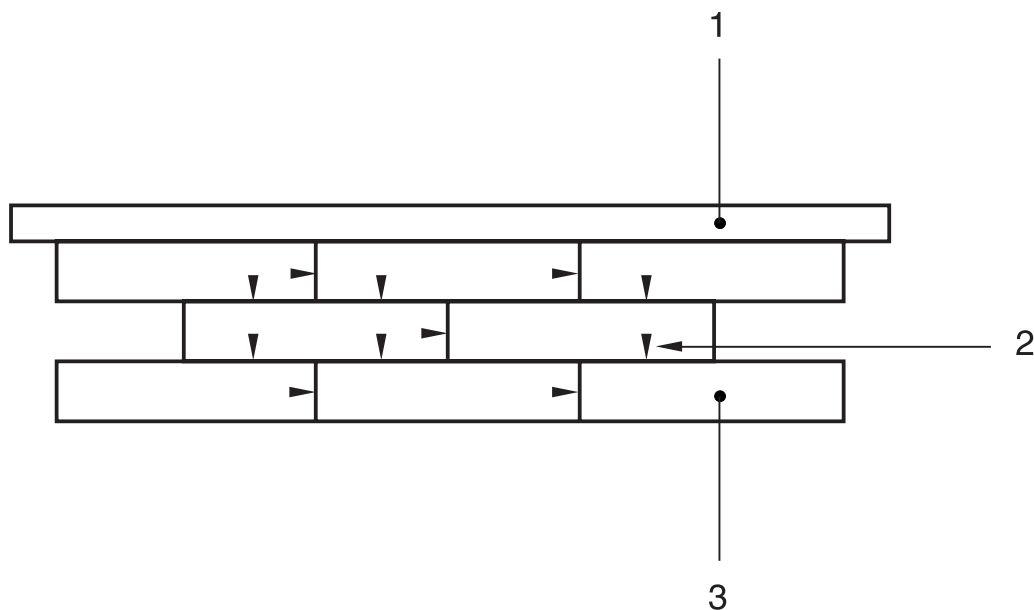

Key

- 1 steel ruler
- 2 measuring point
- 3 test specimen

Figure B.1 — Test panels assembled, with indicated measuring points

B.4.2 Determination of openings between panels

Using the thickness gauges, measure the openings, without applying any force to the panels, at the 11 indicated points.

B.4.3 Determination of height difference

Using the calliper or depth gauge, measure the height differences, without applying any force to the panels at the 11 indicated points. Place the base of the instrument at one side of the joint, and measure the maximum height difference at the other side of the joint. Do not carry out the measurement further than 5 mm from the joint edge.

B.5 Calculation and expression of results

Calculate the mean value for the 11 opening thickness measurements and for the 11 height difference measurements. Record the maximum individual value for both properties. Express the results in millimetres to the nearest 0,05 mm.

Annex C (normative)

Determination of dimensional variations caused by changes in humidity

C.1 General

Test in accordance with EN 669, with the following modifications.

C.2 Sampling

Take from each of three floor panels one test specimen in the length direction and another in the width direction. The test specimens may be taken from any part of the element as long as the length direction and width direction is maintained (see Figure C.1). The dimension of a test specimen shall be (180 ± 1) mm x (20 ± 1) mm. If the nominal width of the element is less than 180 mm, no test specimen in the width direction shall be taken.

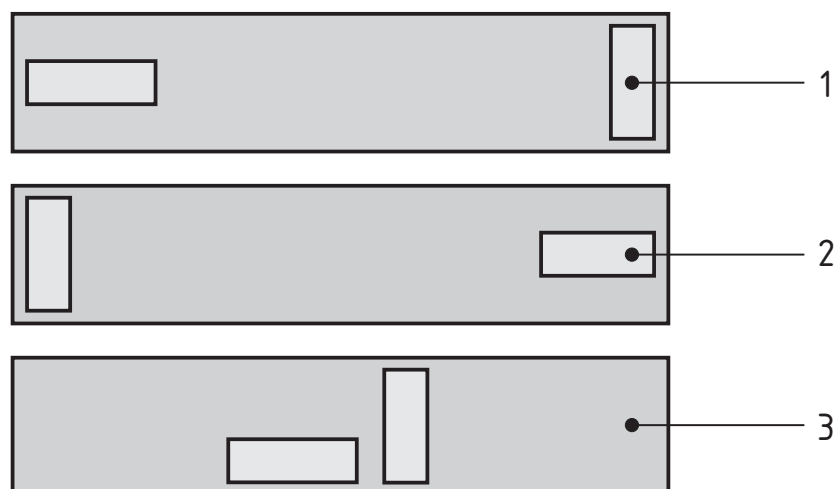

Key

- 1 test specimen taken in the width direction
- 2 test specimen taken in the length direction
- 3 laminate floor covering element

Figure C.1 — Example of sampling

C.3 Conditioning

The test specimens shall be stabilized to a constant mass in an atmosphere of (23 ± 2) °C and (50 ± 5) % relative humidity. Constant mass is considered to be reached when the results of two successive weighing operations, carried out at an interval of 24 h, do not differ by more than 0,1 % of the mass of the test specimens.

C.4 Procedure

Measure the width and the length of the specimens at the marks in accordance with EN 669. Carry out the test in accordance with Clause 6 of EN 669:1997.

C.5 Calculation and expression of results

Only the variation in length and width of the test specimens shall be determined. Determine the dimensional variations for length and width direction for each specimen between 50 % RH and 80 % RH in accordance with EN 669. Calculate the average length variation and the average width variation respectively. Express the results as a percentage to the nearest 0,1 %.

Annex D (normative)

Test report for tests carried out in accordance with Annexes A, B and C

The test report shall include at least the following information:

- a) reference to this standard, i.e. EN 14085 and the specification for the surface layer;
- b) complete identification of the product tested including type, source and manufacturer's reference number;
- c) previous history of the sample;
- d) number of panels tested;
- e) test results;
- f) any deviation from the test methods which may have affected the results.

Annex E (informative)

Optional properties

Where the following properties are required for specific applications, the floor panels may be tested in accordance with the following methods, as appropriate:

Electrostatic propensity, EN 1815;

Effect of stains, EN 423;

Moisture content of agglomerated cork at dispatch from the manufacturer, EN 12105.

Bibliography

- [1] EN 423, *Resilient floor coverings – Determination of resistance to staining*
- [2] EN 429, *Resilient floor coverings – Determination of the thickness of layers*
- [3] EN 430, *Resilient floor coverings – Determination of mass per unit area*
- [4] EN 1815, *Resilient and textile floor coverings – Assessment of static electrical propensity*
- [5] EN 12105, *Resilient floor coverings – Determination of moisture content of agglomerated composition cork*
- [6] EN 433, *Resilient floor coverings – Determination of residual indentation after static loading*

BSI - British Standards Institution

BSI is the independent national body responsible for preparing British Standards. It presents the UK view on standards in Europe and at the international level. It is incorporated by Royal Charter.

Revisions

British Standards are updated by amendment or revision. Users of British Standards should make sure that they possess the latest amendments or editions.

It is the constant aim of BSI to improve the quality of our products and services. We would be grateful if anyone finding an inaccuracy or ambiguity while using this British Standard would inform the Secretary of the technical committee responsible, the identity of which can be found on the inside front cover. Tel: +44 (0)20 8996 9000. Fax: +44 (0)20 8996 7400.

BSI offers members an individual updating service called PLUS which ensures that subscribers automatically receive the latest editions of standards.

Buying standards

Orders for all BSI, international and foreign standards publications should be addressed to Customer Services. Tel: +44 (0)20 8996 9001. Fax: +44 (0)20 8996 7001 Email: orders@bsigroup.com You may also buy directly using a debit/credit card from the BSI Shop on the Website <http://www.bsigroup.com/shop>

In response to orders for international standards, it is BSI policy to supply the BSI implementation of those that have been published as British Standards, unless otherwise requested.

Information on standards

BSI provides a wide range of information on national, European and international standards through its Library and its Technical Help to Exporters Service. Various BSI electronic information services are also available which give details on all its products and services. Contact Information Centre. Tel: +44 (0)20 8996 7111 Fax: +44 (0)20 8996 7048 Email: info@bsigroup.com

Subscribing members of BSI are kept up to date with standards developments and receive substantial discounts on the purchase price of standards. For details of these and other benefits contact Membership Administration. Tel: +44 (0)20 8996 7002 Fax: +44 (0)20 8996 7001 Email: membership@bsigroup.com

Information regarding online access to British Standards via British Standards Online can be found at <http://www.bsigroup.com/BSOL>

Further information about BSI is available on the BSI website at <http://www.bsigroup.com>.

Copyright

Copyright subsists in all BSI publications. BSI also holds the copyright, in the UK, of the publications of the international standardization bodies. Except as permitted under the Copyright, Designs and Patents Act 1988 no extract may be reproduced, stored in a retrieval system or transmitted in any form or by any means – electronic, photocopying, recording or otherwise – without prior written permission from BSI.

This does not preclude the free use, in the course of implementing the standard, of necessary details such as symbols, and size, type or grade designations. If these details are to be used for any other purpose than implementation then the prior written permission of BSI must be obtained.

Details and advice can be obtained from the Copyright and Licensing Manager. Tel: +44 (0)20 8996 7070 Email: copyright@bsigroup.com