

BS EN 14043:2014



BSI Standards Publication

**High rise aerial appliances  
for fire and rescue service  
use — Turntable ladders  
with combined movements  
— Safety and performance  
requirements and test methods**

**bsi.**

...making excellence a habit.™

**National foreword**

This British Standard is the UK implementation of EN 14043:2014. It supersedes BS EN 14043:2005+A1:2009 which is withdrawn.

The UK participation in its preparation was entrusted to Technical Committee FSH/17, Fire brigade equipment.

A list of organizations represented on this committee can be obtained on request to its secretary.

This publication does not purport to include all the necessary provisions of a contract. Users are responsible for its correct application.

© The British Standards Institution 2014. Published by BSI Standards Limited 2014

ISBN 978 0 580 72438 1

ICS 13.220.10

**Compliance with a British Standard cannot confer immunity from legal obligations.**

This British Standard was published under the authority of the Standards Policy and Strategy Committee on 31 January 2014.

**Amendments issued since publication**

Date	Text affected
------	---------------

---

EUROPEAN STANDARD

**EN 14043**

NORME EUROPÉENNE

EUROPÄISCHE NORM

January 2014

ICS 13.220.10

Supersedes EN 14043:2005+A1:2009

English Version

## High rise aerial appliances for fire and rescue service use - Turntable ladders with combined movements - Safety and performance requirements and test methods

Moyens élévateurs aériens à l'usage des services de secours et de lutte contre l'incendie - Echelles pivotantes à mouvements combinés - Prescriptions de sécurité et de performance et méthodes d'essais

Hubrettungsfahrzeuge für die Feuerwehr - Drehleitern mit kombinierten Bewegungen (Automatik-Drehleitern) - Sicherheits- und Leistungsanforderungen sowie Prüfverfahren

This European Standard was approved by CEN on 26 October 2013.

CEN members are bound to comply with the CEN/CENELEC Internal Regulations which stipulate the conditions for giving this European Standard the status of a national standard without any alteration. Up-to-date lists and bibliographical references concerning such national standards may be obtained on application to the CEN-CENELEC Management Centre or to any CEN member.

This European Standard exists in three official versions (English, French, German). A version in any other language made by translation under the responsibility of a CEN member into its own language and notified to the CEN-CENELEC Management Centre has the same status as the official versions.

CEN members are the national standards bodies of Austria, Belgium, Bulgaria, Croatia, Cyprus, Czech Republic, Denmark, Estonia, Finland, Former Yugoslav Republic of Macedonia, France, Germany, Greece, Hungary, Iceland, Ireland, Italy, Latvia, Lithuania, Luxembourg, Malta, Netherlands, Norway, Poland, Portugal, Romania, Slovakia, Slovenia, Spain, Sweden, Switzerland, Turkey and United Kingdom.



EUROPEAN COMMITTEE FOR STANDARDIZATION  
COMITÉ EUROPÉEN DE NORMALISATION  
EUROPÄISCHES KOMITEE FÜR NORMUNG

**CEN-CENELEC Management Centre: Avenue Marnix 17, B-1000 Brussels**

## Contents

Page

Foreword.....	4
Introduction .....	7
1 Scope .....	8
2 Normative references .....	8
3 Terms and definitions, symbols and abbreviated terms .....	9
4 List of significant hazards .....	17
5 Requirements .....	25
5.1 Safety requirements and/or measures .....	25
5.1.1 General.....	25
5.1.2 Requirements in respect of stability.....	26
5.1.3 Requirements relating to the strength of the turntable ladder .....	38
5.1.4 Verification of vehicle performance by functional testing .....	39
5.1.5 Requirements relating to function .....	41
5.1.6 Requirements relating to noise .....	68
5.2 Performance requirements .....	69
5.2.1 Operational requirements .....	69
5.2.2 Requirements demanded by national regulations .....	70
5.2.3 Overall maximum dimensions.....	70
5.2.4 Maximum gross laden mass.....	71
5.2.5 Radio interference .....	71
6 Designation .....	72
7 Information for use .....	72
7.1 General.....	72
7.2 Instruction handbook .....	73
7.2.1 General.....	73
7.2.2 Operating instruction .....	73
7.2.3 Transport, handling and storage information.....	74
7.2.4 Information on commissioning .....	75
7.2.5 Machine details .....	75
7.2.6 Maximum loads in the rescue cage and/or on the ladder set .....	75
7.2.7 Maintenance information for use by trained personnel.....	75
7.2.8 Special working methods or conditions .....	76
7.2.9 Periodical examinations and tests.....	76
7.3 Marking .....	76
Annex A (informative) Example of table recording the stability tests .....	79
Annex B (normative) Operating time.....	80
Annex C (informative) List of nominal reaches in several European countries applicable to turntable ladders.....	81
Annex D (informative) Verification and reception tests .....	83
Annex ZA (informative) Relationship between this European Standard and the Essential Requirements of EU Directive 2006/42/EC .....	87
Bibliography.....	88

## Figures

Figure 1 — Example of boundary .....	13
Figure 2 — Jacking width .....	14
Figure 3 — Designation of ladder set sections .....	16
Figure 4 — Example of forces acting on turntable ladder .....	27
Figure 5 — Resulting force of the working load.....	28
Figure 6 — Surface exposed to the wind .....	29
Figure 7 — Minimum required residual force related to jacking width.....	31
Figure 8 — Maximum and minimum jacking width.....	32
Figure 11 — Static tilt angle $\delta$ for turntable ladders .....	45
Figure 12 — Maximum angle of elevation.....	47
Figure 13 — Relative positions of hand and guard-rails.....	49
Figure 14 — Impact simulation on the rescue cage .....	53
Figure 15 — Rung alignment.....	60
Figure 16 — Minimum dimensions of ladder sections .....	63
Figure 17 — Rung spacing dimensions .....	63
Figure 18 — Winding diameter.....	67
Figure 19 — Diagram of minimum unaffected zones .....	72
Figure 20 — Example of a warning label for the number of person permissible in the rescue cage.....	77

## Tables

Table 1 — List of significant hazards .....	17
Table 2 — Safety factors for load calculations .....	29
Table 3 — Test cases for verification method 2.....	34
Table 4 — Functional Safety and Performance Level.....	53
Table 5 — Functional requirements for ladder set main control console .....	55
Table 6 — Dimensions .....	62
Table 7 — Determination of factor $c$ .....	65
Table 8 — Determination of factor $h_1$ for the following construction unit.....	66
Table 9 — Determination of factor $h_2$ for the following construction unit.....	67
Table 10 — Nominal reaches.....	70
Table 11 — Overall maximum dimensions in travel position .....	70
Table 12 — Maximum gross laden mass .....	71
Table 13 — Masses taken into consideration in the calculation of gross laden mass .....	71
Table A.1 — Example of table recording the stability tests .....	79
Table B.1 — Determination of the operating time .....	80
Table C.1 — Nominal reaches of turntable ladders in several European countries.....	81
Table D.1— Verifications and reception tests .....	83

## Foreword

This document (EN 14043:2014) has been prepared by Technical Committee CEN/TC 192 "Fire and rescue service equipment", the secretariat of which is held by BSI.

This European Standard shall be given the status of a national standard, either by publication of an identical text or by endorsement, at the latest by July 2014, and conflicting national standards shall be withdrawn at the latest by July 2014.

Attention is drawn to the possibility that some of the elements of this document may be the subject of patent rights. CEN [and/or CENELEC] shall not be held responsible for identifying any or all such patent rights.

This document supersedes EN 14043:2005+A1:2009.

This document has been prepared under a mandate given to CEN by the European Commission and the European Free Trade Association, and supports essential requirements of EU Directive(s).

For relationship with EU Directive(s), see informative Annex ZA, which is an integral part of this document.

The significant changes with respect to the previous edition of EN 14043 are listed below:

- a) ladder class > 30 to 56 added;
- b) terms and definitions for turntable ladder with combined movements, rescue height, supported boundary, jacking width and load per person reworded, for dead man's device, working position and boundary added and for special boundary of use deleted;
- c) calculation of the working load and of diverse force revised;
- d) fatigue stress analysis completely revised;
- e) static stability revised and depends on the jacking width with defined residual forces;
- f) verification of static stability and dynamic stability revised;
- g) functional requirements revised;
- h) requirement for audible alarm at low battery voltage added;
- i) verification relating to the strength of the turntable ladder at the boundary of free-standing use with  $\alpha_{\max}$  revised;
- j) verification relating to the strength of the turntable ladder at the boundary of free-standing use (without or with rescue cage) deleted;
- k) verification relating to turntable ladders constructed to be operated only with the rear axle suspension fully or partially locked revised;
- l) requirement that loaded ladder shall maintain its position for 10 min with a variation less than 150 mm added;
- m) at least 100 mm difference at relative positions for the suspension locking device added;
- n) static tilt angle added;

- o) requirements on hand and guard-rails of the rescue cage revised and a requirement relating to aperture size added;
- p) requirements for anchoring points in the rescue cage for personal protective equipment against falling added;
- q) requirements relating to access doors and door locking devices in the rescue cage fully revised;
- r) requirements and verification revised relating to attachment systems for turntable ladders with a removable rescue cage;
- s) working light requirements revised;
- t) safety related parts of the control system according to category 1 or 2 of EN 954-1 changed to performance level (PL) according to EN ISO 13849-1;
- u) general normative reference to CEN/TS 15989 for the symbols on the control console added and all figures and tables with symbols deleted;
- v) requirements for the main control console added, that movement via the control lever of the rescue cage control console shall only take place after unlocking the emergency stop control in the rescue cage;
- w) indicator (e. g. display) to show the actual values of ladder length, ladder extension and elevation angle together with the maximum achievable values added;
- x) requirement revised relating to access from the ground to the ladder set (either directly (e.g. access ladder) or indirectly (e.g. deck));
- y) voice communication revised;
- z) rung alignment revised;
- aa) requirement revised relating to transmission systems (safety factors) and cable drums (grooves or devices preventing the cable running off the drum);
- bb) safety requirements related to electromagnetic phenomena and requirements relating to noise revised;
- cc) recommendation to use dependability management systems added;
- dd) precision of designation;
- ee) instruction handbook revised;
- ff) list of all known nominal reaches in several European countries applicable to turntable ladders in Annex C added;
- gg) list of verification and reception tests in Annex D with short description of requirement/test added;
- hh) Annex ZA deleted relating to the relationship between this European Standard and the Essential Requirements of the replaced EU Directive 98/37/EC;
- ii) Normative references revised: withdrawn standards EN 418, EN 457, EN 954-1, EN 982, EN 1050, EN ISO 12100-1:2003, EN ISO 12100-2:2003 have been deleted; CEN/TS 15989, EN ISO 4413, EN ISO 7731, EN ISO 12100:2010, EN ISO 13849-1, EN ISO 13850 have been added, and EN 1846 (all parts) as well as EN 60204-1 have been updated regarding dated reference;
- jj) Bibliography revised;

kk) content of standard editorially revised.

According to the CEN-CENELEC Internal Regulations, the national standards organizations of the following countries are bound to implement this European Standard: Austria, Belgium, Bulgaria, Croatia, Cyprus, Czech Republic, Denmark, Estonia, Finland, Former Yugoslav Republic of Macedonia, France, Germany, Greece, Hungary, Iceland, Ireland, Italy, Latvia, Lithuania, Luxembourg, Malta, Netherlands, Norway, Poland, Portugal, Romania, Slovakia, Slovenia, Spain, Sweden, Switzerland, Turkey and the United Kingdom.



## **Introduction**

This European Standard is a type C standard as stated in EN ISO 12100.

The machinery concerned and the extent to which hazards, hazardous situations and events are covered are indicated in the scope of this European Standard.

When provisions of this type C standard are different from those which are stated in type A or B standards, the provisions of this type C standard take precedence over the provisions of the other standards, for machines that have been designed and built according to the provisions of this type C standard.

## 1 Scope

1.1 This European Standard specifies the safety and performance requirements and test methods applicable to turntable ladders with combined movements of classes 18, 24, 30 and > 30 to 56, as defined in 3.13, under the control of fire-fighters and intended for fire fighting and rescuing people.

NOTE This European Standard is intended to be used in conjunction with EN 1846–1, EN 1846–2 and EN 1846–3.

Turntable ladder vehicles comprise a chassis, bodywork and a powered extending structure unit in the form of a ladder with or without a rescue cage.

Turntable ladder vehicles covered by this European Standard have a self-propelled chassis, the motor of which supplies the power necessary for the operation of the ladder and permits all of the operational movements to be made simultaneously, with no restriction on the angle of the slewing movement.

1.2 This European Standard deals with the technical safety requirements to minimize the hazards listed in Clause 4 which can arise during commissioning, operational use, routine checking and maintenance of turntable ladders when carried out in accordance with the specifications given by the manufacturer or the manufacturer's authorized representative.

1.3 This European Standard deals with the use of turntable ladder vehicles within an ambient temperature range from –15 °C to +35 °C and with a wind velocity on the ladder set  $\leq 12,5$  m/s. Additional measures can be necessary for use outside this range. Special designs for use under special climatic conditions should be agreed between the manufacturer and the purchaser. Any additional requirements are outside the scope of the standard.

1.4 This European Standard does not deal with the design of a standard automotive chassis with regard to hazards resulting from or due to use as a road vehicle.

1.5 This European Standard is not applicable to turntable ladder vehicles with combined movements which are manufactured before the date of publication of this European Standard by CEN.

## 2 Normative references

The following documents, in whole or in part, are normatively referenced in this document and are indispensable for its application. For dated references, only the edition cited applies. For undated references, the latest edition of the referenced document (including any amendments) applies.

EN 1846-1, *Firefighting and rescue service vehicles - Part 1: Nomenclature and designation*

EN 1846-2:2009+A1:2013, *Firefighting and rescue service vehicles - Part 2: Common requirements - Safety and performance*

EN 1846-3, *Firefighting and rescue service vehicles - Part 3: Permanently installed equipment - Safety and performance*

CEN/TS 15989, *Firefighting vehicles and equipment - Symbols for operator controls and other displays*

EN 60204-1:2006, *Safety of machinery - Electrical equipment of machines - Part 1: General requirements (IEC 60204-1:2005, modified)*

EN 60529, *Degrees of protection provided by enclosures (IP Code) (IEC 60529)*

EN 61310-1, *Safety of machinery - Indication, marking and actuation - Part 1: Requirements for visual, acoustic and tactile signals (IEC 61310-1)*

EN ISO 4413, *Hydraulic fluid power - General rules and safety requirements for systems and their components (ISO 4413)*

EN ISO 7731, *Ergonomics - Danger signals for public and work areas - Auditory danger signals (ISO 7731)*

EN ISO 12100:2010, *Safety of machinery - General principles for design - Risk assessment and risk reduction (ISO 12100:2010)*

EN ISO 13849-1, *Safety of machinery - Safety-related parts of control systems - Part 1: General principles for design (ISO 13849-1)*

EN ISO 13850:2008, *Safety of machinery - Emergency stop - Principles for design (ISO 13850:2006)*

### 3 Terms and definitions, symbols and abbreviated terms

For the purposes of this document, the terms and definitions given in EN ISO 12100, EN 1846-1, EN 1846-2 and the following apply.

#### 3.1

##### **turntable ladder with combined movements**

machine with an extending structure in the form of a ladder set mounted on a self-propelled chassis with no restriction on the angle of the slewing movement, where the chassis engine supplies the power necessary for operation and where at least the raising/lowering, extending/retracting and the slewing right/left are simultaneously feasible under the continuous control of the operator

#### 3.2

##### **turntable ladder equipment**

entire assembly of the mobile components mounted on the chassis which can carry at its upper extent, fixed or removable rescue equipment

Note 1 to entry: The jacking system is part of the turntable ladder equipment.

#### 3.3

##### **ladder set**

part of turntable ladder comprising several ladder sections which are connected together so as to extend telescopically

#### 3.4

##### **extended ladder set length**

$L$

distance between the extreme points of the extended ladder

Note 1 to entry: The length is expressed in metres.

#### 3.5

##### **rescue cage**

fixed or removable complementary device principally used for firefighting, rescuing people and other operational services

#### 3.6

##### **angle of elevation**

$\alpha$

angle between the longitudinal axis of the last (downmost) ladder section and the horizontal

Note 1 to entry: The angle is expressed in degrees.

**3.7**  
**camber angle**

$\beta$

angle in the transverse direction to the longitudinal axis of the vehicle between the horizontal and the ground surface

Note 1 to entry: The angle is expressed in degrees.

**3.8**  
**gradient angle**

$\gamma$

angle in the longitudinal axis of the vehicle between the horizontal and the ground surface

Note 1 to entry: The angle is expressed in degrees.

**3.9**  
**slewing angle**

$\theta$

angle determined clockwise from the straight ahead position between the longitudinal axis of the vehicle and the longitudinal axis of the last ladder section projection

Note 1 to entry: The angle is expressed in degrees.

Note 2 to entry: The zero degrees position corresponds to the longitudinal axis of the vehicle facing towards the driver's cab.

**3.10**  
**rescue height**

$h$

vertical height from the horizontal ground surface to the base floor of the rescue cage without loading and in the case of turntable ladders without rescue cage the height of the topmost ladder rung

Note 1 to entry: The length is expressed in metres.

**3.11**  
**nominal rescue height**

$h_N$

specified rescue height at nominal reach

Note 1 to entry: The length is expressed in metres.

Note 2 to entry: Measured on level ground.

**3.12**  
**maximum rescue height**

$h_m$

rescue height at the maximum angle of elevation and the maximum extension distance

Note 1 to entry: The length is expressed in metres.

Note 2 to entry: Measured on level ground.

**3.13**  
**ladder's class**

identification of a turntable ladder which corresponds to the value equal or immediately less than the nominal rescue height

Note 1 to entry: The value is expressed in metres.

### 3.14 horizontal projection

$l$

distance from the outer edge of the vehicle to the perpendicular dropped from the outer edge of the base of the rescue cage or the working platform or the projection from the outer edge of the vehicle to perpendicular from the topmost rung

Note 1 to entry: The distance is expressed in metres.

Note 2 to entry: The measurement is taken at right angles to the longitudinal axis of the vehicle on horizontal terrain without loading.

Note 3 to entry: If the jacks extend beyond the maximum width of the vehicle, the distance is measured from the outer edge of the most extended jack.

### 3.15 nominal rescue projection

$l_N$

specified horizontal projection at nominal rescue height

Note 1 to entry: The projection is expressed in metres and measured in accordance with nominal rescue height (see 3.11).

### 3.16 nominal reach

$h_N / l_N$

<high rise aerial appliances> coordinates derived from nominal rescue height and nominal horizontal projection

Note 1 to entry: Values for the nominal reaches may be specified in the regulations in force in each country (see 5.2.2).

### 3.17 nominal load

$P_N$

<high rise aerial appliances> specified load with which a rescue cage or the tip of the turntable ladder may be loaded vertically within the corresponding range of free-standing use

Note 1 to entry: The load is expressed in newtons.

### 3.18 test loads

$P_P$

<high rise aerial appliances> loads applied in tests for stability, overload, and proper functioning, etc. of the turntable ladder

### 3.19 supplementary load

$P_Z$

load in addition to the nominal load, e.g. loose equipment

### 3.20 maximum working load

$P_L$

<high rise aerial appliances> greatest load with which the turntable ladder may be loaded

Note 1 to entry:  $P_L = P_N + P_Z$ .

**3.21**  
**residual force**

$F_R$   
force (at any ladder position and loading within the range of use) which is transferred to the bearing surface on the unloaded side of the vehicle during operation of the turntable ladder

Note 1 to entry: See also Figure 4.

**3.22**  
**range of use**

space within which the turntable ladder may be operated without endangering stability

**3.22.1**  
**range of free-standing use**

space in which movement at the maximum working load  $P_L$  for this range does not endanger the stability of the turntable ladder, the head of the ladder set being unsupported

**3.22.2**  
**range of supported use**

space in which the movement without loading does not endanger stability of the turntable ladder and within this space, the head of the turntable ladder set is supported, at the object, before applying the load

**3.23**  
**boundary**

<high rise aerial appliances> range of free standing boundary and supported boundary

Note 1 to entry: See Figure 1.

**3.23.1**  
**free standing boundary**

boundary in the range of free-standing use within which movement is permitted with the load  $P_L$  permitted for this range

**3.23.2**  
**supported boundary**

boundary in the range of supported use within which movement in this area is permitted, without load and with or without rescue cage

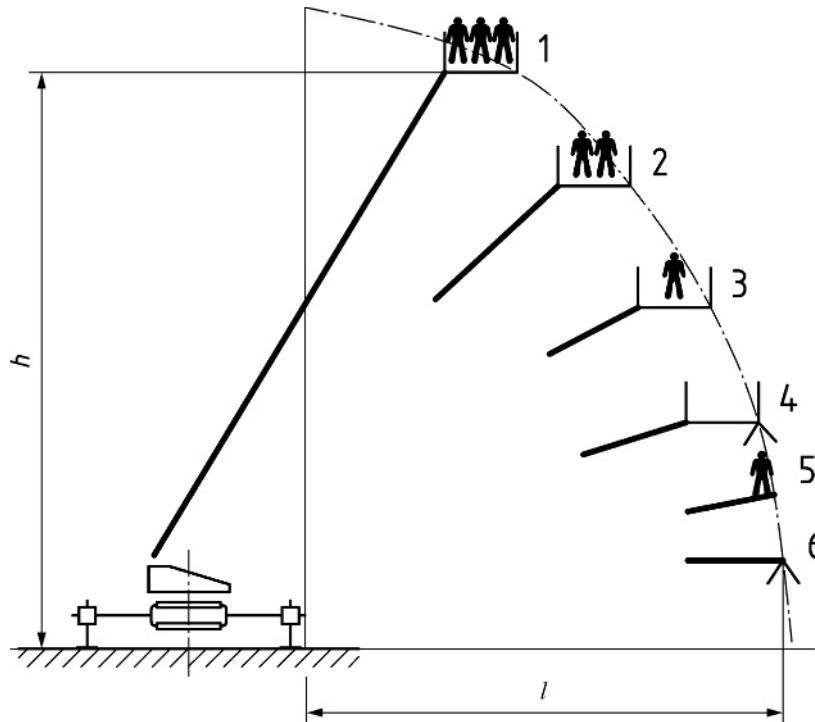

**Key**

- $l$  horizontal projection
- $h$  rescue height
- 1 to 3 free standing boundary (1 to 3 persons, with rescue cage)
- 4 supported boundary of use, with rescue cage and without load
- 5 free standing boundary with 1 person, without rescue cage
- 6 supported boundary of use, without load and without rescue cage

**Figure 1 — Example of boundary**

**3.24**

**jacking width**

$b$

distance at right angles between two imaginary parallel lines to be drawn on either side of the central axis of the vehicle at the outer edges of the furthest extended and lowered jacks including base plates

Note 1 to entry: See Figure 2.

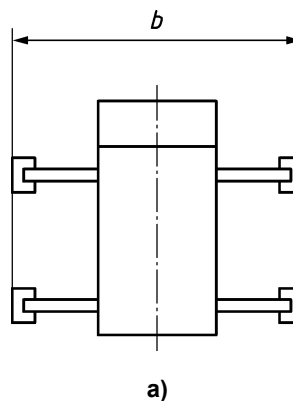

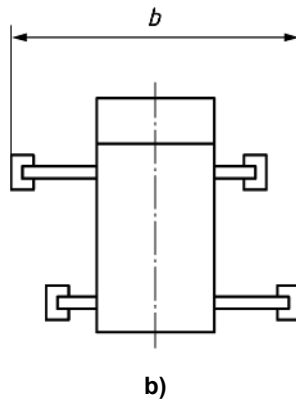

**Key**

*b* jacking width

**Figure 2 — Jacking width**

**3.25  
operating time**

$t_R$   
<high rise aerial appliances> time to reach, from the travel position, the maximum rescue height (at 90° to the longitudinal axis of the chassis)

Note 1 to entry: If appropriate the operating time  $t_R$  includes the time for attaching the rescue cage and making it ready for use with the ladder stabilized at maximum jacking width by the vehicle.

**3.26  
static stability test**

verification of a turntable ladder's ability to resist tipping or rolling over with the ladder set not being permitted to move under load

Note 1 to entry: The static stability test is not an overload test.

**3.27  
dynamic stability test**

verification of a turntable ladder's ability to resist tipping or rolling over with the ladder set being permitted to move under load

**3.28  
static overload test**

static test of the turntable ladder for permanent deformation

Note 1 to entry: The static overload test is not a stability test.

**3.29  
test of fitness for purpose**

test to confirm the correct functioning of all the functions of a turntable ladder and its special equipment

**3.30  
forces and loads for calculations**

Note 1 to entry: Forces are expressed in newtons and are measured in the direction in which they act.

Note 2 to entry: Loads are forces resulting from the mass of the components and are expressed in newtons. Their direction is the direction of the gravity.



### 3.30.1

#### static loads

<high rise aerial appliances> forces resulting from the masses which are not moved during operation of the turntable ladder

Note 1 to entry: The loads are expressed in kilograms.

### 3.30.2

#### dynamic loads

<high rise aerial appliances> forces resulting from masses which are moved during operation of the turntable ladder, including equipment moved with them, e.g. rescue cage

Note 1 to entry: The loads are expressed in kilograms.

### 3.30.3

#### load per person

load resulting from an assumed mass of 90 kg per person

### 3.30.4

#### wind loads

wind forces acting on the turntable ladder equipment and persons

Note 1 to entry: The forces are expressed in newtons.

### 3.30.5

#### diverse forces

forces exerted by persons on the rescue cage or the turntable ladder equipment and forces resulting from any particular action during ladder operation

EXAMPLE Manual forces in rescue cage or reaction forces from water jets.

Note 1 to entry: The forces are expressed in newtons.

### 3.30.6

#### dead weight load

$F_G$

forces resulting from the vehicle without ladder set

Note 1 to entry: The forces are expressed in newtons.

Note 2 to entry: See also Figure 4 and Table 2.

### 3.30.7

#### unloaded ladder load

$F_E$

forces caused by the dead weight of unloaded ladder set and a possibly attached rescue cage

Note 1 to entry: The forces are expressed in newtons.

Note 2 to entry: See also Figure 4 and Table 2.

### 3.30.8

#### inertial forces of the extended ladder

$F_n$

forces resulting from the inertia of the extended ladder

Note 1 to entry: The forces are expressed in newtons.

**3.31**  
**useful area of the rescue cage**

A

area of the floor minus the area occupied by the fixed equipment located completely or partially within the rescue cage or its perpendicular projection with the exception of the handrail and dead man's device if this is located on the floor

**3.32**  
**levelling (rungs)**

<high rise aerial appliances> movement which enables the ladder rungs to be maintained horizontally

**3.33**  
**levelling (rescue cage floor)**

<high rise aerial appliances> movement which enables the rescue cage floor to be maintained horizontally whatever may be its position on the ladder set

**3.34**  
**transport position (ladder with rescue cage)**

specific position in which the jacks are housed, the ladder set being fully housed and resting on its gantry and the power supply to the ladder set being isolated and the rescue cage in working position

Note 1 to entry: This position enables the vehicle to be moved a short distance.

**3.35**  
**travel position**

<high rise aerial appliances> same conditions as the transport position with the exception that the rescue cage is housed or stowed

**3.36**  
**ladder set sections**

ladder set comprises a first section (upper), a last section (lower) fixed to the cradle, and the intermediate sections (second section, third section, etc.) counted from the first section towards the last

Note 1 to entry: See Figure 3.

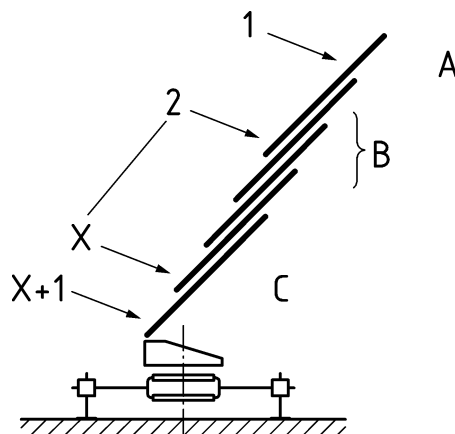

**Key**

1 to X+1	section number
A	first (upper) section
B	intermediate sections (second section, third section, etc.)
C	last (lower) section

**Figure 3 — Designation of ladder set sections**

**3.37**

**dead man's device**

<high rise aerial appliances> hold to run control device that requires continuous actuation to maintain movement

EXAMPLE Foot pedal.

**3.38**

**working position**

<high rise aerial appliances> condition of the vehicle after successful jacking and/or levelling when the rescue cage is operational and when it is possible to move/use the ladder set under normal operation

**3.39**

**stabilizing the vehicle**

stabilization procedure in the area of the under-carriage by extending and lowering of the jacking system left and right with the jacking plates firmly on the ground, according to manufacturer's instructions, and activation of the ready-to-operate signal for the upper-carriage

**3.40**

**under-carriage**

components under the slewing ring like subframe, bodywork, jacking system, chassis

**3.41**

**upper-carriage**

components above the subframe like slewing ring, turntable, main control stand and the ladder set

**4 List of significant hazards**

Table 1 describes all the significant hazards, hazardous situations and events, as far as they are dealt with in this European Standard, identified by risk assessment as significant for this type of machinery and which necessitates action to eliminate or reduce the risk.

The significant hazards are based on the principles of EN ISO 12100:2010, Annex B. Also shown are the sub-clause references to the safety requirements and/or protective measures in this document.

**Table 1 — List of significant hazards**

No.	Hazard	Assembly	Process/Function/ Cause	Clause/subclause in this European Standard/reference to applicable standards
<b>1</b>	<b>Mechanical hazards</b>			
<b>1.1</b>	<b>Crushing hazard</b>	Jacks	Moving the jacks	<ul style="list-style-type: none"> <li>• 5.1.5.2.11</li> <li>• 5.1.5.2.15</li> <li>• 5.1.5.5.2</li> <li>• Clause 7</li> </ul>
			Pressure of the jacks on the ground	<ul style="list-style-type: none"> <li>• 5.1.5.5.2</li> <li>• 5.1.5.2.12</li> <li>• 5.1.5.2.13</li> <li>• 5.1.5.2.14</li> <li>• Clause 7</li> </ul>
			Uncontrolled movement (lifting of the base plate)	<ul style="list-style-type: none"> <li>• 5.1.5.2.14</li> </ul>

No.	Hazard	Assembly	Process/Function/ Cause	Clause/subclause in this European Standard/reference to applicable standards
		Suspensions locking device	Re-establishing ground contact with the tyres during return to travel position	<ul style="list-style-type: none"> <li>• 5.1.5.2.15</li> </ul>
			Defect in the suspension locking device on activation	<ul style="list-style-type: none"> <li>• 5.1.5.2.1</li> <li>• Clause 7</li> </ul>
		Cradle/turret	Crushing by the slewing drive mechanism	<ul style="list-style-type: none"> <li>• 5.1.5.7.1</li> </ul>
			Crushing by the turret in motion	<ul style="list-style-type: none"> <li>• 5.1.5.7.1</li> <li>• 5.1.5.7.2</li> </ul>
			Crushing by the cradle in motion	<ul style="list-style-type: none"> <li>• 5.1.5.7.1</li> </ul>
		Ladder set	Crushing between the rungs during extending and housing	<ul style="list-style-type: none"> <li>• 5.1.5.5.3</li> <li>• 5.1.5.8.1</li> <li>• Clause 7</li> </ul>
		Rescue cage	Crushing by mobile parts during levelling correction	<ul style="list-style-type: none"> <li>• 5.1.5.4.8</li> </ul>
			Impact against an obstacle	<ul style="list-style-type: none"> <li>• 5.1.5.4.3</li> <li>• 5.1.5.4.12</li> <li>• 5.1.5.4.14</li> <li>• 5.1.5.5.3</li> <li>• 5.1.5.5.5</li> <li>• 5.1.5.8.4</li> <li>• Clause 7</li> </ul>
			Fitting/removal of the rescue cage	<ul style="list-style-type: none"> <li>• 5.1.5.4.6</li> </ul>
			Movement in the rescue cage	<ul style="list-style-type: none"> <li>• 5.1.5.4.13</li> </ul>
			Crushing a person outside the rescue cage	<ul style="list-style-type: none"> <li>• 5.1.5.4.12</li> <li>• 5.1.5.5.3</li> <li>• 5.1.5.5.4</li> <li>• 5.1.5.8.1</li> <li>• Clause 7</li> </ul>
		1.2	Shearing hazard	Cradle/turret
Ladder set	Crushing between the rungs during extending and housing			<ul style="list-style-type: none"> <li>• 5.1.5.5.3</li> <li>• 5.1.5.8.1</li> </ul>
Rescue cage	Crushing by mobile parts during levelling correction			<ul style="list-style-type: none"> <li>• 5.1.5.4.8</li> </ul>

No.	Hazard	Assembly	Process/Function/ Cause	Clause/subclause in this European Standard/reference to applicable standards
			Impact against an obstacle	<ul style="list-style-type: none"> <li>• 5.1.5.4.12</li> <li>• 5.1.5.5.3</li> <li>• 5.1.5.5.5</li> </ul>
1.3	Cutting or severing hazard	General		• EN 1846–2
		Ladder set	Damaged wire ropes	• 5.1.5.8.2
1.4	Entanglement hazard	General	All moving parts	<ul style="list-style-type: none"> <li>• 5.1.5.7.1</li> <li>• 5.1.5.8.2</li> <li>• Clause 7</li> </ul>
		Jacks	Movement of the jacks	<ul style="list-style-type: none"> <li>• 5.1.5.2.11</li> <li>• 5.1.5.2.14</li> <li>• 5.1.5.2.15</li> <li>• 5.1.5.5.2</li> <li>• Clause 7</li> </ul>
		Cradle/turret	Entanglement by pinion/crown	• 5.1.5.7.2
			Entanglement by the moving turret	<ul style="list-style-type: none"> <li>• 5.1.5.5.3</li> <li>• 5.1.5.7.1</li> <li>• 5.1.5.7.2</li> </ul>
		Rescue cage	Rescue cage deployment control	• 5.1.5.5.4
		Ladder set	Entanglement by pulley and chains and entanglement by the winding drum	• 5.1.5.8.2
1.5	Drawing-in or trapping hazard	General	Presence of a person in the working area	• 5.1.5.5.6
1.6	Impact hazard	Jacks	Movement of the jacks	<ul style="list-style-type: none"> <li>• 5.1.5.5.2</li> <li>• 5.1.5.2.14</li> <li>• Clause 7</li> </ul>
			Put pressure on the ground	<ul style="list-style-type: none"> <li>• 5.1.5.5.2</li> <li>• 5.1.5.2.14</li> <li>• Clause 7</li> </ul>
		Neutralization suspension	Re-establishing ground contact with the tyres during return to travel position	• 5.1.5.2.15
		Cradle/turret	Crushing by the turret in motion	<ul style="list-style-type: none"> <li>• 5.1.5.5.3</li> <li>• 5.1.5.7.1</li> <li>• 5.1.5.7.2</li> <li>• Clause 7</li> </ul>

No.	Hazard	Assembly	Process/Function/ Cause	Clause/subclause in this European Standard/reference to applicable standards	
		Rescue cage	Impact against an obstacle	<ul style="list-style-type: none"> <li>• 5.1.5.4.3</li> <li>• 5.1.5.4.12</li> <li>• 5.1.5.4.14</li> <li>• 5.1.5.5.3</li> <li>• 5.1.5.5.5</li> <li>• 5.1.5.8.4</li> <li>• Clause 7</li> </ul>	
1.8	Friction or abrasion hazard	General	Moving parts	• 5.1.5.7.3	
			Couplings, etc.	• 5.1.5.9	
			<ul style="list-style-type: none"> <li>• Wire ropes</li> <li>• Linkages</li> <li>• All hydraulic components</li> </ul>	• Clause 7	
1.9	High pressure fluid injection or ejection hazard	Hydraulic systems	drive	Injury and/or contamination by leakage or rupture	<ul style="list-style-type: none"> <li>• 5.1.5.9</li> <li>• Clause 7</li> </ul>
<b>2</b>	<b>Electrical hazards</b>				
2.1	Contact of persons with live parts (direct contact)	Overall design	General measures	• EN 60204-1	
2.2	Contact of persons with parts which have become live under faulty conditions (indirect contact)	Overall design	General measures	• EN 60204-1	
2.3	Approach to live parts under high voltage	Ladder set	Contact with overhead electrical conductors	<ul style="list-style-type: none"> <li>• 5.1.5.2.10</li> <li>• Clause 7</li> </ul>	
2.4	Electrostatic hazard	General		• 5.1.5.2.10	
<b>4</b>	<b>Hazard generated by noise</b>				
4.1	Interference with speech communication, acoustic signals, hearing loss, tinnitus, etc.	Communications		• 5.1.5.8.4	
		Ladder	Normal operation	<ul style="list-style-type: none"> <li>• 5.1.5.8.4</li> <li>• 5.1.6</li> <li>• EN 1846-2:2009+A1: 2013, Annexes E and F</li> </ul>	
<b>6</b>	<b>Hazards generated by radiation</b>				
6.1	Low frequency, radio frequency radiation, micro waves	General	Normal operation	• 5.1.5.16	

No.	Hazard	Assembly	Process/Function/ Cause	Clause/subclause in this European Standard/reference to applicable standards
8	<b>Hazards generated by neglecting ergonomic principles in turntable ladder with combined movement design</b>			
8.1	<b>Unhealthy postures or excessive effort</b>	Ladder set	Rescue <ul style="list-style-type: none"> <li>• access ladder/chassis deck</li> <li>• access ladder/ground level</li> <li>• Emergency operating system</li> </ul>	<ul style="list-style-type: none"> <li>• 5.1.5.8.3</li> <li>• 5.1.5.11.2</li> <li>• 5.1.2.3.4</li> </ul>
		Rescue cage	Fitting/removal	<ul style="list-style-type: none"> <li>• 5.1.5.4.6</li> </ul>
8.2	<b>Inadequate consideration of hand-arm or foot-leg anatomy</b>	Jack control console	Jack control	<ul style="list-style-type: none"> <li>• 5.1.5.5.1</li> <li>• 5.1.5.5.2</li> </ul>
		Cradle/turret control console	Cradle/turret movement control	<ul style="list-style-type: none"> <li>• 5.1.5.5.1</li> <li>• 5.1.5.5.3</li> </ul>
		Ladder set control console	Ladder set movement control	<ul style="list-style-type: none"> <li>• 5.1.5.5.1</li> <li>• 5.1.5.5.3</li> </ul>
		Ladder set	Access	<ul style="list-style-type: none"> <li>• 5.1.5.11.2</li> <li>• 5.1.5.11.5</li> </ul>
		Rescue cage control console	Ladder/cradle/turret movement	<ul style="list-style-type: none"> <li>• 5.1.5.5.1</li> <li>• 5.1.5.5.5</li> </ul>
			Good visibility of the movement	<ul style="list-style-type: none"> <li>• 5.1.5.5.5</li> </ul>
		Main control console	Access	<ul style="list-style-type: none"> <li>• 5.1.5.5.3</li> </ul>
8.3	<b>Neglected use of personal protection equipment</b>	General		<ul style="list-style-type: none"> <li>• Clause 7</li> </ul>
8.4	<b>Inadequate local lighting</b>	Control consoles	Use of consoles	<ul style="list-style-type: none"> <li>• 5.1.5.5.1</li> </ul>
		Access to the main control console	Use of consoles	<ul style="list-style-type: none"> <li>• 5.1.5.5.3</li> </ul>
8.5	<b>Mental overload and underload, stress</b>	All movements	Use of controls without error	<ul style="list-style-type: none"> <li>• 5.1.5.5.1</li> <li>• 5.1.5.5.2</li> <li>• 5.1.5.5.3</li> <li>• 5.1.5.5.5</li> </ul>
8.6	<b>Human error, human behaviour</b>	Control consoles	Operating controls/reading information of	<ul style="list-style-type: none"> <li>• 5.1.5.5</li> <li>• Clause 7</li> </ul>
10	<b>Unexpected start-up, unexpected overrun/overspeed (or any similar malfunction)</b>			
		The whole ladder	General operation	<ul style="list-style-type: none"> <li>• 5.1.5</li> </ul>
			Intentional stop or failure of the main power supply	<ul style="list-style-type: none"> <li>• 5.1.2.3.4</li> <li>• 5.1.2.3.5</li> </ul>

No.	Hazard	Assembly	Process/Function/ Cause	Clause/subclause in this European Standard/reference to applicable standards
10.3	External influences on electrical equipment	Electrical circuits and components	General measures	• 5.1.5.10
10.5	Errors in the software	Software		• 5.1.5.12
13	<b>Failure of the power supply</b>			
		The whole ladder	General operation	• 5.1.2.3.4
			Intentional stop or failure of the main power supply	• 5.1.2.3.4
		Jacks	Rupture of the power supply of the components	• 5.1.5.2.5
		Suspension locking	Rupture of the power supply of the components	• 5.1.5.2.5
		Cradle/turret	Failure of the power supply of the components	• 5.1.5.13.1
		Ladder set	Rupture of the power supply of the components	• 5.1.5.13.1
		Rescue cage	Rupture of the power supply of the components	• 5.1.5.13.1
		Software	Insufficient supply and/or failure	• 5.1.5.12.3 • 5.1.5.12.8
14	<b>Failure of the control circuit</b>			
		Jacks	Failure in the control software	• 5.1.5.12
			Restarting	• 5.1.5.5.1
		Suspension locking	Failure in the control software	• 5.1.5.12
			Restarting	• 5.1.5.5.1
		Cradle/turret	Failure in the control software	• 5.1.5.12
			Restarting	• 5.1.5.5.1
			Failure of a drive or load retaining element	• 5.1.5.13.1 • 5.1.5.13.2 • 5.1.5.13.3
		Ladder set	Failure in the control software	• 5.1.5.12
			Restarting	• 5.1.5.5.1
			Failure of a drive or load retaining element	• 5.1.2 • 5.1.5.13.1 • 5.1.5.13.2 • 5.1.5.13.3
		Rescue cage	Failure in the control software	• 5.1.5.12



No.	Hazard	Assembly	Process/Function/ Cause	Clause/subclause in this European Standard/reference to applicable standards
			Restarting	• 5.1.5.5.1
			Failure of a drive or load retaining element	• 5.1.5.4.1 • 5.1.5.4.7 • 5.1.5.5.1
		Analogue detectors	Normal operation	• 5.1.5.12.6 • 5.1.5.12.7
		Logical detectors	Normal operation	• 5.1.5.12.3 • 5.1.5.12.5 • 5.1.5.12.7 • Clause 7
		Management of the stability	Normal operation	• 5.1.2.3
			Operation without safety measures	• 5.1.2.3.5
<b>15</b>	<b>Errors of fitting</b>			
		Rescue cage	Fitting of the rescue cage to the tip of the ladder set	• 5.1.5.4.6 • 5.1.5.4.7
<b>17</b>	<b>Falling or ejected objects or fluids</b>			
		General		• 5.1.5.9 • Clause 7
		Drive systems hydraulic	Injury and/or contamination by leakage or rupture	• 5.1.5.9 • Clause 7
		Rescue cage	Elements falling from the rescue cage	• 5.1.5.4.3 • 5.1.5.4.5 • 5.1.5.4.11
<b>18</b>	<b>Loss of stability/overturning of vehicle</b>			
		General	All movements	• 5.1.1 • 5.1.2 • 5.1.5.2.17
		Jacks	Unsuitable ground	• 5.1.5.2.12 • Clause 7
			Movement of the vehicle	• 5.1.5.1
			Variation of jacking width	• 5.1.5.2
			Unevenness of the ground	• 5.1.5.2.6 • 5.1.5.2.7 • 5.1.5.2.8
		Jacking	Ground pressure failure	• 5.1.5.2.2 • 5.1.5.5.3 • Clause 7

No.	Hazard	Assembly	Process/Function/ Cause	Clause/subclause in this European Standard/reference to applicable standards	
			Technical defect	• 5.1.1	
			Inadvertent operation	• 5.1.5.2.4	
			Damage to the jacks due to external action	• 5.1.5.2.11	
		Suspension locking		Normal operation	• 5.1.5.2.16
		Cradle/turret		Technical defect	• 5.1.1
				Exterior impact	• 5.1.5.7.2
		Ladder set		Exceeding the stability limits	• 5.1.2 • 5.1.5.3.3 • 5.1.5.3.4
				Overload	• 5.1.3
				External influence by wind load	• 5.1.5.6 • Clause 7
				Exceeding the limits of free standing use in order to attain the limits of supported use	• 5.1.2.3.2 • Clause 7
		Rescue cage		Overload in the rescue cage	• 5.1.5.4.13 • Clause 7
		<b>19</b>	<b>Slip, trip and fall of persons (related to machinery)</b>		
		Vehicle deck	Standing or moving	• 5.1.5.11.1 • 5.1.5.11.3	
		Ladder set	Rungs	• 5.1.5.3.1 • 5.1.5.8.5 • 5.1.5.11.4	
		Rescue cage	Defective horizontal alignment of the rescue cage floor	• 5.1.5.4.2 • Clause 7	
			Access rescue cage / ladder	• 5.1.5.4.9	
<b>21</b>	<b>Hazards linked to the work position</b>				
<b>21.1</b>	<b>Fall of persons during access to (or at/from) the work position</b>	Vehicle deck	Getting up and down	• 5.1.5.11.2 • 5.1.5.11.5 • 5.1.5.11.6	
			Standing or moving on the platform surface	• 5.1.5.11.1 • 5.1.5.11.3	
		Cradle/turret	Access to main control console if required	• 5.1.5.5.3	

No.	Hazard	Assembly	Process/Function/ Cause	Clause/subclause in this European Standard/reference to applicable standards
		Ladder set	Access	<ul style="list-style-type: none"> <li>• 5.1.5.8.3</li> <li>• Clause 7</li> </ul>
		Rescue cage	Access to rescue cage/ ladder	<ul style="list-style-type: none"> <li>• 5.1.5.4.9</li> </ul>
<b>21.8</b>	<b>Noise at the work position</b>	Ladder	Normal operation	<ul style="list-style-type: none"> <li>• EN 1846-2</li> </ul>
<b>35</b>	<b>Falling of person from person carrier</b>			
		Rescue cage	Falling from the rescue cage	<ul style="list-style-type: none"> <li>• 5.1.5.4.3</li> <li>• 5.1.5.4.4</li> <li>• Clause 7</li> </ul>
<b>37</b>	<b>Human error, human behaviour</b>			
		Control consoles	Operating controls	<ul style="list-style-type: none"> <li>• 5.1.5.3</li> <li>• 5.1.5.5</li> <li>• Clause 7</li> </ul>
			Reading of information	<ul style="list-style-type: none"> <li>• 5.1.5.5</li> <li>• Clause 7</li> </ul>

## 5 Requirements

### 5.1 Safety requirements and/or measures

#### 5.1.1 General

Turntable ladders for fire and rescue service use shall comply with the safety requirements and/or protective measures of this clause. In addition, they shall be designed according to the principles of EN ISO 12100 for hazards relevant but not significant, which are not dealt with by this European Standard (e.g. sharp edges).

For hazards which are to be reduced by the application of EN ISO 12100 and a B-level standard such as EN 60204-1, EN ISO 4413, EN ISO 7731, EN ISO 13849-1 and EN ISO 13850, the manufacturer should carry out a risk assessment to establish the requirements of the B-standard which are to be applied. This specific risk assessment should be part of the general risk assessment of the turntable ladder.

Where the means of reducing the risk is by a safe system of operating the turntable ladder, the instruction handbook shall include details of the system and of the elements of training necessary for the operating personnel.

Proven methods of calculation shall be used, including consideration for fatigue, which have been verified by analysis or test.

Turntable ladders shall comply with the relevant clauses of EN 1846-2 and EN 1846-3.

Unless otherwise specified, for the performance of the tests, the mass of the vehicle shall be the unladen mass.

## **5.1.2 Requirements in respect of stability**

### **5.1.2.1 Theoretical requirements: Calculation**

#### **5.1.2.1.1 General**

The manufacturer shall define the various positions of the turntable ladder and the combinations of loads and forces which together represent the conditions for minimum stability.

Calculations shall be carried out for establishing that in all positions of the turntable ladder the calculated stabilizing moment will be greater than the calculated tipping moment taking into account the safety factors in accordance with 5.1.2.1.5 (see Table 2).

Forces shall be calculated for the least favourable extended and/or housed positions of the turntable ladder with respect to the maximum camber the turntable ladder vehicle is intended for.

The rules for the determination of the forces and loads are described in 5.1.2.1.2 to 5.1.2.1.5.

All loads and forces which may act simultaneously shall be calculated in their least favourable combination (see example in Figure 4).

The following shall be included in the calculation:

- a) pitching inaccuracies as specified in 5.1.2.1.5.8 (see Table 2);
- b) variations resulting from manufacturing inaccuracies in the components;
- c) tolerances for the mechanical linkages in the ladder set;
- d) elastic deformation resulting from applied forces.

Enumeration points b), c) and d) may be determined by experiment.

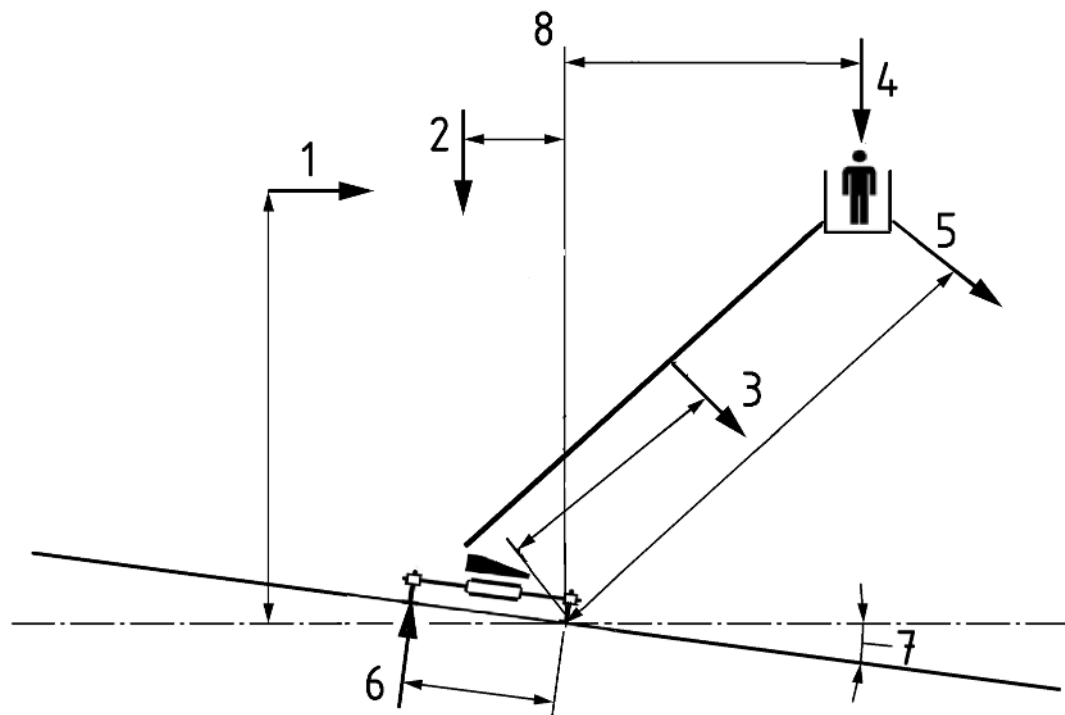

**Key**

- 1 force resulting from wind load,  $F_w$
- 2 force resulting from dead weight load,  $F_G$  and  $F_E$
- 3 force resulting from inertial forces tangential to direction of movement,  $F_N$
- 4 force resulting from the working load,  $F_L$
- 5 force resulting from diverse forces (e.g. manual force, water weight, jet reaction),  $F_s$
- 6 force resulting from residual forces,  $F_R$
- 7 angle being the combination of camber angle and gradient angle
- 8 tipping line

**Figure 4 — Example of forces acting on turntable ladder**

**5.1.2.1.2 Calculation of the working load**

The working load shall be taken to act as a point load on the platform at a horizontal distance of 0,1 m from the inside edge of the hand rail and in the centre line of the ladder at 1 m height above the cage floor (see Figure 5).

For ladders without rescue cage, the mass shall be applied at the end of the ladder set, in the centre of the last rung.

The mass corresponding to the supplementary load shall be at least 25 kg.

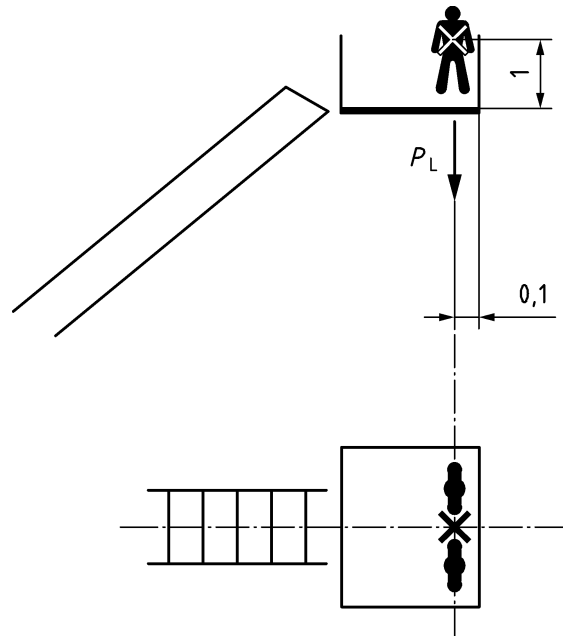

**Key**

$P_L$  point of application of the working load

**Figure 5 — Resulting force of the working load**

**5.1.2.1.3 Calculation of wind loads**

**5.1.2.1.3.1** Turntable ladder vehicles used in the open air shall be considered as being subjected to wind with a static pressure of  $100 \text{ N/m}^2$  which corresponds to a wind velocity of  $12,5 \text{ m/s}$  (6 on the Beaufort scale).

Wind forces shall be calculated by assuming that the wind is horizontal and acts on the surfaces of components exposed to the wind and to be dynamic forces acting at their centres of area.

**5.1.2.1.3.2** Wind forces shall be calculated using the following formula:

$$F_w = q \times A_{proj.} \tag{1}$$

where

- $q$  is the impact pressure of  $100 \text{ N/m}^2$  and
- $A_{proj.}$  is the outside surface of the ladder exposed to the wind.

**NOTE** If additional information is needed, especially concerning shielded structural areas, see ISO 4302.

**5.1.2.1.3.3** The area of an occupied rescue cage exposed directly to the wind shall be calculated by multiplying the width of the side of the rescue cage exposed to the wind, rounded up to the nearest  $0,5 \text{ m}$ , by the overall height of the rescue cage plus  $0,4 \text{ m}$  (see Figure 6).

**EXAMPLE** If the width of the rescue cage exposed to the wind is  $1,25 \text{ m}$  and the overall height of the rescue cage is  $1,15 \text{ m}$ , the area exposed to the wind is  $1,5 \text{ m} \times (1,15 \text{ m} + 0,4 \text{ m}) = 2,325 \text{ m}^2$ .

Dimensions in metres

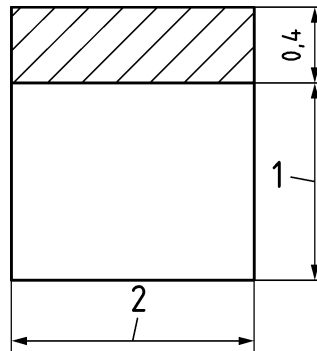

**Key**

- 1 overall height of rescue cage
- 2 width exposed to the wind

**Figure 6 — Surface exposed to the wind**

**5.1.2.1.3.4** The wind force acting on the equipment in the rescue cage shall be calculated as a force equal to 3 % of dead weight (see Table 2) of the equipment acting at a point 0,5 m above the base of the rescue cage.

**5.1.2.1.4 Calculation of diverse force**

A minimum value for the diverse force of 200 N with one person and 400 N or more with more persons shall be applied for turntable ladder vehicles. The diverse force shall be taken to act at a height of 1,1 m above the base of the rescue cage. Any greater force shall be specified by the manufacturer.

**5.1.2.1.5 Safety factors for turntable ladders**

**5.1.2.1.5.1** Table 2, Figure 4 and Figure 5 shall be used for the load calculations.

**Table 2 — Safety factors for load calculations**

	Symbol	Unit	Direction of action	Factors for use in calculations	
				≤ 0,7 m/s	> 0,7 m/s
Speed of movement	$V$	m/s	-	≤ 0,7 m/s	> 0,7 m/s
Forces resulting from gravity (dead weight)	$F_G$ and $F_E$	N	vertical	$1,0 \times F_G$ $1,0 \times F_E$	
Force resulting from working load (applied load)	$F_L$	N	vertical	$1,25 \times F_L$	
Inertial forces	$F_N$	N	tangential to direction of movement	$0,1 \times F_E$ + $0,1 \times F_L$	$0,2 \times F_E$ + $0,2 \times F_L$
Wind forces	$F_W$	N	horizontal	$1,1 \times F_W$	
Diverse forces	$F_S$	N	Selected angle	$1,1 \times F_S$	

<b>Key</b>	
$F_L = P_L \times g$ (N)	$F_G = m_G \times g$ (N)
$F_E$ is the force resulting from the dead weight of the unloaded ladder set and a possibly attached rescue cage (N) = $m_E \times g$	$g = 9,81$ (m/s <sup>2</sup> )
$m_E$ is the mass of the ladder set (kg)	$m_G$ is the mass (kg)
NOTE	Pitching inaccuracies (sloping ground): 0,5° (see 5.1.2.1.5.8).

**5.1.2.1.5.2** Forces resulting from gravity ( $F_G$  and  $F_E$ ) which generate a tipping moment and/or righting moment, shall be multiplied by the factor of 1,0. They are assumed to be acting vertically downwards.

**5.1.2.1.5.3** Forces resulting from the gravity of the maximum working load ( $F_L$ ), which create a tipping moment and/or righting moment shall be multiplied by the factor of 1,25. They are assumed to be acting vertically downwards.

**5.1.2.1.5.4** Inertial forces resulting from masses in motion (mass forces  $F_N$ ) shall be multiplied by a factor of 0,1 for  $V \leq 0,7$  m/s and by the factor of 0,2 for  $V > 0,7$  m/s. They are assumed to act tangentially to the direction of movement which generates the maximum tipping moment and applied to the centre of gravity of the structure in motion.

**5.1.2.1.5.5** Diverse forces ( $F_S$ ) (e.g. manual forces, reaction to a water jet) shall be multiplied by the factor of 1,1 and assumed to act in the direction of movement which generates the maximum tipping moment.

**5.1.2.1.5.6** Wind forces ( $F_W$ ) having an influence on stability shall be multiplied by the factor of 1,1. They are assumed to act horizontally.

**5.1.2.1.5.7** The absolute velocity at the head of the extended ladder set under normal working conditions shall be taken as the speed of movement  $V$ .

**5.1.2.1.5.8** Forces resulting from 0,5° pitching inaccuracies in turntable ladders shall also be included in calculations (see Table 2 and 5.1.2.1.1).

#### **5.1.2.1.6 Fatigue stress analysis**

Fatigue strength calculations shall be carried out to avoid the risk of fractures by the formation and propagation of cracks in critical components or connections under cyclic load.

Lifetime calculations shall be based on the following number of load cycles:

— 58 500 load cycles (calculation based on 15 years × 52 weeks × 15 h × 5 cycles).

The proof shall be performed for all structural components and connections that are critical in terms of fatigue. All welded connections are to be regarded as critical if they are subjected to cyclic loading. This can be achieved:

- by calculation in accordance with EN 13001-3-1:2012+A1:2013, Clause 6 (proof of fatigue strength) or
- by a simplified method for rated stress. For this, the operating loads that occur shall be determined and resulting rated stresses shall be below permissible limit stresses. These limit stresses shall be based on yield strength taking into account safety factors suitable for material used and the influence of weld seam in the considered zone.

NOTE 1 Experience has shown that the simplified method given in b) is sufficient for the design of turntable ladders primarily because of the relatively small number of load cycles.

NOTE 2 Because of the variation in design and materials used it is not possible in this standard to define limit stresses. The manufacturer is responsible for using appropriate limit stresses.



### 5.1.2.2 Validation of stability calculations

#### 5.1.2.2.1 Static stability

With symmetrically positioned jacks, static stability shall be demonstrated by measuring the minimum residual force ( $F_{Rmin}$ ). Depending on the jacking width (see Figure 8)  $F_{Rmin}$ , expressed as the percentage of the corresponding unladen mass according to EN 1846-2 without driver, shall be greater than or equal to the residual force indicated in Figure 7, in all permissible ladder positions including in the least favourable positions.

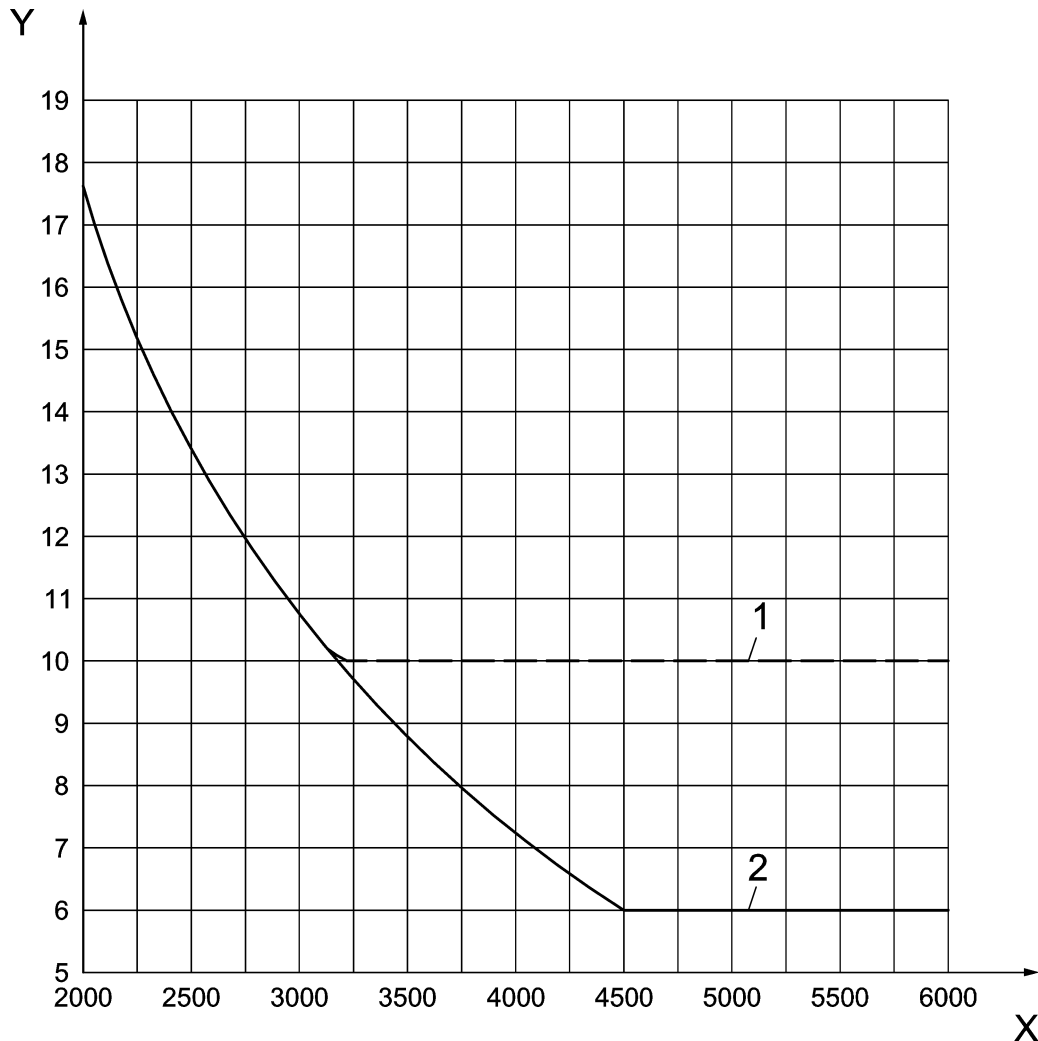

#### Key

- X jacking width in millimetres
- Y residual force in % of unladen mass according to EN 1846-2 without driver
- 1 residual force when front and/or rear tyres are on the weighing device
- 2 residual force when front and rear tyres are not on the weighing device

**Figure 7 — Minimum required residual force related to jacking width**

The specified supplementary load  $P_z$ , shall be simulated if not available and included in each stability test. Static stability shall be demonstrated with the following test load in all required ladder positions:

$$P_p = 1,1 \times P_N + P_z \quad (2)$$

where

$P_z = 0$  for vehicles without a rescue cage, unless the design incorporates the application of a load.

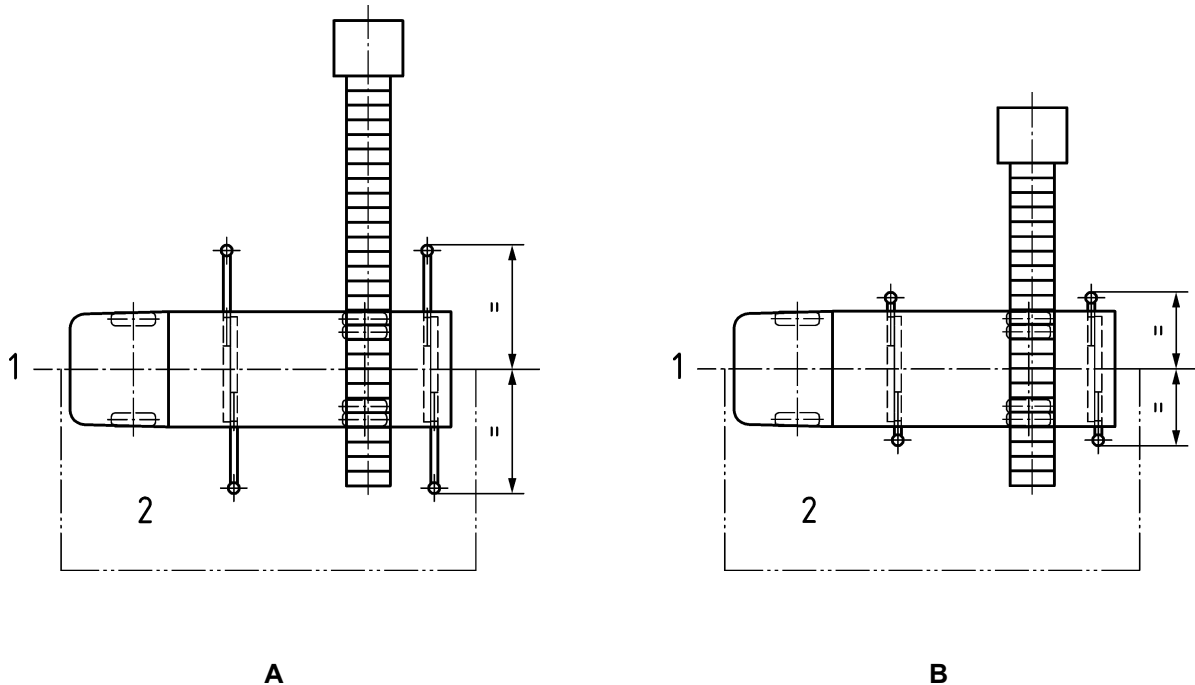

**Key**

- A maximum jacking width
- B minimum jacking width
- 1 middle axis of vehicle
- 2 weighing device

**Figure 8 — Maximum and minimum jacking width**

**Verification:**

The unladen mass of the turntable ladder without a driver shall be measured.

The minimum and - if different - maximum jacking width shall be measured. The jacking width shall be measured over the outer edges of the baseplates of the jacks.

The supporting wheels and vertical jacks of the vehicle located at the side of the longitudinal central axis of the vehicle, where the residual vertical force will be reduced during the application of the test load, shall be supported by the load weighing device, as indicated at Figure 8 A and Figure 8 B as appropriate. The minimum residual force  $F_{Rmin}$  applied by the wheels and jacks to the supporting surface shall be the load indicated by the weighing device. The test shall be carried out on a hard flat horizontal surface ( $0 \pm 0,5$ )°.

The test load specified in 5.1.2.2.1 shall be applied as follows:

- in the case of turntable ladders without a rescue cage, the test load is applied to the last rung of the ladder (see Figure 9);
- in the case of turntable ladders with a rescue cage, the test load is applied at a distance of 0,1 m from the inside edge of the hand rail and the centre line of the ladder set (see Figure 10).

Position the ladder to the side of the longitudinal axis of the vehicle, as indicated at Figure 8, and move into a ladder elevation angle of  $(0 \pm 2)^\circ$  before extending the ladder to the boundary of use corresponding to the conditions of the test.

For each test the minimum residual force  $F_{Rmin}$  shall comply with the requirements of Figure 7.

As a minimum, tests shall be carried out at minimum and maximum jacking width. Table A.1 indicates the tests required and the method for recording the results. The static stability tests shall include the least favourable permitted position of the ladder, load and jacks.

An example of a table to report the results of the stability test is given at Annex A (see Table A.1)

#### 5.1.2.2.2 Dynamic stability

The minimum residual force  $F_{Rmin}$  shall be greater than 0 in the least favourable position of the turntable ladder when standing on a hard flat horizontal surface  $(0 \pm 0,5)^\circ$ .

##### Verification

Verification methods 1 and 2 shall be carried out as part of the type test. Verification method 1 is also relevant to fitness for purpose testing/use (reception test) – see Table D1.

##### Verification method 1:

Demonstrate the dynamic stability with the following test load:

$$P_p = 1,25 \times P_N + P_Z \quad (3)$$

The supporting wheels and vertical jacks of the vehicle located on the side of the longitudinal central axis of the vehicle where the residual vertical force will be reduced during the application of the test load and dynamic forces shall be supported by the load weighing device, as indicated at Figure 8 A and Figure 8 B as appropriate. The minimum residual force  $F_{Rmin}$  applied by the wheels and jacks to the supporting surface shall be the load indicated by the weighing device. The test shall be carried out on a hard flat horizontal surface  $(0 \pm 0,5)^\circ$ .

During the course of the dynamic tests, carry out the movements at maximum permissible ladder speed under normal operating conditions, the movements being stopped using the emergency stop or the dead man's device.

For the purposes of the dynamic tests, position the ladder in such a way that the slewing angle  $\theta$ , the jacking width and the load correspond to the least favourable position identified during the course of the test described in 5.1.2.2.1. The slewing angle shall be within  $\pm 1^\circ$  of the required value.

For the purpose of the dynamic test for lowering, position the ladder to the maximum possible elevation angle  $\alpha$ , and then operate the lowering control device. Check the minimum residual force during movement and for 10 s after movement is ceased.

For the purposes of the dynamic test for raising, set the ladder in such a way that the projection and height correspond to the maximum permissible projection and height for slewing angle  $\theta$ , jacking width and load corresponding to the least favourable position identified during the course of the test described in 5.1.2.2.1. The slewing angle shall be within  $\pm 1^\circ$  of the required value. Then operate the raising control device. Record the minimum residual force for 10 s before the movement commenced and during the movement.

An example of table to report the result of the stability test is given in Annex A (see Table A.1).

Verification method 2:

For the purpose of the tests - if necessary - secure the turntable ladder vehicle against overturning at two anchoring points without affecting the validity of the tests, position the ladder in such a way that the slewing angle  $\theta$ , the jacking width and the load correspond to the least favourable position identified during the course of the test described in 5.1.2.2.1. The slewing angle shall be within  $\pm 1^\circ$  of the required value.

Measure the minimum residual force  $F_{Rmin}$  according to 5.1.2.2.1.

The supporting wheels and vertical jacks of the vehicle located on the side of the longitudinal central axis of the vehicle, where the residual vertical force will be reduced during the application of the test load, shall be supported by the load weighing device, as indicated at Figure 8 A and Figure 8 B, as appropriate. The minimum residual force  $F_{Rmin}$  applied by the wheels and jacks to the supporting surface shall be the load indicated by the weighing device. The test shall be carried out on a hard flat horizontal surface ( $0 \pm 0,5$ )°.

Position blocks 180 mm in height under the wheels on the weighing device and - if necessary - under the baseplates of the jacks.

Test procedure:

- load the ladder set with the test load  $P_p = 1,1 \times P_N + P_Z$ ;
- raise the ladder set up to an angle of  $+15^\circ$  from the horizontal;
- slew the ladder set to a position at  $90^\circ$  to the longitudinal axis of the vehicle as indicated at Figure 8;
- extend the ladder set to a position 1 m before the maximum permitted extension;
- lower the ladder set by an angle of  $10^\circ$  at maximum speed and conduct an immediate and sudden stop of the movement using the emergency stop or the dead man's device;
- check whether the residual force is greater than 0 during the 10 s immediately following the cessation of movement.

Carry out this test for the cases defined in Table 3.

**Table 3 — Test cases for verification method 2**

Movement	Elevation angle at the beginning of the movement	Elevation angle when activating the emergency stop
lowering	+20°	+10°
	+15°	+5°
	+10°	0°
elevation	-15° <sup>a</sup>	-5°
	-10° <sup>a</sup>	0°
	-5°	+5°

<sup>a</sup> If possible for the chosen load. If not possible for the chosen load, use the weakest possible elevation angle.

### 5.1.2.3 Functional requirements

**5.1.2.3.1** Automatically operating limit switches shall be provided for every movement, with the exception of slewing. See also 5.1.5.5.

Verification:

*Design check and functional tests.*

**5.1.2.3.2** Devices shall be provided for stopping movements automatically and smoothly, and producing an optical warning at the control consoles, when the free-standing boundary is reached. For emergency rescue situations, the machine shall be designed to move the ladder at reduced speed with the normal control devices beyond the free-standing boundary until the overload limit is reached.

Verification:

*Where the jacking width is variable, the tests shall be carried out at the jacking widths corresponding to the minimum and maximum boundaries of use.*

*Place the ladder vehicle on a hard and essentially horizontal surface.*

*Load the cage/ladder with a load equivalent to the permissible number of persons.*

*Position the ladder so that the elevation angle  $\alpha$  is  $(0 \pm 3)^\circ$ .*

*Note the maximum projection at the beginning of the test in the report.*

*Extend the ladder to the automatic stop at the boundary of free-standing use.*

*The actual projection displayed shall be equal to the maximum projection authorized at the beginning of the test with an accuracy of  $\pm 4\%$  of the measuring range.*

*Raise the ladder to the maximum angle.*

*Extend the ladder to the maximum length.*

*Lower the ladder to the automatic stop at the boundary of free-standing use.*

*Check that the actual projection displayed is equal to the maximum projection at the beginning of the test with an accuracy of  $\pm 4\%$  of the measuring range.*

**5.1.2.3.3** A stability monitoring device shall be provided. This device shall detect the resultant overturning moment acting on the ladder due to the effect of the mass of the ladder and all other loads applied to it. Additionally the device shall warn both optically and audibly when reaching a boundary as defined in 3.23, while movements other than those which reduce tilting moment shall be prevented. See also 5.1.5.5.

Verification:

*Position the ladder with jacks down (see Figure 9 and Figure 10).*

*Load the ladder with a load equivalent to permissible number of persons.*

*Position the turntable ladder in such a way so that the angle of rotation is equal to  $(90 \pm 3)^\circ$ . Extend the ladder raised to any elevation angle  $\alpha$  to the automatic stop at the boundary of free-standing use.*

Increase the overturning moment by means of a device which permits gradual application of a continuous load whilst rendering the dynamic effects negligible (for example: hauled rope) until the optical and audible warning devices are triggered in the danger zone.

Check that the residual force measured is equal to or greater than the minimum residual force according to 5.1.2.2.1.

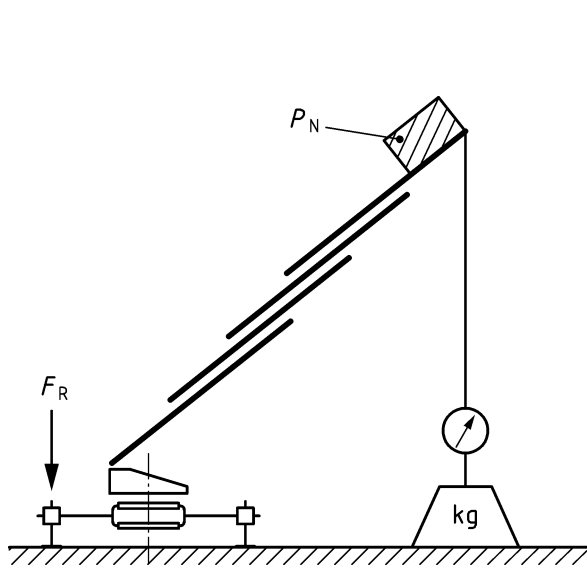

**Key**  
 $F_R$  residual force  
 $P_N$  nominal load

**Figure 9 — Test position without rescue cage**

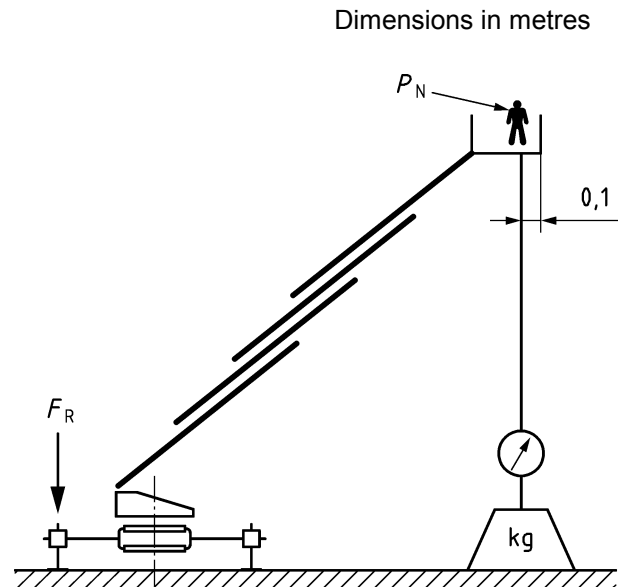

**Key**  
 $F_R$  residual force  
 $P_N$  nominal load

NOTE See 5.1.2.1.2.

**Figure 10 — Test position with rescue cage**

**5.1.2.3.4** In the event of failure of the main power source (vehicle engine or e.g. hydraulic pump) the machine shall be designed so that the turntable ladder can return safely under maximum loading from each position to the driving position by means of an emergency drive system. Where the emergency operating system is to be operated manually, the machine shall be designed so that the generation of the power that is necessary for operating this system is in a safe and secure position.

All controls contributing to emergency operation of the ladder shall be identifiable.

Emergency operation of the ladder shall be described in the instruction handbook.

Verification:

Verification method 1 (only reception test):

Stabilize the turntable ladder.

Position the ladder set so that the elevation angle  $\alpha$  is as low as possible.

Apply the maximum authorized load.

*Disconnect the main power source.*

*Visually check if all controls contributing to emergency operation are identifiable.*

*Verify that each of the following movements can be carried out using the emergency system:*

- raising;*
- lowering;*
- extending;*
- housing;*
- slewing;*
- levelling.*

*NOTE* *Movements through their entire range are not necessary for this verification.*

*Verification method 2 (at least type test):*

*Visually check if all controls contributing to emergency operation are identifiable.*

*Stabilize the ladder at its maximum jacking width on a gradient between 5° and 7° with rescue cage without load and then*

- elevate the turntable ladder to an angle  $\alpha$  equal to  $(75 \pm 2)^\circ$ , at maximum extension, and slew to an angle  $\theta$  of  $(90 \pm 2)^\circ$ ,*
- disconnect the main power source,*
- measure the time to reach transport position.*

**5.1.2.3.5** The machine shall be designed so that all ladder movements can be performed using the emergency operating system in the event of failure of the normal control system.

An audible signal complying with EN ISO 7731 shall be sounded when the emergency operating system is switched on and shall be continuous throughout the whole operating period.

See also 5.1.5.5.

*Verification:*

*Stabilize the turntable ladder.*

*Position the ladder set in any position except for the transport position.*

*Simulate a breakdown of the normal control system (for example: fault in ladder extended length indicator).*

*Set up the emergency system as described in the instruction handbook.*

*Verify that each of the following movements can be carried out using the emergency system:*

- raising;*

- lowering;
- extending;
- housing;
- slewing;
- levelling;
- moving to travel position.

*NOTE* Movements through their entire range are not necessary for this verification.

*Confirm that the audible signal sounds throughout the operating period.*

**5.1.2.3.6** When the ladder is not in transport or travel position, all safety systems shall remain energized and operational in case of deliberate or accidental interruption of the main power source (vehicle engine). The performance of the battery shall be at least 135 Ah.

An audible alarm shall be provided which sounds before the battery voltage falls below the limit which enables the engine to start.

Verification:

*Functional verification and design check.*

### **5.1.3 Requirements relating to the strength of the turntable ladder**

#### **5.1.3.1 General**

A static overload test is necessary to confirm the design calculations of the manufacturer of the ladder set.

The turntable ladder shall show no permanent deformation after testing which might impair its ability to function.

#### **5.1.3.2 Test at the boundary of free-standing use with $\alpha_{\max}$**

The test load shall be as follows:

$$P_p = 1,5 \times P_N + P_Z, \text{ for ladders equipped with a rescue cage.}$$

180 kg shall be used for the ladders not equipped with a rescue cage.

The difference in height measured before and after unloading shall be less than 10 cm.

Verification:

*Support the turntable ladder on a hard and essentially horizontal base.*

*Carry out the test within the longitudinal axis of the vehicle, ladder set pointing backwards ( $\theta = 180^\circ$ ).*

*Support the turntable ladder with the maximum jacking width.*

*Without a rescue cage:*



*For the purposes of the testing, pitch the ladder with the maximum possible elevation angle  $\alpha$  and the maximum possible extension  $L$  and with the “one person at top of the ladder” load selected, the lowering control is operated until the movement is stopped automatically.*

*Apply the test load static to the highest rung to avoid any dynamic effects, for duration of 10 min.*

*After unloading, check that the difference in height of the highest rung measured before and after unloading is less than 10 cm.*

*After carrying out this test verify that a cycle identical to the 13th cycle as specified in 5.1.4.1 is possible.*

*With a rescue cage:*

*For the purposes of the testing, pitch the ladder with the maximum possible elevation angle  $\alpha$  and the maximum possible extension  $L$  and with the “3 persons in the rescue cage” load selected, the lowering control is operated until the movement is stopped automatically.*

*Apply the test load static at the centre of gravity of the rescue cage base for 10 min.*

*After unloading, check that the difference in height of the rescue cage floor measured before and after unloading is less than 10 cm.*

*After carrying out this test verify that a cycle identical to the 13th cycle as specified in 5.1.4.1 is possible.*

### **5.1.3.3 Test at supported boundary (with or without rescue cage if it can lean to the supporting point)**

The test load corresponding to the number of persons (90 kg each) specified by the manufacturer shall be equally distributed on the horizontally supported ladder. The minimum test load shall be equivalent to the mass of 8 persons.

#### Verification:

*Support the turntable ladder on a hard and essentially horizontal base.*

*Carry out the test within the longitudinal axis of the vehicle, ladder set pointing backwards ( $\theta = 180^\circ$ ).*

*Support the turntable ladder with the maximum jacking width.*

*Pitch the ladder without rescue cage to an elevation angle  $\alpha$  of  $(0 \pm 3)^\circ$ .*

*The extension movement is operated until automatically stopped at the boundary of use for “bridging, no rescue cage”.*

*Provide and position a support bearing across the width of the ladder between 25 cm and 30 cm below the last rung. Apply the load to the rung closest to the middle of each section of the ladder, for 10 min.*

*After carrying out this test verify that a cycle identical to the 13th cycle as specified in 5.1.4.1 is possible.*

## **5.1.4 Verification of vehicle performance by functional testing**

**5.1.4.1** This test is to ensure the correct operation of all functions of the turntable ladder.

NOTE For special devices not covered by this European standard the vehicle manufacturer is responsible for carrying out a risk analysis to determine the necessary protective measures.

For ladders with rescue cage,  $P_p = P_N + P_Z$  shall be used as the test load where  $P_N$  corresponds to the maximum number of persons, each of mass 90 kg, permitted in the rescue cage. For ladders without a rescue cage,  $P_p = 180$  kg shall be used as the test load.

Verification:

*The ambient temperature shall not exceed 35 °C.*

*The temperature of the hydraulic fluid shall not exceed 35 °C at the start of testing.*

*The wind velocity acting on the ladder shall not exceed 12,5 m/s during the course of the tests.*

*Stabilize the turntable ladder on hard surface.*

*Position the turntable ladder at a camber angle  $\beta = (7 \begin{smallmatrix} 0 \\ -1 \end{smallmatrix})^\circ$ .*

*The test load shall be as indicated in 5.1.4.1, § 2.*

*At the start of testing, the ladder is pitched such that the slewing angle  $\theta = (180 \pm 3)^\circ$ , elevation angle  $\alpha = (0 \pm 3)^\circ$  and extension  $L =$  minimum extension.*

*The test shall comprise of 12 loaded cycles and is to be finished within  $(30 \pm 5)$  min.*

*One loaded cycle comprises simultaneously slewing of the turntable ladder once through  $(90 \pm 3)^\circ$ , raising once until automatic stop at the maximum elevation limit and extending once until automatic stop at the maximum extension limit, then, after a holding period of  $(20 \pm 1)$  s, return of the turntable ladder to the original position.*

*The time interval between subsequent loaded cycles shall be  $(15 \pm 1)$  s.*

*After normal completion of the 12th cycle, remove the load from the ladder or rescue cage, as appropriate, and then execute a 13th cycle by means of an operator from the control console on the turntable ladder or in the rescue cage if fitted.*

*Verification is achieved if the 13th cycle proceeds normally.*

**5.1.4.2** The ladder loaded to 90 kg shall be able to maintain its position for 10 min with a variation less than 150 mm when no other movement control is operated.

Verification:

*This test is the first to be carried out after the vehicle has been garaged at least 12 h.*

*The ambient temperature shall not exceed 35 °C.*

*The hydraulic fluid temperature shall be less than 35 °C.*

*The wind velocity acting on the ladder shall not exceed 12,5 m/s during the course of the tests.*

*The point of application of the test load shall be:*

- in the case of turntable ladders without rescue cage: the last rung of the ladder;*
- in the case of turntable ladders with rescue cage: at the centre of gravity of the rescue cage base.*

*Pitch the ladder with its rescue cage, if fitted, loaded to 90 kg, with slewing angle  $\theta = (90 \pm 3)^\circ$ , angle of elevation  $\alpha = (45 \pm 3)^\circ$  and the ladder set fully extended to its permitted maximum. The rescue height in the foregoing configuration is measured and subsequently repeated after 10 min. Verify that the difference between the two measurements does not exceed 150 mm. Record the result in the test report.*

## **5.1.5 Requirements relating to function**

### **5.1.5.1 Power transmission**

There shall be an interlocking system on the chassis which prevents the chassis from driving if the ladder is not in the transport position.

Verification:

*Stabilize the ladder vehicle.*

*Carry out a function test to demonstrate that it is not possible to transmit power to the drive wheels of the vehicle as long as the power take-off is activated.*

*Switch off the motor for a random period and then re-start.*

*Carry out a function test to demonstrate that it is not possible to transmit power to the drive wheels of the vehicle and to drive the vehicle.*

### **5.1.5.2 Jacking**

**5.1.5.2.1** Turntable ladders constructed to be operated only with the rear axle suspension fully or partially locked shall incorporate systems preventing operation if the suspension is not locked in the position specified in the instruction handbook.

Verification:

*Visual and functional examination.*

**5.1.5.2.2** Turntable ladders shall have interlocking between the power supplies to the jacking system and the ladder set moving system.

The machine shall be designed so that the jacking system cannot be operated when the ladder is not in its transport position.

Verification:

*Functional test and design check.*

**5.1.5.2.3** Turntable ladders shall incorporate a device preventing operation of the turntable ladder from the transport position until the jacking system is deployed, in position and operating satisfactorily.

When tested for movement, the turntable ladder shall not move other than for automatic repositioning of the rescue cage where necessary.

Verification:

*The turntable ladder shall be in the transport position. Move the jacks to any position other than the correct jacking position specified by the manufacturer.*

*Carry out a function test for movement of the turntable ladder. Check that no movement, other than the automatic repositioning of the rescue cage, where necessary, is possible.*

**5.1.5.2.4** Turntable ladders with powered jacking systems shall be provided with a device preventing movements of the jacking system unless the ladder set is in transport position.

Verification:

*Stabilize the vehicle.*

*Move the ladder set to any position.*

*Carry out a functional test to demonstrate that the jacks cannot be moved.*

**5.1.5.2.5** Devices shall be provided preventing unintentional movements of the jacking equipment and the suspension locking systems. See also 5.1.5.9.

Verification:

*Carry out a design check to determine whether suitable devices are provided and operate correctly for the purpose of preventing inadvertent movements of the jacks or the suspension locking system (e.g. as a result of break of a supply line in hydraulic devices).*

*Carry out a visual inspection to confirm the presence of such devices.*

**5.1.5.2.6** The vehicle shall not slip while jacked or while being stabilized in accordance with the manufacturer's instructions on the maximum permitted gradient.

Verification:

*Stabilize the vehicle at the maximum gradient permitted by the manufacturer.*

*The test shall be carried out on a wet surface, operating the ladder to reach the boundaries of free-standing use and supported use.*

*Visual verification of non-slipage.*

**5.1.5.2.7** The jacks or the baseplates of the jacks shall be designed in such a way that they can compensate for local unevenness of the ground up to at least 15°.

Verification:

*Verify the dimensions.*

**5.1.5.2.8** The machine shall be designed to compensate for depressions up to 50 mm without using blocks on a horizontal bearing surface.

Verification:

*Park the turntable ladder with 50 mm high blocks under each wheel.*

*Place the blocks on hard and essentially horizontal ground.*

*Check that it is possible to jack the ladder normally.*

**5.1.5.2.9** On a horizontal bearing surface, the jacking system shall accommodate bumps up to 150 mm without affecting stability.

Verification:

*Place the ladder vehicle on hard and essentially horizontal ground.*

*Position a 150 mm high block under one jack.*

*Check that it is possible to jack the ladder normally.*

**5.1.5.2.10** The jacking devices shall provide an electrically conducting connection between the turntable ladder and the bearing surface. Blocks shall also conform to this requirement.

Verification:

*Visual inspection.*

**5.1.5.2.11** Jacks which, when deployed, project beyond the outline of the vehicle shall incorporate suitable warning colours and warning flashing lights at their extremities.

The warning flashing lights shall be protected against mechanical damage.

Verification:

*Visual inspection.*

**5.1.5.2.12** The area of each baseplate of the jacks shall be of sufficient size such that the maximum pressure under each baseplate not to exceed  $80 \text{ N/cm}^2$  under the least favourable conditions of use of the ladder.

Verification:

*Support the ladder vehicle on hard, essentially horizontal ground with smallest jacking width.*

*Load the ladder with the maximum working load:  $P_L = P_N + P_Z$ .*

*Raise the ladder such that the elevation angle  $\alpha$  is as small as possible whilst allowing slewing  $\theta$  of the turntable ladder from  $0^\circ$  to  $180^\circ$  for free standing use.*

*Slew the ladder from  $0^\circ$  to  $180^\circ$ . Take care to ensure that the actual extension is not less than the extension permissible for the actual angle  $\theta$ . Measure the maximum force acting on each jack on the side of the ladder subjected to additional loading during the movement.*

*Measure the area of each jack.*

*Calculate the maximum pressure.*

*It is sufficient to carry out the test only on one side of the ladder.*

**5.1.5.2.13** The dimensions of the blocks supplied by the manufacturer for use under each jack shall be at least  $0,4 \text{ m} \times 0,4 \text{ m}$  or have at least a surface area equivalent to the area of the baseplate of the jack, if greater.

Verification:

*Measure the dimensions.*

**5.1.5.2.14** The ladder shall be designed so that, during its use, a foot cannot be placed under a jack base-plate because of a jack baseplate lifting as a result of loading. Any gap between ground and jack base-plate shall be less than 25 mm.

Verification:

*During the course of the dynamic stability tests, an inspection is carried out to ensure that any lifting of the jack feet is less than 25 mm.*

**5.1.5.2.15** Turntable ladders shall be equipped with an audible warning signal, which is actuated and maintained during movements relating to the jacks and the suspension locking mechanism.

Verification:

*Audible check.*

**5.1.5.2.16** The suspension locking device which renders the suspension totally or partially rigid shall operate regardless of the relative positions of the rear axles relative to the chassis resulting from ground undulations (at least 100 mm).

Verification:

*Stabilize the vehicle while putting a block of 100 mm height under a rear wheel to simulate the angular displacement of the axle relative to the chassis.*

*Verification is achieved if the axle lock can be engaged/disengaged without difficulty and without suffering any damage, the jacks can be positioned correctly and the ready-to-operate signal is initiated.*

**5.1.5.2.17** The static tilt angle  $\delta$  of turntable ladders of gross laden mass (GLM) according to EN 1846-2 shall not be less than the minimum values shown in Figure 11.

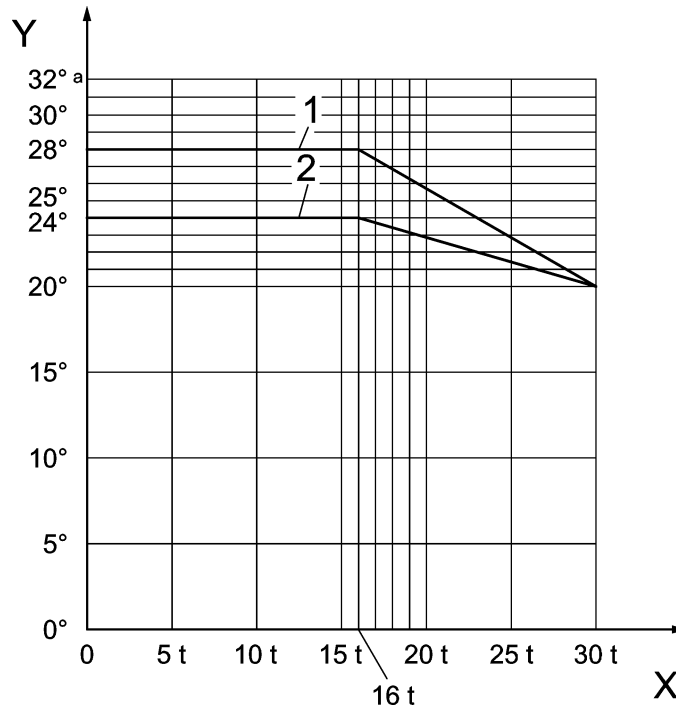

**Key**

- X gross laden mass (GLM) of vehicle in metric tonnes (t)
- Y static tilt angle  $\delta$
- 1 turntable ladders without 4-wheel drive
- 2 turntable ladders with 4-wheel drive
- <sup>a</sup> static tilt angle for fire fighting vehicles according to EN 1846-2, category 1

**Figure 11 — Static tilt angle  $\delta$  for turntable ladders**

Verification:

Testing in accordance with EN 1846-2:2009+A1:2013, 5.1.1.2

**5.1.5.3 Levelling**

**5.1.5.3.1** The turntable ladder shall have automatic levelling devices for the chassis or turntable ladder in order to ensure that the rungs and base of the rescue cage are horizontal if the bearing surface deviates from the horizontal.

The levelling equipment shall compensate automatically for deviations from the horizontal of the rungs and the floor of the rescue cage over the entire operating range of the ladder at an inclination of the bearing surface of up to at least 7°.

A levelling tolerance of 1,5° shall be permitted during manoeuvring and where the ladder is at rest.

Verification:

Carry out the test as follows at no load and at maximum working load:

Jack the ladder vehicle at a gradient angle of  $(7 \begin{smallmatrix} 0 \\ -1 \end{smallmatrix})^\circ$ .

*Pitch the ladder so that the elevation angle  $\alpha$  is less than  $70^\circ$  but allows one complete revolution of the turntable ladder.*

*Fit one of the first five rungs of the ladder with a gradient indicator recording the angular difference between this rung and the horizontal.*

*Record the angular difference between this rung and the horizontal throughout a  $360^\circ$  slewing operation at the maximum authorized speed.*

*A stop is effected perpendicular to the maximum gradient.*

*Make at least two extra random stops during the operation.*

**5.1.5.3.2** If the equipment for operating the levelling device may be switched off, a warning lamp on each control console shall indicate if the automatic levelling equipment is inoperative.

Verification:

*Carry out a visual examination where such a system is provided.*

**5.1.5.3.3** A device which automatically stops excessive levelling and other aggravating movement shall come into operation as soon as a vertical deviation of an amount specified by the manufacturer occurs.

NOTE The permitted vertical deviation is dependent on the operating conditions of the ladder and it is specified by the manufacturer.

Verification:

*Jack the ladder vehicle on a longitudinal gradient  $(3 \pm 1)^\circ$  greater than the maximum correction value specified by the manufacturer.*

*Position the ladder set so that the angle of elevation  $\alpha$  is less than the maximum angle of elevation minus the maximum correction factor specified by the manufacturer.*

*Fit one of the first five rungs of the ladder with a sensor to detect the angular difference between this rung and the horizontal.*

*Slew the turntable ladder at maximum authorized speed until the movement is automatically stopped.*

*Carry out a visual check of the horizontality of the rung with the recording device.*

*Jack the ladder on a lateral camber  $(3 \pm 1)^\circ$  greater than the maximum correction factor specified by the manufacturer.*

*Raise the ladder to the automatic stop.*

**5.1.5.3.4** The angle between the base ladder section and the horizontal shall not exceed  $(75 \frac{+2}{0})^\circ$ , no matter which inclination the under-carriage has (see Figure 12).



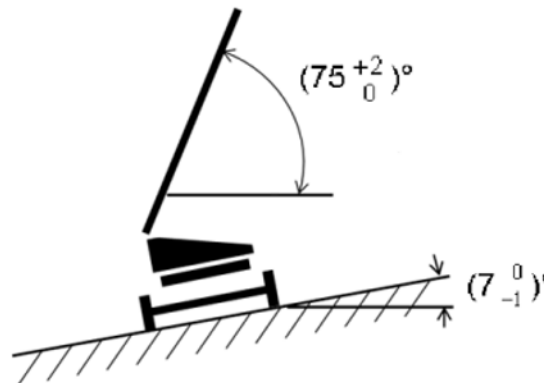

**Figure 12 — Maximum angle of elevation**

Verification:

*Jack the ladder vehicle on a gradient of  $(7 -1)^\circ$ .*

*Position the ladder set so that the angle of elevation  $\alpha$  is at its maximum permissible value.*

*Fit the last ladder section with a sensor device to determine the angular difference in angle between this section and the horizontal.*

*Carry out a slewing operation at maximum authorized speed up to the automatic stop of the movement.*

*Measure the angle between the last section of the ladder and the horizontal of the site.*

#### **5.1.5.4 Rescue cage**

**5.1.5.4.1** The load bearing component of the rescue cage shall have more than one device to maintain the floor of the cage in a horizontal position. The correction system shall maintain the horizontality of the rescue cage if load bearing components fail.

Verification:

*Carry out a visual check of the turntable ladder to confirm the presence of more than one correction device.*

**5.1.5.4.2** For turntable ladders equipped with a rescue cage, the levelling correction system of the horizontal axis of the rescue cage, when in the working position, shall be capable of following all ladder movements, the maximum permissible deviation being  $\pm 3^\circ$ , except during the periods of acceleration, deceleration and emergency stop.

Beyond  $12^\circ$  all aggravating movements shall be prevented, apart from emergency operation.

Verification:

*Support the ladder vehicle on hard and essentially horizontal ground.*

*Position the turntable ladder so that the angle  $\theta = (90 \pm 3)^\circ$  with the angle  $\alpha$  being the minimum admitted.*

*Place a sensor on the rescue cage base in the axis of the ladder so as to permit continuous reading of the angular difference between the rescue cage base and the horizontal.*

*Raise the ladder set to the maximum angle  $\alpha$  then lower to its initial position.*

*Record the angular difference between the rescue cage base and the horizontal.*

*Neutralize the rescue cage levelling system in this return position.*

*Place a sensor on the rescue cage base and raise the ladder set to the automatic stop. Note the reading from the sensor in the test report.*

*Verify that in this position only emergency operations and non-aggravating movements can be carried out.*

**5.1.5.4.3** Protection means shall be provided on all sides of the rescue cage in order to prevent persons and objects falling out.

Protective devices shall be securely fastened to the rescue cage and consist, as a minimum, of a handrail not less than 1,1 m high and a plinth not less than 0,15 m high, except at the access area of the ladder (see Figure 13 and 5.1.5.4.10). All apertures shall be designed such that a sphere of 350 mm diameter cannot pass through.

The handrail shall be designed so that the forces generated by the maximum number of permitted persons in the rescue cage do not cause any permanent deformation.

The guard-rails shall be designed so that they withstand stationary loads of 500 N applied in any direction without permanent deformation. The number of stationary loads applied simultaneously at intervals of 500 mm shall correspond to the maximum number of persons indicated in the rescue cage.

Hand protection against impact (upper guard rail, see Figure 13) shall be provided on all sides of the rescue cage. A handrail shall be provided at least over the entire length of the two sides and the front of the rescue cage in accordance with Figure 13.

Anchoring points for the indicated maximum number of persons in the rescue cage for the attachment of personal protective equipment for work positioning shall be fitted in the rescue cage (rated force at least 1 050 N per person). The structure of the rescue cage can also be used to provide anchorage points provided that it achieves at least the same level of security. Anchoring points or structures shall be appropriately marked.

Dimensions in millimetres

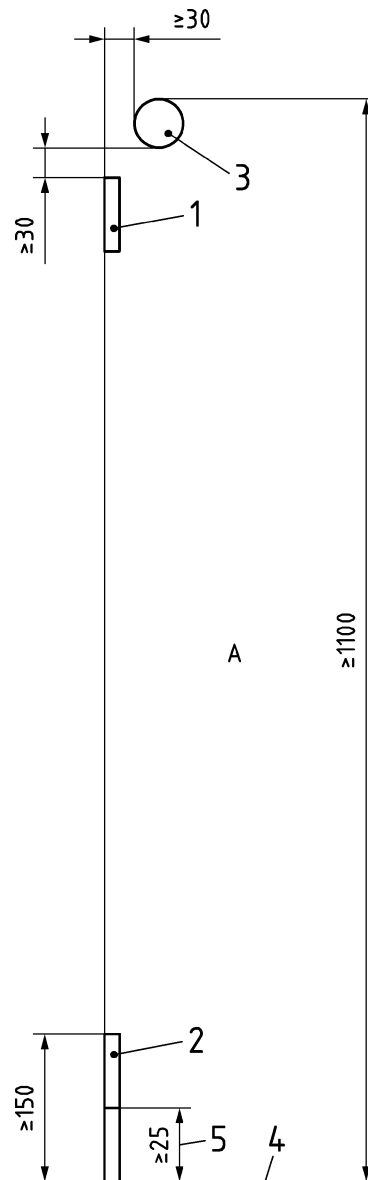

**Key**

- 1 upper guard rail
- 2 plinth
- 3 hand rail
- 4 rescue cage floor
- 5 access area to rescue cage
- A inside the rescue cage

**Figure 13 — Relative positions of hand and guard-rails**

Verification:

*Carry out a dimensional check and a visual check.*

*Carry out the strength test of the guard rails and anchorage points.*

**5.1.5.4.4** In general side doors in the rescue cage fencing shall open inwards. However if necessary for rescue purposes access doors may open outward or be sliding doors with the handrail permanently fixed or opening inwards or upwards. Opening sections of handrails shall not open outwards.

Door locking devices shall be designed in such a way that the lock is automatically engaged when the door is closed. Incorrect locking of the door shall be detectable by the operator.

The design of the doors shall prevent their inadvertent or unintentional opening. For this reason the locking device shall present no protruding parts by which it can be disengaged by parts of the body or by clothing.

Verification:

*Visual check and functional test.*

**5.1.5.4.5** The base surface of the rescue cage shall have a surface which is designed to reduce the risk of slipping (see EN 1846-2:2009+A1:2013, Annex C) and permit water to drain away. All apertures in the base or between base and plinth or access gates shall be designed such that a sphere of 15 mm diameter cannot pass through.

Verification:

*Carry out a check of the non-slip nature of the surface of the rescue cage (see EN 1846-2:2009+A1:2013, Annex C) and a check on the effectiveness of water drainage.*

*Ensure that a sphere of  $(15 \pm 0,5)$  mm diameter cannot pass through the rescue cage floor or at its edges.*

**5.1.5.4.6** If the turntable ladder is equipped with a removable rescue cage, the rescue cage shall be secured to the ladder by an automatic locking system.

The rescue cage shall unlock by two actions which are independent from each other.

The attachment system shall be designed to prevent the consequences of human error arising during the mounting of the rescue cage. The attachment system shall be designed to prevent incorrect attachment. Movement of the turntable ladder shall be prevented in the event of a fault in the connection (mechanical, electrical, hydraulic, etc.) of the rescue cage to the ladder. When the overriding of this blocking of movement is necessary to remove or attach the rescue cage, audible and visual warnings shall be given.

Fitting or removal of the rescue cage from its mountings (e.g. chassis deck, turret), where applicable, as well as its attachment to or removal from the ladder set shall be achieved by the means specified in the instruction handbook.

The stowage position of the rescue cage, when not at the extremity of the ladder set (e.g. chassis or turret), shall be such as to not interfere with any ladder movements.

Quick and easy removal, hanging, landing and placing of a removable rescue cage shall be possible.

Verification:

*Confirm that the locking system necessitates two separate actions for unlocking.*

*Create defects in attachment and connections (mechanical, electrical and hydraulic). Verify that in each case all ladder set movement is prevented.*

*Visual inspection and functional test of the attachment and overriding function that the audible and visual warning works correctly.*

*Check that removal, hanging, landing and placing of the rescue cage, if removable, can be carried out quickly and easily.*

**5.1.5.4.7** The rescue cage mounting device shall be capable of supporting the weight of the rescue cage plus 4 times the maximum working load.

Verification:

*Support the first (upper) section of the ladder to prevent overload.*

*Load the rescue cage gradually in order to minimize the dynamic effects with a load equal to 4 times the working load  $P_L$ .*

*Maintain the test load for 10 min.*

*Immediately after removing the load from the rescue cage, visually check then raise and lower it to ensure that no functional fault has been caused.*

**5.1.5.4.8** Any risk of crushing or shearing between the rescue cage and ladder during any movement including when the ladder is being extended or housed shall be prevented (see 5.1.5.4.3, 5.1.5.4.4, 5.1.5.5.3 and Clause 7).

Verification:

*Carry out a visual check in all configurations within the area of use.*

**5.1.5.4.9** In all positions of the ladder the clear width between the cage and ladder shall not exceed 0,3 m to achieve safe transfer between the rescue cage and the turntable ladder set. Handrails to be used during the transfer shall be provided. Handles and/or hand holds shall be provided to enable 3 point support at any time when using this access.

Verification:

*Carry out a dimensional check and test for access from the rescue cage to the ladder set.*

**5.1.5.4.10** The width of all access openings to the rescue cage shall be between 0,45 m and 0,6 m. The height of the access openings shall be greater than 0,9 m.

A plinth with a height of at least 2,5 cm and no more than 10 cm shall always be provided across the access areas.

Verification:

*Dimensional verification.*

**5.1.5.4.11** Any accessories provided by the manufacturer for installation within the rescue cage shall be fastened in place by mechanical locking.

Verification:

*Visual check and functional test.*

**5.1.5.4.12** The rescue cage shall be equipped with a working light, mounted within the protection of the rescue cage. The working light shall illuminate an area having a width of 10 m and a depth of 15 m from the working light with a minimum light intensity of 5 lx. Depending on the direction of the working light, the working light can however protrude from the rescue cage outline. The working light may be detachable.

Verification:

*Visual check and documentation of working light.*

**5.1.5.4.13** The useable area  $A$  of the rescue cage and the number of persons permitted in the rescue cage  $N$  shall comply with the following formula:

$$0,2 \text{ m}^2 \leq \frac{A}{N} \leq 0,25 \text{ m}^2 \quad (4)$$

where

$A$  is the useable area of the rescue cage, expressed in square metres;

$N$  are the number of persons permitted in the rescue cage.

Verification:

*Dimensional check.*

**5.1.5.4.14** A device shall stop all movements in case of impact between the rescue cage and the obstruction according to Figure 14.

Verification:

*Place the rescue cage in contact for each direction as defined in Figure 14 and confirm that the movement stops for each contact.*

The machine shall be designed so that at least reverse movements can be performed in case of contact with an obstacle.

Verification:

*Functional test.*

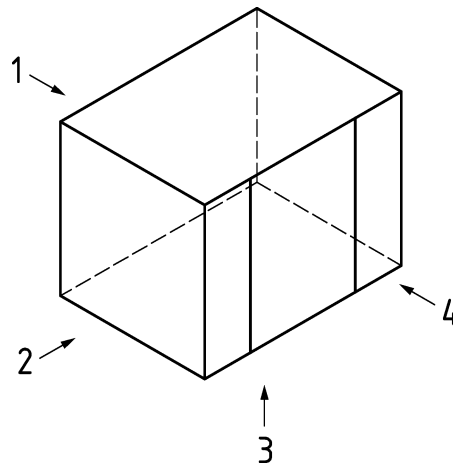

**Key**

- 1 front impact
- 2 side impact
- 3 lower impact
- 4 rear impact, e.g. on left side

**Figure 14 — Impact simulation on the rescue cage**

**5.1.5.5 Control and function control consoles**

**5.1.5.5.1 General**

**5.1.5.5.1.1** The controls shall be designed and arranged such that

- for the three main movements of the ladder (extending/retracting, raising/lowering and slewing) the movement of the control lever is consistent with the effect required;
- except for an emergency stop, they can execute movements with limited shock;
- they are easily visible and identifiable;
- they are appropriately marked.

Safety related parts of the control system shall be at least Performance level (PL) according to EN ISO 13849-1 as shown in Table 4.

**Table 4 — Functional Safety and Performance Level**

Clause in this document	Topic	Performance level (PL) according to EN ISO 13849-1
5.1.2.3.1 and 5.1.2.3.2	Stability	d
5.1.2.3.3	Moment sensing system	d
5.1.5.2.2 to 5.1.5.2.5	Pressure release superstructure / undercarriage	d
5.1.5.3	Terrain compensation ladder set	c
5.1.5.4.1 and 5.1.5.4.2	Rescue cage leveling	d
5.1.5.5.1	Prevention of unintended movement	c

Verification:

*General visual check and functional test including the following for each movement, individually and in combination:*

- *movement in all permitted directions and combinations;*
- *application of the emergency stop whilst maintaining the position of the actuator for the movement involved in the “on” position;*
- *resetting of the emergency stop device whilst maintaining movement control;*

*Verify whether movement is in the indicated direction or, when appropriate, movement is stopped or prevented.*

*Design check of the safety related parts of the control system.*

**5.1.5.5.1.2** In the event of interruption of a ladder movement (e.g. caused by an emergency stop, power failure, etc.), resumption of ladder movements in progress before interruption shall be initiated only by moving the appropriate lever from its “stop” or “zero” position.

Verification:

*Visual check and functional test.*

**5.1.5.5.1.3** Control consoles for the turntable ladder shall be provided with non-glare illumination adequate to ensure normal use under all external lighting conditions.

Verification:

*General visual check and functional test.*

**5.1.5.5.1.4** Control consoles shall be designed and located so that the operator:

- can operate the controls without hindrance,
- is not put at risk by movements of the turntable ladder,
- is not exposed to the risk of falling.

Verification:

*General visual check and functional test.*

**5.1.5.5.2 Jacking control console(s)**

The symbols on the control console shall conform to CEN/TS 15989.

The control consoles for the variable width jacking systems shall be located so that the operator has clear vision of each jack during operation. When the jacking system is inside the vehicle contour, it is not necessary to have sight of all moving jacks at once.

The operating controls shall be of the hold-to run type.

The jacking control consoles shall have an emergency stop in addition to the normal control to stop jacking movements.



An optical device shall be provided on the control console(s) for the jacking system indicating that the vehicle is stabilized and normal use of the turntable ladder may be undertaken.

Verification:

*Visual check and functional test.*

**5.1.5.5.3 Main control console**

The turntable ladder shall have a main control console for operation of the ladder set.

The functions of the main control console shall comply with Table 5.

**Table 5 — Functional requirements for ladder set main control console**

<b>Function</b>	<b>Control/Action</b>
Elevation	Hold-to-run control
Depression	Hold-to-run control
Extending	Hold-to-run control
Housing	Hold-to-run control
Slewing right	Hold-to-run control
Slewing left	Hold-to-run control
Emergency stop	Control device, etc. with symbol according to EN 61310-1
Rung alignment	Actuated by hold-to-run control
Limit of free standing use attained for the load selected and width of stability achieved	Continuous audible warning
Alignment with central axis of the vehicle	Yellow guide mark visible from console
True angle of elevation	Visual information
True extended length	Visual information
True projection	Visual information
Maximum projection	Visual information
True height	Visual information
Maximum height	Visual information
Manoeuvre of ladder overriding rescue cage control emergency stop	Operated by hand; Re-energizing
Dead man's device	Operated by foot pedal necessitating sustained pressure
Ladder set illumination	Control switch, button, etc.
Rescue cage emergency stop muting and/or restarting	Push button

NOTE For graphical symbols on the control console, see CEN/TS 15989.

The main control console shall be equipped with an emergency stop control of stop category 0 or stop category 1 which shall conform to EN ISO 13850:2008, 4.1.4 to 4.1.6.

The main control console shall be fixed to and, at least, rotate with the turntable. A remote control system is not permissible.

Illumination of the access to the main control console from the vehicle deck shall permit its safe and easy use under all light conditions (both during the day and at night).

Access to the main control console from the vehicle deck shall be in accordance with EN 1846-2.

Hand grips or rails shall be provided at three points simultaneously when using this access thus preventing inadvertent contact with the control levers.

Controls for extending/retracting, raising/lowering and slewing left/right shall enable a controlled change in the speed of the resulting movement. The machine shall be designed so that the movements of the ladder set and all equipment for controlling and monitoring the operation of the ladder can be seen in any position from the main control console.

The machine shall be designed to start and stop the engine with one control device.

The machine shall be designed so that

- the main control console cannot be used until the jacking system is deployed and locked, except for the emergency stop;
- the functions “raise/lower”, “extend/house” and “slew right/left” cannot be performed without the prior and continuous operation of the dead man's device;
- the movement cannot be performed without preliminary reset if control(s) is(are) activated before activation of the dead man's device;
- the corresponding movement(s) cannot be performed without the prior and continuous operation of the dead man's device;
- movement can always be controlled from the main control console, even if the emergency stop control of the rescue cage has been activated;
- movement via the control lever of the rescue cage control console can only be performed after unlatching the emergency stop control in the rescue cage.

The controls in the main control console shall be capable of overriding the controls in the rescue cage control console, if fitted, with the exception of the rescue cage emergency stop control.

An indicator (e.g. display) readable from the main control console shall show the actual values of ladder length, projection and elevation angle together with the maximum achievable values, all with a tolerance of 4 %.

Verification:

*Verify throughout the tests that indicator readings agree with current values with a tolerance of 4 %.*

*Visual check and functional test:*

a) *for the ladder only, subject each of the controlled movements to the following test:*

- 1) *action just on the control lever (no action on the dead man's device). Check that there is no movement;*

- 2) *action on the control lever followed by activation of the dead man's device. Check that there is no movement;*
  - 3) *during a movement, interrupt activation of the dead man's device. Check that the movement stops immediately and safely;*
  - 4) *during a movement, interrupt action on the control lever. Check that there is a controlled stop of the movement;*
  - 5) *check that during an application of the emergency stop device there is an immediate safe stop;*
- b) *for the ladder with rescue cage carry out the following supplementary test:*
- 1) *emergency stop action in the rescue cage. Check that there is an immediate safe stop of the movement;*
  - 2) *confirm that it is possible to carry out all the movements again from the main control console after resetting the emergency stop device;*
  - 3) *execution of a movement from the rescue cage;*
  - 4) *Check that an execution of a different movement from the main console is possible. Verify that during this stage the main control console is able to override the rescue cage controls (with the exception of the rescue cage emergency stop).*

#### **5.1.5.5.4 Rescue cage deployment control console(s)**

Control console(s) shall enable the deployment of the rescue cage (travel and working position) from a position which gives a view of the controlled movement.

The working position (use) and the travel position control(s) shall be a hold-to-run.

##### Verification:

*Visual check and functional test. Carry out the test 5.1.5.5.3 b) from the control console in the rescue cage.*

#### **5.1.5.5.5 Control console in the rescue cage**

The rescue cage shall have an emergency stop device of stop category 0 or stop category 1 which shall conform to EN ISO 13850:2008, 4.1.4 to 4.1.6.

A control console shall be installed in the rescue cage. It shall be integral to or able to be fixed in and located completely within the rescue cage.

Controls for extending/retracting, raising/lowering and slewing left/right shall enable a controlled change in the speed of the resulting movement.

The controls for the raise/lower, extend/house and slew left/right functions shall only be operable after actuation of a "dead man's device".

Ceasing operation of either of the two devices (movement controls and dead man's device) shall lead to a halt in the corresponding movement.

Activation of the dead man's device shall be necessary prior to the activation of movement control to achieve the corresponding movement.

The control console shall be located at the forward end of the rescue cage to enable unrestricted view of the operating area during ladder operation.

Equipment mounted on and/or in the rescue cage shall not prevent the operation of the control console.

Verification:

*Visual check and functional test. Carry out the second part of the tests in 5.1.5.5.3 from the control console in the rescue cage.*

#### **5.1.5.5.6 Illumination of the operating area**

The turntable ladder shall be equipped with a floodlight which can illuminate all areas within the operating area.

Verification:

*Visual check and functional test.*

#### **5.1.5.5.7 Additional functions**

The symbols of additional ladder functions shall conform to CEN/TS 15989.

Verification:

*Visual check.*

#### **5.1.5.6 Guy lines**

The ladder set shall be supplied with two guy lines wound on a device.

The ladder set shall have two fastening points for the guy lines at its head.

The guy lines shall be made from a rot-resistant material and shall be of a length fit for the intended purpose.

Verification:

*Visual check, functional test and measurement of the length.*

#### **5.1.5.7 Cradle/turret**

**5.1.5.7.1** The cradle/turret set on the turntable ladder shall have a protective device to prevent risks arising from crushing, shearing or contact during slewing, raising/lowering and levelling movements.

Verification:

*Visual check and functional test.*

**5.1.5.7.2** The position of the turret/cradle and all its parts shall be clearly indicated by flashing lights so as to be visible to an observer situated in any position in the access zone and/or the zone of operation of the turret/cradle where a person is not visible to the operator.

Verification:

*Visual check.*

**5.1.5.7.3** A diagram clearly indicating all lubricating points, the lubricants to be used and the lubrication intervals shall be affixed at a clearly visible suitable point.

Verification:

*Visual check.*

#### **5.1.5.8 Ladder set**

**5.1.5.8.1** The ladder set shall have lighting equipment with a range greater than the maximum extended length  $L$  and which can be switched on from the main control console.

Verification:

*Visual check and functional test.*

**5.1.5.8.2** Chain and cable drums, where provided, shall have a device preventing any hazard from trapping whilst in motion for extending or housing.

Verification:

*Visual check.*

**5.1.5.8.3** Access to the ladder set, in transport position, from the chassis deck shall comply with EN 1846-2:2009+A1:2013, 5.1.2.3.

Verification:

*Visual check, functional test and check of the dimensions specified in EN 1846-2.*

**5.1.5.8.4** A voice communication system with the main control console shall be provided at the head of the ladder set and in the rescue cage if fitted. The system shall be energized as soon as the ladder leaves the gantry or if equipped with a rescue cage when the ladder is in the working position. The machine shall be designed so that the voice communication system cannot be switched off. The communication from the rescue cage/ladder set to the main control console shall be permanently activated. The machine shall be designed so that the communication from the main control console to the rescue cage/ladder set can only be performed by an intentional activation.

Verification:

*Functional test.*

**5.1.5.8.5** A device shall ensure that the rungs of different sections of the ladder set are aligned with a permissible rung offset  $J$  according to Figure 15 in order to ensure continuity of passage along the ladder. In case of automatic operation, it is required to achieve rung alignment only during housing movement. It shall be capable of being interrupted on demand.

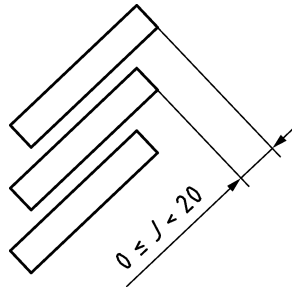

**Key**

$J$  permissible rung offset

**Figure 15 — Rung alignment**

Verification:

*Visual check, functional test and dimensional check.*

**5.1.5.9 Hydraulic circuit**

The design and selection of components shall conform to the requirements of EN ISO 4413.

Protective measures shall be taken to ensure that no hazard can arise to persons in the event of rupture (protective casings or fitting within protected areas).

The machine shall be designed so that pressure gauges (test port(s)) can be installed in each sector of the hydraulic system.

The system shall be capable of being bled of entrained air.

Hydraulic reservoirs in contact with the atmosphere shall be equipped with air inlet filters.

Hydraulic reservoirs shall be provided with a means of indicating the level of liquid and shall include maximum and minimum fluid level values. The relative positions of the pistons in rams shall be indicated alongside fluid level indicators.

The hydraulic system should be fitted with replaceable filters capable of passing all the liquid in the system at maximum flow rate.

Determine, by means of calculations and tests, the maximum pressures permissible throughout the various parts of the circuit.

Rams, pipes and their unions which can be subjected to a maximum pressure determined by a pressure relief valve shall be capable of resisting a pressure of at least 1,5 times the maximum working pressure without suffering permanent deformation (yield strength  $R_p 0,2$ ). Components which are liable to be subjected to greater pressures than those governed by the pressure relief valve shall be capable of resisting a pressure of at least 1,5 times the rated maximum without suffering permanent deformation (yield strength  $R_p 0,2$ ).

The bursting pressure of flexible hoses and their unions which can be subjected to the maximum pressure determined by the pressure relief valve shall not be less than three times the maximum rated pressure.

If, throughout the system, there are a number of different maximum pressures, a sufficient number of appropriately set pressure relief valves shall be provided. The machine shall be designed so that adjustment to pressure relief valves can only be made with the use of tools. The valves shall be capable of being sealed or otherwise protected from interference.

Verification:

*Design verification and functional test.*

#### **5.1.5.10 Electrical circuit**

Design and selection of the electric and electronic components shall comply with the requirements of EN 60204-1.

Electrical/electronic circuits and controls shall have a level of protection appropriate to the requirements of the operational environment to avoid malfunctions due to an inadequate protection type. The minimum degree of protection shall be IP 54 according to EN 60529 existing for all electric/electronic components.

The cables and connections of electrical circuits shall be protected to prevent damage causing short circuits.

Fuses shall be marked in a suitable way according to the maximum capacity permitted in the electrical circuit of an installation.

If electrical circuits of higher voltage (e.g. 230 V) are installed together with the electrical circuits of the vehicle in the same terminal box, the terminals or junction points of the circuits with the higher voltage shall be marked with the value of the maximum voltage. The requirements of EN 60204-1:2006, 13.1.3 shall also be fulfilled.

Cables and individual lines shall be marked by means of colours or numbers to avoid confusions.

Cables and conductors shall be flexible and resist all foreseeable environmental conditions (temperature, humidity, light, ultraviolet, chemical and mechanical stress) and shall be installed in a suitable manner.

In case of high mechanical loads acting from the outside on cables and lines, protective tubes shall be used.

If high tractive forces apply on cables and lines, discharging measures have to be taken for the cables by means of traction equipment. During installation and use, cables and lines shall have at least the minimum radii recommended by the manufacturers.

Verification:

*Visual check, functional test and design verification.*

#### **5.1.5.11 Chassis deck/Walkways/Access**

**5.1.5.11.1** The chassis deck shall have a surface which is designed to reduce the risk of slipping (see EN 1846-2:2009+A1:2013, Annex C).

Verification:

*Carry out a check of the non-slip nature of the surface of the chassis deck (see EN 1846-2:2009+A1:2013, Annex C).*

**5.1.5.11.2** The machine shall be designed so that access from the ground can be achieved regardless of the position of the ladder set at least by two points.

Access to the turntable ladder from the ground shall be in accordance with EN 1846-2, when the ladder is stabilized on a hard and essentially horizontal base. Hand grips or rails shall be affixed so that a user of this access can be supported at three points simultaneously when using this access.

Verification:

Visual check, functional test and measurement of the dimensions.

**5.1.5.11.3** The chassis deck area shall be free of all obstacles which may hinder its safe use.

Verification:

Visual check.

**5.1.5.11.4** Ladder rungs shall be provided with a protective covering. The protection shall have the following properties:

- slip-resistant;
- weather-resistant;
- easy to replace;
- shall not retain water;
- non-porous;
- designed to avoid risk of injury;
- providing good grip.

Verification:

Visual check and functional test.

**5.1.5.11.5** The ladder shall conform to the dimensions given in Table 6, Figure 16 and Figure 17.

With the exception of any means of supplying water, the top most ladder section (1; see Figure 3) shall enable free passage in accordance with Figure 16.

**Table 6 — Dimensions**

Dimensions in millimetres

<i>A</i>	<i>B</i>	<i>C</i> <sup>a</sup>	<i>D</i>	<i>E</i>	<i>F</i>
≥ 450	≥ 280	≥ 280	20 ≤ <i>D</i> ≤ 50	250 ≤ <i>E</i> ≤ 300	20 ≤ <i>F</i> ≤ 60
<sup>a</sup> Minimum available length for the rung covering. Dimension <i>C</i> is not shown in Figure 16 and Figure 17.					



Dimensions in millimetres

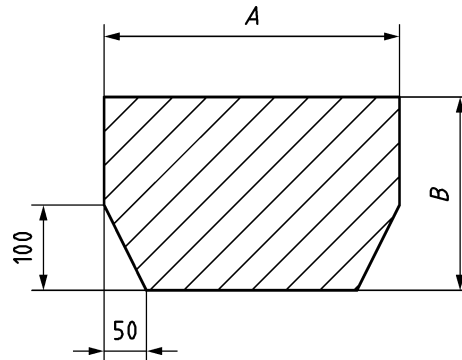

**Key**

*A, B* see Table 6

**Figure 16 — Minimum dimensions of ladder sections**

The rungs shall be manufactured from closed rectangular profiles. The spacing between the rungs *E* shall be constant over the entire ladder.

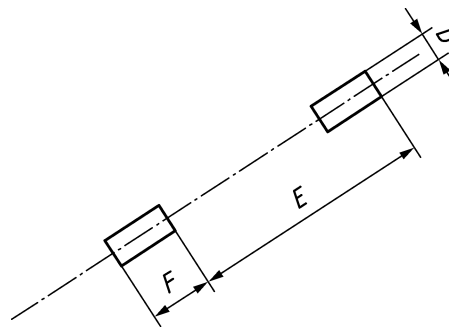

**Key**

*D, E, F* see Table 6

**Figure 17 — Rung spacing dimensions**

Verification:

*With the exception of any means of supplying water, verify that the first (upper) ladder section enables free passage in accordance with the template shown in Figure 16.*

*Carry out a dimensional check of the ladder rung characteristics.*

**5.1.5.11.6** The machine shall be designed to mount to and alight from the vehicle deck, main control console and ladder, whatever the position of the ladder set.

Verification:

*Visual check and functional test.*

#### **5.1.5.12 Monitoring/Controlling/Regulating software**

**5.1.5.12.1** The safety related parts of the control system including programmable electronics shall be designed in accordance with 5.1.5.5.1.1 and to the following principles. If, in particular cases, these principles are not completely in line with the requirements of 5.1.5.5.1.1, the latter shall take precedence.

**5.1.5.12.2** If the control of the turntable ladder is monitored/regulated by programmed software with processors, at least all processors and memory modules shall be tested for correct operation at start-up.

**5.1.5.12.3** At start-up and throughout the operation of safety related control/monitoring systems, the correct operation of all sensors and detectors shall be verified.

**5.1.5.12.4** In the event of a failure in the power supply to the monitoring control and regulating system, outputs shall be automatically switched off or put in the safe condition.

Once correct power supply is restored, the machine shall be designed so that resumption of the movements can only be performed by the intentional operation of a control by the operator.

**5.1.5.12.5** In the event that a fault cannot be detected in a logical safety-related sensor or its connection, the transmitted information by the sensor or its connection shall not lead to a dangerous situation.

**5.1.5.12.6** Sensors shall be monitored to detect out of range outputs.

**5.1.5.12.7** If the control/monitoring does not enable a control/monitoring cycle, it shall be verified that the real, kinematic and dynamic requirements of the whole system are fulfilled.

**5.1.5.12.8** The correct sequence of the programme shall be secured by a device/equipment (watchdog), which acts on safety-related output and in the event of a failure leads to a safe condition.

Verification for 5.1.5.12.1 to 5.1.5.12.8:

*Visual check, functional test and design check.*

#### **5.1.5.13 Transmission systems**

##### **5.1.5.13.1 General**

**5.1.5.13.1.1** Power driven systems shall be designed and constructed in such a fashion that inadvertent movements of the turntable ladder are prevented.

Chains or belts shall only be used in drives if inadvertent movements of the turntable ladder on break of a chain or a belt are automatically prevented.

**5.1.5.13.1.2** Power limiting systems shall be provided for drives to the turntable ladder if the vehicle power source can provide greater power than is required.

Friction clutches shall not be used as overload protection devices for the raising manoeuvre.

**5.1.5.13.1.3** Manual drive systems shall be designed and constructed such that levers and cranks cannot rebound.

If movements are initiated by more than one drive system, an interlocking device shall prevent two systems from acting simultaneously.

**5.1.5.13.1.4** Each of the following movements shall have more than one drive:

— raising, lowering;

- extending, housing (the winding mechanism is not covered by this requirement);
- levelling of the ladder;
- levelling of the rescue cage.

If a single drive system is used for the slewing movement, the safety factor for breaking shall be at least 4.

**5.1.5.13.1.5** Every multiple load bearing system (e.g. parallel systems) shall be capable at least of holding the least favourable position of the turntable ladder in the event of failure of one element in the system.

The safety factor required for each of the functional elements of the kinematic chain linking the load bearing system and the load shall be at least 2,5 for simple systems and 2,2 for multiple systems (all systems together) against fracture, except the safety factors required in 5.1.5.13.1.4, 5.1.5.13.2 and 5.1.5.13.3.

Verification for 5.1.5.13.1.1 to 5.1.5.13.1.5:

*Visual check, functional test and design check.*

### 5.1.5.13.2 Transmission by cables

#### 5.1.5.13.2.1 Cables

Load bearing cables shall be manufactured from steel with the following characteristics.

The number of wires shall be at least 114.

The following formula shall be used to calculate the cable diameter:

$$d_{\min} = c \times \sqrt{S} \geq 6 \text{ mm} \quad (5)$$

where

- $d_{\min}$  is the minimum diameter of the cable;
- $S$  is the tensile load of the cable determined by calculation in newtons;
- $c$  is the factor determined using Table 7.

**Table 7 — Determination of factor  $c$**

Rated strength of the individual wires in $\text{N/mm}^2$	1 770	1 960	2 160
Factor $c$ in $\frac{\text{mm}}{\sqrt{N}}$	0,08	0,075	0,07

For reasons of stability in cases of differences in temperature, ageing, dilation and ease of detection of defects, it is recommended that load bearing cables be manufactured from galvanized steel.

When using cables as load bearing parts for a ladder set, there shall be at least two independent cable systems, each with their own anchorage. Each independent system can consist of one cable or two or more cables acting in parallel. The safety factor of each system shall be at least 7. The safety factor is the ratio between the minimum breaking load of the cable and the force which may occur in the cable under static conditions with fully loaded turntable ladder.

Where a cable system consists of a number of cables in parallel connected to one point, there shall be a provision for equalizing the loading on the cables.

The machine shall be designed to allow re-tensioning of the cables during maintenance.

The cables shall be protected against corrosion.

Cable terminations shall have a breaking strength of at least 80 % of the minimum breaking load of the cable. Wire cable clamps shall not be used as cable terminations for load bearing cables with the exception of drum fastenings with an appropriate number of safety windings (windings remaining on the drum).

The machine shall be designed to allow the inspection of cables and cable terminations visually without it being necessary to remove the cables and without the necessity for dismantling parts of the turntable ladder other than protective covers and casings.

NOTE Inspection apertures located in appropriate places satisfy this requirement.

#### 5.1.5.13.2.2 Drums, pulleys

Cable drums shall have grooves or devices preventing the cable running off the drum:

- a) grooves in cable drums in case of single layer winding and fixed rope length, or
- b) rim discs of a height exceeding the top lay of cable by 1,5 the cable diameter.

Cables shall only be laid on cable drums in a single layer unless a special cable winding device is provided. In this case only rim discs according to b) are permissible. When the ladder set is at its maximum extending, a safety winding composed of at least two windings of cable shall remain on the drum.

The fastening of the cable, including the safety windings, to drum shall be capable of bearing at least 80 % of the minimum breaking load of the cable.

#### 5.1.5.13.2.3 Calculation of cable winding diameter

The following formula shall be used to calculate the diameter of the cable drums, cable pulleys and compensating rollers:

$$D_{\min} = h_1 \times h_2 \times d_{\min} \tag{6}$$

where

$h_1$  is determined using Table 8;

$h_2$  is determined using Table 9.

**Table 8 — Determination of factor  $h_1$  for the following construction unit**

	Construction unit		
	Cable drum	Cable pulley	Compensating roller
Factor $h_1$	14	16	14

NOTE Factor  $h_2$  given in Table 9 is a function of the maximum number of bending changes  $w$  in the cable per cycle, i.e. during extending and housing of the ladder set.

**Table 9 — Determination of factor  $h_2$  for the following construction unit**

	Construction unit	
	Cable drum	Cable pulley
Factor $h_2$ for $w = 1$ to $5$	1	1,00
Factor $h_2$ for $w = 6$ to $9$	1	1,12
Factor $h_2$ for $w \geq 10$	1	1,25

The winding diameter of the cable is measured relative to the central axis of the cable (see Figure 18).

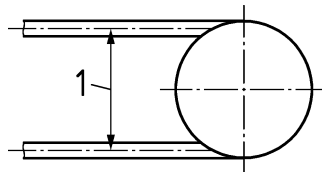

**Key**

1 winding diameter

**Figure 18 — Winding diameter**

Devices shall be provided preventing cables from being unintentionally displaced from the cable pulleys. This requirement shall also apply where the cable is not under load.

The cross-section of the cable grooves in cable drums and cable pulleys shall be circular over an angle of at least 120°.

Verification for 5.1.5.13.2.1 to 5.1.5.13.2.3:

*Visual check, functional test and design check.*

**5.1.5.13.3 Transmission by chains**

**5.1.5.13.3.1 Chains**

When using chains as load bearing parts for a ladder set, there shall be at least two independent chain systems, each with their own anchorage. Each independent system can consist of one chain or two or more chains acting in parallel. The safety factor of each chain system shall be at least 6. The safety factor corresponds to the ratio between the minimum breaking load of the chain and the force which can occur in the chain under static conditions with fully loaded turntable ladder.

Round link steel chains shall not be used.

Where a chain system consists of a number of chains in parallel connected to one point, there shall be a provision for equalizing the loading on the chains.

The machine shall be designed to allow re-tensioning of the chains during maintenance.

Chain fastenings shall have a proved breaking strength of at least 100 % of the minimum breaking load of the chain.

The machine shall be designed to allow the inspection of chains and chain fastenings visually without having to dismantle the chains or without the need for significant dismantling of parts of the turntable ladder.

Suitably arranged visual inspection apertures satisfy this requirement.

#### **5.1.5.13.3.2 Pulleys and pinions**

Pulleys and pinions shall have devices preventing the chain from being unintentionally displaced from pulleys and pinions. This requirement shall also be satisfied when the chain is not loaded.

Verification for 5.1.5.13.3.1 and 5.1.5.13.3.2:

*Visual check, functional test and design check.*

#### **5.1.5.14 Alarms**

Alarms and safety indicating devices including flashing lights on jack booms shall not be capable of being taken out of service whilst the ladder is operating.

Verification:

*Functional test.*

#### **5.1.5.15 Lockers**

Additionally to EN 1846-2, if breathing apparatus sets are provided other than in the cab, they shall be stowed in one or several lockers. The supports shall enable the breathing apparatus sets to be easily donned from a position at ground level or from the place where the operator stands with safety, including when the vehicle is in the working position.

Verification:

*Functional test.*

#### **5.1.5.16 Safety requirements related to electromagnetic phenomena**

The machines shall have sufficient immunity to electromagnetic disturbances to enable them to operate safely as intended and not fail to danger when exposed to the levels and types of disturbances reasonably foreseeable by the manufacturer.

Machines shall be designed so that equipment and sub-assemblies can be installed and wired in accordance with the recommendations of the suppliers of these sub-assemblies.

NOTE General requirements regarding electromagnetic compatibility (for the EEA the EMC Directives) can be covered by the application of European harmonized standards. For example the relevant clauses of either EN 55012 (CISPR 12) for emission, if the equipment includes only internal combustion engines, or by the generic standard EN 61000-6-3 for emission and by EN 61000-6-2 for immunity.

Verification:

*Check of type approval documentation.*

#### **5.1.6 Requirements relating to noise**

##### **5.1.6.1 Noise reduction at source at the design stage**

Machinery shall be so designed and constructed that risks resulting from the emission of airborne noise are reduced to the lowest level.

Technical progress and the availability of means of reducing noise, in particular, at source, should be taken into account.

The success of the applied noise reduction measures is assessed on the bases of the actual noise emission values in relation to other machines of the same family.

The main noise sources present on turntable ladders are:

- chassis;
- hydraulic actuators;
- pump.

When designing a turntable ladder, the available information and technical measures to control noise at source should be taken into account.

Recommended practice for the design of low-noise machinery is given in EN ISO 11688-1. Noise reduction measures apply listed in EN 1846-2:2009+A1:2013, Annex E. Reduction, by adjustment at the design stage, of engine speed during turntable operation is also a measure to reduce noise emission.

NOTE EN ISO 11688-2 gives useful information on noise generation mechanisms in machinery.

The user shall be informed on the residual risk due to noise, see 7.2.2.

#### **5.1.6.2 Noise emission measurement**

For the measurement of the emission sound pressure level at the operator's position and, if necessary, the sound power level, the methods given in EN 1846-2:2009+A1:2013, Annex F shall be used with the following specifications:

- work station to be considered is the main control console;
- no measurement of C-weighted peak sound pressure level is necessary as no impulsive noise is emitted.

## **5.2 Performance requirements**

### **5.2.1 Operational requirements**

#### **5.2.1.1 General**

If devices are permanently installed, their installation shall be in accordance with the requirements and the instructions of the manufacturer of the equipment and of the manufacturer of the chassis.

Dependability management systems are recommended.

NOTE See for example EN 60300-1, EN 60300-2, Military Handbook 217 (MIL-HDBK-217F).

#### **5.2.1.2 Operating time**

For all classes of ladders, the operating time without the fitting of the rescue cage shall be less or equal to 140 s.

When the fitting of the rescue cage is included, the operating time, for all classes of ladders, shall be less than 180 s.

Verification:

*In compliance with Annex B.*

**5.2.1.3 Prevention of interference**

Turntable ladders shall incorporate a mechanism preventing interference with the ladder by the cab, bodywork or jacks in any position.

Verification:

*Functional check.*

**5.2.2 Requirements demanded by national regulations**

The technical requirements for use (e.g. dimensions, weight, rated working height, nominal projection, nominal reach) depend on national constructional regulations (for nominal reaches see Table 10 and Annex C).

**Table 10 — Nominal reaches**

Class	> 30 to 56	30	24	18
nominal reach (in metres)	$h_N / l_N$			
NOTE The known values for the different countries are given in the informative Annex C.				

Verification for nominal reach:

*Support the ladder on a hard and essentially horizontal ground.*

*Position the ladder so that the slewing angle  $\theta$  is equal to  $(90 \pm 3)$ .*

*The jacking width, the mass of the total vehicle minus the driver and the equipment masses and the test load in the rescue cage should be fixed by the manufacturer.*

*Attain the nominal reaches.*

*Carry out a dimensional check (the known values for the different countries are given in informative Annex C).*

**5.2.3 Overall maximum dimensions**

Table 11 gives the overall maximum dimensions of the ladders vehicles in travel position.

**Table 11 — Overall maximum dimensions in travel position**

Class	> 30 to 56	30	24	18
Length	12,0 m	11,0 m	9,5 m	9,5 m
Width	2,55 m	2,55 m	2,55 m	2,5 m
Height	4,0 m	3,3 m	3,3 m	3,3 m

Verification:

*Support the ladder on a hard and essentially horizontal ground.*



*Place the ladder in the travel position.*

*Carry out a dimensional check.*

#### **5.2.4 Maximum gross laden mass**

With respect to maximum gross laden mass of turntable ladders, the following masses given in Table 12 and Table 13 shall apply.

**Table 12 — Maximum gross laden mass**

<b>Class</b>	<b>&gt; 30 to 56</b>	<b>30</b>	<b>24</b>	<b>18</b>
Gross laden mass (GLM)	—	max. 16 000 kg	max. 14 000 kg	max. 13 000 kg

National regulations may apply to the maximum gross laden mass of turntable ladders.

**Table 13 — Masses taken into consideration in the calculation of gross laden mass**

<b>Class</b>	<b>&gt; 30 to 56, 30, 24, 18</b>
Persons	90 kg per person
Equipment	325 kg
Available reserve mass	200 kg

NOTE The available reserve mass enables the additional arrangements or specifications of individual Fire and Rescue Services (e.g. third man in the cab, hose reels, generator).

Verification:

*Carry out load measurements in accordance with the method described in EN 1846-2.*

#### **5.2.5 Radio interference**

The use of the turntable ladder shall not interfere with any communication equipment in use on the incident ground. Radio equipment used by fire brigade, police or other emergency services shall not be affected if they are in use at a distance exceeding 3 m from the turntable ladder (see Figure 19).

Verification:

*Position the ladder set randomly.*

*Position a radio-transmitter and receiver capable of sweeping the entire defined frequency range at maximum power at each control console.*

*Manoeuvre the ladder set in conditions that are representative for all possibilities of the functioning, during which time the transmitter and receiver shall be operated throughout the entire frequency band at maximum power.*

*Carry out the test for a minimum of 10 min.*

*Repeat the test using different relative positions for the transmitter and receiver. Test at least four positions.*

*Verify that the quality of acoustic transmission is such as to permit the comprehension of simple dialogue (80 % of a series of transmitted phrases shall be repeated by the receiver).*

Dimensions in metres

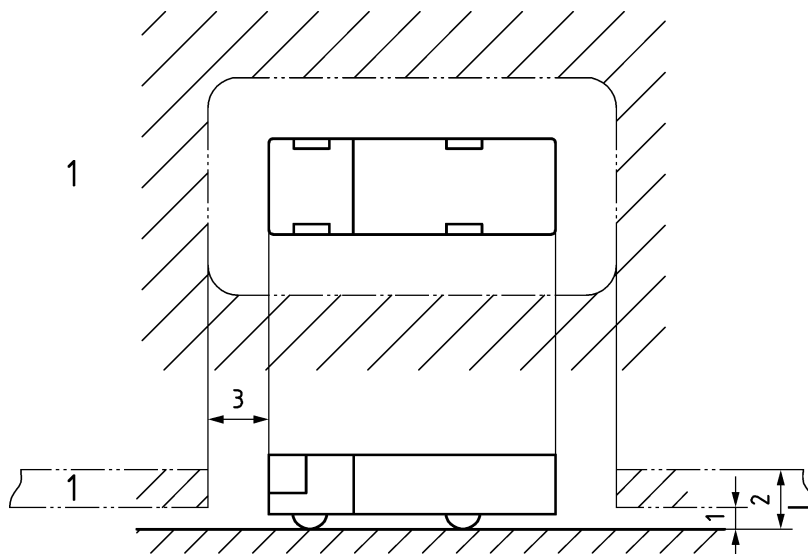

**Key**  
 1 unaffected zone

**Figure 19 — Diagram of minimum unaffected zones**

## 6 Designation

Turntable ladders with combined movements shall be designated as follows:

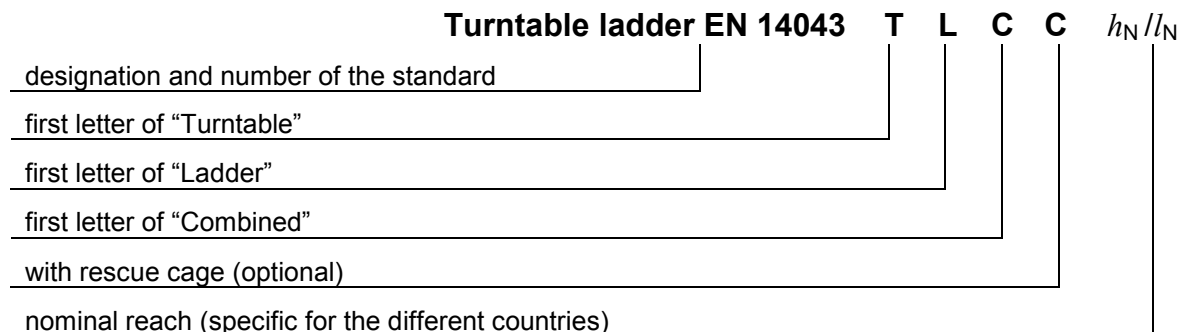

**NOTE** The class (see Annex C) is determined by one of the following numbers: 18, 24, 30, > 30 to 56, which would correspond to the maximum rescue height or the value immediately below the maximum rescue height.

**EXAMPLE** Turntable ladder EN 14043 TLCC 26/10 for a turntable ladder with combined movements with rescue cage in the class 30;

German: Drehleiter EN 14043 DLAK 23/12;

French: Échelle pivotante EN 14043 EPCP 28/10.

## 7 Information for use

### 7.1 General

In addition to compliance with this clause, information for use, related to safety, shall comply with EN ISO 12100:2010, 6.4.

## 7.2 Instruction handbook

### 7.2.1 General

The instruction handbook shall conform to this clause and EN ISO 12100:2010, 6.4.5.

Instruction for maintenance operations which are to be carried out only by specialist maintenance personnel shall be separated from the other instructions.

The instruction handbook shall indicate that any modifications by the user shall only be carried out with the ladder manufacturer's approval.

The instructions for use (information for users) shall comply with EN 1846-2:2009+A1:2013, Clause 6 and satisfy the requirements of Clause 5 of this European Standard which refer to this clause.

The instruction handbook shall state the periodic inspections considered necessary by the manufacturer.

National regulations may apply to periodic inspection.

The instruction handbook shall include the specific information as specified in 7.2.2 to 7.2.9.

### 7.2.2 Operating instruction

Operating instructions shall give detailed information necessary for safe use, in particular:

- a) importance of operation only by trained operators;
- b) responsibilities of operators;
- c) characteristics, description and intended use of the ladder;
- d) location, purpose and use of all normal controls, emergency operation and any emergency stop controls;
- e) information about setting up the ladder, correct use of jacks and suspension locking, operation on sloping ground, limitations of full operation on excessive slopes, the use of wheel chocks on steep slopes, the necessary bearing strength of the ground, maximum ground loads applied by the wheels and stabilizing jacks of the vehicle, guidelines for assessing adequacy of the ground, e.g. by driving the wheels of the vehicle over potentially soft ground, checking for pot-holes and underground cavities;
- f) avoidance of overloading in the rescue cage and/or the ladder set;
- g) minimum periodical checks defined by the manufacturer on the safe condition of the machine, oil leaks, loose electrical fitting/connections, chafed hoses/cables, condition of tyres/brakes/batteries, collision damage, obscured instruction plates, special safety devices, etc.;
- h) avoidance of contact of the ladder set with the vehicle cab, other fixed objects (buildings, etc.), moving objects (vehicles, cranes, etc.) and live electrical conductors;
- i) prohibition of any increase in reach or working height by use of additional equipment (e.g. ladders);
- j) prohibition of any addition that would increase loads and wind loading on the ladder;
- k) environmental limitations, use in snow and ice and with wind exceeding 12,5 m/s unless additional precautions are taken (e.g. guy lines);
- l) information concerning vibrations transmitted by the machinery to the hand-arm system and to the whole body;

- 1) the vibration total value to which the hand-arm system is subjected, if it exceeds  $2,5 \text{ m/s}^2$ . Where this value does not exceed  $2,5 \text{ m/s}^2$ , this shall be mentioned;

The magnitude of hand-arm vibration when using permanently installed equipment of fire rescue service vehicles is in general significantly below  $2,5 \text{ m/s}^2$ . In this case it is sufficient to mention that the acceleration is below this limit;

- 2) the highest root mean square value of weighted acceleration to which the whole body is subjected, if it exceeds  $0,5 \text{ m/s}^2$ . Where this value does not exceed  $0,5 \text{ m/s}^2$ , this shall be mentioned. The particular operating conditions of the machine relevant to the determination of this single value shall be indicated;
- 3) the uncertainty of measurement (whenever vibration values are indicated).

The values indicated shall be either those actually measured for the machinery in question or those established on the basis of measurements taken for technically comparable machinery which is representative of the machinery to be produced. The vibration shall be measured using the most appropriate measurement code for the machinery concerned and the operating conditions during measurement and the measurement codes used shall be described.

NOTE This single whole-body emission value is determined under particular operating and terrain conditions and is therefore not representative for the various conditions in accordance with the intended use of the machine. Consequently this single whole-body vibration emission value declared by the manufacturer in accordance with this European Standard is not intended to determine the whole-body vibration exposure of the operator using this machine.

- m) working conditions in which the use of personal protection equipment is recommended;
- n) procedures for frequent checks on the proper functioning of automatic safety devices;
- o) hazards arising from leaving machines raised and unattended for long periods, due to movement caused by internal hydraulic/pneumatic leakage;
- p) main control stand should be manned continuously during ladder operation;
- q) precautions if travelling in transport position;
- r) information on noise emission values (noise emission declaration) obtained using the noise test code in EN 1846-2:2009+A1:2013, Annex F;
- s) information concerning the radiation emitted for the operator and exposed persons where machinery is likely to emit non-ionizing radiation which can cause harm to persons, in particular persons with active or non-active implantable medical devices.

### 7.2.3 Transport, handling and storage information

- a) Any special provisions for securing parts of the ladder during travel;
- b) method of loading onto other vehicles/vessels for transport, including lifting points, weight, centre of gravity, etc., for lifting purposes;
- c) precautions to be taken before periods of storage indoors or outdoors;
- d) checks to be made prior to use after periods of storage, exposure to extremes of ambient conditions - heat, cold, moisture, dust, etc.

#### **7.2.4 Information on commissioning**

- a) Checks to be made on power supply, hydraulic fluids, lubricants, etc. on first use, after long periods of storage or changes in environmental conditions (winter, summer, changed geographical location, etc.);
- b) test to be carried out before first use;
- c) test report, where appropriate, detailing the static and dynamic tests carried out by or for the manufacturer or manufacturer's authorized representative.

#### **7.2.5 Machine details**

- a) Principal operation features. Description, with diagrams when appropriate, of:
  - 1) power source;
  - 2) power circuits;
  - 3) control circuits;
  - 4) actuators;
  - 5) purpose, location and function of automatic safety devices;
- b) areas of use;
- c) if the rescue cage is not made of steel or aluminium, information on the constituent material shall be provided.

#### **7.2.6 Maximum loads in the rescue cage and/or on the ladder set**

- a) Maximum rated load;
- b) maximum manual force in newtons;
- c) maximum wind speed in metres per second.

#### **7.2.7 Maintenance information for use by trained personnel**

- a) Technical information including electrical/hydraulic/pneumatic circuit diagrams;
- b) consumable items necessitating regular checks (lubricants, hydraulic fluid level, batteries, etc.);
- c) safety features to be checked at specified intervals including safety devices, load holding actuators, emergency stops, etc.;
- d) measures to be taken to ensure safety during maintenance;
- e) checking structural and load-supporting components for any dangerous deterioration (corrosion, cracking, abrasion, etc.);
- f) criteria for repair/replacement of parts, e.g. wire ropes and chains and the specifications of the spare parts to be used, when these affect the health and safety of operations;
- g) importance of using only manufacturer approved replacement parts, particularly for load-supporting and safety-related components;

- h) importance of obtaining manufacturer's approval of any alteration which might affect stability, strength or performance;
- i) parts necessitating adjustment, including setting details;
- j) any necessary tests/checks after maintenance to ensure a safe operating condition;
- k) precautions to be taken when servicing machines fitted with pressure accumulators;
- l) indications as to which operations require the request of additional information from the manufacturer.

### 7.2.8 Special working methods or conditions

The instruction for use should recommend to the user to obtain the guidance and approval of the manufacturer for any special working methods or conditions which are outside those intended by the manufacturer (see 7.2.2.a).

### 7.2.9 Periodical examinations and tests

**7.2.9.1** The information provided in the instruction handbook shall include, as a minimum, the following information about the required periodic examinations and testing in use:

- visual examination of the structure with special attention to corrosion and other damage of load bearing parts including welds;
- examination of the mechanical, hydraulic, pneumatic and electrical systems with special attention to safety devices;
- test to prove the effectiveness of brakes and/or overload devices;
- function tests of ladder performance.

**7.2.9.2** Information shall be given that the frequency and extent of periodical examinations and tests depends on national regulations, manufacturer's instructions, operating conditions and the frequency of use.

A note shall be given that it is normally not necessary to dismantle parts at periodical examinations, unless there are any doubts in relation to reliability and safety. The removal of covers, the exposure of observation apertures and bringing the ladder to the transport position are not considered to be dismantling.

## 7.3 Marking

**7.3.1** One or more durable manufacturer's plate(s) giving the following indelible information shall be permanently attached to the ladder in an easily visible location:

- the business name and full address of the manufacturer and, where applicable, manufacturer's authorized representative;
- mandatory marking<sup>1)</sup>;
- country of manufacture;
- designation of series or type;
- designation of the machinery;

---

1) For machines and their related products intended to be put on the market in the EEA, CE marking as defined in the applicable European Directive(s), e.g. Machinery, when the machine complies fully with all relevant Directives.

- serial or identification number;
- rating information (mandatory for electrotechnical products: voltage, frequency, power, etc.);
- the year of construction, that is the year in which the manufacturing process is completed;
- maximum permitted wind speed in m/s;
- maximum permitted slope of the supporting surface;
- hydraulic supply information if an external hydraulic power supply is used;
- pneumatic supply information if an external pneumatic power supply is used;
- electrical supply information if an external electric power supply is used;
- operating instructions for the emergency operation system;
- nominal power expressed in kilowatts (kW);
- mass of the most usual configuration, in kilograms (kg).

Parts of this information may be repeated at other appropriate places on the ladder (see 7.3.3).

**7.3.2** The following information shall be permanently and clearly marked on each rescue cage in a visible place:

- rated load in kilograms including, if applicable, the effects of additional loads and forces;
- rated load given as permitted number of persons and mass of equipment in kilograms;
- maximum permitted manual force in newtons;
- maximum permitted wind speed in metres per second;
- permitted special loads and forces, if applicable;
- warning label, at least easily and judiciously affixed in the rescue cage, shall indicate the number of persons permissible according to the surface and the maximum load ( $P_L = P_N + P_Z$ ) given by the manufacturer (see example given in Figure 20).

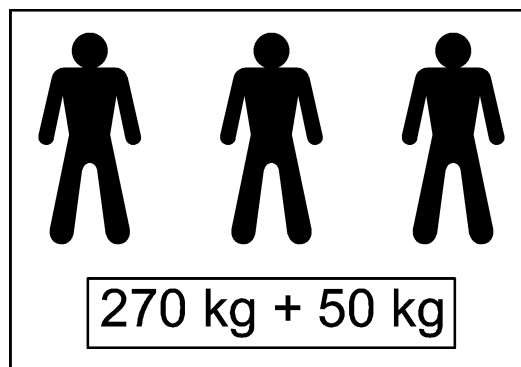

**Figure 20** — Example of a warning label for the number of person permissible in the rescue cage

**7.3.3** Points of connection of external power supplies shall be permanently and clearly marked with the essential power supply information (see 7.3.1).

**7.3.4** Hydraulic fluid power systems with accumulators shall have a warning label:

**“Caution — Depressurize system before maintenance”.**

**7.3.5** If anchoring points to allow the use of a pulley block appliance set for rescue from heights are mounted at the top of the upper ladder section and at the bottom of the slew ring, such anchoring points shall be permanently and clearly marked with the maximum permissible static load of each anchoring point.

Anchoring points or structures for the allowed number of persons in the cage for attachment of personal protective equipment shall be marked (see 5.1.5.4.3).



## Annex A (informative)

### Example of table recording the stability tests

Table A.1 — Example of table recording the stability tests

Verification					Static test				Dynamic test	
Subclause					5.1.2.2.1	5.1.2.2.1	5.1.2.3.2		5.1.2.2.1	5.1.2.2.2
Stabilization	Width	Rescue cage	Maximum working load	Test load	Angle of elevation	Rescue height	Projection		Residual force	Minimum residual force
	m		$P_L$	$P_P$	$\alpha$	$h$	measured	Display difference	$F_R$	$F_R > 0$
				kg / N	°	m	m	±4 %	kg	kg
Minimum or fixed width		Without	Without							
			1 pers.							
		With	1 pers.							
			2 pers.							
			3 pers.							
Maximum width		Without	Without							
			1 pers.							
		With	1 pers.							
			2 pers.							
			3 pers.							

**Annex B**  
(normative)

**Operating time**

The operating time shall be determined according to Table B.1.

**Table B.1 — Determination of the operating time**

<b>Ladder with fitted rescue cage</b>	<b>Ladder with detached rescue cage located separately which is still to be fixed</b>	
	<b>Procedure</b>	<b>Parallel procedure</b>
<p>Only one operator</p> <p>Start stopwatch</p> <ul style="list-style-type: none"> <li>• Engage the movement</li> <li>• Go to the jacking control console</li> <li>• Order the maximum stabilization</li> <li>• Go to the main control console</li> <li>• Take the ladder out of the travel position</li> <li>• Slew to 90° and both raise and extend to maximum length</li> </ul> <p>Stop stopwatch.</p>	<p>Only one operator</p> <p>Start stopwatch</p> <ul style="list-style-type: none"> <li>• Engage the movement</li> <li>• Go to the jacking control console</li> <li>• Order the maximum stabilization</li> <li>• Go to the main control console</li> <li>• Take the ladder out of the travel position and put it in position for attaching the rescue cage</li> </ul> <p>Stop stopwatch.</p>	<p>Number of operators indicated in the instructions for use shall be considered</p> <ul style="list-style-type: none"> <li>• Take the rescue cage out of its storing position and bring it up to the point of implementation on the ladder (positioning point) (take into account the height of removal from storage position and the transported weight/persons)</li> <li>• Attach the rescue cage</li> <li>• Slew to 90° and both raise and extend to the maximum length</li> </ul> <p>Stop stopwatch.</p>

**Annex C**  
(informative)

**List of nominal reaches in several European countries applicable to  
turntable ladders**

The known values of the nominal reaches of turntable ladders in several European countries are given for information in Table C.1.

**Table C.1 — Nominal reaches of turntable ladders in several European countries**

Country	Class			
	> 30 to 56	30	24	18
Nominal reaches				
Austria		23/12	18/12	12/9
Belgium				
Bulgaria				
Cyprus				
Croatia				
Czech Republic				
Denmark				
Estonia				
Finland				
France		28/10	23,5/6	18/3,3
Germany		23/12	18/12	12/9
Greece				
Hungary				
Iceland				
Ireland				
Italy				
Latvia				
Lithuania				
Luxembourg				
Malta				
The Netherlands				
Norway				
Poland				
Portugal				
Romania				

<b>Slovakia</b>				
<b>Slovenia</b>				
<b>Spain</b>				
<b>Sweden</b>				
<b>Switzerland</b>				
<b>The Former Yugoslav Republic of Macedonia</b>				
<b>Turkey</b>				
<b>United Kingdom</b>				

## Annex D (informative)

### Verification and reception tests

The verifications and the reception tests stated in the instruction handbook and planned by the manufacturer should be in compliance with Table D.1.

**Table D.1— Verifications and reception tests**

Number of the subclause – Verification with short description of requirement/test	Type Test	Test of fitness for purpose / use (reception test)
5.1.2.1 (Calculation)	X	
5.1.2.2.1 (Static stability)	X	X
5.1.2.2.2 (Dynamic stability)	X	X
5.1.2.3.1 (Limit switches)	X	X
5.1.2.3.2 (Stopping devices - Free-standing boundary)	X	X
5.1.2.3.3 (Stability monitoring device to detect the resultant overturning moment)	X	X
5.1.2.3.4 (Emergency drive system)	X	X
5.1.2.3.5 (Failure of the normal control system)	X	X
5.1.2.3.6 (Safety systems remain energized when ladder is not in transport or travel position)	X	
5.1.3.2 (Strength - At boundary of free-standing use with $\alpha_{max}$ )	X	X
5.1.3.3 (Strength - At supported boundary)	X	
5.1.4.1 (Fitness - Proper operations of all functions)	X	X
5.1.4.2 (Fitness - Maintain of position ladder loaded to 90 kg)	X	X
5.1.5.1 (Function - Power transmission)	X	X
5.1.5.2.1 (Function - Systems preventing operation without fully or partially locked suspension)	X	X
5.1.5.2.2 (Function - Interlocking of power supplies to jacking system and ladder set moving system)	X	X
5.1.5.2.3 (Function - Device preventing operation until jacking system is in position)	X	X
5.1.5.2.4 (Function - Powered jacking systems - Device preventing movements of jacking system unless ladder set is in transport position)	X	X
5.1.5.2.5 (Function - Unintentional movements of jacking equipment and suspension locking systems)	X	X
5.1.5.2.6 (Function - Slip test while jacked or while being stabilized on maximum permitted gradient)	X	

Number of the subclause – Verification with short description of requirement/test	Type Test	Test of fitness for purpose / use (reception test)
5.1.5.2.7 (Function - Compensation for local unevenness of the ground up to at least 15°.)	X	
5.1.5.2.8 (Function - Compensate for depressions up to 50 mm without using blocks)	X	
5.1.5.2.9 (Function - Accommodation of bumps up to 150 mm without affecting stability)	X	
5.1.5.2.10 (Function - Electrically conducting connection of jacks)	X	
5.1.5.2.11 (Function - Jacks - Suitable warning colours and warning flashing lights at their extremities)	X	X
5.1.5.2.12 (Function - Baseplate pressure not exceeding 80 N/cm <sup>2</sup> )	X	X
5.1.5.2.13 (Function - Dimensions of blocks)	X	X
5.1.5.2.14 (Function - Prevention of foot under jack baseplate)	X	X
5.1.5.2.15 (Function - Audible warning signal relating jacks movement and suspension locking mechanism)	X	X
5.1.5.2.16 (Function - Suspension locking device)	X	
5.1.5.2.17 (Static tilt angle)	X	
5.1.5.3.1 (Levelling - Automatic levelling devices to ensure that rungs and base of rescue cage are horizontal)	X	X
5.1.5.3.2 (Levelling - Warning lamp in case of switched off levelling device)	X	
5.1.5.3.3 (Levelling - Device which automatically stops excessive levelling and other aggravating movement)	X	X
5.1.5.3.4 (Levelling - Angle between last ladder section and horizontal (max. 77°))	X	X
5.1.5.4.1 (Rescue cage - Levelling correction system if load bearing components fail)	X	
5.1.5.4.2 (Rescue cage - Levelling correction system - Maximum permissible deviation ± 3°)	X	X
5.1.5.4.3 (Rescue cage - Handrail, guard-rail, anchoring points)	X	
5.1.5.4.4 (Rescue cage - Door opening and locking devices)	X	
5.1.5.4.5 (Rescue cage - Slip-resistant base surface)	X	
5.1.5.4.6 (Rescue cage - Removable cage)	X	X
5.1.5.4.7 (Rescue cage - Cage mounting device)	X	
5.1.5.4.8 (Rescue cage – Crushing or shearing between the rescue cage and ladder)	X	
5.1.5.4.9 (Rescue cage - Transfer between rescue cage and turntable ladder)	X	
5.1.5.4.10 (Rescue cage - Width and height of access openings)	X	
5.1.5.4.11 (Rescue cage - Accessories fastened in place by mechanical locking)	X	X

Number of the subclause – Verification with short description of requirement/test	Type Test	Test of fitness for purpose / use (reception test)
5.1.5.4.12 (Rescue cage - Working light)	X	
5.1.5.4.13 (Rescue cage - Useable area <i>A</i> of rescue cage and number of persons permitted in the rescue cage <i>N</i> )	X	
5.1.5.4.14 (Rescue cage - Stopping of all aggravating movements on sustaining impact)	X	X
5.1.5.5.1 (Control and function control consoles - General)	X	
5.1.5.5.2 (Control and function control consoles - Jacking control console(s))	X	
5.1.5.5.3 (Control and function control consoles - Main control console)	X	
5.1.5.5.4 (Control and function control consoles - Rescue cage deployment control console(s))	X	
5.1.5.5.5 (Control and function control consoles - Rescue cage control console)	X	X
5.1.5.5.6 (Control and function control consoles - Illumination of the operating area)	X	X
5.1.5.5.7 (Control and function control consoles - Additional functions)	X	
5.1.5.6 (Guy lines)	X	X
5.1.5.7.1 (Cradle/turret - Protective device to prevent risks arising from crushing, shearing or contact)	X	
5.1.5.7.2 (Cradle/turret - Position indicated by flashing lights)	X	
5.1.5.7.3 (Cradle/turret - Lubricating)	X	
5.1.5.8.1 (Ladder set - Lighting equipment)	X	
5.1.5.8.2 (Ladder set - Chain and cable drums - Trapping)	X	X
5.1.5.8.3 (Ladder set - Access to ladder set from chassis deck)	X	
5.1.5.8.4 (Ladder set - Voice communication system)	X	X
5.1.5.8.5 (Ladder set - Rung alignment)	X	X
5.1.5.9 (Hydraulic circuit)	X	X
5.1.5.10 (Electrical circuit)	X	X
5.1.5.11.1 (Chassis deck/Walkways/Access - Slip-resistance)	X	
5.1.5.11.2 (Chassis deck/Walkways/Access - Access from the ground by at least two points.)	X	
5.1.5.11.3 (Chassis deck/Walkways/Access - Free of obstacles)	X	
5.1.5.11.4 (Chassis deck/Walkways/Access - Ladder rung protective covering)	X	
5.1.5.11.5 (Chassis deck/Walkways/Access - Ladder dimensions)	X	
5.1.5.11.6 (Chassis deck/Walkways/Access - Mount to and alight from vehicle deck, main control console and ladder)	X	
5.1.5.12 (Monitoring/Controlling/Regulating software)	X	

Number of the subclause – Verification with short description of requirement/test	Type Test	Test of fitness for purpose / use (reception test)
5.1.5.13.1 (Transmission systems - General)	X	
5.1.5.13.2 (Transmission systems - Transmission by cables)	X	
5.1.5.13.3 (Transmission systems - Transmission by chains)	X	
5.1.5.14 (Alarms)	X	X
5.1.5.15 (Lockers)	X	
5.1.5.16 (Electromagnetic phenomena)	X	X
5.2.1.1 (Operational requirements - General)	X	X
5.2.1.2 (Operational requirements - Operating time)	X	X
5.2.1.3 (Operational requirements - Prevention of interference)	X	X
5.2.2 (Operational requirements - National regulations)	X	X
5.2.3 (Overall maximum dimensions)	X	
5.2.4 (Maximum gross laden mass (GLM) and other masses)	X	
5.2.5 (Radio disturbances)	X	



## **Annex ZA** (informative)

### **Relationship between this European Standard and the Essential Requirements of EU Directive 2006/42/EC**

This European Standard has been prepared under a mandate given to CEN by the European Commission and the European Free Trade Association to provide a means of conforming to Essential Requirements of the New Approach Directive 2006/42/EC on machinery.

Once this standard is cited in the Official Journal of the European Union under that Directive and has been implemented as a national standard in at least one Member State, compliance with the normative clauses of this standard, except 5.1.4, 5.2, Clause 6 and 7.2.9 confers, within the limits of the scope of this standard, a presumption of conformity with the relevant Essential Requirements of that Directive and associated EFTA regulations.

Compliance with EN 14043 and the relevant normative clauses of EN 1846-1, EN 1846-2 and EN 1846-3 are required to comply with the Essential Requirements as indicated in this Annex and achieve presumption of conformity.

**WARNING** — Other requirements and other EU Directives may be applicable to the product(s) falling within the scope of this standard.

## Bibliography

- [1] EN 1777, *Hydraulic platforms (HPs) for fire fighting and rescue services - Safety requirements and testing*
- [2] EN 13001-3-1:2012+A1:2013, *Cranes - General Design - Part 3-1: Limit States and proof competence of steel structure*
- [3] EN 55012, *Vehicles, boats and internal combustion engines - Radio disturbance characteristics - Limits and methods of measurement for the protection of off-board receivers (CISPR 12)*
- [4] EN 60300-1, *Dependability management - Part 1: Dependability management systems (IEC 60300-1)*
- [5] EN 60300-2, *Dependability management - Part 2: Guidelines for dependability management (IEC 61300-2)*
- [6] EN 61000-6-2, *Electromagnetic compatibility (EMC) - Part 6-2: Generic standards - Immunity for industrial environments (IEC 61000-6-2)*
- [7] EN 61000-6-3, *Electromagnetic compatibility (EMC) - Part 6-3: Generic standards - Emission standard for residential, commercial and light-industrial environments (IEC 61000-6-3)*
- [8] EN ISO 11688-1, *Acoustics - Recommended practice for the design of low-noise machinery and equipment - Part 1: Planning (ISO/TR 11688-1)*
- [9] EN ISO 11688-2, *Acoustics - Recommended practice for the design of low-noise machinery and equipment - Part 2: Introduction to the physics of low-noise design (ISO/TR 11688-2)*
- [10] ISO 4302, *Cranes - Wind load assessment*
- [11] MIL-HDBK-217F, *Reliability Prediction of Electronic Equipment<sup>2)</sup>*

---

2) Published by United States Department of Defense and marked with "DISTRIBUTION STATEMENT A: Approved for public release; distribution unlimited.". The document can be downloaded for example from the internet homepage of US-Society of Reliability Engineers (SRE) [www.sre.org](http://www.sre.org).



# British Standards Institution (BSI)

BSI is the national body responsible for preparing British Standards and other standards-related publications, information and services.

BSI is incorporated by Royal Charter. British Standards and other standardization products are published by BSI Standards Limited.

## About us

We bring together business, industry, government, consumers, innovators and others to shape their combined experience and expertise into standards-based solutions.

The knowledge embodied in our standards has been carefully assembled in a dependable format and refined through our open consultation process. Organizations of all sizes and across all sectors choose standards to help them achieve their goals.

## Information on standards

We can provide you with the knowledge that your organization needs to succeed. Find out more about British Standards by visiting our website at [bsigroup.com/standards](http://bsigroup.com/standards) or contacting our Customer Services team or Knowledge Centre.

## Buying standards

You can buy and download PDF versions of BSI publications, including British and adopted European and international standards, through our website at [bsigroup.com/shop](http://bsigroup.com/shop), where hard copies can also be purchased.

If you need international and foreign standards from other Standards Development Organizations, hard copies can be ordered from our Customer Services team.

## Subscriptions

Our range of subscription services are designed to make using standards easier for you. For further information on our subscription products go to [bsigroup.com/subscriptions](http://bsigroup.com/subscriptions).

With **British Standards Online (BSOL)** you'll have instant access to over 55,000 British and adopted European and international standards from your desktop. It's available 24/7 and is refreshed daily so you'll always be up to date.

You can keep in touch with standards developments and receive substantial discounts on the purchase price of standards, both in single copy and subscription format, by becoming a **BSI Subscribing Member**.

**PLUS** is an updating service exclusive to BSI Subscribing Members. You will automatically receive the latest hard copy of your standards when they're revised or replaced.

To find out more about becoming a BSI Subscribing Member and the benefits of membership, please visit [bsigroup.com/shop](http://bsigroup.com/shop).

With a **Multi-User Network Licence (MUNL)** you are able to host standards publications on your intranet. Licences can cover as few or as many users as you wish. With updates supplied as soon as they're available, you can be sure your documentation is current. For further information, email [bsmusales@bsigroup.com](mailto:bsmusales@bsigroup.com).

## BSI Group Headquarters

389 Chiswick High Road London W4 4AL UK

## Revisions

Our British Standards and other publications are updated by amendment or revision.

We continually improve the quality of our products and services to benefit your business. If you find an inaccuracy or ambiguity within a British Standard or other BSI publication please inform the Knowledge Centre.

## Copyright

All the data, software and documentation set out in all British Standards and other BSI publications are the property of and copyrighted by BSI, or some person or entity that owns copyright in the information used (such as the international standardization bodies) and has formally licensed such information to BSI for commercial publication and use. Except as permitted under the Copyright, Designs and Patents Act 1988 no extract may be reproduced, stored in a retrieval system or transmitted in any form or by any means – electronic, photocopying, recording or otherwise – without prior written permission from BSI. Details and advice can be obtained from the Copyright & Licensing Department.

## Useful Contacts:

### Customer Services

**Tel:** +44 845 086 9001

**Email (orders):** [orders@bsigroup.com](mailto:orders@bsigroup.com)

**Email (enquiries):** [cservices@bsigroup.com](mailto:cservices@bsigroup.com)

### Subscriptions

**Tel:** +44 845 086 9001

**Email:** [subscriptions@bsigroup.com](mailto:subscriptions@bsigroup.com)

### Knowledge Centre

**Tel:** +44 20 8996 7004

**Email:** [knowledgecentre@bsigroup.com](mailto:knowledgecentre@bsigroup.com)

### Copyright & Licensing

**Tel:** +44 20 8996 7070

**Email:** [copyright@bsigroup.com](mailto:copyright@bsigroup.com)



...making excellence a habit.™