

BS EN 13964:2014

Incorporating corrigendum May 2014



BSI Standards Publication

Suspended ceilings — Requirements and test methods

bsi.

...making excellence a habit.™

National foreword

This British Standard is the UK implementation of EN 13964:2014. It supersedes BS EN 13964:2004+A1:2006 which will be withdrawn on 31 December 2015.

The UK participation in its preparation was entrusted to Technical Committee B/548, Suspended ceilings.

A list of organizations represented on this committee can be obtained on request to its secretary.

This publication does not purport to include all the necessary provisions of a contract. Users are responsible for its correct application.

© The British Standards Institution 2014.
Published by BSI Standards Limited 2014

ISBN 978 0 580 86418 6

ICS 91.060.30

Compliance with a British Standard cannot confer immunity from legal obligations.

This British Standard was published under the authority of the Standards Policy and Strategy Committee on 31 March 2014.

Amendments/corrigenda issued since publication

Date	Text affected
31 May 2014	Correction to supersession details in national foreword

ICS 91.060.30

English Version

Suspended ceilings - Requirements and test methods

Plafonds suspendus - Exigences et méthodes d'essai

Unterdecken - Anforderungen und Prüfverfahren

This European Standard was approved by CEN on 29 August 2013.

CEN members are bound to comply with the CEN/CENELEC Internal Regulations which stipulate the conditions for giving this European Standard the status of a national standard without any alteration. Up-to-date lists and bibliographical references concerning such national standards may be obtained on application to the CEN-CENELEC Management Centre or to any CEN member.

This European Standard exists in three official versions (English, French, German). A version in any other language made by translation under the responsibility of a CEN member into its own language and notified to the CEN-CENELEC Management Centre has the same status as the official versions.

CEN members are the national standards bodies of Austria, Belgium, Bulgaria, Croatia, Cyprus, Czech Republic, Denmark, Estonia, Finland, Former Yugoslav Republic of Macedonia, France, Germany, Greece, Hungary, Iceland, Ireland, Italy, Latvia, Lithuania, Luxembourg, Malta, Netherlands, Norway, Poland, Portugal, Romania, Slovakia, Slovenia, Spain, Sweden, Switzerland, Turkey and United Kingdom.

EUROPEAN COMMITTEE FOR STANDARDIZATION
COMITÉ EUROPÉEN DE NORMALISATION
EUROPÄISCHES KOMITEE FÜR NORMUNG**CEN-CENELEC Management Centre: Avenue Marnix 17, B-1000 Brussels**

Contents

Page

Foreword.....	6
Introduction	7
1 Scope	8
2 Normative references	9
3 Terms and definitions	12
3.1 General.....	12
3.2 Suspended ceiling and substructure components (see Figure 1)	13
3.2.1 General.....	13
3.2.2 Fixing, connections and supports	14
3.3 Ceiling membranes and ceiling membrane components.....	14
3.4 Typical suspended ceiling systems using volume or thin gauge materials	16
4 Requirements	20
4.1 Dimensions and tolerances – General	20
4.2 Modular dimensions	20
4.3 Mechanical resistance and stability of load bearing components	29
4.3.1 General.....	29
4.3.2 Substructure.....	29
4.3.3 Suspension components and fasteners	31
4.3.4 Resistance to fixings	31
4.3.5 Wind load resistance	31
4.3.6 Impact resistance.....	31
4.3.7 Seismic resistance	31
4.4 Safety in case of fire.....	32
4.4.1 Fire resistance.....	32
4.4.2 Reaction to fire.....	32
4.5 Hygiene, health and environment – Toxic gases and dangerous substances	33
4.5.1 Release of Asbestos (content)	33
4.5.2 Release and/or content of formaldehyde	34
4.5.3 Other dangerous substances	34
4.5.4 Susceptibility to the growth of harmful micro-organisms	34
4.6 Safety in use.....	34
4.6.1 Shatter properties	34
4.6.2 Flexural tensile strength	35
4.6.3 Mechanical strength, safety against failure – baffles	35
4.6.4 Electrical safety.....	35
4.7 Acoustics	35
4.7.1 Test specimen preparation	35
4.7.2 Sound absorption	35
4.7.3 Sound insulation	36
4.7.4 Direct field of application	36
4.8 Durability	36
4.8.1 General.....	36
4.8.2 Dampness	36
4.8.3 Service life requirements	37
4.8.4 Classification of ceiling exposure conditions	37
4.8.5 Corrosion protection	37
4.8.6 Contact corrosion protection	38
4.8.7 Durability of non-cellular PVC profiles	38
4.8.8 Durability of wooden products.....	39
4.9 Colour, light reflectance and gloss factor for suspended ceiling components.....	39
4.9.1 General.....	39

4.9.2	Measurement method of colour composition	39
4.9.3	Measurement method for light reflectance.....	39
4.9.4	Measurement and value of gloss factor.....	39
4.10	Thermal insulation.....	39
5	Loading capacity of substructures components – Test methods.....	39
5.1	General	39
5.2	Bending test of metal substructure profiles.....	40
5.2.1	General	40
5.2.2	Procedure for testing	40
5.2.3	Assessment of results	41
5.2.4	Test report.....	42
5.3	Testing of metal suspension and connecting components.....	43
5.3.1	General	43
5.3.2	Static test.....	47
5.3.3	Functional test.....	48
5.3.4	Assessment of test results (static test)	48
5.3.5	Test report.....	48
5.4	Acceptance factor k_g	49
6	Evaluation of conformity	50
6.1	General	50
6.2	Initial type testing	50
6.3	Factory production control (FPC).....	51
6.3.1	General	51
6.3.2	General requirements	51
6.3.3	Product specific requirements.....	51
6.3.4	Initial inspection of factory and of FPC.....	55
6.3.5	Continuous surveillance of FPC	56
6.3.6	Procedure for modifications.....	56
7	Marking, labelling and packaging.....	56
7.1	Marking and labelling.....	56
7.2	Packaging.....	56
8	Technical documentation	56
Annex A	(informative) Guidance for installation.....	57
A.1	Introduction.....	57
A.2	Manufacturer’s instructions	57
A.3	Site conditions	58
A.4	Supply and storage of materials.....	58
A.5	Measurement and maximum deviations	58
A.5.1	Level mark.....	58
A.5.2	Flatness	58
A.5.3	Squareness	58
A.5.4	Alignment of linear components	58
A.5.5	Cut to size membrane components.....	58
A.5.6	Fire resistant ceilings.....	59
A.5.7	Top fixing and perimeter trim fixing	59
A.6	Mechanical resistance and stability of load bearing components.....	59
Annex B	(informative) Selection of top fixing and perimeter trim fixing.....	61
Annex C	(informative) Wind load resistance.....	63
Annex D	(normative) Impact resistance	64
D.1	Scope.....	64
D.2	Definitions	64
D.3	Test apparatus	64
D.3.1	Balls	64
D.3.2	Ball gun.....	64
D.4	Mounting of structural elements.....	65

D.5	Test procedure	65
D.5.1	General.....	65
D.5.2	Calibration of the ball gun apparatus	66
D.5.3	Testing of ceiling elements.....	66
D.6	Evaluation.....	66
D.7	Test report	66
Annex E (normative) Formaldehyde classes and associated test methods.....		68
Annex F (normative) Membrane components – Flexural tensile strength test		70
F.1	General.....	70
F.2	Test equipment	70
F.2.1	General.....	70
F.2.2	Test frame.....	70
F.2.3	Loading equipment.....	71
F.2.4	Test room/chamber.....	72
F.2.5	Balance	72
F.3	Test conditions	72
F.3.1	Environmental conditions.....	72
F.3.2	Restraints/boundary conditions.....	72
F.4	Test specimen	73
F.4.1	Size and characteristics.....	73
F.4.2	Number of specimens	73
F.4.3	Conditioning.....	73
F.5	Test procedure	73
F.5.1	Types of loading of the specimen.....	73
F.5.2	General.....	73
F.5.3	Test without loading (minimum normative requirement)	73
F.5.4	Test with additional load	74
F.6	Test report	75
F.7	Extended field of application	76
Annex G (normative) Suspension component – Functional test.....		77
Annex H (normative) Perimeter trim component- Functional test, determination of load bearing capacity.....		80
H.1	General.....	80
H.2	Basic test for perimeter trims.....	80
H.2.1	Test installation.....	80
H.2.2	Fixing the perimeter trims.....	81
H.2.3	Test load	81
H.2.4	Number of tests.....	82
H.2.5	Application of the load	82
H.2.6	Perimeter trim thickness.....	83
H.2.7	Alternative testing.....	83
H.2.8	Test report	83
Annex I (normative) Reaction to fire test - Mounting and fixing		85
I.1	Dimensions of the test rig in accordance with EN 13823	85
I.2	Ceiling membrane components	85
I.2.1	Mounting and fixing in accordance with EN 13823	85
I.2.2	End use application rules	92
I.3	Substructure components	92
I.3.1	General.....	92
I.3.2	Mounting and fixing in accordance with EN 13823	93
I.3.3	End use application rules	94
I.4	Reaction to fire requirements for small products and components	95
I.4.1	Principles.....	95
I.4.2	Small kit components.....	95
I.4.3	Small constituents	95
I.4.4	Linear joint kit components.....	96
I.4.5	Embedded constituents	96

I.4.6	Provisions accompanying performance declarations.....	96
Annex J	(normative) Mechanical strength, safety against failure – baffles.....	97
J.1	General	97
J.2	Test equipment	97
J.2.1	Loading brackets	97
J.2.2	Conditioning chamber	97
J.2.3	Loading device	97
J.3	Test specimen.....	97
J.4	Number of specimen	97
J.5	Conditioning	97
J.6	Test set up (see Figure J.1)	98
J.7	Test procedure.....	99
J.8	Performance criteria, assessment, evaluation and expression of the test result	100
J.9	Test report.....	100
Annex K	(informative) Reaction to fire performance - Classified without the need for further testing (CWFT)	101
Annex L	(informative) Guidance on the choice of attestation of conformity system	102
Annex M	(informative) Significant technical changes between this European Standard and the previous edition	105
Annex ZA	(informative) Clauses of this European Standard addressing essential requirements or other provisions of EU Directives.....	106
ZA.1	Scope and relevant clauses	106
ZA.2	Procedure for attestation of conformity.....	111
ZA.2.1	Systems of attestation of conformity	111
ZA.2.2	EC certificate of conformity and EC declaration of conformity.....	117
ZA.3	CE marking.....	119
ZA.3.1	General	119
ZA.3.2	Examples of CE marking for suspended ceilings products according to EN 13964.....	119
ZA.3.3	Examples of CE marking for products according to EN 13964 and at the same time according also to (an)other harmonized technical specification(s).....	126
	Bibliography.....	128

Foreword

This document (EN 13964:2014) has been prepared by Technical Committee CEN/TC 277 “Suspended ceilings”, the secretariat of which is held by NBN.

This European Standard shall be given the status of a national standard, either by publication of an identical text or by endorsement, at the latest by September 2014, and conflicting national standards shall be withdrawn at the latest by December 2015.

Attention is drawn to the possibility that some of the elements of this document may be the subject of patent rights. CEN [and/or CENELEC] shall not be held responsible for identifying any or all such patent rights.

This document supersedes EN 13964:2004.

Changes introduced in this document compared with the previous version have been indicated in Annex M.

This document has been prepared under a mandate given to CEN by the European Commission and the European Free Trade Association, and supports essential requirements of EU Directive(s).

For relationship with EU Directive(s), see informative Annex ZA, which is an integral part of this document.

According to the CEN-CENELEC Internal Regulations, the national standards organizations of the following countries are bound to implement this European Standard: Austria, Belgium, Bulgaria, Croatia, Cyprus, Czech Republic, Denmark, Estonia, Finland, Former Yugoslav Republic of Macedonia, France, Germany, Greece, Hungary, Iceland, Ireland, Italy, Latvia, Lithuania, Luxembourg, Malta, Netherlands, Norway, Poland, Portugal, Romania, Slovakia, Slovenia, Spain, Sweden, Switzerland, Turkey and the United Kingdom.

Introduction

Diagram 1 shows the relationship between this European Standard prepared by CEN/TC 277 "Suspended ceilings" and other European Standards prepared by CEN/TC 241 "Gypsum products" and CEN/TC 112 "Wood-based panels".

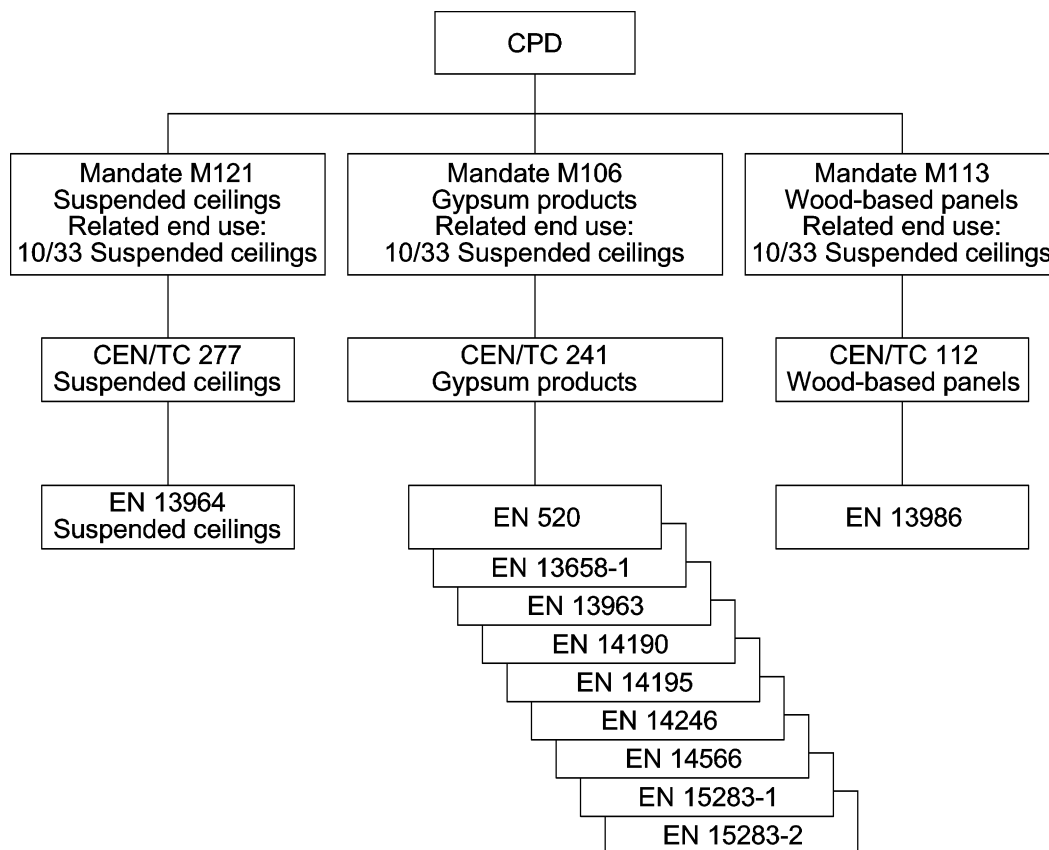

Diagram 1

1 Scope

This European Standard covers membranes, individual substructure components, substructure kits and suspended ceiling kits intended to be placed on the market. It covers suspended ceilings sold as a complete kit, substructures placed on the market as kits, individual components (products) of such substructures, and membrane components. It includes test methods and methods of assessment, as well as provisions for the evaluation of conformity and for the marking of the products to the requirements of this European Standard.

In the absence of any other European Standard, this European Standard specifies dimensions, tolerances and, where relevant, performance requirements, for commonly available ceiling substructures and membrane components.

This European Standard covers the following characteristics:

- reaction to fire;
- fire resistance (suspended ceiling kits only);
- release and/or content of dangerous substances:
 - release of asbestos (content) (suspended ceiling kits and membrane components only);
 - release of formaldehyde (suspended ceiling kits and membrane components only);
 - other dangerous substances;
- shatter properties (safe breakage)/impact resistance (for suspended ceiling kits and membrane components of brittle materials in suspended ceiling kits only);
- flexural tensile strength;
- load bearing capacity, tolerances and dimensions;
- electrical safety (as adequacy of the product to avoid electrocution from installations that may be part of the assembled ceiling, using electricity, such as ventilation devices and lighting);
- direct airborne sound insulation (suspended ceiling kits only);
- sound absorption (suspended ceiling kits and membrane components only);
- thermal conductivity (suspended ceiling kits and membrane components only);
- susceptibility to the growth of harmful micro-organisms;
- resistance to fixings (relevant for components that are mechanically fixed);
- durability of flexural tensile strength and load bearing capacity against moisture.

This European Standard also covers the following requirements:

- colour and light reflectance;
- installation.

This European Standard does not cover the following:

- ceiling substructures and membrane component covered by other harmonized European Standards, for insitu formed ceilings, covered by other European technical specifications, for which it is the installer, not the component manufacturer, who takes responsibility for ensuring that the complete installed suspended ceiling meets any regulatory requirements to which it is subject;
 - stretched ceilings covered by EN 14716;
 - ceilings in mobile buildings, caravans and other forms of transportation;
 - characteristics needed for special applications, for which additional characteristics other than covered by this European Standard would need to be complied with;
 - suspended ceilings intended for uses in ceilings subject to water penetration requirements;
 - ceilings used externally where requirements other than covered by this standard would apply (tunnels, canopies, petrol stations, arcades, open sports facilities, car parks, etc.);
 - heavy duty suspended ceilings or their supporting construction (e.g. ceilings that can be walked on);
 - ceilings made from fire protective boards;
 - the performance and health and safety requirements of light fittings and other features that, optionally, are included in the suspended ceiling;
 - panels from materials covered in other harmonized European standards already prepared by CEN/TC 241 and CEN/TC 112 (see NOTE 1);
- NOTE 1 These standards have been developed by CEN/TC 241 under the Mandate M/106 “Gypsum products” and by CEN/TC 112 under the Mandate M/113 “Wood-based panels”.
- anchors covered by other European technical specifications.

This European Standard also gives certain specifications for the installed suspended ceiling system (see NOTE 2).

NOTE 2 There are two reasons for this:

- the individual components and kits may have to meet certain requirements in order for the installed system to be able to meet the requirement when the system is installed, and
- it is appropriate, for ease of reference, to give both component/kit requirement and installed system requirement in the same document, given the relationship between them.

This European Standard provides information for the various parties responsible for designing, manufacturing and specifying/selecting suspended ceilings used for interior applications in general building and civil engineering structures.

2 Normative references

The following documents, in whole or in part, are normatively referenced in this document and are indispensable for its application. For dated references, only the edition cited applies. For undated references, the latest edition of the referenced document (including any amendments) applies.

EN 120, *Wood based panels — Determination of formaldehyde content — Extraction method called the perforator method*

EN 312, *Particleboards — Specifications*

EN 335, *Durability of wood and wood-based products — Use classes: definitions, application to solid wood and wood-based products*

EN 350 (all parts), *Durability of wood and wood-based products — Natural durability of solid wood*

EN 351 (all parts), *Durability of wood and wood-based products — Preservative-treated solid wood*

EN 460, *Durability of wood and wood-based products — Natural durability of solid wood — Guide to the durability requirements for wood to be used in hazard classes*

EN 573-3, *Aluminium and aluminium alloys — Chemical composition and form of wrought products — Part 3: Chemical composition and form of products*

EN 599 (all parts), *Durability of wood and wood-based products — Performance of preventive wood preservatives as determined by biological tests*

EN 622-1, *Fibreboards — Specifications — Part 1: General requirements*

EN 717-1, *Wood-based panels — Determination of formaldehyde release — Part 1: Formaldehyde emission by the chamber method*

EN 717-2, *Wood-based panels — Determination of formaldehyde release — Part 2: Formaldehyde release by the gas analysis method*

EN 1396:2007, *Aluminium and aluminium alloys — Coil coated sheet and strip for general applications — Specifications*

EN 1912, *Structural Timber — Strength classes — Assignment of visual grades and species*

EN 1991-1-4¹⁾, *Eurocode 1: Actions on structures — Part 1-4: General actions — Wind actions*

EN 1995-1-1²⁾, *Eurocode 5: Design of timber structures — Part 1-1: General — Common rules and rules for buildings*

EN 1998-1³⁾, *Eurocode 8: Design of structures for earthquake resistance — Part 1: General rules, seismic actions and rules for buildings*

EN 10143, *Continuously hot-dip coated steel sheet and strip — Tolerances on dimensions and shape*

EN 10152, *Electrolytically zinc coated cold rolled steel flat products for cold forming — Technical delivery conditions*

EN 10169, *Continuously organic coated (coil-coated) steel flat products — Technical delivery conditions*

EN 10346, *Continuously hot-dip coated steel flat products — Technical delivery conditions*

EN 12600, *Glass in building — Pendulum test — Impact test method and classification for flat glass*

1) Superseded ENV 1991-2-4 in 2005.

2) Superseded ENV 1995-1-1 in 2004.

3) Superseded ENV 1998-1-3 in 2004.

- EN 12664, *Thermal performance of building materials and products — Determination of thermal resistance by means of guarded hot plate and heat flow meter methods — Dry and moist products of medium and low thermal resistance*
- EN 12667, *Thermal performance of building materials and products — Determination of thermal resistance by means of guarded hot plate and heat flow meter methods — Products of high and medium thermal resistance*
- EN 13162, *Thermal insulation products for buildings — Factory made mineral wool (MW) products — Specification*
- EN 13171, *Thermal insulation products for buildings — Factory made wood fibre (WF) products — Specification*
- EN 13245-1:2010, *Plastics — Unplasticized poly(vinyl chloride) (PVC-U) profiles for building applications — Part 1: Designation of PVC-U profiles*
- EN 13245-2:2008, *Plastics — Unplasticized poly(vinyl chloride) (PVC-U) profiles for building applications — Part 2: PVC-U profiles and PVC-UE profiles for internal and external wall and ceiling finishes*
- EN 13501-1, *Fire classification of construction products and building elements — Part 1: Classification using test data from reaction to fire tests*
- EN 13501-2, *Fire classification of construction products and building elements — Part 2: Classification using data from fire resistance tests, excluding ventilation services*
- EN 13823, *Reaction to fire tests for building products — Building products excluding floorings exposed to the thermal attack by a single burning item*
- EN ISO 354, *Acoustics — Measurement of sound absorption in a reverberation room (ISO 354)*
- EN ISO 717-1, *Acoustics — Rating of sound insulation in buildings and of building elements — Part 1: Airborne sound insulation (ISO 717-1)*
- EN ISO 2813, *Paints and varnishes — Determination of specular gloss of non-metallic paint films at 20°, 60° and 85° (ISO 2813)*
- EN ISO 6946, *Building components and building elements — Thermal resistance and thermal transmittance — Calculation method (ISO 6946)*
- EN ISO 9001:2008, *Quality management systems — Requirements (ISO 9001:2008)*
- EN ISO 10140 (all parts), *Acoustics — Laboratory measurement of sound insulation of building elements (ISO 10140)*
- EN ISO 10211, *Thermal bridges in building construction — Heat flows and surface temperatures — Detailed calculations (ISO 10211)*
- EN ISO 10456, *Building materials and products — Hygrothermal properties — Tabulated design values and procedures for determining declared and design thermal values (ISO 10456)*
- EN ISO 10848-2, *Acoustics — Laboratory measurement of the flanking transmission of airborne and impact sound between adjoining rooms — Part 2: Application to light elements when the junction has a small influence (ISO 10848-2)*
- EN ISO 11654, *Acoustics — Sound absorbers for use in buildings — Rating of sound absorption (ISO 11654)*
- EN ISO 11925-2, *Reaction to fire tests — Ignitability of building products subjected to direct impingement of flame — Part 2: Single-flame source test (ISO 11925-2)*

EN ISO 12944-3, *Paints and varnishes — Corrosion protection of steel structures by protective paint systems — Part 3: Design considerations (ISO 12944-3)*

ISO 1006, *Building construction — Modular co-ordination — Basic module*

ISO 7724-2, *Paints and varnishes — Colorimetry — Part 2: Colour measurement*

ISO 7724-3, *Paints and varnishes — Colorimetry — Part 3: Calculation of colour differences*

3 Terms and definitions

For the purposes of this document, the following terms and definitions apply.

3.1 General

3.1.1 ceiling

construction covering the underside of a floor or roof, providing the overhead surface

3.1.2 suspended ceiling

ceiling hung by a suspension from or by a directly fixed substructure or perimeter trim to the load bearing structure (floor, roof, beam and walls) at a distance from the floor or roof above

3.1.3 suspended ceiling for interior application

application not exposed to outside weather conditions (wind, rain, humidity, pollution, etc.)

3.1.4 suspended ceiling kit

set of components that need to be put together to be installed permanently in the works

Note 1 to entry: Although the components of the kit may be produced by more than one manufacturer, it has to be placed on the market in a way that enables it to be purchased in one transaction.

Note 2 to entry: The substructure may be a complete kit or made up of individual components.

Note 3 to entry: Although it may contain all necessary components, the kit does not have to contain all the components needed to form an assembled suspended ceiling system.

3.1.5 assembled suspended ceiling system

suspended ceiling system components that are adapted to each other, and which may originate from different sources, which have been installed together in the works

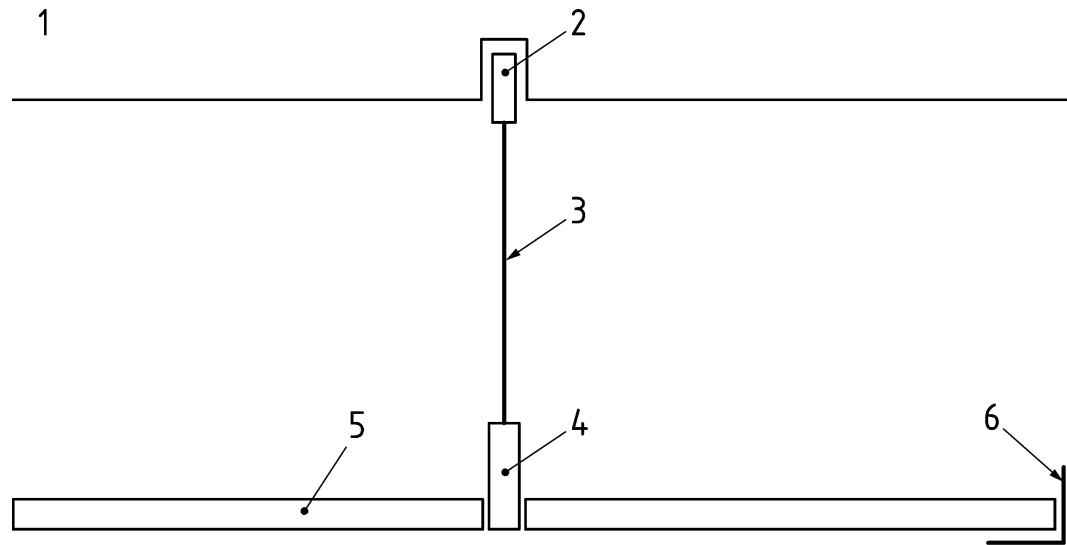

Key

1	load bearing structure	4	supporting member
2	top fixing	5	ceiling membrane component
3	suspension	6	perimeter trim

Figure 1 — Principal suspended ceiling components (not all components are necessarily used in an installation)

3.2 Suspended ceiling and substructure components (see Figure 1)

3.2.1 General

3.2.1.1

substructure

suspending frame that supports the ceiling membrane

Note 1 to entry: May be a complete kit or made up of individual components. There are three types of substructure: exposed, concealed and semi-concealed substructures.

3.2.1.2

exposed substructure

substructure whose underside is exposed

3.2.1.3

concealed substructure

substructure whose underside is not exposed

3.2.1.4

semi-concealed substructure

substructure where the underside is exposed in one direction and the intermediate profiles, which are at an angle to the support profiles, are concealed

3.2.1.5

suspension component

part of the substructure, connecting it to the load bearing structure

Note 1 to entry: May be part of a kit or part of an assembled ceiling system.

3.2.2 Fixing, connections and supports

3.2.2.1

top fixing

fixing which connects the suspension components or the substructure directly to the load bearing structure

3.2.2.2

perimeter trim fixing, including corridor fixing

fixing which connects the perimeter trim directly to the load bearing structure

3.2.2.3

sub-structural connection

fixing component used to connect the anchoring component, suspension component, substructure and ceiling membrane component

3.2.2.4

supporting member

suspended component of the substructure with direct connection to the suspension component or directly fixed component

3.2.2.5

cross/secondary supporting component

component of the substructure which spans between two supporting components and with a direct supporting function for the ceiling membrane component

3.2.2.6

perimeter trim

section fixed at the perimeter of the ceiling to support the components of either the substructure or the ceiling membrane, or both, or fixed to and carried by the ceiling membrane itself

3.2.2.7

access component

component of the substructure or of the substructure and membrane component with a special access facility to enable a particular part of the ceiling membrane to be removed

3.2.2.8

splice

mechanical connection between substructure sections

3.3 Ceiling membranes and ceiling membrane components

3.3.1

ceiling membrane

exposed surface of the ceiling facing the room, excluding any exposed substructure

3.3.2

ceiling membrane component

product forming part of the ceiling membrane (e.g. a tile or plank); the ceiling membrane component can have any form (e.g. solid, open, corrugated, mesh)

3.3.3

volume membrane component

component of which the edges are shaped within the full material thickness (see Figure 3)

3.3.4

thin gauge membrane component

component of which the edges are achieved by forming the basic sheet material (see Figure 4) and where the thickness permits permanent forming

3.3.5

tile

square or rectangular component with the length (l)/width (w) ratio within the range $1 \leq l/w \leq 2$ (see Figure 2)

3.3.6

plank

rectangular component with the length (l)/width (w) ratio within the range $2 < l/w \leq n$ (see Figure 2)

3.3.7

linear component

component of relatively narrow width (w) and of which the length (l) is generally made to measure (see Figure 2)

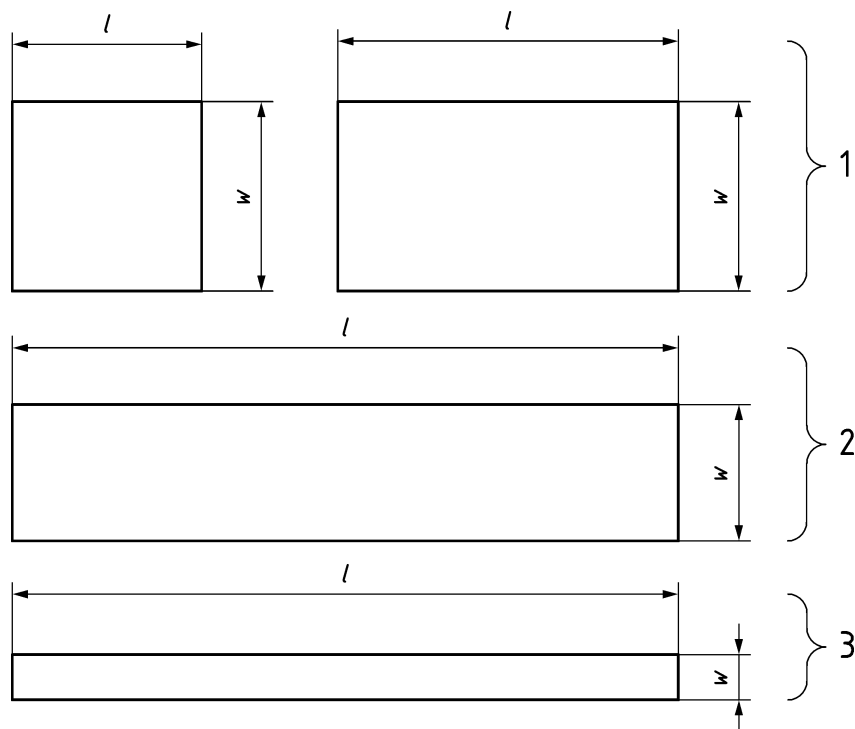

Key

- 1 tile
- 2 plank
- 3 linear component

Figure 2 — Ceiling membrane components

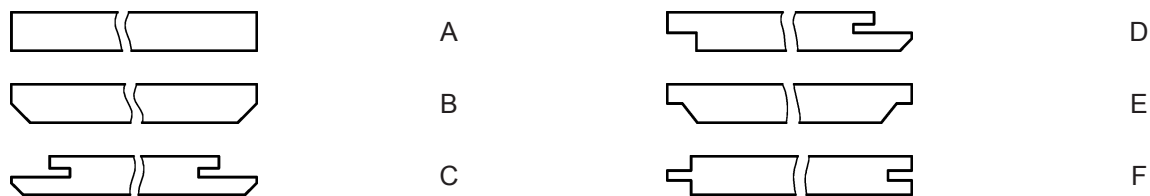

Key

- | | | | |
|---|----------|---|---------------------|
| A | squared | D | rebated and grooved |
| B | bevelled | E | rebated |
| C | grooved | F | tongued and grooved |

NOTE Various edges may be used in different combinations. Edges may be designated using the relevant letter code. Other edge forms are possible and available.

Figure 3 — Typical edge details of volume ceiling membrane components

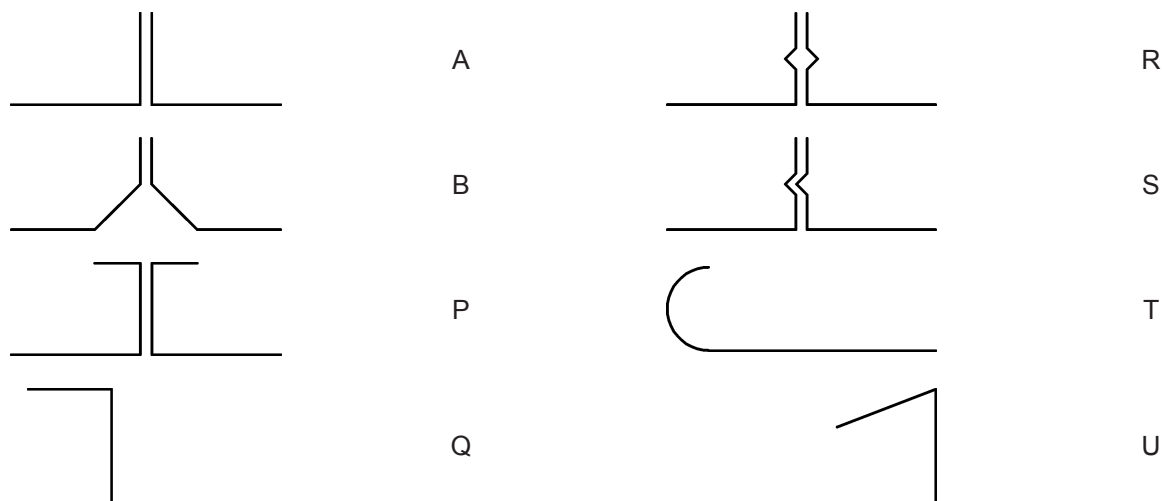

Key

- | | | | |
|---|----------------|---|---------------------|
| A | squared | R | rilled or bumped |
| B | bevelled | S | tongued and grooved |
| P | return flanged | T | rounded |
| Q | rebated | U | reverted |

NOTE Various edges may be used in different combinations. Edges may be designated using the relevant letter code. Other edge forms are possible and available.

Figure 4 — Typical edge details of thin gauge ceiling membrane components

3.4 Typical suspended ceiling systems using volume or thin gauge materials

3.4.1

suspended ceiling systems with membrane components fixed on the substructure

assembly with type A, B or F shaped edges (see Figure 3) where the boards are fixed on the substructure (concealed substructure)

Note 1 to entry: The membrane components are butted and can be visible or jointed (not visible = jointless surface) (see Figure 5).

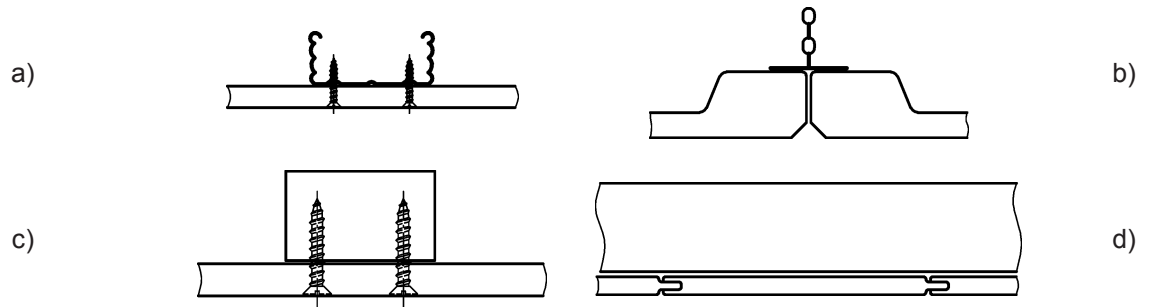

Figure 5 — Examples for possible designs with membrane components fixed on the substructure

3.4.2

suspended ceiling system with various edge types (A, B, C, D, E – see Figure 3) for volume gauge materials and with type A and Q (see Figure 4) edges for thin gauge materials assembly in which different edge types are used

Note 1 to entry: See Figure 6 that shows very common applications of how these systems are implemented.

Note 2 to entry: The substructure can be exposed, semi-concealed or concealed.

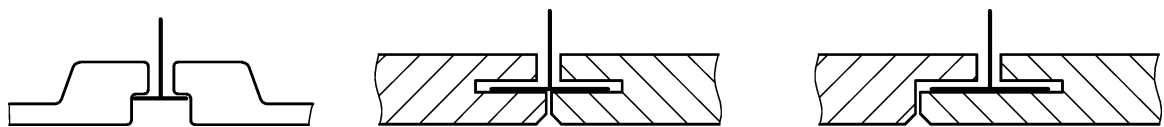
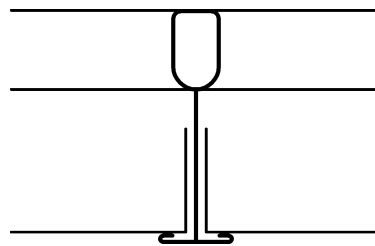

Figure 6 — Examples for possible designs with various edge types

3.4.3

lay-in suspended ceiling system

assembly with Type A or Type P shaped edges (see Figure 4) that is supported by an exposed substructure (see Figure 7)



NOTE Other designs may exist.

Figure 7 — Example for a lay-in suspended ceiling system

3.4.4

rebated lay-in suspended ceiling system

assembly with Type Q edges (see Figure 4), supported by an exposed substructure (see Figure 8)

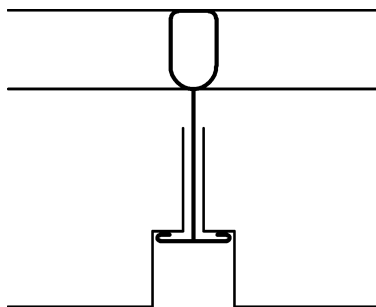

NOTE Other designs may exist.

Figure 8 — Example for a rebated lay-in suspended ceiling system

3.4.5

clip-in suspended ceiling system

assembly, normally with Type R edges (see Figure 4) that are clipped onto a concealed substructure (see Figure 9)

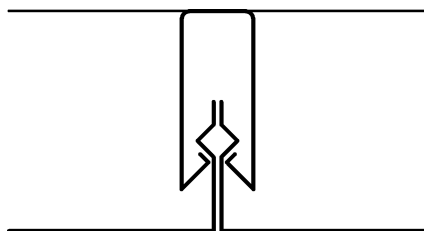

NOTE Other designs may exist.

Figure 9 — Example for a clip-in suspended ceiling system

3.4.6

hook-on suspended ceiling system

assembly, one side of which has Type Q edge and the opposite side has a Type U edge (see Figure 4) supported by a concealed substructure (see Figure 10)

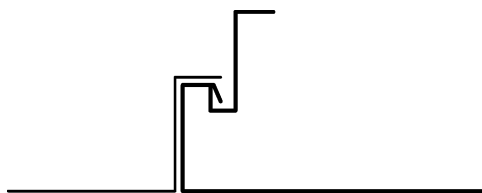

NOTE Other designs may exist.

Figure 10 — Example for a hook-on suspended ceiling system

3.4.7

linear suspended ceiling system (open or closed)

assembly with linear components that are fixed to a substructure (see Figure 11)

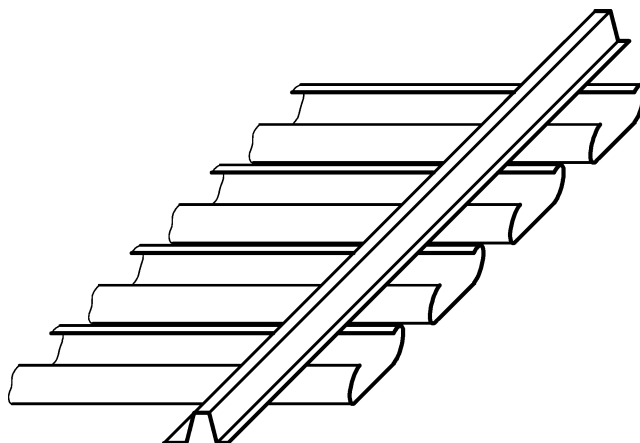

NOTE Other designs may exist.

Figure 11 — Example for a linear suspended ceiling system

**3.4.8
baffle**

assembly of vertically placed linear membrane components installed at a certain distance from each other (see Figure 12)

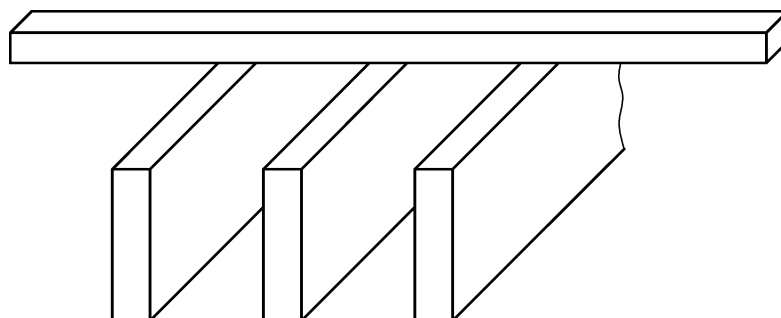

NOTE Other design systems may exist.

Figure 12 — Example for a baffle

**3.4.9
open cell**

membrane component in grid form (see Figure 13)

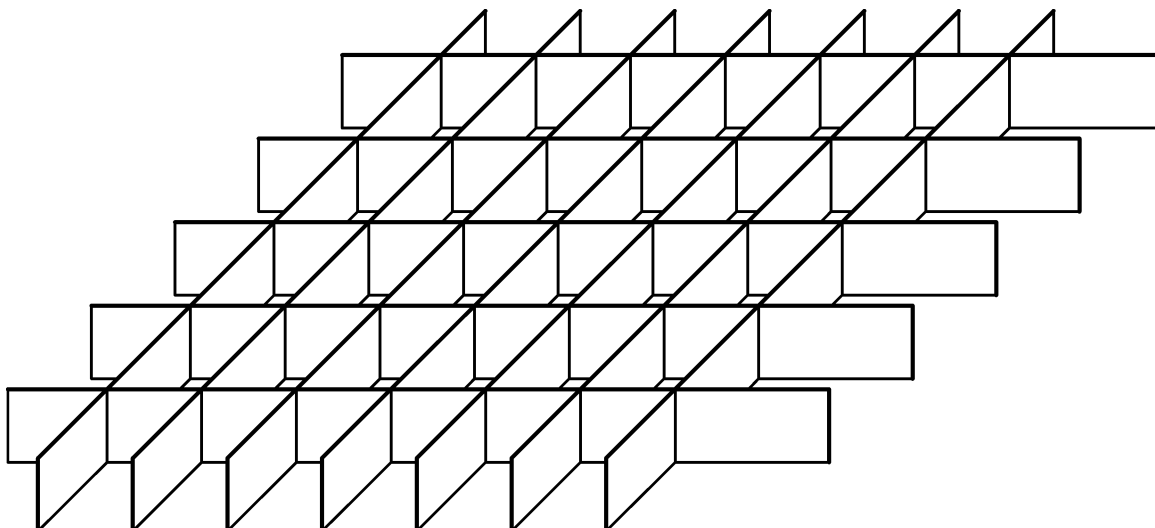

NOTE Other designs may exist.

Figure 13 — Example for an open grid cell

4 Requirements

4.1 Dimensions and tolerances – General

The materials and products used in the construction of suspended ceilings shall comply with the requirements of this European Standard.

If there is no separate product standard available, the tolerances for profiles shall comply with Table 1 and Table 2. The substructure for linear components shall comply with Table 5.

The manufactured dimensions and tolerances for volume and thin gauge membrane components shall comply with Table 3 and Table 4 unless a separate product standard is available.

The manufactured dimensions and tolerances for linear components shall comply with Table 5.

Where relevant, measurements shall be made with suitable accuracy.

Dimensions and the corresponding tolerances shall be declared.

4.2 Modular dimensions

The plan dimension of suspended ceiling substructure and membrane components shall be based on modular co-ordination as standardized in ISO 1006.

The commonly used modular dimensions of membrane components shall be based on $n \times 100$ mm or on sub-modules of $n \times 50$ mm or $n \times 25$ mm.

If there is no separate product standard available, Table 2 applies.

Dimensions and the corresponding tolerances shall be declared.

Table 1 — Grids in assembled suspended ceiling systems – Cross sectional tolerances

Cross section	Tolerances with regard to nominal dimensions				
	W (mm)	w1 (mm)	w2 (mm)	h (mm)	α
<p>T-section</p> 	+ 0,3 - 0,3	+ 0,3 - 0,3	+ 0,3 - 0,3	–	+ 1,5 ⁰ - 1,5 ⁰
<p>Z-section</p>  <p>Key 1 parallel to bottom flange</p>	+ 0,3 - 0,3	+ 0,3 - 0,3	+ 0,3 - 0,3	–	+ 1,5 ⁰ - 1,5 ⁰
<p>Bandraaster</p> 	+ 0,3 - 0,3	+ 0,3 - 0,3	–	+ 0,3 - 0,3	+ 3 ⁰ - 3 ⁰
<p>Furring channel</p> 	+ 0,3 - 0,3	–	–	+ 0,3 - 0,3	+ 3 ⁰ - 3 ⁰
<p>Perimeter trims</p> 	+ 0,5 - 0,5	–	–	+ 0,3 - 0,3	+ 0 ⁰ - 3 ⁰
<p>NOTE 1 Measurements in millimetres are related to the nominal dimensions.</p> <p>NOTE 2 α nominal = 90°.</p>					

Table 2 — Supporting components – Modular tolerance

<p>Main runners (T-section and bandraster)</p> <p>Substructure sections</p>	 <p>Key</p> <p>1 interlocking holes in section 2 splice in supporting component</p> <p>Definition: X : 1 Slot distance Y : Sum of slot distances $\geq 1,25$ m including or excluding one splice</p> <p>Tolerance: X : $\pm 0,25$ mm Y : $\pm 0,30$ mm</p>
<p>Centre point substructure</p>	 <p>Definition: M : axis- axis distance between 2 main runners X : axis- axis distance between 2 cross tees</p> <p>Tolerance: M : $\pm 0,25$ mm / m X : $\pm 0,25$ mm</p>

Table 2 (continued)

All profiles

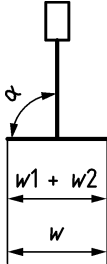
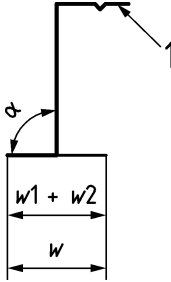
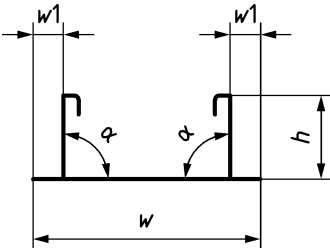
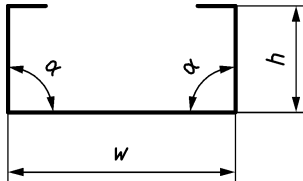
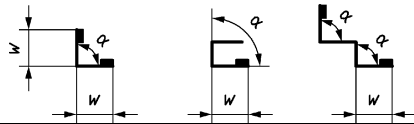
Bow : $\leq 1,5 \text{ mm / m}$

Camber : $\leq 1,5 \text{ mm / m}$

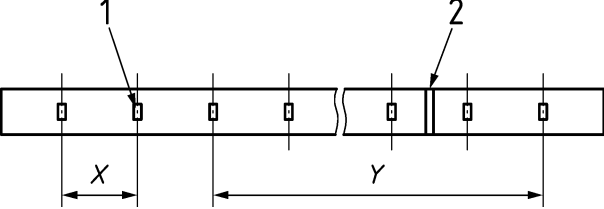
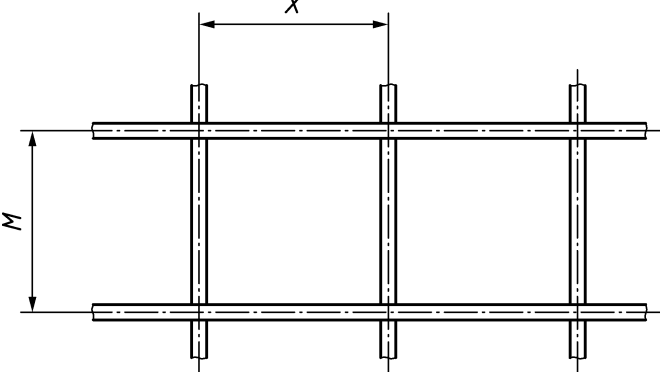
Twist : $\leq 2^\circ / \text{m}$

NOTE Squareness and flatness depend on the accuracy of the installation.

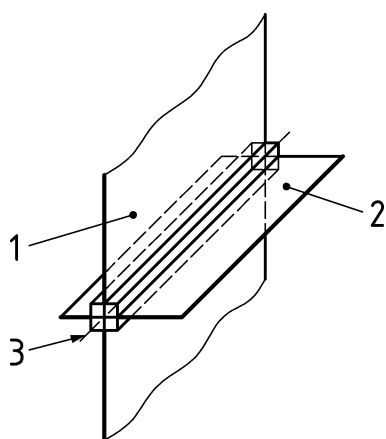

Key

- 1 vertical plane
- 2 horizontal plane
- 3 centroidal axis

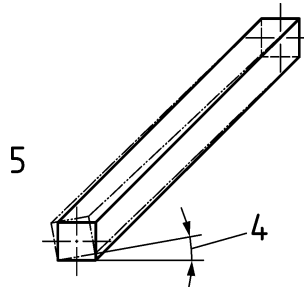
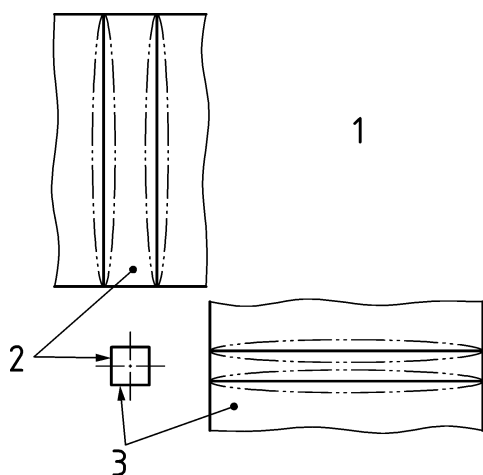

Key

- 1 camber
- 2 horizontal plane
- 3 vertical plane
- 4 twist
- 5 bow

Table 3 — Tolerances of volume membrane components

Cross section	Edge detail (mm)	Length (mm)	Width (mm)	Thickness (mm)	Squareness deviation from 90°	Flatness positive and negative bending	
A - squared edge B - bevelled edge		± 1,5	± 1,5	± 1,5	1/500	maximum tolerance = 1/300 of the measured length	
C - grooved edge	a	± 0,5	± 1,5	± 1,5	± 1,5	1/500	maximum tolerance = 1/300 of the measured length
	b	± 0,3					
c	± 0,3						
D - rebated and grooved edge	a	± 0,3	± 1,5	± 1,5	± 1,5	1/500	maximum tolerance = 1/300 of the measured length
	b	± 0,5					
	c	± 0,3					
E - rebated edge	a	± 0,5	± 1,5	± 1,5	± 1,5	1/500	maximum tolerance = 1/300 of the measured length
	b	± 0,6					
F - tongued and grooved edge	a	± 0,5	± 1,5	± 1,5	± 1,5	1/500	maximum tolerance = 1/300 of the measured length
	b	± 0,3					
	c	± 0,3					
	d	± 0,3					
NOTE	Measurements in millimetres are related to the nominal dimensions.						

Table 4 — Tolerances of thin gauge membrane components ^a



<p>a. Panel sizes:</p> <ul style="list-style-type: none"> - for lengths $\geq 1\ 000$ mm $(\begin{smallmatrix} 0 \\ -0,4 \end{smallmatrix})\text{mm / m}$ - for lengths $< 1\ 000$ mm $(\begin{smallmatrix} 0 \\ -0,5 \end{smallmatrix})\text{mm}$ - for width $(\begin{smallmatrix} 0 \\ -0,4 \end{smallmatrix})\text{mm}$ 						
<p>b. Flatness:</p> <p>Key</p> <p>1 tolerance b</p> <p>2 tolerance a</p>						
$l = \text{length (mm)}$	$0 < l \leq 1\ 000$		$1\ 000 < l \leq 2\ 000$		$2\ 000 < l \leq 3\ 000$	
$b = \text{width (mm)}$	a	b	a	b	a	b
$0 < b \leq 400$	- 0,5 + 0,5	- 0,2 + 3,0	- 0,5 + 1,5	- 0,2 + 4,0	- 0,5 + 3,0	- 0,2 + 6,0
$400 < b \leq 500$	- 0,5 + 0,5	- 0 + 4,0	- 0,5 + 1,5	- 0 + 5,0	- 0,5 + 3,5	- 0 + 7,0
$500 < b \leq 625$	- 0,5 + 0,5	- 0 + 6,0	- 0,5 + 1,5	- 0 + 7,0	- 0,5 + 4,0	- 0 + 9,0
$625 < b \leq 1\ 250$	- 0,5 + 0,5	- 0 + 10,0	- 0,5 + 1,5	- 0 + 13,0	-	-
<p>c. Angularity of the long edge in relation to short edge</p> <p>Panel width up to 625 mm $\pm 0,5$ mm</p> <p>Panel width 625 mm to 1 250 mm $\pm 0,6$ mm</p> <p>Key</p> <p>1 Panel width</p>						
<p>d. Depth of stops/supports $\pm 0,3$ mm (measured on panel cut out edge)</p>						
<p>Edge</p>		<p>Cut-out edge</p>				
<p>Deviations from 90° angle on vertical upstand are dependent on the production process and the relative suspension systems. There are no fixed tolerances.</p>						
<p>For corrugated membrane components the deviations should be measured on a line drawn through the lowest point of the corrugations.</p>						
<p>NOTE Measurements in millimetres are related to the nominal dimensions.</p>						
<p>^a The tolerances are valid for unperforated thin gauge membrane components and for perforated thin gauge membrane components with a hole diameter of maximum 4 mm and maximum 25 % open area.</p>						

Table 5 — Definitions and tolerances of linear ceiling systems

<p>Definition</p> <p>Ceiling components of relative narrow width and of which the length is generally made to measure</p> <p>Width max. 400 mm</p> <p>The linear components attach with their sides to the carriers. In general the angle between linear panel and carrier is 90°</p> <ul style="list-style-type: none"> – The sides of the linear components can be executed in many different shapes – At both ends the linear components are open – The joint between the sides of the components can have a width of 0 mm to X mm – The modular dimension is component-width + joint – The open joints between the components may be closed with a joint profile 	<p>Key</p> <table border="0"> <tr> <td>1 load bearing structure</td> <td>5 linear component</td> </tr> <tr> <td>2 top fixing</td> <td>6 perimeter trim</td> </tr> <tr> <td>3 suspension</td> <td>7 system height</td> </tr> <tr> <td>4 supporting member</td> <td></td> </tr> </table> <p>Key</p> <table border="0"> <tr> <td>1 load bearing structure</td> <td>6 linear component width</td> </tr> <tr> <td>2 top fixing</td> <td>7 joint</td> </tr> <tr> <td>3 suspension</td> <td>8 linear component module</td> </tr> <tr> <td>4 supporting member</td> <td>9 joint profile</td> </tr> <tr> <td>5 system height</td> <td>10 linear component</td> </tr> </table>	1 load bearing structure	5 linear component	2 top fixing	6 perimeter trim	3 suspension	7 system height	4 supporting member		1 load bearing structure	6 linear component width	2 top fixing	7 joint	3 suspension	8 linear component module	4 supporting member	9 joint profile	5 system height	10 linear component
1 load bearing structure	5 linear component																		
2 top fixing	6 perimeter trim																		
3 suspension	7 system height																		
4 supporting member																			
1 load bearing structure	6 linear component width																		
2 top fixing	7 joint																		
3 suspension	8 linear component module																		
4 supporting member	9 joint profile																		
5 system height	10 linear component																		

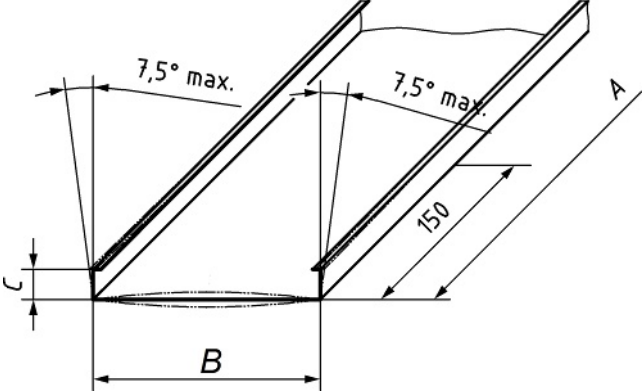
Table 5 (continued)

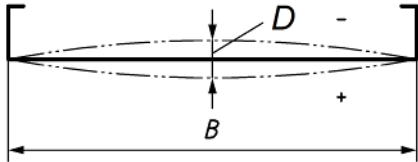
<p>Tolerances of linear components (dimensions in millimetres)</p> <p>Dimensions:</p> <p>Component height $\pm 0,5$</p> <p>Component length</p> <ul style="list-style-type: none"> - (850 < 3 000) mm $\pm 1,25$ - (3 000 \leq 6 000) mm $\pm 2,0$ <p>Component width $\pm 0,75$</p> <p>Due to material and production properties additional dimensional deviations occur because of spring-back at the panel ends</p>	 <p>Key</p> <ul style="list-style-type: none"> A linear component length B linear component width C linear component height
---	---

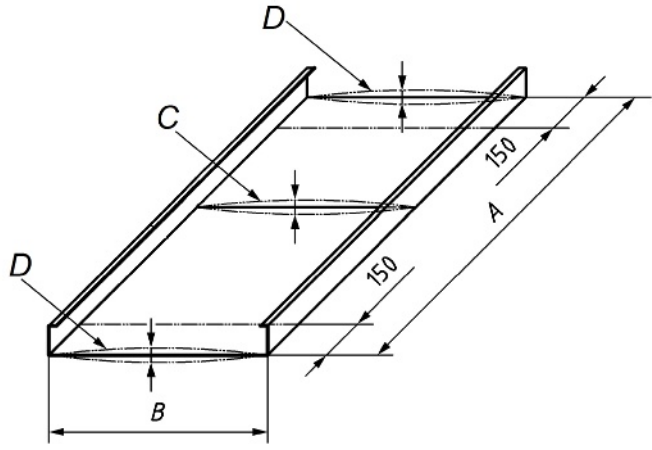
<p>Plane and waves (dimensions in millimetres)</p> <p>Plane</p>   <p>Key</p> <ul style="list-style-type: none"> A linear component length B linear component width C deviation from plane at A/2 panel length D deviation from plane at panel face 	 <ul style="list-style-type: none"> + convex - concave
--	---

Linear component width (in mm)			
$0 < B \leq 100$	$100 < B \leq 200$	$200 < B \leq 300$	$300 < B \leq 400$
C	C	C	C
- 1,0	- 1,25	- 1,5	- 1,75
+ 1,5	+ 2,0	+ 2,5	+ 2,7
D	D	D	D
- 1,5	- 2,5	-3,5	-4,0
+ 1,5	+ 2,0	+2,5	+2,7

Table 5 (continued)

<p>Waves</p>  <p>Key</p> <p>1 linear component span E positive wave F negative wave</p>		<p>Linear component width (in mm)</p> <table border="1" data-bbox="518 739 1436 884"> <thead> <tr> <th colspan="2" data-bbox="518 739 518 784">$0 < B \leq 200$</th> <th colspan="2" data-bbox="518 739 1436 784">$200 < B \leq 400$</th> </tr> <tr> <th data-bbox="518 784 518 828">E</th> <th data-bbox="518 784 518 828">F</th> <th data-bbox="518 784 981 828">E</th> <th data-bbox="518 784 1436 828">F</th> </tr> </thead> <tbody> <tr> <td data-bbox="518 828 518 884">- 0,5</td> <td data-bbox="518 828 518 884">+ 0,5</td> <td data-bbox="518 828 981 884">- 0,8</td> <td data-bbox="518 828 1436 884">+ 0,8</td> </tr> </tbody> </table>		$0 < B \leq 200$		$200 < B \leq 400$		E	F	E	F	- 0,5	+ 0,5	- 0,8	+ 0,8
$0 < B \leq 200$		$200 < B \leq 400$													
E	F	E	F												
- 0,5	+ 0,5	- 0,8	+ 0,8												
<p>Camber</p> <p>The deviation is maximum $1/1\ 500 \times$ linear component length, measured in the middle of the length of the linear component (equals 0,67 mm over 1,0 m length).</p>															
<p>Deflection of the linear components</p> <p>The maximum deflection between two supporting members/ points of support is $1/500 \times$ supporting member distance, measured in the middle between the supporting members/ points of support.</p>	 <p>Key</p> <p>1 supporting member distance (linear component span) 2 supporting member 3 linear component 4 linear component deflection ($1/500 \times$ supporting member distance)</p>														
<p>Tolerance of the supporting member module</p> <p>The tolerance of the supporting member module is $\pm 0,06$ mm on a linear component module of 100 mm.</p>															

Table 5 (continued)

<p>Tolerance of the supporting-member length</p> <p>The length of the supporting member is a multiple of the supporting members' module</p> <p>The total length of the supporting member follows from the number of supporting member modules, including the module-tolerance, minus a cutting tolerance that is determined by the manufacturer</p> <p>Production-wise each supporting member starts and ends in the joint of the punching module</p> <p>Supporting-member splices or manufacturer's installation instruction ensure the modular dimensions over the length of more supporting members</p>	 <p>Key</p> <p>A supporting member length = X x Module – cutting tolerance</p> <p>B modular length supporting member</p> <p>C supporting members' module</p> <p>1 module tolerance</p> <p>2 length tolerance</p> <p>3 cutting tolerance</p>
<p>Deflection of the supporting members</p> <p>The maximum deflection of the supporting members between two suspension points is 1/500 x suspension distance, measured in the middle between two suspension points (Class 1, Table 6)</p>	 <p>Key</p> <p>1 suspension distance (supporting member span)</p> <p>2 supporting member deflection</p> <p>3 linear component</p> <p>4 supporting member</p> <p>5 suspension</p>
<p>NOTE Measurements in millimetres are related to the nominal dimensions.</p>	

4.3 Mechanical resistance and stability of load bearing components

4.3.1 General

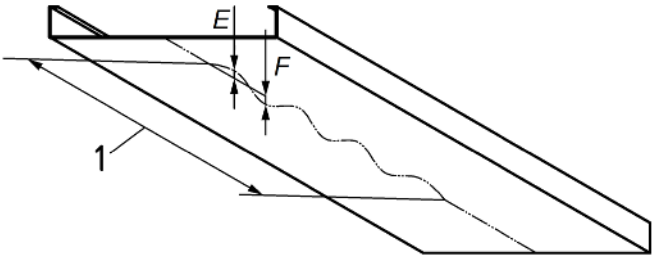
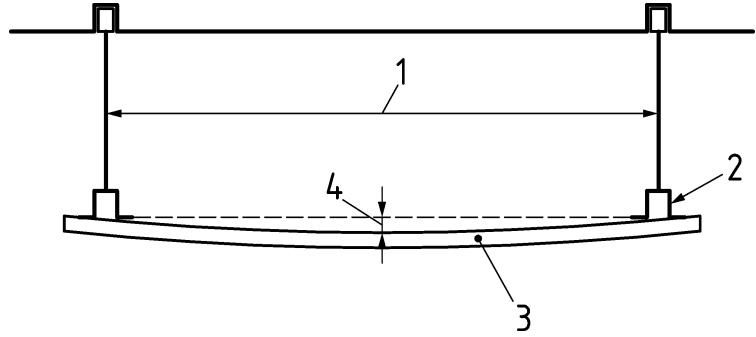
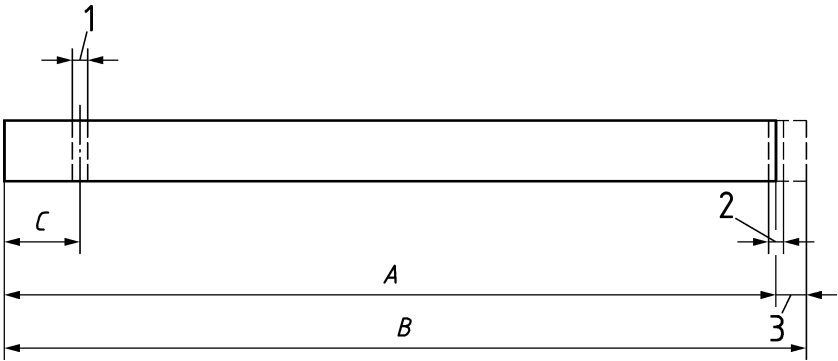
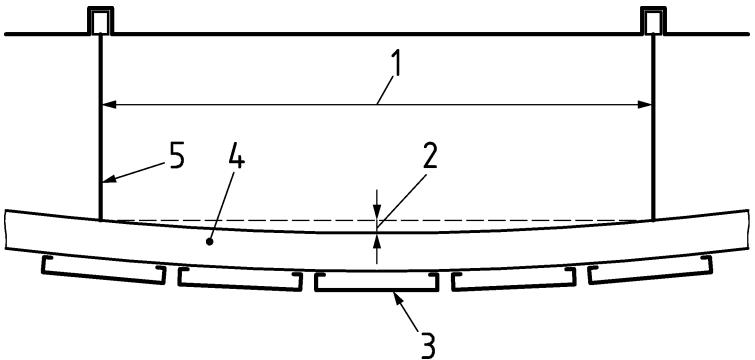
This clause covers only the load bearing components of the suspended ceiling. It does not cover the mechanical characteristics of membrane components, for which 4.6.2 applies.

4.3.2 Substructure

4.3.2.1 Load bearing performance

The load bearing performance of the substructure shall be established by testing each of its components individually in accordance with the relevant test contained in Clause 5, unless the dimensions, nature and design of the material allow load bearing performance and deformation to be calculated.

The substructure shall be classified in accordance with its deflection limits as given in Table 6.

Where the component, once tested, is used in a configuration different to that used in the test, its admissible load bearing capacity, if required, shall be estimated by using data from the test.

Table 6 — Classes of deflection - Substructure profiles

Class	Deflection (mm)
1	L/500 and not greater than 4,0
2	L/300
3	No limit

Where L is the span in millimetres between the suspension points.

4.3.2.2 Substructure materials

4.3.2.2.1 Steel substructure

Where the substructure is formed in hot-galvanized strip or sheet of unalloyed steel, the minimum steel grade used shall be DX 51D + Z according to EN 10346.

If other steel types are used, they shall conform to EN 10152 (ZE), EN 10169 or EN 10346 (ZA, AZ), as appropriate.

The thickness tolerance shall be in accordance with EN 10143.

For corrosion protection the minimum protection shall be in accordance with Table 9 related to the class of exposure (see Table 8) to be encountered.

4.3.2.2.2 Aluminium substructure

Where substructure members are made of aluminium alloy, the alloy shall be in accordance with EN 573-3 and have 0,2 % yield strength of at least 160 N/mm².

For corrosion protection, the minimum protection shall be that given in Table 9.

4.3.2.2.3 Timber substructure

The timber used for substructure shall conform at least to quality grade S 10 (MS 10) of EN 1912.

The moisture content of the timber shall not exceed 20 % by mass.

The minimum cross section of the primary timber element shall be (40 x 60) mm. The dimensions for secondary timber elements shall be at least (48 x 24) mm or (50 x 30) mm for both primary and secondary timber elements.

Timber supporting elements fixed directly to the building structure (that is without any suspension) shall have a minimum cross section of (48 x 24) mm.

For indoor applications, wood preservation is normally not necessary. Where protection against biological or other attack, is necessary, the relevant provisions of EN 335, EN 350, EN 351, EN 460 and/or EN 599 shall apply.

4.3.3 Suspension components and fasteners

4.3.3.1 Metal suspension components

The admissible load of suspension components and their fasteners shall be tested in accordance with 5.3, unless the dimensions, nature and design of the material allow load bearing capacity and deformation to be calculated.

The admissible load shall be declared.

4.3.3.2 Timber suspension components

Timber suspension components shall either have a minimum cross section of 1 000 mm² and a minimum thickness of 20 mm, provided that a sufficiently secure connection (i.e. the timber cross section has to be enlarged when the force to be transmitted is larger than the minimum cross section allows) can be achieved by using nails or screws, or their strength shall be calculated according to EN 1995-1-1.

The admissible load shall be declared.

4.3.4 Resistance to fixings

Where and as far as relevant, manufacturers shall ensure that products withstand the loads that may be expected load, in accordance with 5.3.

4.3.5 Wind load resistance

Where the suspended ceiling is expected to be subject to interior wind load (e.g. in case of opening windows, doors), all necessary design measures shall be taken to enable the membrane components and the substructure to resist upward and/or downward load.

Under interior wind loading conditions, the ceiling membrane and substructure shall retain their stability and integrity and although some deformations could be acceptable, suspended ceilings or their parts shall be designed not to fail nor to collapse under this action.

In all other cases (circumstances) particularly buildings with large or permanent (e.g. parking houses) openings or in colonnades and open access ways the acceptance of wind loads (pressure/suction) by the suspended ceiling shall be proved, e.g. by calculation according to EN 1991-1-4.

NOTE For further information, see Annex C.

4.3.6 Impact resistance

Where the suspended ceiling is required to resist impact (e.g. in sports halls caused by ball throwing), the nature of the activity shall be ascertained and the required performance specified (e.g. classification of ball throwing resistance). The suspended ceiling shall be designed accordingly.

Where required, the impact resistance shall be tested according to Annex D.

The class of impact velocity under which the test ceiling withstands the impact without adversely affecting the strength, the function and safety of the suspended ceiling and which does not lead to a significant change in appearance shall be declared.

4.3.7 Seismic resistance

Where the suspended ceiling is exposed to seismic shocks, EN 1998-1 shall be taken into consideration. The suspended ceiling shall be designed such that the vertical and horizontal actions caused by seismic impacts do not cause damage or collapse.

4.4 Safety in case of fire

4.4.1 Fire resistance

4.4.1.1 General

Where fire resistance of suspended ceiling kits is required, EN 13501-2 shall be used for classification purposes in accordance with Decision 2000/367/EC⁴⁾, based on a test done in accordance with procedures described in the following subclauses.

NOTE Some Member States may have limitations on the use of demountable suspended ceilings for fire resistant uses.

4.4.1.2 Test specimen preparation

The suspended ceiling to be tested shall be representative of the complete ceiling system (suspension, substructure, membrane, etc.) for which the fire resistance rating is required.

In addition, the specific provisions of the test standard(s) called up by EN 13501-2 shall be followed.

4.4.1.3 Testing and classification

Suspended ceilings shall be tested in end use conditions and classified in accordance with EN 13501-2. Suspended ceilings having fire resistant performance shall be classified in one of the following three ways:

- Ceilings with fire resistance in conjunction with the element (e.g. floor or roof) above. Such ceilings shall be tested in conjunction with the roof/floor assembly above and fire resistance classification shall be related to the whole assembly.
- Ceilings which possess a fire resistant property independent of any element. The classification shall separately cover those ceilings that have a fire resistance performance from above and/or below independent of any element above the ceiling.
- As horizontal protective membranes.

4.4.2 Reaction to fire

4.4.2.1 General

Where use of suspended ceilings is subject to regulatory reaction to fire requirements, reaction to fire testing and classification shall be based on the performance of each component making up the ceiling (i.e. material-based testing approach), which shall be stated separately in the results. Where a substructure kit, substructure component or membrane component are sold separately, these are also subject to testing and classification.

For suspended ceilings placed on markets of some countries outside European Economic Area, where a full-scale testing approach is required, the suspended ceiling may be tested according to the provisions valid therein.

Where regulatory requirements exist, ceiling membrane components and substructure components shall be tested and classified in accordance with EN 13501-1 and the conditions described below, or they may be classified as reaction to fire Class A1⁵⁾ without the need for testing (CWT) or they may be classified without

4) Decision 2000/367/EC (OJEU L133 of 6.6.2000) amended by Decision 2003/629/EC (OJEU L218 of 30.08.2003).

5) See Decision of the Commission 96/603/EC of 1996-10-04 (see OJEU L267 of 1996-10-19), as amended twice by 2000/605/EC of 2000-09-26 (see OJEU L258 of 2000-10-12) and by 2003/424/EC of 2003-06-06 (see OJEU L144 of 2003-06-12).

the need for further testing (CWFT) in accordance with the appropriate agreed CWFT cases, as specified in Annex K.

Where the ceiling membrane and/or the substructure components have already been classified for reaction to fire in accordance with the provisions of EN 13501-1 and the prescriptions below (e.g. by conforming to a relevant product standard), the ceiling producer may use such classification of the ceiling membrane and/or the substructure components without the need to repeat the tests, provided that sufficient checks are in place to ensure the identification of the product.

4.4.2.2 Membrane components

The following possible options in relation to ceiling membranes may exist:

- a) the membrane is intended to be used as it is, with no addition of products above it when installed;
- b) the membrane is placed onto the market together with an insulation or other material to be installed above or below the membrane.

In case a), the ceiling membrane component shall be tested and classified on its own. In case b), the membrane component shall be tested together with an insulation or other material.

Where regulations require, the ceiling shall be tested either from the underside only (i.e. the side facing the room) or from the underside and top side (i.e. the side facing the ceiling void). Where this leads to different classifications, these shall be indicated in the results. Membrane components shall be mounted and fixed according to Annex I.

4.4.2.3 Substructure kits and substructure components

When testing substructure components in the SBI apparatus according to EN 13823, either they shall be mounted and fixed according to Annex I and tested in a way that permits their class to be determined in an appropriate way, or the class of the substructure material itself (e.g. timber or plastic) may be determined.

When testing substructure components in the small flame test apparatus according to EN ISO 11925-2, either they shall be mounted and tested in a way that permits their class to be determined in an appropriate way, or the class of the substructure material itself (e.g. timber or plastic) may be determined.

4.4.2.4 Jointing products

Where use of suspended ceilings is subject to regulatory requirements, the reaction to fire performance of jointing products shall be classified according to EN 13501-1.

Where a component or material is used, and its reaction to fire class, according to EN 13501-1, has already been determined (e.g. by compliance with harmonized European technical specification), this class may be used for declaring the reaction to fire classification of the prefabricated element according to this European Standard without the need of re-testing it.

Furthermore, the reaction to fire class of the component or material may be declared without the need for further testing (CWFT) according to relevant table in Annex K, if it meets all the requirements of that particular class given therein or where a higher class than the one in CWFT is sought.

Likewise, the reaction to fire class of such component or material may also be declared without the need for testing (CWT) as Class A1, if it meets all the requirements for such materials or products (see footnote 5)).

4.5 Hygiene, health and environment – Toxic gases and dangerous substances

4.5.1 Release of Asbestos (content)

No part of a ceiling shall release and/or contain asbestos. The indication "No content" shall be declared.

4.5.2 Release and/or content of formaldehyde

Where formaldehyde-containing material is added to any of the components of the ceiling as a part of the production procedure, the component shall be tested and classified into one of two classes: E1 or E2. The classes and related test methods shall be as specified in Annex E.

This requirement does not apply to components having naturally occurring levels of formaldehyde, which may be classified E1 without the need for testing.

Components, which have neither formaldehyde containing materials added nor which have naturally formaldehyde levels occurring do not have to be classified and declared in respect of formaldehyde release.

4.5.3 Other dangerous substances

National regulations on dangerous substances, other than those already covered in other clauses of this standard, may require verification and declaration on release, and sometimes content, when construction products covered by this standard are placed on those markets.

In the absence of European harmonized test methods, verification and declaration on release/content should be done taking into account national provisions in the place of use.

NOTE An informative database covering European and national provisions on dangerous substances is available at the Construction web site on EUROPA accessed through: <http://ec.europa.eu/enterprise/construction/cpd-ds/>.

4.5.4 Susceptibility to the growth of harmful micro-organisms

Some products covered by this standard may be susceptible to the growth of harmful micro-organisms. Given the absence of a European evaluation method, manufacturers should inform contractors and/or users of this susceptibility in accordance with Table 7.

Table 7 — levels of susceptibility

Level	Susceptibility
A	Not susceptible
B	Susceptible

In accordance with 4.8.1 and 4.10, thermal insulation/dew-point calculations, in accordance with EN ISO 6946 and EN ISO 10211, shall be made to demonstrate that the conditions producing such effects are avoided.

4.6 Safety in use

4.6.1 Shatter properties

Where membrane components are made of materials for which shatter properties or safe breakage are required (e.g. glass), the performance of the membrane in case of shattering or breakage shall be determined, classified and declared according to EN 12600.

4.6.2 Flexural tensile strength

The membrane shall have sufficient strength to support its own mass when installed in the substructure. When any additional load is to be applied, the load which may be applied shall be specified. In addition to the minimum requirement that the membrane shall not fall out, it shall be of adequate strength to ensure that safety in use is maintained. Relevant, adequate flexural tensile strength shall be determined, due account being taken of the span of the membrane component, any openings which may be made in it, and any load (in addition to its self weight) that may be attached to the membrane. Tests designed to assess the flexural tensile strength shall be performed according to Annex F, on representative samples of the membrane material, account also being taken of the end use design. The result of the test and the performance of the membrane shall be declared as one of the classes of exposure of Table 8 and the admissible type of load to be applied according to Table F.2.

4.6.3 Mechanical strength, safety against failure – baffles

Testing for flexural tensile strength is not applicable to baffles. The mechanical strength and safety against failure of baffles shall be determined according to Annex J. Whether or not the baffles meet the requirement shall be expressed as "pass" or "fail".

4.6.4 Electrical safety

Where relevant, suspended ceilings shall be capable of allowing installation of electrical appliances without risk of electrocution.

Where required, suspended ceilings shall be designed so that electrical wiring can be carried in exposed or concealed trays specifically designed and installed for that purpose.

Where regulations require that the suspended ceiling is earthed and/or bonded, the ceiling and its components shall be designed to allow this, in accordance with the requirements valid in the intended place of use of the product. Manufacturers shall declare whether the suspended ceiling is safe against the risk of electrocution and is designed (or is not designed) including earthing or bonding.

4.7 Acoustics

4.7.1 Test specimen preparation

Where acoustic performance is to be declared, the suspended ceiling to be tested shall be representative of the ceiling to be used in practice and for which the acoustic rating is required. In addition, the specific provisions of the test standard(s) listed below shall be followed.

Designers should be aware that the laboratory test results will not necessarily be reproduced on site (see EN 12354-6). For special applications or special acoustical performances studies, laboratory tests and in situ tests may be required.

4.7.2 Sound absorption

Where required, suspended ceilings having a sound absorption property shall be used and their sound absorption coefficients established according to EN ISO 354 and declared. The sound absorption coefficients shall be calculated as practical sound absorption coefficient α_p , expressed in a diagram or a table in octave bands, and into a single value α_w with shape indicator in accordance with EN ISO 11654.

NOTE Sound absorption is the reduction of sound energy that occurs when sound waves are absorbed by building surfaces and elements. The amount of sound absorption required and the location of the sound absorbing surfaces depend on a number of factors. These include the intended use of the room, the nature of the noise generated, the need to control reverberation, the shape of the room and the reflective characteristics of the enclosing surfaces.

The required reverberation time is function of the quantity and the performance of the absorption material and the shape and volume of the room (see EN 12354-6).

4.7.3 Sound insulation

4.7.3.1 General

Sound insulation concerns the acoustic performance of building elements in relation to their effect on the transmission of airborne and impact sound in a building. A suspended ceiling system may be required to:

- assist structural floors in reducing the vertical transmission of airborne and impact sound through the floor (vertical transmission);
- reduce the sound transmission from room to room. This relates to both direct and indirect sound and is of particular importance where suspended ceilings are carried over partitions (horizontal transmission).

Where the suspended ceiling is required to contribute to the reduction of the vertical transmission of airborne and impact sound through a floor, and/or where the suspended ceiling is required to contribute to the reduction of direct and indirect horizontal sound transmission (including the situation where the suspended ceiling with a plenum crosses over partitions), the performance shall be measured and expressed as described in 4.7.3.2 and 4.7.3.3, respectively.

4.7.3.2 Laboratory measurement of vertical sound reduction

The laboratory measurement of vertical sound reduction of airborne sound shall be in accordance with EN ISO 10140 and declared in accordance with EN ISO 717-1.

4.7.3.3 Laboratory measurement of horizontal transmission

The laboratory measurement of horizontal sound reduction of a suspended ceiling with a plenum above it shall be in accordance with EN ISO 10848-2 and declared in accordance with EN ISO 717-1.

4.7.4 Direct field of application

The results of acoustic tests may be extended to other ceilings of similar design, without the need for re-testing, subject to the following conditions:

- any change shall demonstrably lead to an improvement in acoustic performance (e.g. increased thickness of the membrane, increased density or greater dynamic stiffness);
- changes to the area shall be permitted, subject to the condition given above;
- components and membranes from one manufacturer may be changed to those from another manufacturer having the same or improved acoustic specification.

4.8 Durability

4.8.1 General

Products meeting the requirements specified in this clause may be deemed to satisfy the expected economical lifetime for easily replaceable products.

The exposure class in accordance with Table 8 shall be declared.

4.8.2 Dampness

Suspended ceilings shall be designed to ensure that detrimental levels of water and condensation are not formed within or on the surfaces of the ceiling and adjacent building components, during the intended working life of the ceiling, in ways which could lead to a loss of flexural tensile strength of the membrane and/or loss of load bearing capacity of the whole suspended ceiling kit or the substructure. Thermal insulation/dew-point

calculations, in accordance with EN ISO 6946 and EN ISO 10211, shall be made to verify and demonstrate that the conditions producing such effects are avoided.

The level of protection against corrosion of steel and aluminium components when exposed in the range of exposure conditions given below shall be specified in accordance with Table 9. For the protection of timber, 4.3.2.2.3 shall apply.

4.8.3 Service life requirements

The suspended ceiling shall retain its performance properties during its service life when exposed to the conditions for which it was designed (see 4.8.4), subject to receiving normal maintenance, as recommended by the designer, and not subject to ill treatment during its life.

The following information relating to durability and maintenance shall be provided as indicated:

- the ceiling manufacturer shall state if the visible surfaces of the ceiling membrane and substructure are cleanable and, if so, what cleaning technique is required and what limitations apply;
- the ceiling manufacturer shall state if the visible surface of the ceiling membrane and substructure is re-paintable and, if so, what materials and techniques are recommended and what, if any, aspects of the ceiling's performance would be affected;
- the ceiling manufacturer shall state the likely effect of the cleaning and painting on other aspects of the performance of the ceiling;
- the ceiling manufacturer shall state the minimum maintenance requirements necessary to enable the ceiling to continue to meet its claimed performance during its working life.

4.8.4 Classification of ceiling exposure conditions

The ceiling or component manufacturer shall state which of the classes of exposure of Table 8 the suspended ceiling or component complies with the requirements of 4.6.2 and 4.8.3.

Table 8 — Classes of exposure

Class	Conditions
A	Building components exposed to varying relative humidity up to 70 % and varying temperature up to 25 °C but without corrosive pollutants
B	Building components exposed to varying relative humidity up to 90 % and varying temperature up to 30 °C but without corrosive pollutants
C	Building components exposed to varying relative humidity up to 95 % and varying temperature up to 30 °C and accompanied by a risk of condensation but without corrosive pollutants
D	More severe than the above

4.8.5 Corrosion protection

Metal framing components, suspensions and connecting elements shall be protected against corrosion according to Table 9.

Table 9 — Classes of corrosion protection of metal substructure components and membrane components

Class (according to Table 8)	Profiles, suspensions, connecting elements and membranes	
	Components made of steel	Components made from aluminium
A	Products with a continuously hot-dip metal coating Z100, ZA095 or AZ100 according to EN 10346 ^{a,b} . Products with electroplated zinc coating flat ZE25/25 according to EN 10152 ^b . Continuously organic coated (coil-coated) products of corrosion protection (interior) category CPI2 for the exposed side according to EN 10169 ^e (e.g. coating system ZE15/15-HDP25-2T-CPI2).	No additional corrosion protection required
B	Products with a continuously hot-dip metal coating Z100, ZA095 or AZ100 according to EN 10346 ^{a,b} . Products with electroplated zinc coating flat according to EN 10152 with or without an additional organic coating ^c as follows ^b : ZE25/25 + 40 µm per face ^d , ZE50/50 + 20µm per face ^d or ZE100/100 without OC. Continuously organic coated (coil-coated) products of corrosion protection (interior) category CPI2 for the exposed side according to EN 10169 ^e (e.g. coating system ZE15/15-HDP25-2T-CPI2).	No additional corrosion protection required or coil coating according to EN 1396:2007: corrosion index 2a
C	Products with a continuously hot-dip metal coating Z100, ZA095 or AZ100 according to EN 10346 ^{a,b} with an additional organic coating ^c of 20 µm per face. Products with electroplated zinc coating flat according to EN 10152 with an additional organic coating ^c as follows ^b : ZE25/25 + 60 µm per face ^d , ZE100/100 + 40µm per face.	Anodizing ^b (15 µm < s < 25 µm) or coil coating according to EN 1396:2007: corrosion index 2a
D	Special measures depending on use and corrosion action. Minimum corrosion protection according to Class C. Additional measures as required.	Anodizing ^b (s > 25 µm) or coil coating according to EN 1396:2007: corrosion index 2b

^a EN 10327 replaces EN 10142 (Zinc), EN 10214 (Zinc - Aluminium) and EN 10215 (Aluminium - Zinc) and EN 10346 replaces EN 10327.
^b Any equivalent corrosion protection leading to a similar level of protection is permitted.
^c Coating of exposed parts with zinc compatible organic coating according to EN ISO 12944-3 applied by a post-painting process or equivalent coil coating according to EN 10169.
^d Applies only to membrane components.
^e Applies only to "capping" material for substructure components.

4.8.6 Contact corrosion protection

In order to avoid corrosion due to contact between dissimilar materials (e.g. steel and aluminium), intermediate layers of suitable protecting materials shall be applied according to EN ISO 12944-3.

Where wood preservatives are used, the corrosion protection method for the metal components that are connected to the timber components shall be compatible with the wood preservative.

4.8.7 Durability of non-cellular PVC profiles

The durability of non-cellular PVC-U profiles shall be demonstrated by testing the impact resistance at 23 °C according to EN 13245-1:2010, Annex A, and declaring the result according to EN 13245-1:2010, Table 2. The durability of PVC-UE profiles shall be demonstrated by testing the impact resistance at 23 °C according to EN 13245-2:2008, Annex B, and declaring the result according to EN 13245-2:2008, Table B.1.

4.8.8 Durability of wooden products

With regards to biological durability of timber, the hazard classes in which a product may be used are specified in EN 335. Alternatively, an appropriate preservation treatment shall be chosen in accordance with EN 350, EN 351 and EN 460. The mechanical durability shall be determined by taking the appropriate modification factors k_{mod} and k_{def} from EN 1995-1-1.

4.9 Colour, light reflectance and gloss factor for suspended ceiling components

4.9.1 General

Colours, light reflectance and gloss factor shall be as agreed between designer and specifier and, where required, shall be tested and declared according to 4.9.2, 4.9.3 and 4.9.4.

NOTE The number of colour tests is left to the discretion of the designer.

4.9.2 Measurement method of colour composition

The colour composition of suspended ceiling components shall be measured using a computerized measuring device, operating according to the CIE-Lab method in ISO 7724-2 and ISO 7724-3.

4.9.3 Measurement method for light reflectance

The light reflectance value of suspended ceiling components shall be measured using a computerized measuring device, operating according to the CIE-Lab method in ISO 7724-2 and ISO 7724-3. The designer shall state what, if any, the effect of perforations of the components is on the recorded light reflectance value.

4.9.4 Measurement and value of gloss factor

The gloss factor of suspended ceiling components shall be determined and classified in accordance with EN ISO 2813.

4.10 Thermal insulation

Where the suspended ceiling is designed to provide thermal insulation, this shall be demonstrated by calculation using the methods of EN ISO 6946 and EN ISO 10211 with data from one (or both) of the following:

- reference design data, as tabulated values, taken from EN ISO 10456;
- test results (usually where the designer wishes to claim a better performance than obtained from reference design data), using either EN 12664 or EN 12667 with equipment calibrated according to the European level (using IRMM 440 reference material). The declared thermal resistance and/or thermal conductivity shall be calculated using one of the standards EN 13162 through EN 13171:2012, 4.2.1, as appropriate.

The thermal performance of the assembled suspended ceiling kit or component shall be declared.

5 Loading capacity of substructures components – Test methods

5.1 General

This testing method is applicable for metal substructures, suspensions and connecting elements whose loading capacity cannot be determined by calculation.

The specimen to be tested shall include all the characteristics of those products as used on site.

The test results allow determination of the deflection and the admissible loading of the substructure components. This includes various loading configurations, different spans of the profiles and different suspension and connecting components.

The safety factor to be used in Formulae (3b) and (5) for the admissible bending moment and the admissible load shall be 2,5.

5.2 Bending test of metal substructure profiles

5.2.1 General

The load bearing capacity of metal structures shall be determined by the following tests on individual components at various spans and loads.

The bending test relates only to load bearing profiles. The profiles relevant for testing are those which carry the membrane elements and possible additional loads, and which transmit the load to the building structure.

The bending test gives characteristic data of the profiles for:

- bending stiffness EI in $N \cdot mm^2$,
- admissible bending moment $admM$ in $N \cdot m$.

The deflection corresponding to the admissible load and/or admissible moment shall be classified in accordance with Table 6.

Where the membrane components are only supported by perimeter trims (e.g. angle or U-channel), these perimeter trims shall be tested according to Annex H.

5.2.2 Procedure for testing

For preliminary tests, each of 3 sections (i.e. 3 in positive and 3 in negative position) shall be tested as beams on two supports with a point load at mid-span at the maximum design span (max. L) moreover, at a minimum span of:

$$\min L = \max L / 2; \text{ for lengths shorter than } 2,0 \text{ m, } \min L > 1,0 \text{ m} \tag{1}$$

Where perimeter channels are to be tested, a smaller span may be used if this results from the designed distance of the fixing elements (see Figure 14).

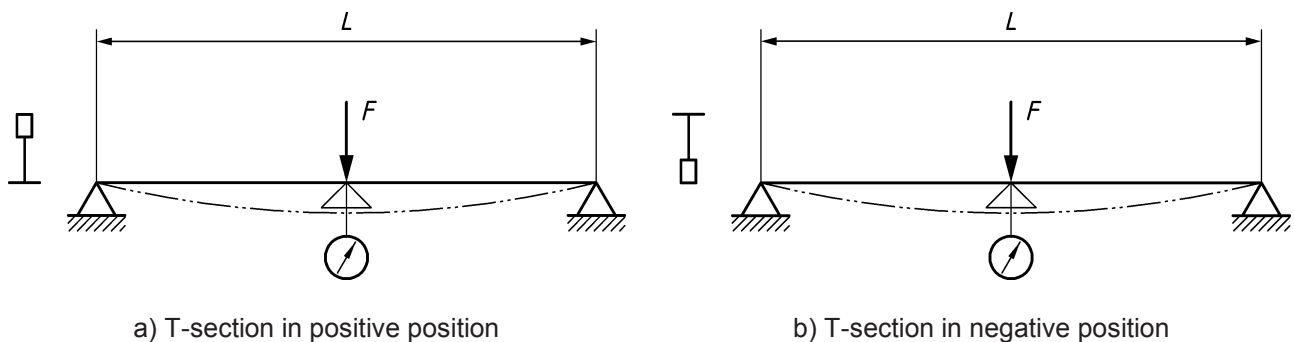

- Key**
- F load
 - L span

Figure 14 — Principle of a bending test of a T-section

Test seven further sections under the conditions of the least favourable case involving the smallest bending moment. The complete test includes 3 samples in 2 positions with each 2 spans (meaning 12 single tests) for preliminary tests and 7 further samples.

The support conditions of the runner/channel shall be selected such that they are in accordance with the conditions in use. The loading point of the profile shall be secured against twisting.

All substructure profiles intended to be used for this test shall have all punching details required for their normal use.

Both the deflection at mid-span measured with gauges with an accuracy of 1/100 mm and at least up to a value equal to the intended deflection class of Table 6 and the corresponding test load (F) shall be determined.

The load shall be temporarily relieved when the deflection reaches the designated class. After removing the load, the permanent deflection shall not exceed 0,2 mm. If this value is exceeded, the designated deflection and the corresponding load shall be reduced. This is to ensure that the load deformation curve is linear-elastic.

The maximum load (F_u) and the corresponding maximum bending moment (M_u) shall be determined.

5.2.3 Assessment of results

The bending rigidity (EI) and the admissible bending moment $admM$ shall be determined from at least 10 tests. The bending rigidity (EI) for a single span beam with a point load in the centre shall be calculated using the following formula:

$$EI = \overline{F}L^3 / 48f_{\max} \quad (2)$$

where

- \overline{F} is the average load of 10 individual tests corresponding to the deflection class, in N (see Table 6);
- L is span of the specimen, in mm;
- f_{\max} is deflection at centre span, in mm;
- E is elasticity modulus, in N/mm²;
- I is moment of inertia, in mm⁴.

It is the linear part of the load-deflection-curve that is relevant for determining the bending rigidity. If the deflection value according to Table 6 is outside this range, the load shall be reduced appropriately.

The admissible bending moment results from two criteria:

The first one relates to the corresponding deflection value and shall be determined by:

$$adm M_f = \overline{M}_f = \overline{F}L/4 \quad (3a)$$

where

\overline{M}_f is the average value of bending moment M_f .

The second value of the admissible bending moment is related to the ultimate load F_u and shall be determined by:

$$adm M_u = M_u^{5\%} / \nu \quad (3b)$$

$$M_u^{5\%} = \overline{M}_u - k_\sigma \cdot s \quad (4)$$

where

- \overline{M}_u is the average value of the bending moment M_u (Nmm) related to the ultimate load F_u ;
- k_σ is a statistical factor (acceptance factor, see 5.4);
- s is the standard deviation, in Nmm;
- $M_u^{5\%}$ is the 5 % fractile;
- ν is the safety factor = 2,5.

The lower value of $\text{adm}M_f$ and $\text{adm}M_u$ shall be used as the definitive value $\text{adm}M$.

If no deflection limit is determined (Class 3), the admissible moment is related to the ultimate load F_u according to Formula (3b).

In the case of other test configurations as described in 5.2.2 (e.g. continuous beams and/or uniformly distributed loads or several point loads) the formula to calculate EI and the bending moment M_f and M_u shall be changed according to the corresponding support and load conditions.

5.2.4 Test report

The test report shall contain at least the following information:

- manufacturer and manufacturing plant;
- identification of the product (description and physical characteristics);
- information about traceability of the products;
- information about sampling:
 - date and time of sampling;
 - production line or unit,
 - personnel involved in sampling;
 - applied sampling method, if any;
- identification of the organization and personnel executing the test;
- applied test method(-s) according the relevant technical specification;
- place and date of testing;
- test results, including analysis of these when relevant:
 - load displacement curves at least up to the designated deflection class;
 - calculated values of the bending rigidity (EI) and the definitive admissible bending moment $\text{adm}M$. If required it shall be stated when the admissible bending moment is outside the linear range of the load-deflection-curve;

- place and date of delivery of the test report;
- registration number of the testing laboratory (when relevant);
- signature of the head of the testing laboratory and stamp.

5.3 Testing of metal suspension and connecting components

5.3.1 General

The suspension test shall include both its connections to the top fixing and to the substructure profile (supporting member, Figure 1). If relevant, preliminary tests may be necessary to clarify whether the suspension itself fails or the failure is between the connection to top fixing (e.g. using a wire with hook or eye to connect the wire with the top fixing (see Figure 15 to Figure 18)) or to the framing member. In Figure 20, an example of a test set up has been presented.

Dimensions in millimetres

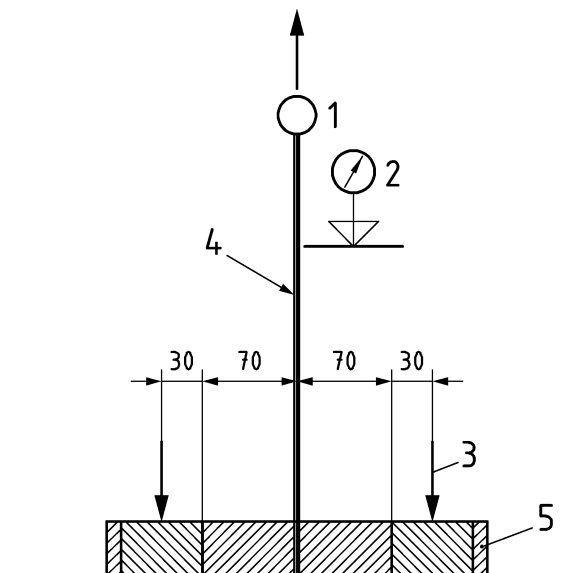

Key

- 1 top fixing
- 2 displacement measurement
- 3 support/ bracing
- 4 suspension (top fixing or substructure profile)
- 5 supporting member

Figure 15 — Principle set-up of suspension test

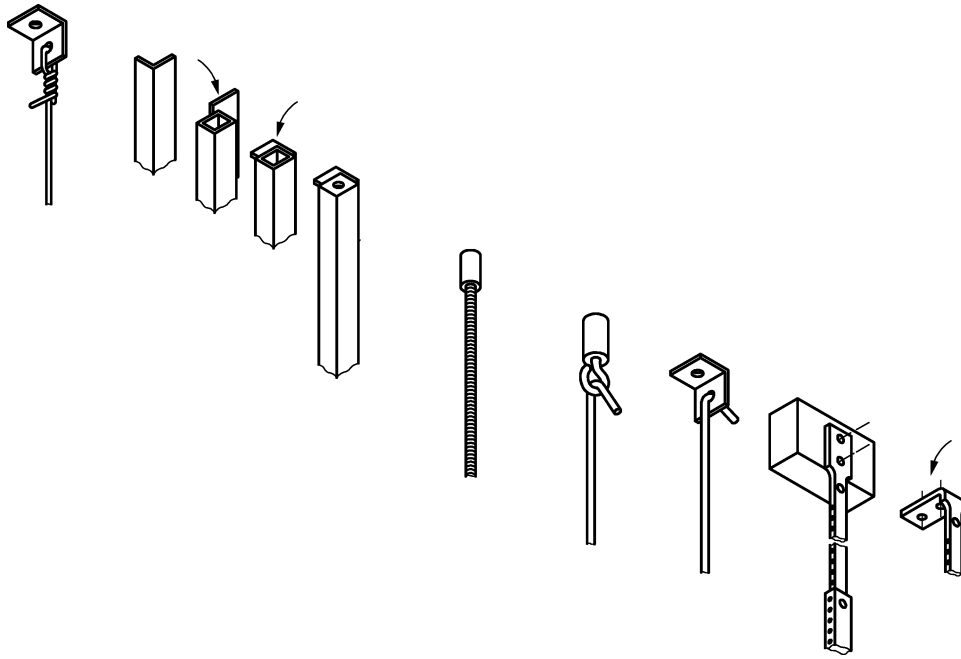

Figure 16 — Examples of different suspension components

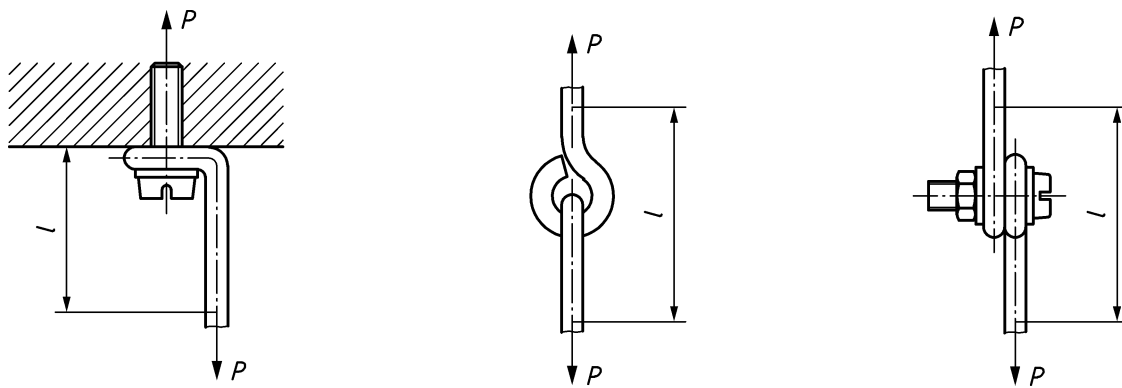

Figure 17 — Examples of different connections between top fixing and suspension

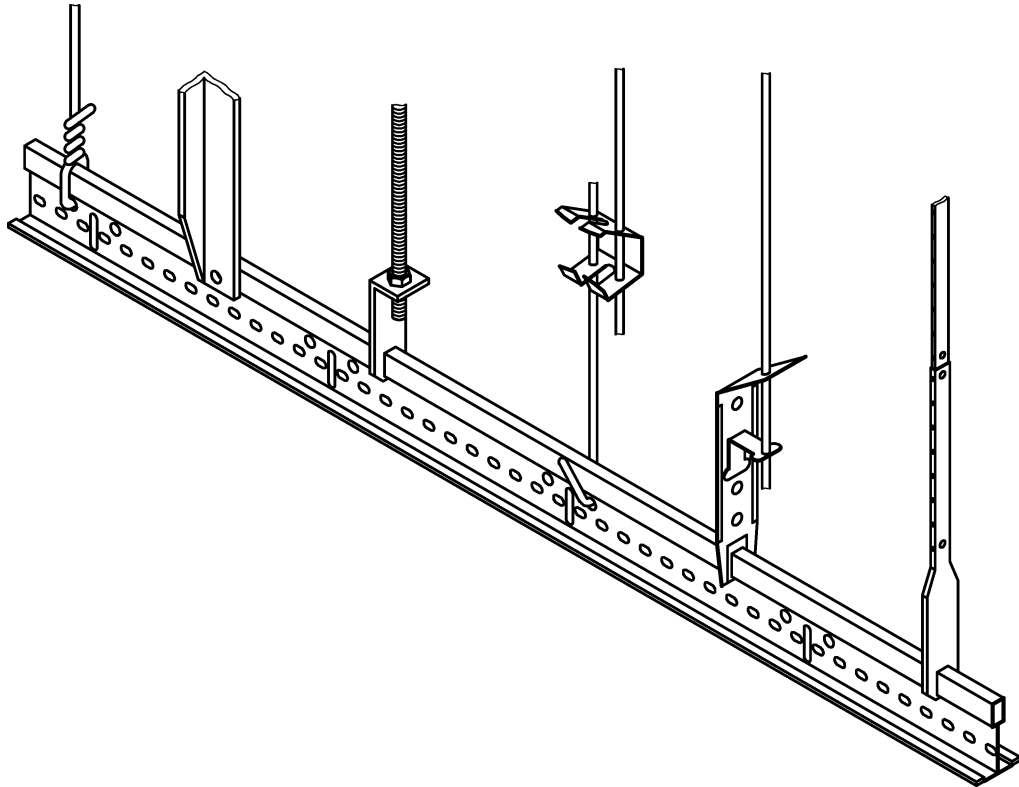
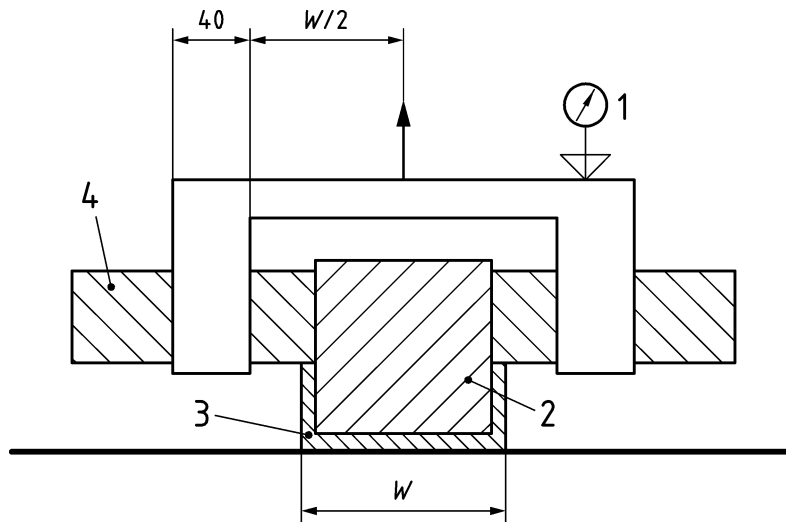

Figure 18 — Examples of different connections between suspension and supporting member

Connecting components (e.g. wire clips, channel connectors, screws) shall be tested in a similar way using the components to be connected (e.g. primary and secondary profile, see Figure 19).

Dimensions in millimetres



Key

- 1 displacement measurement
- 2 profile connector (e.g. cross connector)
- 3 supporting member
- 4 supporting profile
- W width of the connector

Figure 19 — Principle set-up of connector test

The test of the suspension and connecting components in conjunction with the profiles and the top fixing allows the weakest point of the substructure to be determined. This therefore allows the various components (e.g. the suspension itself, its connection to the supporting member and to the top fixing) to be optimized.

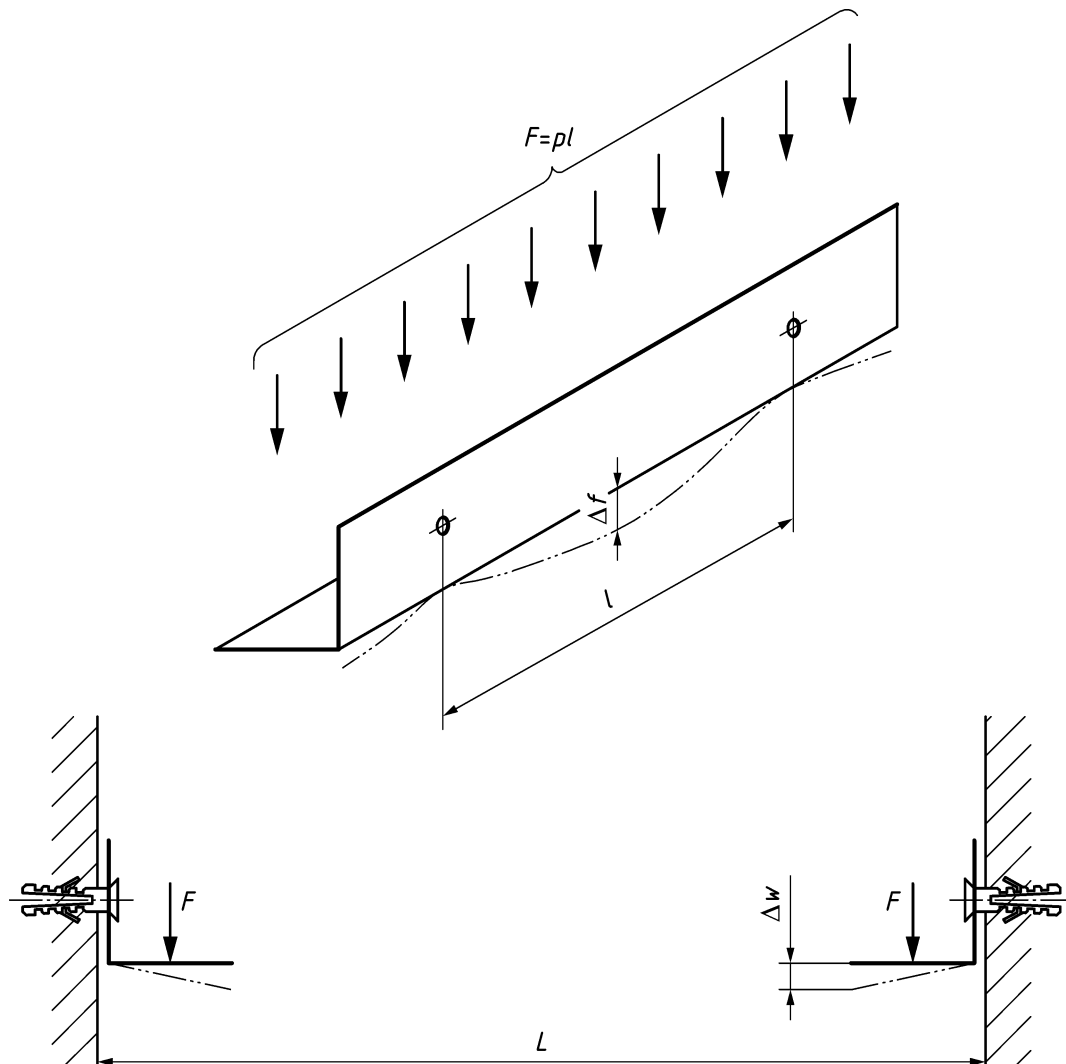

Figure 20 — Example for load bearing perimeter trim

5.3.2 Static test

5.3.2.1 General

The tensile test as mentioned in 5.3.1 shall be carried out on 3 individual samples (components) fitted in the same way as in practice in a ceiling structure, including the connection to the top fixing as well as to the supporting member.

The test configuration shall be selected such that the largest displacement of the loading point and the minimum load capacity is to be expected. Diagonal pull or bending may need to be taken into account.

For suspension components designed to be subjected to compression, the tests shall be carried out under compressive load in which the length of the suspension component has to be taken into account.

5.3.2.2 Test for suspension components

The test conditions shall express standard laboratory conditions.

Load rate: A preliminary test shall take place until failure or intended deformation. The load determined shall then be divided by 20. The value established in this way shall then be considered as steps to increase the load in the official test.

Measurements taken and recorded shall be load and displacement.

Number of test samples subjected to testing shall be 3 per suspension component type.

5.3.2.3 Test for connecting components

The test conditions shall express standard laboratory conditions.

Load rate: A preliminary test shall take place until failure or intended deformation. The load determined shall then be divided by 20. The value established in this way shall then be considered as steps to increase the load in the official test.

Measurements taken and recorded shall be load and displacement.

Number of test samples subjected to testing shall be 3 per connector type.

5.3.3 Functional test

When a suspension component (e.g. hanger, connector) is used in a suspended ceiling exposed to wind load as described in 4.3.5 last paragraph, a functional test of the suspension component shall be carried out according to Annex G.

5.3.4 Assessment of test results (static test)

The admissible load ($admF$) shall be determined from the results of not less than 3 individual tests using the Formulae:

$$adm F = F_u^{5\%} / \nu \quad (5)$$

$$F_u^{5\%} = \overline{F}_u - k_\sigma \cdot s \quad (6)$$

where

\overline{F}_u is average value of ultimate load F_u , in N;

k_σ is statistical factor (acceptance factor, see 5.4);

s is the standard deviation, in N;

$F_u^{5\%}$ is the 5 % fractile;

ν is the safety factor = 2,5.

The displacement of the loading point corresponding to $admF$ shall be stated as:

\overline{f} average value of displacement, in mm;

f_{min} minimum value of displacement, in mm;

f_{max} maximum value of displacement, in mm.

5.3.5 Test report

The test report shall contain at least the following information:

— manufacturer and manufacturing plant;

- identification of the product (description and physical characteristics);
- information about traceability of the products;
- information about:
 - date and time of sampling;
 - production line or unit;
 - personnel involved in sampling;
 - applied sampling method, if any;
 - test configuration and point of deflection measurement, details on measurements, illustrations and photographs;
- identification of the organization and personnel executing the test;
- place and date of testing;
- test results, including analysis of these when relevant:
 - load displacement up to the failure of the suspension component;
 - admissible load with the three displacement values;
 - place and date of delivery of the test report;
 - registration number of the testing body (where relevant);
 - signature of the head of the testing laboratory and stamp.

5.4 Acceptance factor k_{σ}

The basis for the k_{σ} value is the assumption of a random test with an unknown standard deviation of the result.

The acceptance factor k_{σ} shall be taken from Table 10.

NOTE k_{σ} depends on the number n of test samples (normally is $n = 10$). The minimum number of n is 3. It follows from this that $\nu = n - 1$ starts with 2.

Table 10 — Acceptance factor k_{σ}

Fractile ϕ	$\nu = n - 1$												
	Number of test specimens												
	2	3	4	5	6	7	8	9	10	11	12	13	14
$W = 0,90$ 5%	5,31	3,96	3,40	3,09	2,89	2,75	2,65	2,57	2,50	2,45	2,40	2,36	2,33

NOTE 1 Values for k_{σ} depending on the number of test samples n , the probability (W) and the fractile value ϕ (assumption: the standard deviation is unknown).

NOTE 2 For this standard, the probability W and the fractile value ϕ have been fixed at 0,90 and 5 %, respectively. For $n = 10$ test pieces, the prevailing k_{σ} value is 2,57.

6 Evaluation of conformity

6.1 General

The compliance of the product (i.e. membrane, individual substructure components, substructure kit and/or suspended ceiling kit) with the requirements of this European Standard shall be demonstrated by:

- initial type testing;
- factory production control by the manufacturer, including the product's assessment.

The rest of the text in the following sub clauses uses the term "component" to mean 'finished product'. This should be replaced by 'kit' when dealing with kits.

The manufacturer shall ensure:

- that the initial type testing in accordance with this European Standard is initiated and carried out, and
- that the component continuously complies with the declared performance, for which compliance with this European Standard has been verified.

Initial type testing as covered by 6.2 also includes evaluation by calculation.

The manufacturer is fully responsible for the conformity of that component with this European Standard. However, where the manufacturer uses components already shown to comply with the requirements relevant for that component (e.g. by CE marking) the manufacturer is not required to repeat the evaluation which lead to such compliance. Where the manufacturer uses components not shown to comply, it is his responsibility to undertake the necessary evaluation to show compliance.

NOTE For information on which systems of attestation of conformity apply for CE marking purposes, see ZA.2.1.

6.2 Initial type testing

6.2.1 Initial type testing shall be performed to demonstrate conformity with this European Standard.

All characteristics given in 4.1, 4.2, 4.3.2, 4.3.3, 4.3.4, 4.3.6, 4.4.1, 4.4.2.1, 4.4.2.2, 4.4.2.3, 4.4.2.4, 4.5, 4.6.1, 4.6.2, 4.6.3, 4.6.4, 4.7.2, 4.7.3, 4.8 and 4.10 shall be subject to this initial type testing, except as described in 6.2.3 to 6.2.4.

6.2.2 In the case of modification of the component or of the method of production (where these may affect the declared performances), initial type testing shall be performed. All characteristics given in 4.1, 4.2, 4.3.2, 4.3.3, 4.3.4, 4.3.6, 4.4.1, 4.4.2.1, 4.4.2.2, 4.4.2.3, 4.4.2.4, 4.5, 4.6.1, 4.6.2, 4.6.3, 4.6.4, 4.7.2, 4.7.3, 4.8 and 4.10, which may be changed by the modification, shall be subject to this initial type testing, except as described in 6.2.3 to 6.2.4.

6.2.3 Tests previously performed in accordance with the provisions of this standard may be taken into account for the ITT purpose, providing that they were made in accordance with the provisions of this standard under the same system of attestation of conformity on the same component or components of similar design, construction and functionality, such that the results are applicable to the component in question, with the exception of tests performed in accordance with previous versions of test standards for acoustical performances (see 4.7), which can still be used to calculate the single value performances based on existing test reports, if correlation with the newest versions of the test method standards can be established and the single value performances adapted accordingly.

6.2.4 Components may be grouped into families where one or more characteristics are the same for all components within that family or the test results are representative of all components within that family. In this case, not all components of the family have to be tested for the purposes of the initial type testing.

6.2.5 Test samples shall be representative of the component. If the test samples are pre-production components, they shall be representative of the intended future component.

6.2.6 Any initial type testing and its results shall be documented in a test report.

6.3 Factory production control (FPC)

6.3.1 General

The manufacturer shall establish, document and maintain a FPC system to ensure that the components placed on the market conform to the declared performance characteristics.

If the manufacturer has the component designed, manufactured, assembled, packed, processed and labelled by subcontracting, FPC of the original manufacturer may be taken into account. However, where subcontracting takes place, the manufacturer shall retain the overall control of the component and ensure that he receives all the information that is necessary to fulfil his responsibilities according to this European Standard. The manufacturer who subcontracts all of his activities may in no circumstances discharge himself of his responsibilities to a subcontractor.

FPC is the permanent internal control of production exercised by the manufacturer.

All the elements, requirements and provisions adopted by the manufacturer shall be documented in a systematic manner in the form of written policies and procedures. This production control system documentation shall ensure a common understanding of conformity evaluation and enable the achievement of the required component characteristics and the effective operation of the production control system to be checked.

Factory production control therefore brings together operational techniques and all measures allowing maintenance and control of the conformity of the component with its technical specifications. Its implementation may be achieved by controls and tests on measuring equipment, raw materials and constituents, processes, machines and manufacturing equipment and finished components, including material properties in components, and by making use of the results thus obtained.

6.3.2 General requirements

A FPC system shall be used. The requirements as described in the following clauses of EN ISO 9001:2008 shall be fulfilled, where applicable:

- 4.2 except 4.2.1 a),
- 5.1 e), 5.5.1, 5.5.2,
- Clause 6,
- 7.1 except 7.1 a), 7.2.3 c), 7.4, 7.5, 7.6,
- 8.2.3, 8.2.4, 8.3, 8.5.2.

NOTE Manufacturers having an FPC system, which complies with EN ISO 9001 and which addresses the requirements of this European standard are recognized as satisfying the FPC requirements of the Council Directive 89/106/EEC.

6.3.3 Product specific requirements

6.3.3.1 The FPC system shall:

- address this European Standard, and

— ensure that the components placed on the market conform to the declared performances.

6.3.3.2 The FPC system shall include a component specific FPC- or quality-plan, which identifies procedures to demonstrate conformity of the component at appropriate stages, i.e.:

- a) the controls and tests to be carried out prior to and/or during manufacture according to a frequency laid down in Tables 11 to 13, as applicable; and/or
- b) the verifications and tests to be carried out on finished components according to a frequency laid down in Tables 11 to 13, as applicable.

If the manufacturer uses finished components, the operations under b) shall lead to an equivalent level of conformity of the component as if FPC had been carried out during the production.

If the manufacturer carries out parts of the production himself, the operations under b) may be reduced and partly replaced by operations under a). Generally, the more parts of the production that are carried out by the manufacturer, the more operations under b) may be replaced by operations under a). In any case, the operation shall lead to an equivalent level of conformity of the component as if FPC had been carried out during the production.

NOTE Depending on the specific case, it may be necessary to carry out the operations referred to under a) and b), only the operations under a) or only those under b).

The operations under a) centre as much on the intermediate states of the component as on manufacturing machines and their adjustment, and test equipment, etc. These controls and tests and their frequency are chosen based on component type and composition, the manufacturing process and its complexity, the sensitivity of component features to variations in manufacturing parameters, etc.

The manufacturer shall establish and maintain records that provide evidence that the production has been sampled and tested. These records shall show clearly whether the production has satisfied the defined acceptance criteria. Where the component fails to satisfy the acceptance measures, the provisions for non-conforming products shall apply, the necessary corrective action shall immediately be taken and the components or batches not conforming shall be isolated and properly identified. Once the fault has been corrected, the test or verification in question shall be repeated.

The results of controls and tests shall be properly recorded. The component description, date of manufacture, test method adopted, test results and acceptance criteria shall be entered in the records under the signature of the person responsible for the control/test. With regard to any control result not meeting the requirements of this European Standard, the corrective measures taken to rectify the situation (e.g. a further test carried out, modification of manufacturing process, throwing away or putting right of the component) shall be indicated in the records.

Each component of a kit shall comply with Tables 12 and 13, as relevant.

Ancillary products shall be checked with a sufficient frequency to ensure that the ceiling kit maintains its declared performance.

Table 11 — Minimum testing frequencies for membrane components, using direct or indirect testing or assessment

Characteristics	Direct testing		Indirect testing or assessment	
	Test method	Frequency	Test method	Frequency
Reaction to fire: (CWT or CWFT)	-	-	Manufacturer's method to determine organic content and/or verification of supplier's declaration	Each delivery of incoming materials
Reaction to fire: classification through testing	-	-	Manufacturer's method to determine organic content for all constituents influencing the RtF-performance and/or verification of supplier's declaration	Once every 8 h and/or each delivery of incoming materials
Dangerous substances	-	-	As appropriate	As appropriate
Release of formaldehyde	-	-	Manufacturer's method and/or verification of supplier's declaration	Once every 8 h and/or each delivery of incoming materials
Shatter properties (only brittle products, e.g. glass)	-	-	Manufacturer's method and/or verification of supplier's declaration	Once every 8 h and/or each delivery of incoming materials
Flexural tensile strength	-	-	Manufacturer's method and/or verification of supplier's declaration	Once every 8 h and/or each delivery of incoming materials
Sound absorption	-	-	Manufacturer's method and/or verification of supplier's declaration	Once every 8 h and/or each delivery of incoming materials
Thermal conductivity	4.10	Once every day ^a	Manufacturer's method and/or verification of supplier's declaration	Once every 8 h and/or each delivery of incoming materials
Durability- Metal membrane components	-	-	Manufacturer's method and/or verification of supplier's declaration	Once every 8 h and/or each delivery of incoming materials
Durability- Other materials	Relevant product standard	Once every 8 h	Manufacturer's method and/or verification of supplier's declaration	Once every 8 h and/or each delivery of incoming materials
Dimensions, shapes and tolerances	Relevant test method	-	Manufacturer's method and/or verification of supplier's declaration	Once every 2 h and/or each delivery of incoming materials

^a For thermal insulating products, once every day or once every three months and indirect testing.

Table 12 — Minimum testing frequencies for substructure components (profiles, connecting and suspension elements), using direct or indirect testing or assessment

Characteristics	Direct testing		Indirect testing or assessment	
	Test method	Frequency	Test method	Frequency
Reaction to fire: (CWT or CWFT)	-	-	Manufacturer's method to determine organic content and/or verification of supplier's declaration	Each delivery of incoming materials
Reaction to fire: classification through testing	-	-	Manufacturer's method to determine organic content for all constituents influencing the RtF-performance and/or verification of supplier's declaration	Once every 8 h and/or each delivery of incoming materials
Dangerous substances	-	-	As appropriate	As appropriate
Release of formaldehyde, when relevant			Manufacturer's method and/or verification of supplier's declaration	Once every 8 h and/or each delivery of incoming materials
Load bearing capacity	-	-	Manufacturer's method and/or verification of supplier's declaration	Once every 8 h and/or each delivery of incoming materials
Resistance to fixings	-	-	Manufacturer's method and/or verification of supplier's declaration	Once every 8 h and/or each delivery of incoming materials
Durability- Metal substructure components according to Table 9	-	-	Manufacturer's method and/or verification of supplier's declaration	Once every 8 h and/or each delivery of incoming materials
Durability- Other materials	-	-	Manufacturer's method and/or verification of supplier's declaration	Once every 8 h and/or each delivery of incoming materials
Dimensions, shape and tolerances	Not defined	-	Manufacturer's method and/or verification of supplier's declaration	Once every 2 h and/or each delivery of incoming materials

Table 13 — Minimum testing frequencies for suspended ceiling kits, using direct or indirect testing or assessment

Characteristics	Direct testing		Indirect testing or assessment	
	Test method	Frequency	Test method	Frequency
Fire resistance	-	-	Manufacturer's method and/or verification of supplier's declaration	Once every 8 h and/or each delivery of incoming materials
Shatter properties (impact resistance)	-	-	Manufacturer's method and/or verification of supplier's declaration	Once every 8 h and/or each delivery of incoming materials
Electrical safety	-	-	Manufacturer's method and/or verification of supplier's declaration	Once every 8 h and/or each delivery of incoming materials
Sound insulation	-	-	Manufacturer's method and/or verification of supplier's declaration	Once every 8 h and/or each delivery of incoming materials

6.3.3.3 Individual components or batches of components and the related manufacturing details shall be identifiable and retraceable.

6.3.4 Initial inspection of factory and of FPC

6.3.4.1 Initial inspection of factory and of FPC shall generally be carried out when the production is already running and the FPC is already in practice.

It is, however, possible that the initial inspection of factory and of FPC is carried out before the production is already running and/or before the FPC is already in practice.

6.3.4.2 The following shall be assessed:

- the FPC-documentation, and
- the factory.

In the assessment of the factory it shall be verified:

- a) that all resources necessary for the achievement of the component characteristics required by this European Standard are or will be (see 6.3.4.1) available, and
- b) that the FPC-procedures in accordance with the FPC-documentation are or will be (see 6.3.4.1) implemented and followed in practice, and
- c) that the component complies or will comply (see 6.3.4.1) with the initial type testing samples, for which compliance with this European Standard has been verified.

6.3.4.3 All factories of the manufacturer, where for the relevant component final assembling and/or final testing as part of the FPC is performed, shall be visited to verify that the conditions of 6.3.4.2 a) to c) are in place. One visit may cover one or more components, production lines and/or production processes. If the FPC system covers more than one component, production line or production process, and if it is verified that the general requirements (e.g. management structure, training policy) are fulfilled, these do not to be re-assessed

when assessing other components, production lines or production processes but the detailed verification of the component-specific FPC requirements for individual components shall still take place.

6.3.4.4 Assessments previously performed in accordance with the provisions of this standard may be taken into account providing that they were made to the same system of attestation of conformity on the same component or components of similar design, construction and functionality, such that the results may be considered applicable to the component in question.

6.3.4.5 Any assessment and its results shall be documented in a report.

6.3.5 Continuous surveillance of FPC

6.3.5.1 All factories which have been assessed according to 6.3.4 shall be re-assessed at a frequency sufficient to ensure that the FPC system continues to satisfy the requirements of this standard.

The frequency should be at least once a year.

6.3.5.2 Any assessment and its results shall be documented in a report.

6.3.6 Procedure for modifications

In the case of modification of the component, the method of production or the FPC system (where these may affect the declared performances), a re-assessment of the factory and of the FPC system shall be performed for those aspects which may be affected by the modification.

Any assessment and its results shall be documented in a report.

7 Marking, labelling and packaging

7.1 Marking and labelling

Each product shall be clearly and indelibly marked by the manufacturer either directly on the product, a label affixed to the product, a label on the package, on the accompanying commercial documents or by data stored on electronic media:

- the manufacturer's name, trade mark or identification mark,
- the number and year of publication of this European Standard, EN 13964:2014,
- symbols for the type and dimension,
- identification of the material(s),
- the year and month of manufacture.

NOTE Where the marking required by ZA.3 gives the same information as above, the requirements of this clause are met.

7.2 Packaging

Where used, the packaging shall allow the product to be transported and delivered without damage.

8 Technical documentation

The manufacturer's technical documentation shall specify how the constituent is part of the product and/or how the product or kit component is incorporated in the works.

Annex A (informative)

Guidance for installation

A.1 Introduction

NOTE The end use performance of suspended ceiling kits, or components in assembled systems, claimed by the manufacturer may only be achieved if they are installed in accordance with the manufacturer's installation instructions.

This annex gives guidance for the installation of a suspended ceiling in order to meet the performance requirements of this standard and additional guidance regarding the accuracy of installation.

A.2 Manufacturer's instructions

The installation of the ceiling system should be executed in accordance with the manufacturer's installation instructions. These instructions should include at least the following:

- specification of the required components for installation of the suspension system, substructure and membrane component,
- the way in which the various components have to be installed and fixed together,
- storage and handling of packs and individual components prior to installation,
- the required site conditions as specified in A.3.

Other required information is:

a) Suspension:

- 1) the maximum admissible load per suspension component,
- 2) the height adjustment and, if required, the means of securing the top and bottom fixings.

b) Substructure:

- 1) the admissible distance between suspension components in relation to the load per metre length of the suspended main runner,
- 2) the maximum admissible mass of lighting fixtures, etc. supported by the substructure, with and without extra suspension components,
- 3) the maximum cantilever length of the main runners,
- 4) the screw distances of edge trim,
- 5) the mutual connections of edge trim at inside and outside corners.

c) Membrane components:

- 1) the ways in which membrane components (as appropriate) have to be installed,

- 2) the way of making cut-outs for built-in lighting fixtures, etc.,
- 3) the maximum load to be carried by the membrane components,
- 4) the way of preparing (if necessary) other cut to size membrane components or linear ceiling components,
- 5) when and where hold down clips need to be applied, depending on the dead weight of the membrane component.

A.3 Site conditions

Installation may start when the building, or the relevant area of the building, is glazed, wind and/or water tight. Wet trades should be finished before installation. A relative humidity of not greater than 70 % and a temperature not lower than 7 °C should exist unless otherwise specified by the manufacturer.

Some materials are available, which do not require these conditions or limitations. The manufacturer should be consulted for advice on allowable conditions.

A.4 Supply and storage of materials

Ceiling materials should be kept dry during transport and storage. Any specific manufacturer's instructions should be followed.

A.5 Measurement and maximum deviations

A.5.1 Level mark

The height of the ceiling should be determined starting from a specified and indicated level mark.

A.5.2 Flatness

The maximum deviation from flatness should be less than or equal to 2,0 mm per metre length, with a maximum of 5,0 mm over a 5,0 m length, measured horizontally at the location of the suspension in any direction (linear interpolation is used to determine the tolerance on shorter lengths). These requirements apply for the installation of the substructure, the membrane components and the edge profiles.

The product tolerances as defined in Tables 3, 4 and 5 should be added separately to the flatness criteria.

A.5.3 Squareness

The substructure (main and cross runners) should be installed accurately square. The admissible deviation depends on the dimensions of the applied membrane components and their fixing system. A practical method to control the squareness of the grids is by means of a regular control of the diagonals during the installation and/or by means of a correct fit of the membrane components to be applied. Linear components and carriers should be installed absolutely square. The admissible deviation depends on the linear panel type but in practice, even slight deviations from square lead to visible deformations in the panels.

A.5.4 Alignment of linear components

Linear components, together with any elements and carriers, should be exactly aligned on module. Special care should be taken of the alignment of modules over the joint between carriers.

A.5.5 Cut to size membrane components

As a general requirement, membrane components are divided from the middle of the ceiling area, be it from the middle of the component or the middle of a joint between components, in such a way that adapter panels

have a minimum width of half the width (or length) of the standard panel. Otherwise, the division should be determined with the building designer, taking into account the location of columns, lighting fixtures, etc.

Cut to size membrane components, when pushed against the body of the T-profile, should be supported by the edge profile on the opposite side by at least 10 mm.

A.5.6 Fire resistant ceilings

Any insulation panels or slabs in the plenum should be installed against the surrounding walls, around columns and near suspension components, in ways that correspond to the tested ceiling for which the fire rating was obtained.

A.5.7 Top fixing and perimeter trim fixing

The selection of the appropriate top fixing and perimeter trim fixing should be carried out in accordance with Annex B.

In particular, attention should be paid to the following aspects:

- hole drilling to the correct diameter and depth,
- hole cleaning,
- installation procedure,
- use of correct setting equipment,
- tightening to specified installation torque where appropriate.

The type and number of top fixings or perimeter trim fixings shall be specified so that the loading capability of the fixing is not exceeded.

The type (e.g. concrete, light concrete, hollow bricks) and loading capability of the background shall be taken into account.

The chosen (selected) top fixing method shall be detailed on the relevant drawings.

Installation shall be carried out in accordance with the planning documents (i.e. design documents), if required with reference to the relevant part of ETAG 001 and ETAG 020 (e.g. test loading on site).

It is recommended to consult the manufacturer of the top fixing or perimeter trim fixing.

A.6 Mechanical resistance and stability of load bearing components

The design of the suspended ceiling shall be made so that the admissible building tolerances (limits of building tolerances) and the movement and deflection of the adjoining building assemblies (elements) are considered.

The stability of the suspended ceiling shall not be reduced (disturbed) as a result of the movement of adjoining building elements.

In the case of partitions fixed to the suspended ceiling, the forces imposed by the partition shall be carried either by suitable structural measures or transmitted by the suspended ceiling to the building structure.

Most suspended ceilings are not designed to support the additional load imposed by a partition. In case partitions are fixed to the suspended ceilings, only ceilings specifically designed for this purpose should be used.

Where the ceiling is intended to support additional loads, such as light fittings, air handling equipment or heating and cooling equipment, the ceiling shall be designed so as to be able to support these loads (e.g. by the inclusion of additional components).

Suspended ceilings shall be detailed so that through consideration of the conditions of use a failure or collapse of the membrane or substructure is not possible.

Annex B (informative)

Selection of top fixing and perimeter trim fixing

The following factors should be taken into account when selecting the appropriate top fixing and perimeter trim fixing:

a) Type of suspension component

As there are a wide variety of different fixings of all types of suspension components including wire, threaded rod and strap, care should be taken to ensure that the chosen fixing is suitable for the suspension components.

b) Base material of load bearing structure - Nature, strength and thickness

The chosen fixing should be suitable for and have adequate load capacity in the base material concerned, taking into account the compressive strength of the base material, including the possibility of that strength deteriorating with time (e.g. timber structures).

Where reference is not made to ETAs based on the relevant part of ETAG 001 or ETAG 020 (see 4.3.4), the suitability of fixings and design resistance shall be validated by:

- 1) reference to the fixing manufacturer's technical literature, or
- 2) by carrying out sufficient tests on representative samples of the base material,

both demonstrating equivalence with criteria set in the above mentioned ETAGs.

The thickness of the structure should be checked against the minimum requirements for the type and size of fixing chosen.

c) Design resistance

The overall design shall take into account the design method given by the designer. This may be found in an approval document (e.g. a European Technical Approval (ETA) in accordance with ETAG 001 or ETAG 020), or

- 1) by reference to the fixing manufacturer's technical literature, or
- 2) by carrying out sufficient tests on representative samples of the base material,

either demonstrating equivalence with criteria set in the above mentioned ETAGs.

Design resistance may vary with the type and strength of base material. Parameters limiting edge distances and spacing between anchors should always be checked and may involve reductions in design resistance.

d) Particular base materials

1) Concrete:

 Anchors in concrete should take into account 4.3.4.

Consideration should be given to the fact that the normal weight reinforced concrete, if used as a material for the load bearing structure, is supposed to be cracked within the limits allowed by the relevant design code (e.g. EN 1992) and therefore only an anchor approved to work in cracked concrete shall be considered. Anchors of redundant use, complying with ETAs based on ETAG 001-6, may be considered as approved for use in concrete that is cracked or non-cracked. Where the design of the ceiling fixing system is not based on redundancy, fixings complying with ETAs based on ETAG 001-2 to ETAG 001-5 may be considered, because these are approved for applications that may be redundant or non-redundant.

Fixings are available for all types of concrete ceiling structure including:

- i) Concrete – Normal weight – cracked and non-cracked,
- ii) Concrete – Hollow core slabs (EN 1168),
- iii) Lightweight aggregate concrete (EN 1520),
- iv) Aerated concrete (EN 12602).

Where reference is not made to ETAs based on the relevant part of ETAG 001 or ETAG 020, the suitability of fixings and design resistance should be validated by:

- v) reference to the fixing manufacturer's technical literature, or
 - vi) carrying out sufficient tests on representative samples of the base material,
- both demonstrating equivalence with criteria set in the above mentioned ETAGs.

2) Timber:

The fixing manufacturer should be consulted concerning the use of test fixings to determine the optimum configuration.

3) Metal decking and structural steel sections:

The fixing manufacturer should be consulted concerning the use of test fixings to determine the optimum configuration.

NOTE 1 Power actuated fixings or self-tapping screws may be appropriate for use in these materials.

NOTE 2 Where profiled metal decking is used as permanent formwork for lightweight aggregate concrete, it may be possible to specify an anchor specified in an ETA based on ETAG 001-6, depending on the particular qualifications in the approval document.

Annex C (informative)

Wind load resistance

In designing suspended ceilings, it is common practice that internal wind load is not taken into account. Only vertical downward dead load is taken into account in calculating mechanical resistance.

Many suspension systems are too flexible to counter any upward load which exceeds the dead-weight of the suspended ceiling, and many types of ceiling membrane are laid within the flanges of the substructure without any fixings.

In practice problems are usually avoided because:

- the internal wind load is normally restricted due to the fact that the prevailing wind load is limited,
- in severe weather conditions it is usual to close doors and windows,
- suspended ceiling systems have a certain permeability, which effectively reduces the actual upward or downward load to below the critical level which could cause uplift or collapse,
- in critical areas where occasional problems may occur, membrane components vulnerable to uplift are clipped down, for instance in entrance halls, near opening windows and doors and on top floors and corners of multi-storey buildings.

Annex D (normative)

Impact resistance

D.1 Scope

This annex describes the method for testing the resistance to ball impact of suspended ceilings for sports halls. It applies to suspended ceilings inside sports halls that can be subjected to impacts from a basketball, football, handball, medicine ball, tennis ball, volleyball, etc.

This annex is not applicable to projectiles used in putting the shot.

D.2 Definitions

The following definition applies for the use of this annex:

resistance to ball impact

suspended ceilings are regarded as resistant to ball impact if they and their supporting structures do not undergo any major permanent change when subjected to mechanical stressing by balls

D.3 Test apparatus

D.3.1 Balls

Balls with the following properties shall be used for the tests:

Handballs	Mass:	425 g to 475 g
	Diameter:	18,5 cm to 19,1 cm
	Internal pressure:	1,2 bar (gauge pressure)

D.3.2 Ball gun

The handball test shall be carried out with a ball gun that can fire the ball at a variable velocity and direction. The gun shall be capable of being adjusted for different impact angles (vertical to horizontal) and for different ball velocities. Suitable holders shall be provided for the balls at the mouth of the barrel in accordance with the direction of firing and ball size. The gun shall principally comprise the following parts, for example, assembled as shown in Figure D.1:

- striker of approx. 1,5 kg; diameter approximately 97 mm, length at least 40 cm;
- barrel for striker, length at least 100 cm;
- compressed air tank, volume approx. 7,0 l;
- quick-acting discharge valve;
- pressure gauge, with scale graduation at least 0,1 bar.

To prepare a shot, fill the air tank with compressed air with the air pressure p_0 in the tank adjusted for the desired firing velocity v_s . By opening the quick-acting discharge valve, the compressed air is forced into the bottom of the barrel and drives the piston forward at speed. After an acceleration distance of 60 cm, the striker hits the ball and accelerates it over a further 40 cm. A stop then arrests the striker at the mouth of the barrel.

Dimensions in millimetres

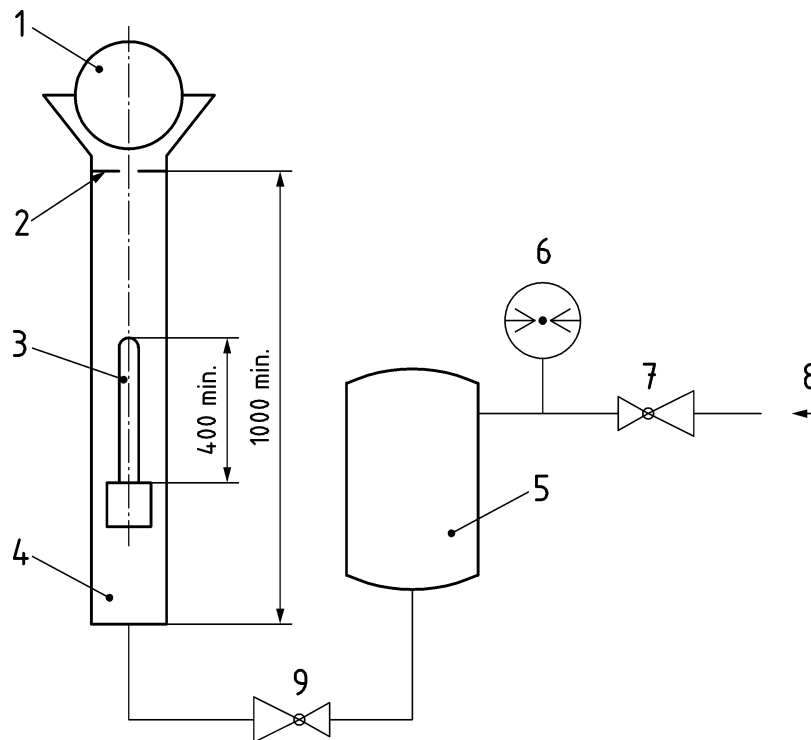

Key

- | | |
|-----------------------|--|
| 1 ball | 6 pressure gauge |
| 2 stop | 7 straight-way pressure reducing valve |
| 3 striker | 8 from compressor |
| 4 barrel | 9 quick-acting discharge valve |
| 5 compressed air tank | |

Figure D.1 — Ball gun (functional diagram)

D.4 Mounting of structural elements

For testing, mount the structural elements as in the sports halls. The test surfaces shall be designed to be large enough that they are representative both from a structural and functional point of view. The structure including the fastening devices to which the suspended ceiling to be tested is attached shall be solid enough that it does not move during the test.

D.5 Test procedure

D.5.1 General

Test the resistance to ball impact using the following specified method. Fire the shots so that the hits on the surface of the test element are distributed as uniformly as possible. If a weak spot appears during this test where damage adversely affecting the strength, function or safety is to be expected, fire two further shots at this spot.

In cases of doubt, repeat the test on the same test piece.

When using the ball gun, the distance between the front edge of each test surface and the mouth of the ball gun shall be between 1,5 m and 6 m.

D.5.2 Calibration of the ball gun apparatus

Before commencement of the impact resistance test, the ball gun apparatus shall be calibrated as follows:

Fire the handball with the ball gun apparatus into a "tunnel" with known length. The distance between the ball-mount and the opening of the "tunnel" shall be set to ensure maximum acceleration of the ball when entering the opening of the "tunnel". Upon entering the "tunnel" the handball shall pass through a light-beam, triggering a timing device. When hitting the back wall of the "tunnel" a pressure-sensitive plate, connected to the same timing device, is depressed stopping the timing operation. The velocity of the handball can be calculated by dividing the distance travelled by the handball (from ball-mount till the pressure plate on the back wall) with the elapsed time. If required the velocity of the handball can be adjusted through the pressure of the air in the tank and the setting of the quick-acting discharge valve (see Figure D.1).

D.5.3 Testing of ceiling elements

Attach the ceiling elements to the test ceiling. For products classified 1A to 3A (see Table D.1), fire a handball 36 times at the suspended ceiling with an impact velocity according to Table D.1, 12 times vertically and then 12 times each from two different directions at an angle of 60° (measured as the angle between the direction of impact and the surface plane of the suspended ceiling).

Table D.1 — Classes of impact velocity

Impact balls	Hand ball	Speed of impact
Classes	1A	(16,5 ± 0,8) m/s
	2A	(8,0 ± 0,5) m/s
	3A	(4,0 ± 0,5) m/s

When the ceiling is more than 2,0 m higher than the point from which the ball is fired, calculate the firing velocity v_0 in m/s required to obtain the specified impact velocity as follows:

$$\text{Req. } v_0 = (0,043 \cdot \Delta h + 0,914) \cdot 16,7 \quad (\text{D.1})$$

where

Δh is the difference in height between the firing point and the ceiling in metres.

The calculation applies to both vertical shots and those at an angle.

D.6 Evaluation

After the impact test, the strength, function and safety of the suspended ceiling shall not have been adversely affected and its appearance shall not have changed to any great degree. Visual examination is adequate to assess this.

Between shots, visual checks shall be carried out continuously to establish what changes the suspended ceiling has undergone. After the test, record the condition of the ceiling by dimensional details of permanent deformations and photographs of the changes.

D.7 Test report

The test report shall contain the following information:

— person requesting test,

- name of manufacturer,
- marking, product name and type designation (if appropriate),
- brief description of main characteristics of test piece and its attachments,
- test site,
- changes to suspended ceiling during test,
- test result, expressing the condition of the ceiling by dimensional details of permanent deformations and photographs of the changes,
- reference to any limiting conditions under which the test result is applicable,
- date of test.

Annex E (normative)

Formaldehyde classes and associated test methods

The test requirements for both initial type testing and factory production control shall be in accordance with Table E.1 for Class E1 products and Table E.2 for Class E2 products. The limit values for the formaldehyde release Class E1 are given in Table E.1 and for Class E2 in Table E.2.

NOTE Products of Class E1 can be used without causing an indoor air concentration greater than $0,1 \times 10^{-6}$ (0,1 ppm) HCHO in conditions according to EN 717-1.

EXAMPLE Examples for products in Class E1 are:

- cement bonded particleboards (unfaced);
- wet process fibreboard (unfaced), when no formaldehyde emitting resin has been added during the process; and
- unfaced, coated or overlaid wood based panels glued with resins emitting either no formaldehyde or negligible amounts of formaldehyde after production, such as isocyanate phenolic glue.

The values according to EN 120 for particleboard and MDF apply to boards conditioned to moisture content of 6,5 %. In the case of particleboard or MDF with different moisture contents, the test result to EN 120 (known as the perforator value) shall be multiplied by the *F* factor given in EN 312 (particleboard) or EN 622-1 (MDF). The factors *F* in these two standards are only valid for boards within the specified moisture content ranges given in the two standards.

Table E.1 — Formaldehyde release Class E1

		Panel product		
		Unfaced	Unfaced	Coated or overlaid
		Particleboard OSB MDF	Plywood Solid wood panels	Particleboard OSB MDF Plywood Solid wood panels Fibre boards (wet process) Cement bonded particleboard
Initial type testing ^a	Test method	EN 717-1		
	Requirement	Release $\leq 0,124 \text{ mg/m}^3$ air		
Factory production control	Test method	EN 120	EN 717-2	
	Requirement	Content $\leq 8 \text{ mg/100 g}$ oven dry board	Release $\leq 3,5 \text{ mg}/(\text{m}^2\text{h})$ or $\leq 5 \text{ mg}/(\text{m}^2\text{h})$ within 3 days of production	Release $\leq 3,5 \text{ mg}/(\text{m}^2\text{h})$
^a For established products, initial type testing may also be done based on existing data from EN 120 or EN 717-2 testing, either from factory production control or from external inspection.				

Table E.2 — Formaldehyde release class E2

		Panel product			
		Unfaced	Unfaced	Coated or overlaid	
		Particleboard OSB MDF	Plywood Solid wood panels	Particleboard OSB MDF Plywood Solid wood panels Fibre boards (wet process) Cement bonded particleboard	
Initial type testing	either	Test method	EN 717-1		
		Requirement	Release >0,124 mg/m ³ air		
	or	Test method	EN 120	EN 717-2	
		Requirement	Content >8 mg/100 g to ≤ 30 mg/100 g oven dry board	Release > 3,5 mg/(m ² h) to ≤ 12 mg/(m ² h) within 3 days of production	Release >3,5 mg/(m ² h) to ≤ 8 mg/(m ² h)
Factory production control		Test method	EN 120	EN 717-2	
		Requirement	Content > 8 mg/100 g to ≤ 30 mg/100 g oven dry board	Release > 3,5 mg/(m ² h) to ≤ 12 mg/(m ² h) within 3 days of production	Release > 3,5 mg/(m ² h) to ≤ 8 mg/(m ² h)

Annex F (normative)

Membrane components – Flexural tensile strength test

F.1 General

This annex describes a test method for determining the flexural tensile strength of membrane components for suspended ceilings. The test can be carried out with or without an additional static load applied on the specimen and under different environmental conditions.

The purpose of the test is to determine whether:

- a ceiling membrane component has sufficient strength to support its own weight when installed in a substructure,
- a ceiling membrane component has sufficient strength to support its own weight and a defined additional load when installed in a substructure.

For the first and second items, the load bearing capacity of the membrane component will be the decisive factor for the assessment (interpretation) of the test result.

NOTE Criteria related to health, such as development of mould and bacterial growth, are not covered by the flexural tensile strength test.

F.2 Test equipment

F.2.1 General

The equipment used to carry out the test shall consist essentially of the following:

- a frame in which the specimen is placed,
- equipment for measuring the deflection of the test specimen,
- equipment for loading the specimen,
- a chamber or room where the temperature, moisture content of the air and relative humidity can be controlled,
- a balance,
- a support plate used when measuring twist.

F.2.2 Test frame

F.2.2.1 Standard test frame

The frame shall be designed to reproduce the boundary and support conditions that are relevant for normal use of the ceiling membrane component.

The frame shall consist of steel profiles with sufficient strength and stiffness to support the specimen without deforming throughout the complete test procedure.

F.2.2.2 Specially designed test frame

If the standard test frame is not appropriate for the purpose of reproducing the boundary and support conditions that are relevant for normal use of the ceiling membrane component, a specially designed test frame shall be used, taking into account the following provisions.

This is for example suitable when the ceiling membrane component consists of a tile which is intended to be fixed by means of screws or nails to the underside of a timber or metal framework according to Figure 5 a) and c).

The same shall apply to metal linear components that, in normal use, are locally supported by supporting members, set at a distance which may be defined by the manufacturer.

The test frame shall be designed with sufficient strength and stiffness to support the specimen without deforming throughout the complete test procedure.

F.2.3 Loading equipment

F.2.3.1 Loading

Three types of loads may be applied:

- point load,
- linear load,
- evenly distributed load.

In the flexural tensile strength test (F.5.3) the load type shall be chosen by the sponsor of the test and reflect the end use condition of the ceiling membrane component.

In the test of the load-bearing capacity (F.5.4) the load type shall be evenly distributed.

F.2.3.2 Point load

Simulates a point-type load, e.g. a small light fitting normally mounted in, or attached to, the centre of the membrane component. The load shall be applied through a circular steel plate with a thickness of at least 3,0 mm and a diameter of 100 mm.

A mechanical jack and a load cell or a dead weight can be employed.

If a load cell is used, it shall have an accuracy of $\pm 5\%$.

F.2.3.3 Linear load

Simulates for example a linear light fitting or slot-type diffuser mounted in or along the centre line of the membrane component. The load shall be applied in the centre of the specimen and parallel with the support edges in case of a two sided supported specimen. When the specimen is supported on three sides or on all four sides, the load shall be applied in the centre of the specimen parallel with the long edges.

The load shall be applied through a horizontally applied steel cylinder (600 ± 25) mm long (or a dimension suitable for the test specimen format) and with a radius of 50 mm. The cylinder shall not rest on the supporting frame, neither directly or indirectly. A mechanical jack and a load cell or a dead weight can be employed.

If a load cell is used, it shall have an accuracy of $\pm 5\%$.

F.2.3.4 Evenly distributed load

Simulates for example an additional pad or inlay placed on top of the membrane component.

An inflatable buffer shall be used for distributing the load evenly to the specimen. On the top of the inflatable buffer, a load distributing plate shall be placed on which the load is applied.

A mechanical jack and a load cell or a dead weight could be employed.

If a load cell is used, it shall have an accuracy of $\pm 5\%$.

As an alternative to the inflatable buffer, dead weights consisting of for example sand bags with appropriate size may be used.

F.2.4 Test room/chamber

The test room/chamber which is hosting the test frame with the specimen shall be equipped with a system able to control the climate with respect to temperature, moisture content of the air and relative humidity.

It shall be possible to control the temperature between 20 °C to 40 °C with an accuracy of at least ± 2 °C.

It shall be possible to control the moisture content of the air between 3 g/kg of dry air and 20 g/kg of dry air with an accuracy of at least $\pm 5\%$.

F.2.5 Balance

A balance for weighing the specimen before and after a completed test shall be used.

The balance shall have an accuracy of at least ± 1 g.

F.3 Test conditions

F.3.1 Environmental conditions

One of the exposure levels in Table 8 shall be chosen by the sponsor of the test and established in the test room/chamber before commencement of the test. The chosen exposure level shall be clearly stated in the test report.

F.3.2 Restraints/boundary conditions

F.3.2.1 Mounting in standard test frame

The specimen shall be supported on its edges in a way representative of the use in practice. A membrane component with square edges (edge A) (see Figure 3) shall be supported along all of its four edges. A panel that in practice is only supported on two edges and has two free unsupported edges, for example edge D panels, shall be supported on only two edges. In the situation where adjacent panels are connected with splines along the unsupported edges, the test panel shall be tested with only two edges supported or with the appropriate splines on a larger test frame.

The width of the support and the distance between the supports of the specimen shall correspond to the support in practice.

F.3.2.2 Mounting in specially designed test frame

The specimen shall be installed in the test frame of the test frame with the same type of fixing elements and at the same centre distance as in practice. The span of the specimen (the distance between the supporting members) shall be chosen by the manufacturer and reflect normal application.

F.4 Test specimen

F.4.1 Size and characteristics

The test specimen shall consist of a membrane component of full size and with characteristics (e.g. density and thickness) representative of the membrane used in practice.

F.4.2 Number of specimens

Five tests per type and size of ceiling membrane component shall be carried out when determining the flexural tensile strength.

F.4.3 Conditioning

Preparation of test samples: Before initiating conditioning, test samples shall be stored, without packaging, in normal laboratory conditions for at least 12 h.

Products intended for uses covered by Table 8, Class A, no additional conditioning shall be performed. For products intended to be used in other classes, conditioning as foreseen in Table F.1 shall be performed prior to incorporating the test sample in the test assembly.

Table F.1 - Conditioning of test samples

Class	Temperature (°C)	Humidity (%RH)	Duration (h)
B	30 ± 2	90 ± 5	168 ± 1
C		95 ± 5	
D	Conditioning as specified by the manufacturer (in accordance with Table 8)		

F.5 Test procedure

F.5.1 Types of loading of the specimen

Two types of loading may be applied:

- without additional loading,
- with increasing load to declare additional load.

F.5.2 General

Weigh the test specimen, take and record the measurements (i.e. length, width, height/thickness, material thickness).

Mount the test specimen in the test frame, which consists out of the grid that the product is intended to use with or in a test frame representative for the end use conditions.

Where relevant, test samples shall be submitted to testing within 30 min after leaving the conditioning chamber.

F.5.3 Test without loading (minimum normative requirement)

F.5.3.1 General

At least 5 test samples shall be subjected to testing.

F.5.3.2 Loading

The specimen shall be loaded with 2,5 times the dead weight of the specimen; a uniformly distributed load, which shall be capable to follow the shape of the deflecting sample (e.g. inflatable buffer, aircushion or sandbags).

The load shall be maintained for a duration of (600 ± 10) s.

F.5.3.3 Criteria

Failure of the test corresponds with collapse of the specimen or parts thereof.

All test samples shall pass the test. If 1 fails, 5 additional samples shall be subjected to testing and all subsequent samples shall meet the requirement.

F.5.3.4 Declaration of performance

No load related declaration is required since all products shall meet this requirement. The exposure class according to Table 8 shall be declared.

Table F.2 - Performance criteria for membrane component

Exposure Class according to Table 8	Load type (one or more of the following options)
A	No load (-) Point load (N) Linear load (N/m ¹) Evenly distributed load (N/m ²)
B	
C	
D	

The manufacturer's declaration for the product shall be in accordance with Table F.2 (see example):

EXAMPLE Flexural tensile strength: Class A / - or
 Class C / no load.

F.5.4 Test with additional load

F.5.4.1 General

Where claimed by the manufacturer an additional load maybe declared.

At least 5 samples shall be subjected to testing.

F.5.4.2 Loading

One additional preliminary tile shall be used to identify the approximate failure load, if manufacturer does not define a target maximum load.

Starting point for the following 5 tiles is 80 % of the estimated failure load or 80 % of the target maximum load defined by the manufacturer. The load shall be increased in steps of 5 % from the failure load. Load increments shall be implemented uniformly in less than 60 s.

Each load step shall be maintained for a duration of (600 ± 10) s.

- test results according to F.5.4.4.

F.7 Extended field of application

The test results are directly applicable to similar untested ceiling membrane components in the following cases:

- ceiling membrane components with smaller size (length and/or width);
- ceiling membrane components supported on three or four sides when tested supported only on two sides;
- ceiling membrane components with a greater length than tested, if the length of the tested ceiling membrane component is twice the width.

EXAMPLE The result for a membrane component with the dimension (600 × 1 200) mm is also valid for 600 mm wide ceiling membrane components with lengths greater than 1 200 mm.

Annex G (normative)

Suspension component – Functional test

For the design purposes of the suspension component, it can be necessary to carry out a functional test. In principle the execution of the functional test shall be representative of the situation in which the suspension component is applied. If no information about the practical application is available, the functional test shall be carried out as follows:

The functional test shall be conducted with three individual samples (components) each with $n = 10^5$ load cycles. The load frequency shall be 2 Hz (load cycles per second).

Components that are loaded only by tensile force shall be tested under pulsating load with the admissible load ($admF$) as the upper load and $0,4 admF$ as the lower load (see Figure G.1).

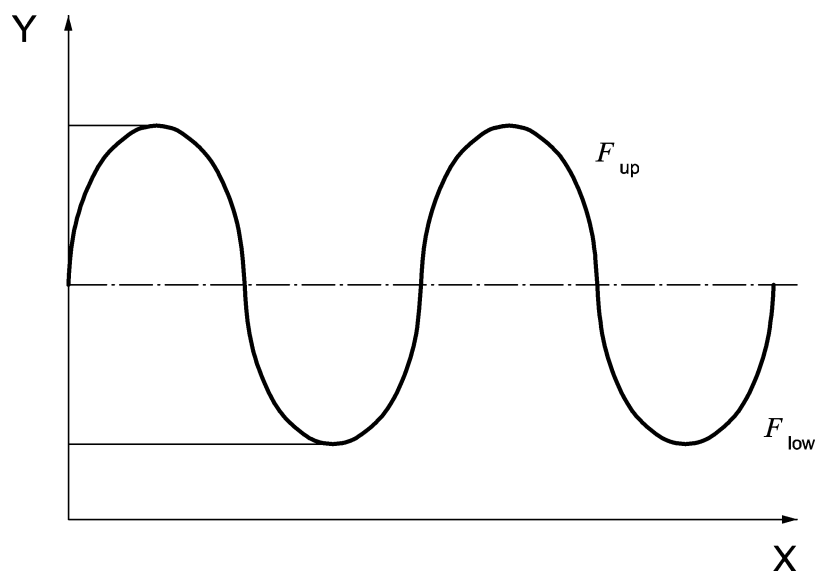

Key

T tension

upper load, $F_{up} = admF$

lower load, $F_{low} = 0,4 \cdot admF$

Figure G.1 — Tensile pulsating load

Components that are designed for both compressive and tensile load shall be tested under an appropriate alternating load, using compressive and tensile loads of 0,15 kN (see Figure G.2).

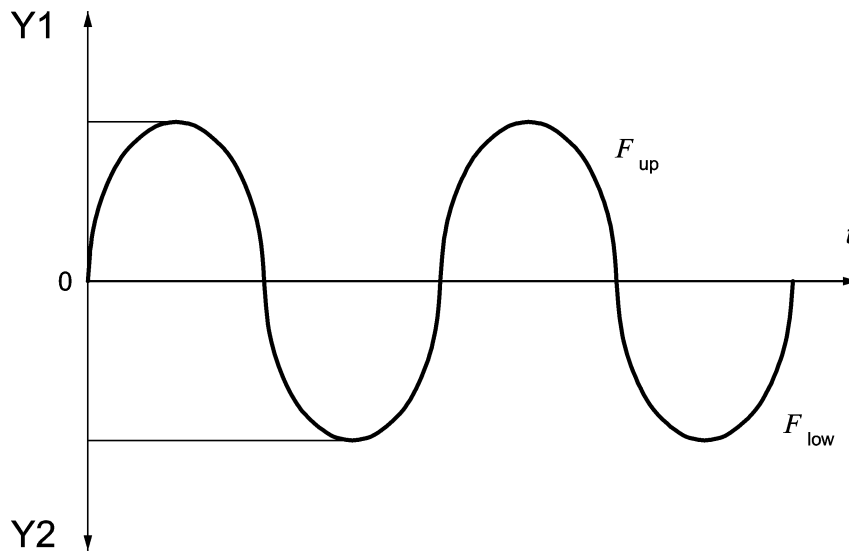

Key

T tension

C compression

T time (s)

upper load, $F_{up} = 0,15 \cdot admF$

lower load, $F_{low} = 0,15 \cdot admF$

Figure G.2 — Alternating load (tension-compression)

The displacement of the loading point shall be measured during all tests and stated to the nearest 0,1 mm. A progressively increasing deformation during the pulsating load test shall not be permissible.

No defects shall be present in any of the samples after finishing the functional test.

If the suspension component fails the functional test, the load in the static test (5.3.2) shall be reduced appropriately (see also Figure G.3) and the functional test repeated.

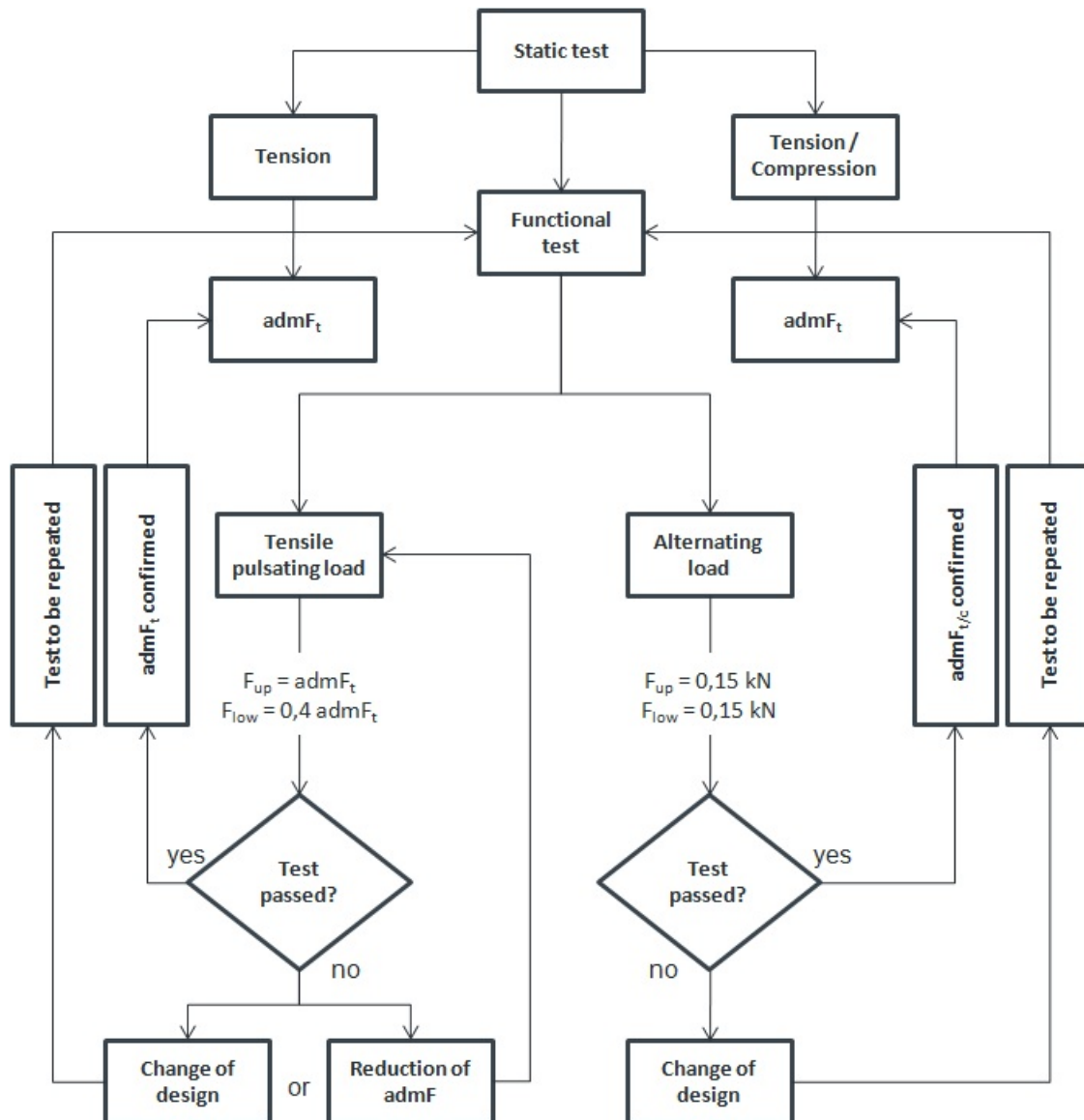

Figure G.3 — Test scheme for suspension elements and connectors - static test and functional test

Annex H (normative)

Perimeter trim component- Functional test, determination of load bearing capacity

H.1 General

In occasion, perimeter trims can have a load-bearing function. In case of load-bearing perimeter trims, the maximum allowed point load F_{eff} shall be determined and declared by the manufacturer.

NOTE 1 The responsibility of the manufacturer is limited to the determination and declaration of the load bearing capacity of the perimeter trim itself and cannot expand to the fixing method or to the load bearing construction to which the perimeter trim is fixed.

NOTE 2 It is the responsibility of the installer:

- to choose the fixing method appropriate for the specific type of wall or substructure;
- to determine whether the specific type of wall or substructure is sufficiently strong to carry the particular load.

H.2 Basic test for perimeter trims

H.2.1 Test installation

On a test rig, two parallel walls shall be simulated using 30 mm thick calcium silicate boards (see Figure H.1), for security and stability they may be fixed to an outside structure.

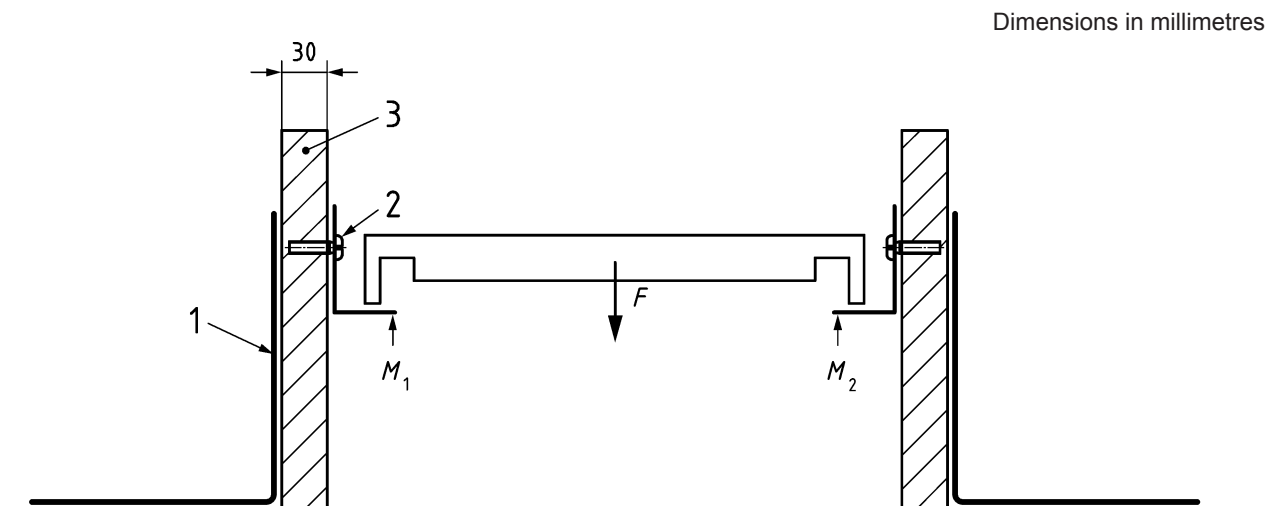

Key

- F load
1 supplementary structure allowed to fix the calcium silicate (C)
2 fixing of perimeter trim
3 calcium silicate boards
 M_1 and M_2 measuring points for deflection

Figure H.1 — Schematic presentation of the test rig

NOTE The test rig may be constructed in such a way that at least one of these walls can be shifted into another parallel position to allow the use of the same testing equipment for perimeter trims of different dimensions.

There shall be no fixed distance between these walls, allowing flexibility for any kind of perimeter trim structure. The width of the wall shall be at least 350 mm; the height shall depend on the way the load is applied.

H.2.2 Fixing the perimeter trims

The perimeter trim shall be attached to both walls with (3,5 × 20) mm steel slotted round head wood screws (see Figure H.2) at centre distance 250 mm or as prescribed by the sponsor of the test. If the centre distance is different from 250 mm, the actual distance shall be specified in the test report and in the declaration of conformity. The perimeter trim shall exceed each fixing point by (50 ± 5) mm. The perimeter trims shall be predrilled or perforated avoiding deformation. The hole diameter shall be (3,8 ± 0,2) mm. At the fixing points, the calcium silicate walls shall be predrilled with holes of (2,5 ± 0,2) mm avoiding deformation of the calcium silicate.

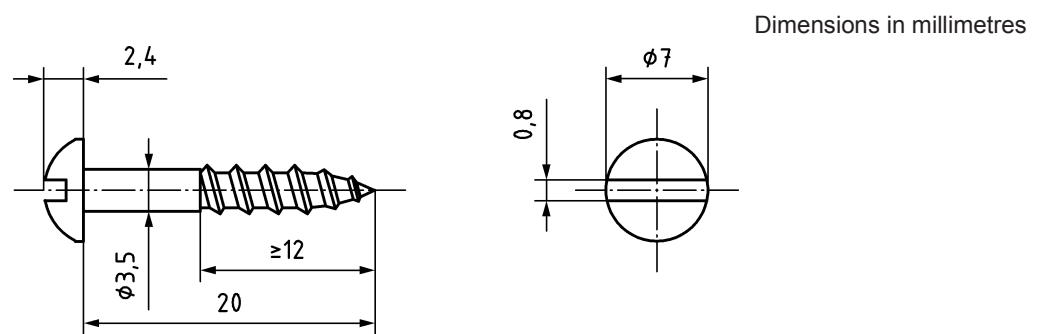

Figure H.2 — Fixing screw

If a perimeter trim is thicker than 3 mm at the fixing point, the use of longer screws of the same type shall be allowed, as long as their round head and diameter are equal to the standard screw described above.

The position of the screw shall be at 1/3 of the height of the perimeter trim (see Figure H.3), measured from the top of the trim. For determining the fixing height, only the perimeter trim part directly abutting the wall shall be taken into account.

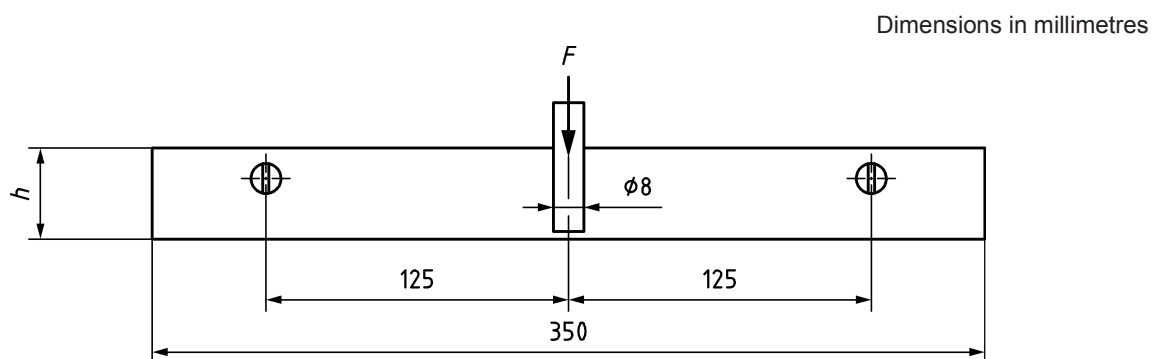

Figure H.3 — Position of the screws

H.2.3 Test load

The load on the perimeter trim shall be transferred by an (8 ± 1) mm round rod that has been cut off flat at the bottom where it touches the perimeter trim. The load shall be applied in the direction of the arrow F on Figure H.3. The load shall be applied using an appropriate structure that accurately divides the load over both perimeter trims. The way of applying the load (pull from bottom or push from above) shall depend only on the installation used to provide the load.

H.2.4 Number of tests

Three tests per type and size of perimeter trim shall be carried out when determining the load bearing capacity.

H.2.5 Application of the load

An increasing point load shall be applied halfway the width of the bottom horizontal flanges of the two opposite perimeter trims in equal steps of 1 N or 10 N. The load shall also be positioned halfway between the fixing points (see Figures H.3 and H.4).

Dimensions in millimetres

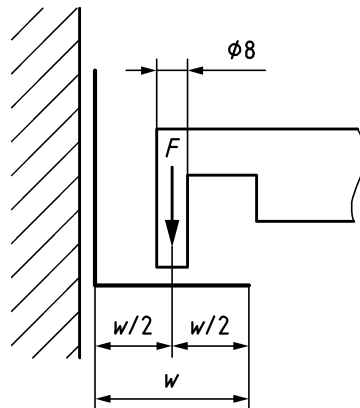

Figure H.4 — Load application

The load shall be increased until the total deflection of the outer edges of both perimeter trims (Figure H.1, M_1 and M_2) reaches an average of 0,8 mm (i.e. the sum of the deflection at M_1 and the deflection at M_2 shall be 1,6 mm).

The load F shall be recalculated to the minimum material thickness of the perimeter trim in question with a security factor of 10 % as follows:

$$F_{eff} = \frac{F \times T_{min}^2 \times 0,9}{T_{meas}^2} \quad (H.1)$$

where

- F is load, in N or kN, on one perimeter trim at the moment the average 0,8 mm deflection is reached;
- T_{min} is minimum thickness of the perimeter trim, in mm;
- T_{meas} is measured average thickness of both perimeter trims, in mm;
- F_{eff} is load value, in N or kN, that is to be published.

The load F on one perimeter trim is to be half of the lowest load applied on a set of 2 perimeter trims during the 3 tests. If loading is done according to H.2.7 per single perimeter trim then the load F on one perimeter trim is the average between the two lowest load results of the 6 tests.

H.2.6 Perimeter trim thickness

To establish the measured average thickness of both perimeter trims, each of the two tested perimeter trims shall be measured at 8 different places, divided over all flanges with the same presumed thickness. Measuring shall be accurate at $\pm 0,001$ mm (thickness including standard finishes like paint). The mean average of the 16 measures shall be taken as the measured thickness T_{meas} .

The minimum thickness T_{min} shall be the minimal allowed total material thickness taking into account all the material and finishes tolerances.

H.2.7 Alternative testing

The above described test method shall be the preferred one.

When only the possibility of performing the test just on one perimeter trim at a time exists, the following alternative test method may be followed. When this alternative test method is used, the following conditions shall apply:

- the total number of samples subjected to testing remains the same (test 6 times 1 piece instead of 3 times 2 pieces);
- all parameters – fixing into the frame, distance between fixing points, type of screws, etc. – shall be identical to the above described test method;
- the test report shall mention that the perimeter trims were tested as single pieces and not as sets of two, by mentioning: "The test was performed on single perimeter trims as described in EN 13964, referring to this paragraph".

When the sponsor of the test recommends a distance between fixing points larger than 250 mm in his installation guidelines, this alternative testing may be done as requested by the sponsor and the actual distance shall be specified in the test report and the declaration of conformity.

H.2.8 Test report

The test report shall contain at least the following information:

- manufacturer and manufacturing plant;
- identification of the product (description and physical characteristics);
- information about the sampling:
 - date and time of sampling;
 - production line or unit;
 - personnel involved in sampling;
 - applied sampling method, if any;
- identification of the organization and personnel executing the test;
- applied test method:
 - test conditions and configuration;
 - number of test performed;

- place and date of testing;
- place and date of delivery of the test report;
- registration number of the testing laboratory (where relevant);
- signature of the head of the testing laboratory and stamp;
- test results.

Annex I (normative)

Reaction to fire test - Mounting and fixing

I.1 Dimensions of the test rig in accordance with EN 13823

The test rig, in accordance with EN 13823, consists of a corner with a long and a short wing. The long wing consists of 2 modules, with at least one vertical and one horizontal membrane to membrane joint in the long wing. All membranes shall be tested vertically. The dimensions of the test specimens shall be in accordance with Table I.1.

Table I.1 — Dimensions of the test specimens

	Nominal assembly dimensions (mm)	
	Length	Height
Short wing	500	1 500
Long wing	200 + t ^a	
	800 - t ^a	
^a Thickness of the assembly in millimetres.		

I.2 Ceiling membrane components

I.2.1 Mounting and fixing in accordance with EN 13823

I.2.1.1 Ceiling membrane components that are to be tested with insulation or other material

I.2.1.1.1 General

These specifications apply for ceiling membrane components in accordance with 4.4.2.2, b).

I.2.1.1.2 Test specimen

The ceiling membrane component shall be mounted and fixed according to EN 13823.

The test specimen shall fully represent the end use conditions of the suspended ceiling utilizing all the envisaged components in the end use condition as specified by the applicant, as far as possible. The external surface of the membrane used in the test assembly shall include a representative substructure (grid) as a means of fixing the membranes.

Where the ceiling membrane component may be used together with thermal or sound insulation backing materials, the ceiling membrane component shall be tested together with these additional materials under end use conditions, as far as possible.

Suspended ceilings, where the ceiling membranes are "suspended" through the use of the substructure components (e.g. "lay-in", "clip-in" or "hook-on") and not mechanically fixed, making it impossible to assemble the substructure and membrane in an SBI assembly, representing real end use application, shall be fixed with at least 4 metal screws (simulating behaviour in end use conditions as far as possible), unless the assemblies are self-supporting, i.e. not requiring any fixing. These screws shall be fixed at least 25 mm from the edges of the suspended ceiling membrane.

If an air gap is to be foreseen, spacers (distance holders), with a thickness of (40 ± 1) mm, made out of calcium silicate (material as referred to in EN 13238 as one of the possible substrates) shall be used, unless the air gap can be obtained without using spacers (e.g. in case the assembly is self-supporting). If screws are used to fasten the substructure and/or the ceiling membrane, they shall penetrate the spacers at least 25 mm from the edge of the calcium silicate spacers.

If the membrane is intended to be used in practice without any joints, the test assembly shall also be made without joints. If joints are used in practice, there shall be at least one joint 200 mm from the corner and 500 mm from the bottom of the assembly (see Figures I.1 a, I.1 b, I.2 a and I.2 b). In this case, additional joints may be necessary, depending on the dimensions of the membrane. Joints between membranes in the test assembly shall be based on the dimensions of the product as placed on the market.

NOTE 1 The substructure is only representative of the end use fixing. The product being assessed is the ceiling membrane itself, and not a kit. However, in end use, the membrane is held in position by a grid. The grid used therefore needs to have the minimum profile with which the ceiling membrane component can be used.

NOTE 2 A suitable solution is to fix 4 adjacent suspended ceiling membrane corners in one calcium silicate board.

NOTE 3 Suspended ceilings are intended to be used horizontally and any air gap between the substrate and the ceiling membrane or insulation does not lead to a "chimney effect". Therefore, the air gap is fixed, by convention, at 40 mm, as specified in EN 13823.

NOTE 4 In the case of a metallic grid which is not exposed, seen from the membrane front side, the grid could be excluded from being a part of the test specimen as given in Figures I.1 a, I.1 b, I.2 a and I.2 b.

The corner detail between long and short wing shall be sealed with a material having a reaction to fire class A1 in accordance with EN 13501-1, preventing exposure of the internal surface of the suspended ceiling membrane, or other material, to the fire.

The type and dimensions of materials and products used, the dimensions and location of fixings, etc. shall be recorded in the test report.

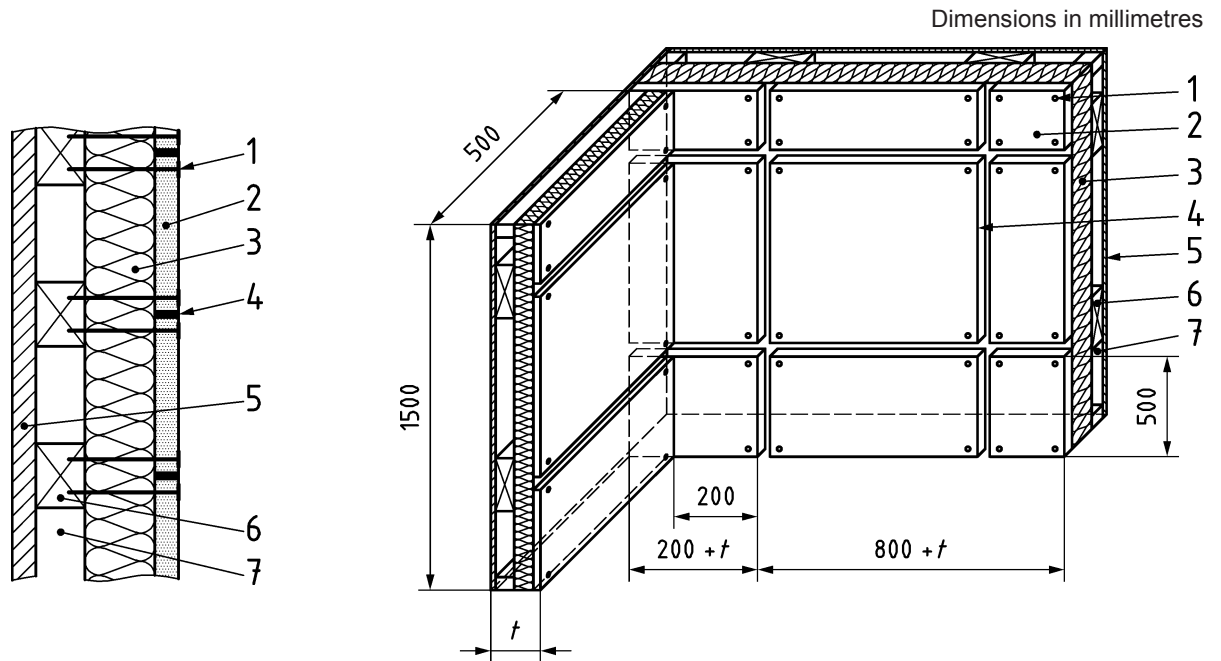

Key

- 1 fixing
- 2 suspended ceiling membrane
- 3 insulation
- 4 suspended ceiling substructure
- 5 substrate
- 6 spacer
- 7 air gap
- t thickness of the test specimen (including substrate)

Figures I.1a and I.1b — Mounting and fixing for SBI in case of suspended ceilings kit test, with insulation and air gap

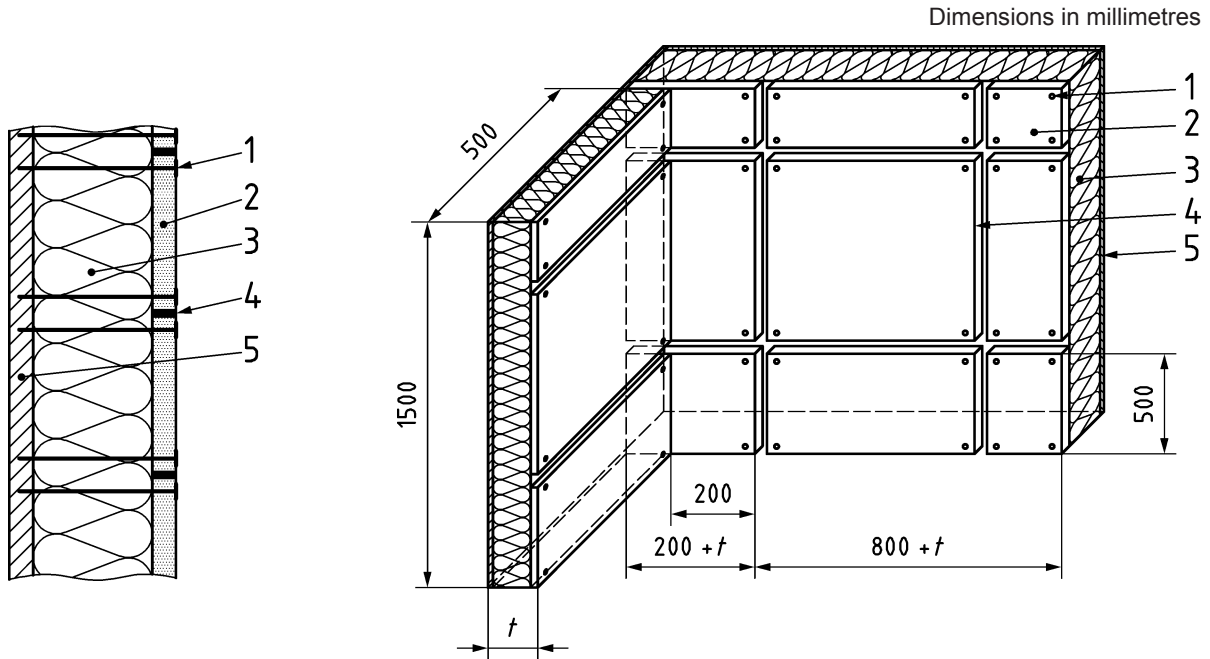

Key

- 1 fixing
- 2 suspended ceiling membrane
- 3 insulation
- 4 suspended ceiling substructure
- 5 substrate
- t thickness of the test specimen (incl. substrate)

Figures I.2a and I.2b — Mounting and fixing for SBI in case of suspended ceiling kit test, with insulation and without air gap

I.2.1.2 Ceiling membrane components that are tested and classified on their own

I.2.1.2.1 General

These specifications apply for ceiling membrane components in accordance with 4.4.2.2, a).

I.2.1.2.2 Test specimen

The ceiling membrane component shall be mounted and fixed according to EN 13823.

The test specimen shall be composed of the ceiling membrane component fixed as specified by the applicant, where this is possible without using the substructure. Otherwise, the external surface of the membrane used in the test assembly shall be fixed with at least 4 metal screws (simulating behaviour in end use conditions as far as possible). These screws shall be fixed at least 25 mm from the edges of the suspended ceiling membrane.

If an air gap is to be foreseen, spacers (distance holders), with a thickness of (40 ± 1) mm, made out of calcium silicate (material as referred to in EN 13238 as one of the possible substrates) shall be used. The screws shall penetrate the spacers at least 25 mm from the edge of the calcium silicate spacers.

If the membrane is intended to be used in practice without any joints, the test assembly shall also be made without joints. If joints are used in practice, there will be at least one joint 200 mm from the corner and 500 mm from the bottom of the assembly (see Figures I.3 a, I.3 b, I.4 a and I.4 b). In this case, additional joints may be necessary, depending on the dimensions of the membrane. Joints between membranes in the test assembly shall be based on the dimensions of the product as placed on the market.

NOTE 1 A suitable solution is to fix four adjacent suspended ceiling membrane corners in one calcium-silicate board.

NOTE 2 Suspended ceilings are intended to be used horizontally and any air gap between the substrate and the ceiling membrane does not lead to a “chimney effect”. Therefore, the air gap is fixed, by convention, at 40 mm, as specified in EN 13823.

NOTE 3 In the case of a metallic grid which is not exposed, seen from the membrane front side, the grid can be excluded from being a part of the test specimen as given in Figures I.3 a, I.3 b, I.4 a and I.4 b.

The corner detail between long and short wing shall be sealed with a material having a reaction to fire class A1 in accordance with EN 13501-1, preventing exposure of the internal surface of the suspended ceiling membrane, or other material, to the fire.

The type and dimensions of materials and products used, the dimensions and location of fixings, etc. shall be recorded in the test report.

I.2.1.3 Product families

In case suspended ceiling membranes are intended to be placed on the market with different edge details (e.g. squared, bevelled, rebated, grooved), the membranes may be grouped by material volume, in which case the suspended ceiling membrane with the highest edge detail volume (most extreme being the squared edge) shall be subjected to SBI-testing.

Different faced or coated suspended ceiling membranes, intended to be placed as such on the market, shall be classified. Faces or coatings may be grouped by PCS-value, in which case the suspended ceiling membrane with the highest PCS-value face or coating shall be subjected to SBI-testing. If the PCS-value does not lead to differentiation, the suspended ceiling membrane with the darkest coloured face or coating shall be subjected to SBI-testing. Alternatively, the influences of different colours of facings or coatings can be determined by performing SBI-tests on a light, on a dark and on a colour in the middle of the range.

NOTE Directional patterns and surface textures, covered by the scope of this standard (see Clause 1), do not influence fire behaviour in end use conditions. If suspended ceiling membranes have directional patterns and surface textures, they are to be mounted in a pattern, preventing influences on test results, due to the test method, as far as possible.

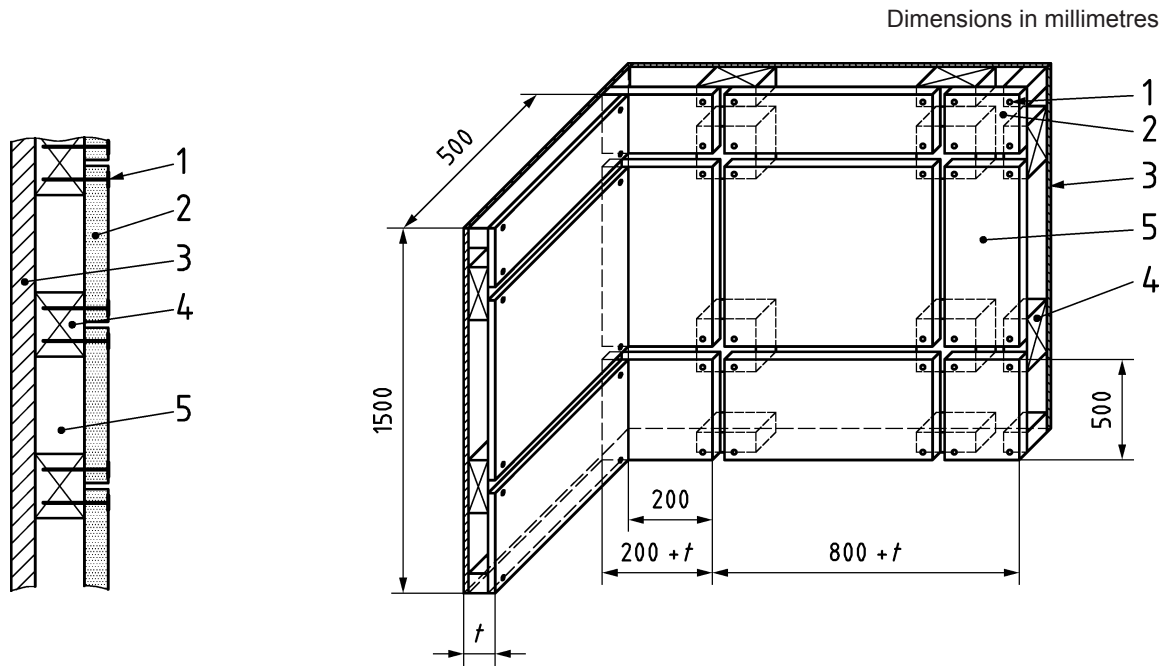

Key

- 1 fixing
- 2 suspended ceiling membrane
- 3 substrate
- 4 spacer
- 5 air gap
- t thickness of the test specimen (incl. substrate)

Figures I.3a and I.3b — Mounting and fixing for SBI in case of suspended ceiling membrane test, with air gap

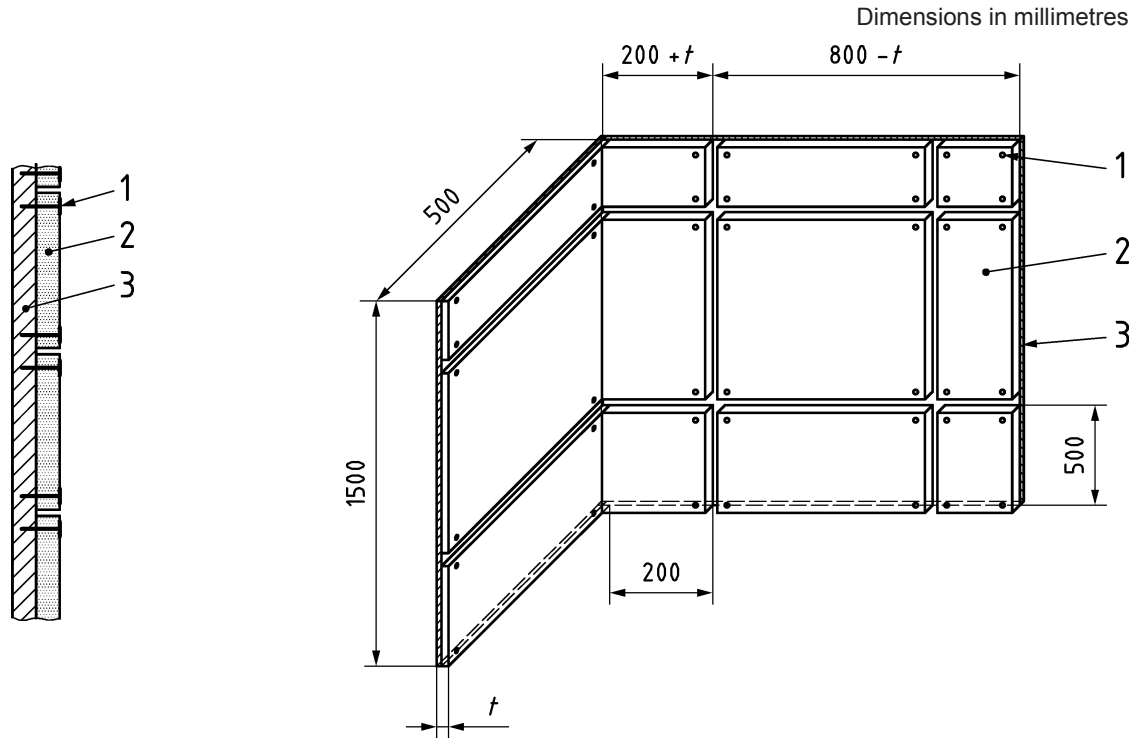

Key

- 1 fixing
- 2. suspended ceiling membrane
- 3 substrate
- t thickness of the test specimen (incl. substrate)

Figures I.4a and I.4b — Mounting and fixing for SBI in case of suspended ceiling membrane test, without air gap

I.2.1.4 Mounting and fixing of the test assembly

When testing to EN 13823, the test assembly shall be representative of end use conditions.

In accordance with manufacturer's specifications, suspended ceiling membrane components shall be tested incorporating an air gap which is to be ventilated and/or directly against the substrate. The results of testing without air gap cannot be used to classify applications with air gap, and vice versa.

The choice of the substrate is for the manufacturer to decide. This choice has a direct bearing on the intended end use application of the product.

In case of testing with air gap, the frame between the backing board and the specimen shall be open at the sides to allow ventilation into the gap.

The assembly may be prepared and fixed together away from the test chamber. The complete assembly can then be transported to the chamber.

NOTE In the case of layered/coated ceiling membrane components, which are perforated, the area (m^2), to be considered for interpreting EN 13501-1 as regards non-substantial components, is the whole area (the overall area), including the area of the perforations.

I.2.2 End use application rules

I.2.2.1 General

The manner in which the product is tested has a direct consequence upon the manner in which the product or product family may be classified and used in the works. When determining the testing program for all aspects of membrane components, the following provides guidance on the potential end-use application rules which may apply dependent on the testing program undertaken.

I.2.2.2 Influence of substrate

The substrate used behind the ceiling membrane in the EN 13823 determines the type of ceiling below which the ceiling membrane can be used.

If the ceiling membrane component was tested in front of particleboard, the membrane can be used below any wood structure, plasterboard or any other product having a reaction to fire class A1 or A2 in accordance with EN 13501-1 in end use.

If the membrane was tested in front of plasterboard the membrane can be used below plasterboard or any other product having a reaction to fire class A1 or A2 in accordance with EN 13501-1. It may also be used beneath a wooden ceiling provided the distance between the membrane and the ceiling is greater than 250 mm.

In the case of testing for class A1 according to EN 13823 the standard substrate shall be the 11 mm silicate board. There are no end use requirements in this case as class A1 in accordance with EN 13501-1 is considered for material properties only.

I.2.2.3 Influence of colour

Tests should only be conducted on the darkest colours. That classification applies to all colours.

I.2.2.4 Influence of coating thicknesses

If the coating to the front and reverse faces varies significantly in mass per unit area (> 1 %) and tests conducted on the minimum and maximum quantities yield the same classification, that classification applies to all coating thicknesses provided the value of each fire test parameter achieved is at least 10 % less than the criteria for that classification.

If different classifications are obtained, additional testing should be conducted to redefine the product family to which a single classification applies.

I.2.2.5 Influence of other variables

Other variable parameters such as organic content, type of coating, ceiling membrane component thickness, facings, etc. may be addressed in a similar manner to I.2.2.4.

I.3 Substructure components

I.3.1 General

Generally, substructure components are fabricated from either bare or painted metal. The bare metal is deemed to satisfy class A1. However, the reaction to fire class of painted metal shall be tested and classified in accordance with EN 13501-1.

NOTE Many paint systems (both powder coatings and wet applied) often have a PCS value greater than 2,0 MJ/kg (although they comply with the 2,0 MJ/m² requirement in Note 2 of the classification tables in EN 13501-1) and therefore the route to class A1 lies through tests to EN 13823. Therefore, mounting and fixing details needed to be determined.

I.3.2 Mounting and fixing in accordance with EN 13823

I.3.2.1 Dimensions of the test rig

The test to EN 13823 is essentially a test of the performance of the paint finish on the metal of the grid. The method that shall be used is to test the paint applied to metal panels, the metal being of the same gauge and having the same treatment for corrosion as the grid itself. Testing of the paint finish to the grid shall, therefore, be conducted on metal panels.

Alternatively, mounting and fixing by placing the grid side by side to form the specimen may be applied.

I.3.2.2 Test specimen

The metal panels shall be mounted and fixed according to EN 13823.

Each coating applied to the substructure, as intended to be placed on the market shall be subjected to testing. The coatings shall be applied to the metal of the same gauge as the grid, in the same thickness.

Influences of different colours of coatings may be determined by performing tests on a light, on a dark and on a colour in the middle of the range. Test results obtained from performing the test on the darkest colours apply to lighter colours as well.

Where different gauges of metal are used, the influence of this may be determined by performing tests on the thinnest and thickest gauge. Test results obtained from performing the test on the thinnest gauge apply to thicker gauges as well.

Where different thicknesses of paint are used, the influence of this may be determined by performing tests on the thinnest and thickest. Test results obtained from performing the test on the thickest paint apply to smaller thicknesses as well.

I.3.2.3 Mounting and fixing of the test assembly (see Figures I.5.a and I.5.b)

When testing to EN 13823, the test assembly shall be representative of end use conditions. Suspended ceilings incorporate by their very nature air gaps and therefore the coated metal shall be tested incorporating an air gap which shall be ventilated. In end use conditions, above the air gap, a number of different substrates can be found the most common of which are plasterboard, concrete and wood (of several different types).

Therefore, the mounting and fixing of the coated metal panels shall take these rules into consideration and the test specimen shall contain an air gap between itself and the chosen substrate which is placed against the backing board. The minimum distance between the substrate and the ceiling membrane shall be 40 mm. The choice of the substrate and the air gap distance is for the manufacturer to decide, however this has a direct bearing on the intended end use application of the product.

The frame between the backing board and the specimen shall be open at the sides to allow ventilation into the gap.

The assembly may be prepared and fixed together away from the test chamber. The complete assembly can then be transported to the chamber.

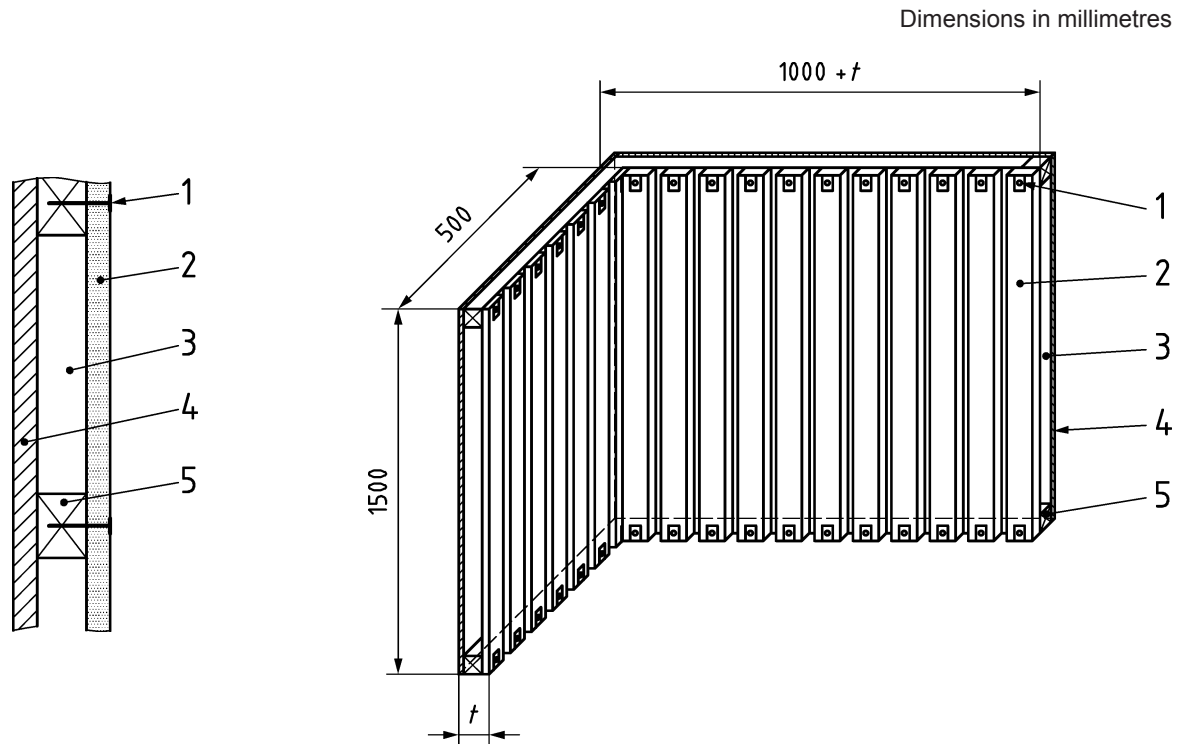

Key

- 1 fixing
- 2 suspended ceiling substructure
- 3. air gap
- 4. substrate
- 5. spacer
- t thickness of the test specimen (including substrate)

Figures I.5a and I.5b — Mounting and fixing for SBI in case of suspended ceiling substructure test, with air gap

I.3.3 End use application rules

I.3.3.1 General

The manner in which the product is tested has a direct consequence upon the manner in which the product or product family may be classified and used within the works. When determining the testing program all aspects of the substructure component in terms of its own parameters and its end use parameters need to be considered. For this construction product, the following provides guidance on the potential end use application rules which may apply dependant on the testing program undertaken.

I.3.3.2 Influence of air gap

The distance (X mm) between the coated metal and the substrate used in the EN 13823 test provides the minimum distance from the end use substrate at which the main runner and cross tees may be placed in end use.

I.3.3.3 Influence of substrate

The substrate used behind the substructure component in EN 13823 determines the type of ceiling below which the ceiling membrane can be used.

If the substructure component was tested in front of particleboard the membrane can be used below any wood structure, plasterboard or any other product having a reaction to fire class A1 or A2 in accordance with EN 13501-1.

If the substructure component was tested in front of plasterboard the membrane can be used below plasterboard or any other product having a reaction to fire class A1 or A2 in accordance with EN 13501-1. It may also be used beneath a wooden ceiling provided the distance between the membrane and the ceiling is greater than 250 mm.

In the case of testing for class A1 according to EN 13823, footnote, the standard substrate shall be the 11 mm silicate board. There are no end use requirements in this case as class A1 in accordance with EN 13501-1 is considered for material properties only.

I.4 Reaction to fire requirements for small products and components

I.4.1 Principles

The reaction to fire performance of products and kit components, which have an insignificant influence on the development of a fire, i.e. their contribution to fire spread is insignificant and influences on the fire behaviour of the neighbouring products when assembled is not to be expected, need not be tested.

The same applies to constituents of products if their contribution to fire spread is insignificant and influences on the fire behaviour of the neighbouring constituents is not to be expected.

When assessing products or kit components and their contribution to fire growth, distinction needs to be made between products or kit components used in, on or to fasten structural elements which fulfil, in addition, fire resistance requirements and products or kit components used in, on or to fasten structural elements that do not. For elements where the fire resistance performance may be influenced by small products or kit components, the reaction to fire performance of the products or kit components shall not be neglected. In this case, only small combustible surfaces or constituents of kit components or products may be considered as negligible, when a contribution to fire propagation clearly is not expected.

I.4.2 Small kit components

A product or kit component, not having a reaction fire class A1 or A2 in accordance with EN 13501-1, does not need to be tested and classified separately when it has, in intended end use application, such a small size or small surface area that a contribution to fire growth or (in a fully developed fire) a contribution to smoke development and/or the production of flaming particles/droplets from this material are not expected. It can be assumed that a kit component with a mass (≤ 50 g) and a surface area of (≤ 50 mm) \times (≤ 50 mm) is a small kit component, which does not need to be tested and classified separately.

EXAMPLE Fixings such as screws, (plastic) anchors, staples, clips, nails, bolts and nuts and rivets having constituents which are not class A1 in accordance with EN 13501-1 (e.g. surface coatings, plastic washers); plastic caps of screws or anchors.

NOTE Fixings would in any case need to have a head or washer, preventing the membrane to fall when subjected to fire.

Products or kit components, not considered as small products or kit components, shall be tested and classified according to EN 13501-1.

I.4.3 Small constituents

For small product constituents, not having a reaction fire class A1 or A2 in accordance with EN 13501-1, that form part of a composite product and are situated on the surface of a product made of material with reaction to fire classes B, C, D or E in accordance with EN 13501-1 (e.g. plastic caps of anchors or fillings of small hollow spaces), reaction to fire testing and classification is not necessary when similar products are at a distance of

more than 200 mm. However, the reaction to fire class of the product can be influenced by the small constituent and therefore shall be tested and classified as a whole.

I.4.4 Linear joint kit components

Linear joints, e.g. in or through walls or floors or between building elements or joints extending over the whole façade of a building might have small sizes on the surface of the elements, but can contribute to fire propagation. Therefore joints cannot be considered as products with small area/surfaces.

Fire spread due to the linear joint material on the surface of the element or the façade or to the interior shall be taken into account.

I.4.5 Embedded constituents

Small constituents embedded all-round in material of class A1 shall be considered, in the context of intended end use application, to satisfy any reaction to fire requirement.

EXAMPLE 1 When considering metal anchors with their different parts and components and the influence to the fire behaviour of the surrounding product, the metal parts of metal anchors (torque-controlled expansion anchors, undercut anchors, deformation-controlled expansion anchors) are assumed to satisfy the requirements for reaction to fire class A1, without the need for testing (CWT). The non-load bearing plastic parts of anchors or any coating (e.g. coating of the cone) are located near the inner end of the anchor and these parts are completely embedded in the concrete in their intended end use application. Furthermore, the plastic parts and the coating are very thin. Therefore, it may be assumed that these parts in connection with the metal anchor in end use application do not make any contribution to fire growth or to the fully developed fire and they have no influence to the smoke hazard. In the context of the intended end use application of the anchors, the plastic parts and the coating may be considered to satisfy any reaction to fire requirements.

The intended end use application of products shall be assessed, when a small constituent embedded in or on the surface of a construction product, not having a reaction to fire class A1, to determine whether the reaction to fire class of the surrounding product is influenced. Separate testing and classification of the small component is not required when an influence is not expected.

EXAMPLE 2 When considering plastic anchors for use in concrete and masonry, and the influence to the fire behaviour of the surrounding products, the metal parts of the anchors are assumed to satisfy the requirements for reaction to fire class A1, without the need for testing (CWT). The anchors are used to fix a suspended ceiling membrane (or other kit component) which is not class A1 and the plastic constituents of the anchor are located in the drilled hole of the substrate (concrete or masonry) and fixture. Where the plastic constituents of the anchor are embedded in concrete or masonry it may be assumed that they do not contribute to fire growth or to the fully developed fire and they have no influence to the smoke hazard. In the context of this intended end use application, the plastic constituents embedded in concrete or masonry can be considered to satisfy any reaction to fire requirements. Where the plastic constituents of the anchor are embedded in the suspended ceiling membrane, which is not a product having a reaction to fire class A1 in accordance with EN 13501-1, the plastic constituents may be assumed not to influence the reaction to fire class of the suspended ceiling membrane.

I.4.6 Provisions accompanying performance declarations

Information accompanying performance declarations shall specify which product or kit components have been considered as small kit components that do not need to be tested. The manufacturer's technical documentation shall specify how the constituent is part of the product and/or how the product or kit component is incorporated in the works.

Annex J (normative)

Mechanical strength, safety against failure – baffles

J.1 General

This annex deals with baffles, i.e. vertical hanging membrane components suspended at one or more points. The annex describes a test method for determining the strength of the baffle under different environmental conditions.

The purpose of the test is to determine whether a baffle and its supporting device/detail have sufficient strength to support its own weight when installed.

J.2 Test equipment

J.2.1 Loading brackets

U-shaped steel profiles made of flat iron having a width of 50 mm and a thickness of at least 3 mm shall be used. The distance between the legs shall be adjusted to fit the actual width of the baffle to be tested. The legs shall be long enough in order to facilitate the connection of the loading device.

J.2.2 Conditioning chamber

The test room/chamber which is hosting the test frame with the specimen shall be equipped with a system able to control the climate with respect to temperature, moisture content of the air and relative humidity.

It shall be possible to control the temperature between 20 °C to 40 °C with an accuracy of at least ± 2 °C. It shall be possible to control the moisture content of the air between 3 g/kg of dry air and 20 g/kg of dry air with an accuracy of at least ± 5 %.

J.2.3 Loading device

Equipment for loading the test specimen.

Weights or a mechanical/ hydraulic loading device with an accuracy of ± 5 %.

J.3 Test specimen

The test specimen shall consist of a baffle including its supporting device that is connecting the baffle membrane to the top fixing or the suspension. The test specimen shall be representative of the baffle used in practice.

J.4 Number of specimen

Five tests per type and size of baffles shall be carried out.

J.5 Conditioning

Before initiating conditioning, the test specimen shall be stored, without packaging, in normal laboratory conditions for at least 12 h.

Before commencing the test the specimens shall pass through the following conditioning:

Bring to equilibrium with the limit conditions specified for the class of exposure, see Table 8, for example at 25 °C combined with 70 % RH or 30 °C combined with 90 % RH. This shall be considered to have been accomplished when the difference in weight (mass) between two successive weightings 24 h apart is not greater than 1 %.

All specimens intended for testing plus an additional specimen for assessment of weight stabilization shall be subjected to conditioning. During conditioning the specimen shall be installed vertically or horizontally but separated with at least 5mm spacing, allowing air circulation on all surfaces.

After meeting the weight stabilization criteria, the (numbered) specimens shall be placed in the test frame.

Conditioning of the test specimen is not required when the material from which the membrane component is made is impervious to dampness or humidity (e.g. metals).

J.6 Test set up (see Figure J.1)

The test specimen shall be hung from a supporting construction as in practice. The supporting construction, the top fixing and any type of suspension that not is a part of the baffle, shall be chosen and designed so that they do not influence the test and the test result. Only the baffle and its supporting device shall be evaluated by the test.

The supporting construction, the top fixing and any type of suspension shall therefore have sufficient strength and stiffness in order not to influence the test and test result.

The load shall be applied as point load centred (with respect to the width of the baffle) under the baffle. The load shall be transferred to the baffle by means of the loading brackets.

A loading bracket shall be placed as close as possible to each supporting device of the baffle. The brackets shall be placed at the side of the supporting device closest to the centre of the baffle. If the supporting device is placed at the centre of the baffle, then the loading bracket shall be placed on any side of that supporting device.

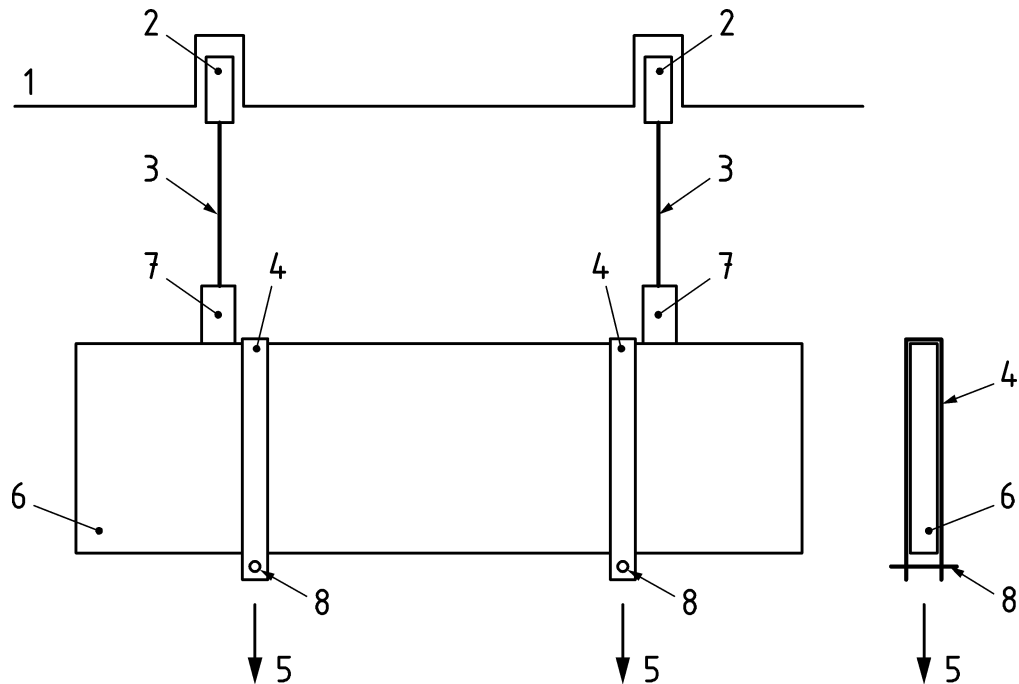

Key

- 1 supporting construction
- 2 top fixing
- 3 suspension
- 4 loading bracket
- 5 loading device
- 6 baffle membrane component
- 7 baffle supporting device/detail
- 8 pin for connecting loading device

Figure J.1 — Principle test set up for baffles

J.7 Test procedure

Apply the load at each loading bracket simultaneously. Increase the load in steps until collapse of the specimen occurs. Collapse is defined as total failure, i.e. the specimen lets go from the suspension **or** if one or more supporting devices is loosening from the baffle.

The time between every load step shall not be less than 60 s.

The load rate shall be established as follows:

- a preliminary test shall take place until collapse of the specimen;
- the load determined shall then be divided by 20;
- the value established in this way shall then be considered as steps to increase the load in the official test.

J.8 Performance criteria, assessment, evaluation and expression of the test result

A baffle and its supporting device/detail shall be assessed to have sufficient strength to carry its own mass without falling down when hung in a substructure or any other fixing device, in a specified exposure class according to Table 8, when the baffle is able to carry at least 2,5 times its dead weight.

EXAMPLE A baffle with the size (300 × 1500 × 30) mm and density of 200 kg/m³ carries $2,5 \times (0,3 \times 1,5 \times 0,03 \times 200 \times 9,81) = 66,2$ N without collapsing.

All five test specimen shall pass the test. When one or more of the specimen of the original series fails the test, an additional 5 specimen shall be tested and all the 5 subsequent samples shall meet the requirement.

J.9 Test report

The test report shall contain the following information:

- manufacturer and manufacturing plant;
- identification of the product (description and physical characteristics);
- information about traceability of the products;
- information about the sampling:
 - date and time of sampling;
 - production line or unit;
 - personnel involved in sampling;
 - applied sampling method, if any;
- identification of the organization and personnel executing the test;
- applied test method:
 - test conditions and configuration;
 - number of test performed;
- place and date of testing;
- test results, including analysis of these (when relevant):
 - evaluation of test results according to J.8;
- place and date of delivery of the test report;
- registration number of the testing laboratory (where relevant);
- signature of the head of the testing laboratory and stamp.

Annex K (informative)

Reaction to fire performance - Classified without the need for further testing (CWFT)

The reaction to fire class of a component or material of suspended ceiling, which meets the requirements of the following table may be determined without the need for further testing (CWFT) and declared as given therein.

NOTE Directive 89/106/EEC envisages that in order to take account of different levels of protection for the construction works at national, regional or local levels, it may be necessary to establish in the interpretative documents classes corresponding to the performance of products in respect of each essential requirement. Those documents have been published as the 'Communication of the Commission with regard to the interpretative documents of Directive 89/106/EEC'.

With respect to the essential requirement of safety in the event of fire, interpretative document No 2 lists a number of interrelated measures which together define the fire safety strategy to be variously developed in the Member States. Interpretative document No 2 identifies one of those measures as the limitation of the generation and spread of fire and smoke within a given area by limiting the potential of construction products to contribute to the full development of a fire. The level of that limitation may be expressed only in terms of the different levels of reaction-to-fire performance of the products in their end-use application.

By way of a harmonized solution, a system of classes was adopted in Commission Decision 2000/147/EC of 8 February 2000 implementing Council Directive 89/106/EEC as regards the classification of the reaction-to-fire performance of construction products. In the case of products covered by this European Standard, it is necessary to use the classification established in Decision 2000/147/EC.

The reaction-to-fire performance of many construction products and/or materials, within the classification provided for in Decision 2000/147/EC, is well established and sufficiently well known to fire regulators in Member States that they do not require testing for this particular performance characteristic.

The measures provided for in this annex are in accordance with the referenced European Commission Decisions. The products which satisfy all the requirements of the performance characteristic 'reaction-to-fire' without need for further testing and the specific classes to be applied to within the reaction-to-fire classification adopted in Decision 2000/147/EC, are set out in this annex.

Products should be considered in relation to their end-use application, where relevant.

Table K.1⁶⁾ — Classes of reaction to fire performance for air drying jointing compounds

Product ⁽¹⁾	Product details for the jointing system	Maximum organic content (% in weight)	Class ⁽²⁾
Air drying jointing compounds for gypsum plasterboards used together with paper jointing tape. Paste ready to use or powder to be mixed with water, on any substrate of at least class A2-s1,d0 with thickness at least 6 mm and with density at least 700 kg/m ³ (excluding floorings).	Air drying jointing compounds of types 1A, 2A and 3A and paper jointing tape ⁽³⁾ according to EN 13963	7,0	A2-s1,d0
<p>(1) Wet density of the jointing compound at least 1,1 kg/litre (1 100 kg/m³).</p> <p>(2) Class as provided for in Table 1 of the annex to Commission Decision 2000/147/EC.</p> <p>(3) Maximum width of the paper jointing tape: 55 mm; maximum mass of the paper jointing tape per unit area: 135 g/m².</p>			

6) This table is the same as Table of the Commission Decision 2010/83/EU of 2010-02-09 (see *OJEU L038 of 2010-02-11*).

Annex L (informative)

Guidance on the choice of attestation of conformity system

When considering a choice of the attestation of conformity systems that correspond with the reaction to fire class claimed, it is the manufacturer who is responsible for the decision which attestation of conformity system applies for the product under consideration, taking into account the production process. Third parties can only offer advice. Since manufacturers need to be able to demonstrate (to market surveillance authorities) why certain decisions were made, it is good practice for manufacturers to collect all relevant data in their technical documentation, which is the set of documents that substantiates the manufacturer's declaration of conformity. When deciding on the system to be used, manufacturers should always be in a position to demonstrate why the decisions they took were taken.

Footnote (*) in Table ZA.2 specifies that an attestation of conformity system with more notified body involvement is to be chosen when a clearly identifiable stage in the production process results in an improvement of the reaction to fire classification.

In the cases where a notified certification body is involved (attestation of conformity system 1), the notified certification body is responsible for ensuring that the samples tested are representative for the product placed on the market, otherwise, the manufacturer assumes this responsibility. In both cases, a sampling report needs to be established.

If fire retardants are added, the product should in any case be subjected to attestation of conformity system 1 (see Figure L.3).

If manufacturers limit the organic content of their products, and production control ensures that, even if production meets the extremes of the production tolerances, the organic content is far from reaching the point where the product would be in a different (i.e. lower) reaction to fire class, then the product may be considered to be subject to attestation of conformity system 3. If the organic content may be close to reaching that point, then the product should be subject to attestation of conformity system 1. Alternatively, manufacturers may decide to declare the lower reaction to fire class, allowing the product to be subjected to attestation of conformity system 3. The Figures L.1, L.2 and L.3 illustrate the above.

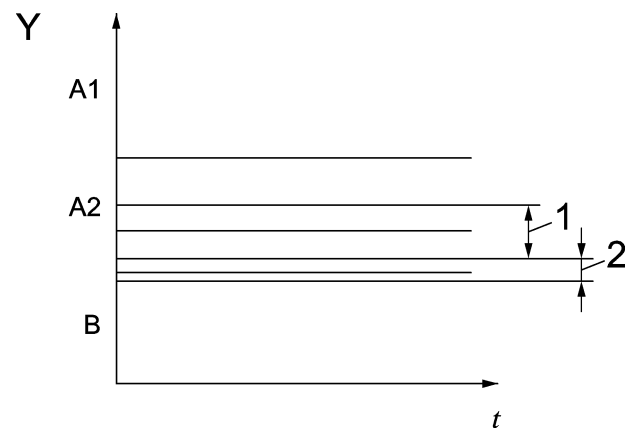
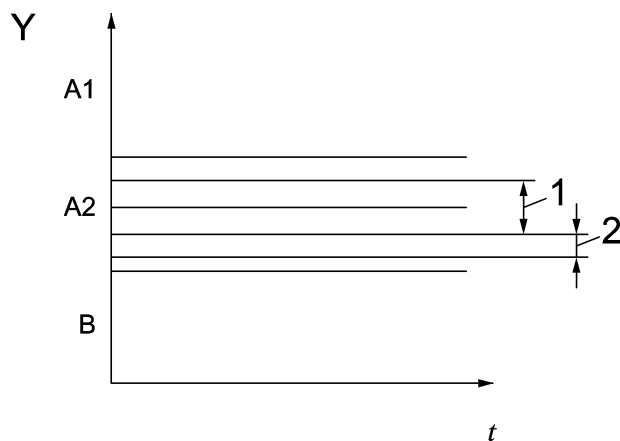

Key

Y	Reaction to fire class
<i>t</i>	Time
A1, A2, B	Examples of reaction to fire classes

Figure L.1 — Taking into consideration production tolerances and the safety factor, it is reasonable to assume that the risk of the product having a reaction to fire class B, rather than the class claimed, is small. Therefore attestation of conformity system 3 should be used.

Figure L.2 — Taking into consideration production tolerances and the safety factor, it is reasonable to assume that the risk of the product having a reaction to fire class B, rather than the class claimed, exists. Therefore, either the manufacturer claims reaction to fire class B under attestation of conformity system 3, or he claims class A2, subject to attestation of conformity system 1 being used.

The choice of attestation of conformity system due to the manufacturer's claimed reaction to fire performance is, therefore, related to the likelihood:

- that the product would have a reaction to fire class that is lower than the one claimed if something goes wrong during production; and
- of errors in the production process and therefore to the FPC system used.

If the reaction to fire test results place the product far from the lower class and if the manufacturer has a FPC system making it unlikely that the finished product has a reaction to fire class that is lower than the one claimed, taking into account a safety factor, the manufacturer should use the attestation of conformity system 3, rather than 1. In any case, the manufacturer needs to ascertain that he has documented substantiation, filed in his technical documentation, demonstrating why he made that choice.

Given that the safety factor depends on the material involved and the production process, the manufacturer needs to decide on the safety factor referred to above.

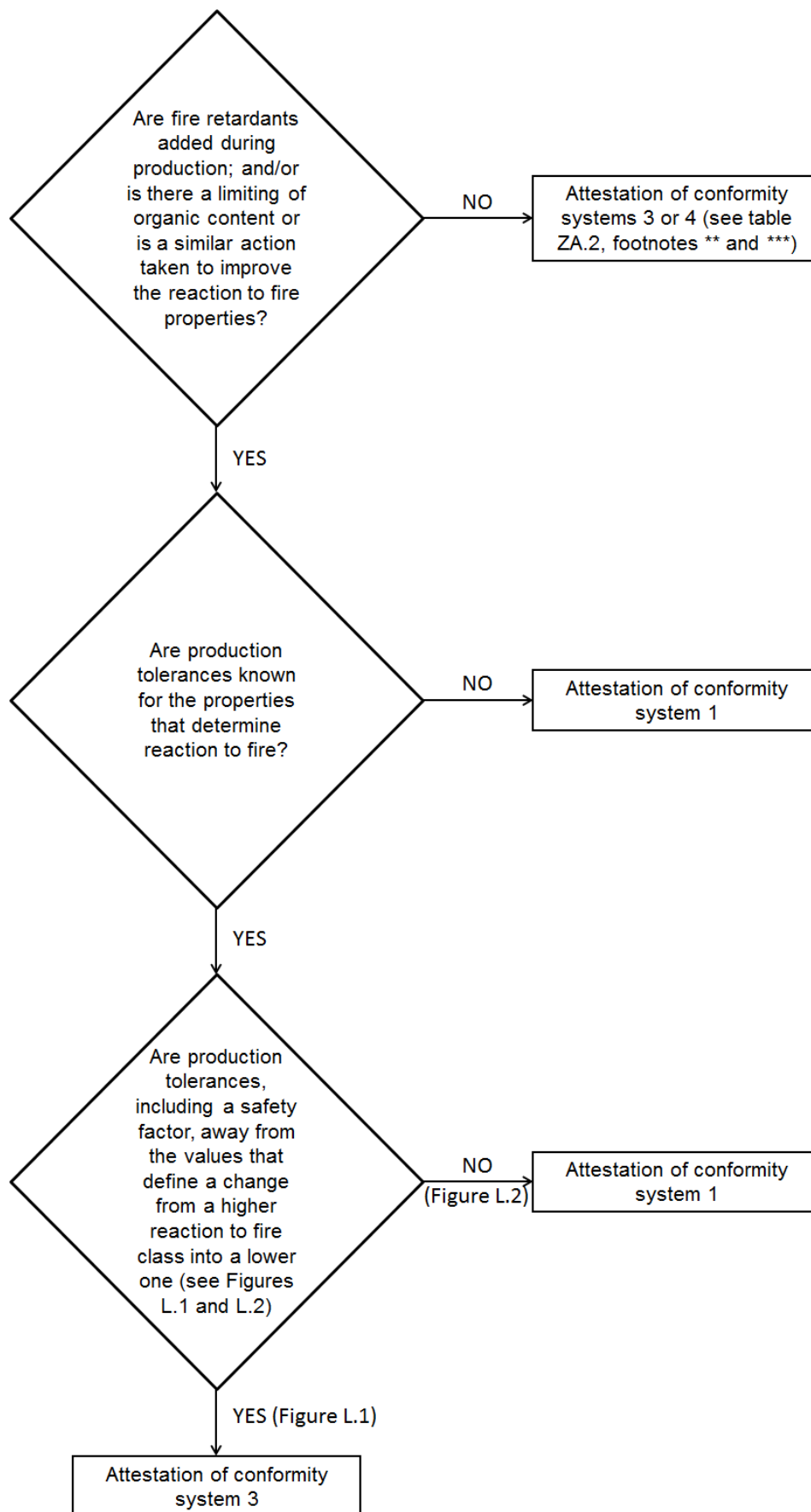

Figure L.3 - Flow chart demonstrating the decision making process

Annex M (informative)

Significant technical changes between this European Standard and the previous edition

Significant technical changes between this European Standard and the previous edition, including its amendment, include the following:

a) New clauses, subclauses, annexes, tables or figures:

- Tables 6, 11, 12 and 13;
- Annexes H, I, J, K, L and M (this one);
- Subclauses: 4.4.2.4, 4.8.6, 4.8.7, 5.3.2.2 and 5.3.2.3;

b) Modified clauses, subclauses, annexes, tables or figures:

- Clause 1;
- Tables 1, 3, 4, 5, 7 and 8;
- Annexes A, B, E, F and ZA;
- Figures 15 and 19;
- Subclauses: 3.3.2, 3.4.1, 4.1, 4.2, 4.3.2.1, 4.3.4, 4.4.1.1, 4.4.1.3, 4.4.2.2, 4.4.2.3, 4.4.2.4, 4.5.3, 4.6.2, 4.7.1, 4.7.4, 4.8.3, 4.10, 5.2.1, 5.2.4, 5.3.2, 5.3.4, 5.3.5, 6.1, 6.2.3, 6.3.3.2 and 7.1;

c) Deleted clauses, subclauses, annexes, tables or figures:

- Subclause 3.1.6;

d) Deleted normative references: EN 335-3, EN 520, EN 14190, EN 14195 and EN ISO 9001:2004;

e) New normative references: EN 335, EN 13162, EN 13171, EN 13245-1 and EN 13245-2;

f) New reference in Bibliography: EN ISO 9001:2008.

Annex ZA (informative)

Clauses of this European Standard addressing essential requirements or other provisions of EU Directives

ZA.1 Scope and relevant clauses

This European Standard has been prepared under Mandate M/121 "Internal and external wall and ceiling finishes" given to CEN by the European Commission and the European Free Trade Association.

The clauses of this European Standard shown in this annex meet the requirements of the mandate given under the EU Construction Products Directive (89/106/EEC).

Compliance with these clauses confers a presumption of fitness of the construction products covered by this annex for their intended uses indicated herein. Reference shall be made to the information given in the CE marking.

This annex establishes the conditions for the CE marking of the construction products intended for the uses indicated in Tables ZA.1.1 to ZA.1.4 and shows the relevant clauses applicable.

The scope of this annex is defined by Tables ZA.1.1 to ZA.1.4 and is the same as Clause 1 of this European Standard.

Table ZA.1.1 — Relevant clauses for suspended ceiling kits

Construction product: Suspended ceiling kits			
Intended uses: Internally in buildings, to produce installed suspended ceilings ^a			
Essential characteristics	Requirement clauses in this standard	Levels and/or classes	Notes
Reaction to fire ^b	4.4.2.1 and 4.4.2.4	Classes A1 to F	According to EN 13501-1
Fire resistance ^c	4.4.1	See EN 13501-2	According to EN 13501-2
Release of asbestos (content), where relevant ^d	4.5.1	-	Content and/or release-
Release of formaldehyde, where relevant	4.5.2	-	Classes E1 or E2
Release and/or content of other dangerous substances, where relevant	4.5.3 ^e	-	Content and/or release
Susceptibility to the growth of harmful micro-organisms, as dampness	4.5.4 ^f	-	Levels
Susceptibility to the growth of harmful micro-organisms, through thermal insulation	4.5.4 ^g	-	Levels
Shatter properties (safe breakage) ^h , as impact resistance	4.3.6	-	Levels
Shatter properties (safe breakage) ^h , as shatter properties	4.6.1	-	Levels
Flexural tensile strength ⁱ	4.6.2	-	Levels
Load bearing capacity ^j :			
- Substructure	4.3.2	-	Levels
- Suspension components and fasteners	4.3.3	-	Declaration of performance
- Top fixing of suspension components and perimeter trim fixings	4.3.4	-	Declaration of performance
- Tolerances and dimensions ^k	4.2	-	Declaration of performance
Resistance to fixings	4.3.4	-	Declaration of performance
Electrical safety	4.6.4	-	Statement of compliance
Direct airborne sound insulation ^l	4.7.3	-	Declaration of performance
Sound absorption ^m	4.7.2	-	Declaration of performance
Thermal performances, as thermal conductivity ⁿ	4.10	-	Declaration of performance

Table ZA.1.1 — Relevant clauses for suspended ceiling kits (continued)

Durability	4.8	-	Levels
<p>^a Not for suspended ceilings intended for uses in ceilings subject to water penetration requirements.</p> <p>^b For suspended ceilings intended for uses subject to reaction to fire regulations only.</p> <p>^c For suspended ceilings intended for fire protection uses only.</p> <p>^d For suspended ceilings membrane components made of fibre cement.</p> <p>^e See 4.5.3.</p> <p>^f With regard to loss of the flexural tensile strength of the membrane and/or loss of the load bearing capacity.</p> <p>^g With regard of preventing the conditions that may lead to the growth of harmful micro-organisms.</p> <p>^h For suspended ceiling membrane components only, when made of brittle materials intended for uses subject to requirements against accidental injuries from cutting objects.</p> <p>ⁱ For suspended ceiling membrane components of the kit only.</p> <p>^j For suspended ceiling substructure kits and suspended ceiling substructure components only.</p> <p>^k But not dimensions themselves and only for the suspended ceiling frame, whether made of substructure kit or its substructure components, and for the suspended ceiling membrane components.</p> <p>^l For suspended ceilings intended for uses in ceilings subject to acoustic insulation requirements.</p> <p>^m For suspended ceilings intended for uses in ceilings subject to acoustic conditioning requirements.</p> <p>ⁿ For suspended ceilings intended for uses in ceilings subject to thermal insulation requirements.</p>			

Table ZA.1.2 — Relevant clauses for suspended ceiling substructure kits

Construction product:	Suspended ceiling substructure kits		
Intended uses:	Internally in buildings, to produce installed suspended ceilings ^a		
Essential characteristics	Requirement clauses in this standard	Levels and/or classes	Notes
Reaction to fire ^b	4.4.2.3	Classes A1 to F	According to EN 13501-1
Load bearing capacity:			
- Substructure	4.3.2, 4.3.3 and 4.3.4, as relevant	-	Levels
- Tolerances and dimensions ^c	4.2	-	Declaration of performance
Resistance to fixings	4.3.4	-	Declaration of performance
Electrical safety	4.6.4	-	Statement of compliance
Durability	4.8	-	Levels
<p>^a Not for suspended ceilings intended for uses in ceilings subject to water penetration requirements.</p> <p>^b For suspended ceilings intended for uses subject to reaction to fire regulations only.</p> <p>^c But not dimensions themselves.</p>			

Table ZA.1.3 — Relevant clauses for suspended ceiling substructure components

Construction product: Suspended ceiling substructure components			
Intended uses: Internally in buildings, to produce the substructure of installed suspended ceilings ^a			
Essential characteristics	Requirement clauses in this standard	Levels and/or classes	Notes
Reaction to fire ^b	4.4.2.3	Classes A1 to F	According to EN 13501-1
Load bearing capacity:			
- Substructure	4.3.2	-	Levels
- Suspension components and fasteners	4.3.3	-	Declaration of performance
- Top fixing of suspension components and perimeter trim fixings	4.3.4	-	Declaration of performance
- Tolerances and dimensions ^c	4.2	-	Declaration of performance
Resistance to fixings	4.3.4	-	Declaration of performance
Durability	4.8	-	Levels
^a Not for suspended ceilings intended for uses in ceilings subject to water penetration requirements. ^b For suspended ceilings intended for uses subject to reaction to fire regulations only. ^c But not dimensions themselves.			

Table ZA.1.4 — Relevant clauses for suspended ceiling membrane components

Construction product: Suspended ceiling membrane components			
Intended uses: Internally in buildings, to produce installed suspended ceilings ^a			
Essential characteristic	Requirement clauses in this standard	Levels and/or classes	Notes
Reaction to fire ^b	4.4.2.2	Classes A1 to F	According to EN 13501-1
Release of asbestos (content), where relevant ^c	4.5.1	-	Content and/or release-
Release of formaldehyde, where relevant	4.5.2	-	Classes E1 or E2
Release and/or content of other dangerous substances, where relevant	4.5.3 ^d	-	Content and/or release-
Susceptibility to the growth of harmful micro-organisms, as dampness	4.5.4 ^e	-	Levels
Susceptibility to the growth of harmful micro-organisms, through thermal insulation	4.5.4 ^f	-	Levels
Shatter properties (safe breakage) ^g , as impact resistance	4.3.6	-	Levels
Shatter properties (safe breakage) ^g , as shatter properties	4.6.1	-	Levels
Flexural tensile strength	4.6.2	-	Levels
Bond strength/adhesion, as resistance to fixings	4.3.4	-	Declaration of performance
Sound absorption ^h	4.7.2	-	Declaration of performance
Thermal resistance (e.g. density), as thermal conductivity ⁱ	4.10	-	Declaration of performance
Durability	4.8	-	Levels

^a Not for suspended ceilings intended for uses in ceilings subject to water vapour control requirements or water penetration requirements.

^b For suspended ceilings intended for uses subject to reaction to fire regulations only.

^c Only when made of fibre cement.

^d See 4.5.3.

^e With regard to loss of the flexural tensile strength of the membrane and/or loss of the load-bearing capacity.

^f With regard of preventing the conditions that may lead to the growth of harmful micro-organisms.

^g Only when made of brittle materials intended for uses subject to requirements against accidental injuries from cutting objects.

^h For suspended ceilings intended for uses subject to acoustic conditioning requirements.

ⁱ For suspended ceilings intended for uses subject to thermal insulation requirements.

The requirement on a certain characteristic, shown in Tables ZA.1.1 to ZA.1.4, is not applicable in those Member States (MSs) where there are no regulatory requirements on that characteristic for the intended use of the product. In this case, manufacturers placing their products on the market of these MSs are not obliged to determine nor declare the performance of their products with regard to this characteristic and the option "No Performance Determined" (NPD) in the information accompanying the CE marking (see ZA.3) may be used.

ZA.2 Procedure for attestation of conformity

ZA.2.1 Systems of attestation of conformity

The systems of attestation of conformity of suspended ceiling kits, indicated in Table ZA.1.1, of suspended ceiling substructure kits, indicated in Table ZA.1.2, of suspended ceiling substructure components (referred to as "suspending frames" in Table ZA.2), indicated in Table ZA.1.3 and/or of suspended ceiling membrane components (referred to as "tiles, panels" in Table 2), indicated in Table ZA.1.4, in accordance with the Annex III of the Mandate M/121 for internal and external wall and ceiling finishes as modified by Decision of the Commission 98/437/EC of 1998-06-30 (see *OJEU L194 of 1998-07-10*), as corrected (see *OJEU L278 of 1998-10-15*) and amended by 2001/596/EC of 2001-01-08 (see *OJEU L209 of 2001-08-02*), are shown in Table ZA.2 for the indicated intended uses and relevant level(s) or classes.

Table ZA.2 — Systems of attestation of conformity for suspended ceiling kits, for suspended ceiling substructure kits, for suspended ceiling substructure components and for suspended ceiling membrane components

Products	Intended uses	Level(s) or class(es)	Attestation of conformity systems
Suspended ceilings (kits)	As internal finishes in ceilings used for fire protection of ceilings	Any	3
	As internal finish in ceilings subject to safety in use requirements	–	3
	As internal finishes in ceilings subject to reaction to fire regulations	A1*, A2*, B* and C*	1
		(A1, A2, B, C)**, D and E	3
		(A1 to E)***, F	4
As internal finishes in ceilings subject to regulations on dangerous substances ¹	–	3	
As internal finishes in ceilings for all other uses mentioned in the mandate ²	–	4	
Suspending frames	To support internal suspended ceilings subject to safety in use requirements	–	3
	To support internal suspended ceilings subject to reaction to fire regulations	A1*, A2*, B* and C*	1
		(A1, A2, B, C)**, D and E (A1 to E)***, F	3 4
To support internal suspended ceilings for all other uses mentioned in the mandate ²	–	4	
Tiles, panels	To support internal suspended ceilings subject to safety in use requirements	–	3
	As internal finish in ceilings subject to requirements against accidental injuries from cutting objects ³		
	As internal finishes in ceilings subject to reaction to fire regulations	A1*, A2*, B* and C*	1
		(A1, A2, B, C)**, D and E	3
		(A1 to E)***, F	4
As internal finishes in ceilings subject to regulations on dangerous substances ¹	–	3	
As internal finishes in ceilings for all other uses mentioned in the mandate ²	–	4	
<p>* Products/materials for which a clearly identifiable stage in the production process results in an improvement of the reaction to fire classification (e.g. an addition of fire retardants or a limiting of organic material).</p> <p>** Products/materials not covered by footnote (*).</p> <p>*** Products/materials that do not require to be tested for reaction to fire (e.g. products/materials of Class A1 according to Commission Decision 96/603/EC).</p> <p>System 1: See Directive 89/106/EEC (CPD) Annex III.2.(i), without audit testing of samples. System 3: See Directive 89/106/EEC (CPD) Annex III.2.(ii), Second possibility. System 4: See Directive 89/106/EEC (CPD) Annex III.2.(ii), Third possibility.</p>			
<p>1 In particular, those dangerous substances defined in Council Directive 76/769/EEC, as amended.</p> <p>2 Other intended uses covered by the mandate are: for vapour control, for water penetration control, for acoustic control and for thermal control.</p> <p>3 For tiles or panels made of brittle materials.</p>			

NOTE See Annex L for guidance on the choice of attestation of conformity system with regard to the reaction to fire.

The attestation of conformity of suspended ceiling kits, indicated in Table ZA.1.1, of suspended ceiling substructure kits, indicated in Table ZA.1.2, of suspended ceiling substructure components, indicated in Table ZA.1.3 and/or of suspended ceiling membrane components, indicated in Table ZA.1.4, shall be according to the evaluation of conformity procedures indicated in Tables ZA.3.1 to ZA.3.3, as applicable, resulting from application of the clauses of this standard indicated therein.

Table ZA.3.1 — Assignment of evaluation of conformity tasks for suspended ceiling kits, suspended ceiling substructure kits, suspended ceiling substructure components and/or suspended ceiling membrane components under system 1

Tasks		Content of the task	Evaluation of conformity clauses to apply
Tasks under the responsibility of the manufacturer	Factory production control (FPC)		
	Further testing of samples taken at the factory	Reaction to fire (Classes A1*, A2*, B*, C*) ^a	
	Initial type testing	Reaction to fire (Classes A1*, A2*, B*, C*) ^a	6.2
Tasks under the responsibility of the notified certification body	Initial inspection of factory and of FPC	Parameters related to characteristics of Tables ZA.1.1, ZA.1.2, ZA.1.3 or ZA.1.4 relevant for the intended use (see note), for which performances are being declared, namely reaction to fire (for classes above)	6.3.4
	Continuous surveillance, assessment and approval of FPC	Parameters related to characteristics of Tables ZA.1.1, ZA.1.2, ZA.1.3 or ZA.1.4 relevant for the intended use (see note), for which performances are being declared, namely reaction to fire for classes above	6.3.5
NOTE This table refers exclusively to tasks required for products intended for uses subject to reaction to fire regulations for the classes indicated herein. For products intended for other uses or for uses subject to reaction to fire regulations but for other classes, the tasks of the notified body, derived from the relevant systems of attestation of conformity, are cumulative, as relevant.			
^a See footnote (*) to Table ZA.2.			

Table ZA.3.3 — Assignment of evaluation of conformity tasks for suspended ceiling kits, suspended ceiling substructure kits, suspended ceiling substructure components and/or suspended ceiling membrane components under system 4

Tasks		Content of the task	Evaluation of conformity clauses to apply
Tasks under the responsibility of the manufacturer	<p>Factory production control (FPC)</p> <p>Initial type testing by the manufacturer</p>		
<p>NOTE This table refers exclusively to tasks required for products intended for uses different to those mentioned in previous tables as well as for products intended for uses subject to reaction to fire regulations of the classes of note (***) to Table ZA.2. For products intended for other uses or for uses subject to reaction to fire regulations but for other classes, the tasks of the notified body, derived from the relevant systems of attestation of conformity, are cumulative, as relevant.</p>			

ZA.2.2 EC certificate of conformity and EC declaration of conformity

ZA.2.2.1 For products under system 1

NOTE 1 Relevant for a product (see Tables ZA.1.1, ZA.1.2, ZA.1.3 and/or ZA.1.4), for which intended use the attestation of conformity system 1 (see Table ZA.3.1) applies with regard to one characteristic.

When compliance with the conditions of this annex is achieved, the certification body shall draw up a certificate of conformity (i.e. EC certificate of conformity), which entitles the manufacturer to affix the CE marking. The certificate shall include:

- name, address and identification number of the certification body;
- name and address of the manufacturer, or his authorized representative established in the EEA, and place of production;

NOTE 2 The manufacturer may also be the person responsible for placing the product onto the EEA market, if he takes responsibility for CE-marking.

- description of the product (type, identification, use);
- provisions to which the product conforms (i.e. Annex ZA of this EN);
- particular conditions applicable to the use of the product (e.g. provisions for use under certain conditions);
- the number of the certificate;
- conditions and period of validity of the certificate, where applicable;
- name of, and position held by, the person empowered to sign the certificate.

The above-mentioned EC certificate of conformity shall be presented in the language or languages accepted in the Member State in which the product is intended to be used.

ZA.2.2.2 For products under system 3

NOTE 1 Relevant for a product (see Tables ZA.1.1, ZA.1.2, ZA.1.3 and/or ZA.1.4), for which intended use the attestation of conformity system 3 (see Table ZA.3.2) applies with regard to one or more characteristics.

When compliance with the conditions of this annex is achieved, the manufacturer or his agent established in the EEA shall prepare and retain a declaration of conformity (i.e. EC declaration of conformity), which entitles the manufacturer to affix the CE marking. This declaration shall include:

- name and address of the manufacturer, or his authorized representative established in the EEA, and place of production;

NOTE 2 The manufacturer may also be the person responsible for placing the product onto the EEA market, if he takes responsibility for CE-marking.

- description of the product (type, identification, use etc.), and a copy of the information accompanying the CE marking;

NOTE 3 Where some of the information required for the declaration of conformity is already given in the CE-marking, it does not need to be repeated.

- provisions to which the product conforms (i.e. Annex ZA of this EN), and a reference to the ITT report(s) and factory production control records, as appropriate;

NOTE 4 When assessment of the reaction to fire performance falls under attestation of conformity system 1 and the performance of other essential characteristics are declared, the EC declaration of conformity, prepared according to this subclause, may include reference to EC certificate of conformity (on reaction to fire class), as prepared according to ZA.2.2.1.

- particular conditions applicable to the use of the product, (e.g. provisions for use under certain conditions, etc.);

NOTE 5 Information on the product or kit components, which have been considered as small kit components and that do not need to be tested (see I.4.6) may be specified in the accompanying document to the EC declaration of conformity, prepared under this subclause.

- name and address of the notified laboratory(ies);
- name of, and position held by, the person empowered to sign the declaration on behalf of the manufacturer or his authorized representative.

The above mentioned EC declaration of conformity shall be presented in the language or languages accepted in the Member State in which the product is intended to be used.

ZA.2.2.3 For products under system 4

NOTE 1 Relevant for a product (see Tables ZA.1.1, ZA.1.2, ZA.1.3 and/or ZA.1.4), for which intended use the attestation of conformity system 4 (see Table ZA.3.3) applies with regard to one or more characteristics.

When compliance with this annex is achieved, the manufacturer or his agent established in the EEA shall prepare and retain a declaration of conformity (i.e. EC declaration of conformity), which entitles the manufacturer to affix the CE marking. This declaration shall include:

- name and address of the manufacturer, or his authorized representative established in the EEA, and place of production;

NOTE 2 The manufacturer may also be the person responsible for placing the product onto the EEA market, if he takes responsibility for CE-marking.

- description of the product (type, identification, use,...), and a copy of the information accompanying the CE marking;

NOTE 3 Where some of the information required for the declaration of conformity is already given in the CE-marking, it does not need to be repeated.

- provisions to which the product conforms (i.e. Annex ZA of this EN), and a reference to the ITT report(s) and factory production control records, as appropriate;

NOTE 4 When assessment of the reaction to fire performance falls under attestation of conformity system 1 and the performance of other essential characteristics are declared, the EC declaration of conformity, prepared according to this subclause, may include reference to EC certificate of conformity (on reaction to fire class), as prepared according to ZA.2.2.1.

- particular conditions applicable to the use of the product (e.g. provisions for use under certain conditions);
- name of, and position held by, the person empowered to sign the declaration on behalf of the manufacturer or of his authorized representative.

The above mentioned EC declaration of conformity shall be presented in the language or languages accepted in the Member State in which the product is intended to be used.

ZA.3 CE marking

ZA.3.1 General

The manufacturer or his authorized representative established within the EEA is responsible for the affixing of the CE marking. The CE marking symbol shall be in accordance with Directive 93/68/EEC and shall be shown, considering the hierarchy of possibilities, on the product itself, and if not possible, on the label attached to it, on the packaging, or on the accompanying commercial documents (e.g. a delivery note). The following information shall accompany the CE marking symbol:

- a) identification number of the notified certification body (*only for products under system 1*);
- b) name or identifying mark of the manufacturer (see NOTE 2 to ZA.2.2.1 to ZA.2.2.3);

NOTE 1 Registered address of the manufacturer can also be added.

- c) last two digits of the year in which the marking is affixed;
- d) number of the EC certificate of conformity (*only for products under system 1*);
- e) reference to this European Standard and, if applicable, amendments to this standard, and the year of its publication (i.e. EN 13964:2014);
- f) description of the product, i.e.:
 - 1) generic name: suspended ceilings kit, suspended ceiling substructure kit, suspended ceiling substructure component or suspended ceiling membrane component; and
 - 2) intended use: for use internally in buildings;
- g) performances on those essential characteristics of product, listed in Tables ZA.1.1, ZA.1.2, ZA.1.3 or ZA.1.4, to be presented as:
 - 1) declared values and, where relevant, as class, including "Pass" for pass/fail requirements (where necessary), as indicated in "Notes" in Tables ZA.1.1 to ZA.1.4;

NOTE 2 The examples of CE marking, together with declared performances for the relevant essential characteristics, are given in ZA.3.2.1 to ZA.3.2.3 for the suspended ceiling product to conform only to this European Standard. In addition, in ZA.3.3.2 and ZA.3.3.3 are given similar examples for the suspended ceiling product to conform at the same time to this European Standard and to some other harmonized technical specifications (EN or European Technical Approval (ETA)).

- 2) or as "No performance determined" (i.e. NPD) for characteristic(s), where this is relevant.

The 'No performance determined' (NPD) option may be used when and where the characteristic, for a given intended use, is not subject to regulatory requirements in the Member State of intended destination of the product.

ZA.3.2 Examples of CE marking for suspended ceilings products according to EN 13964

ZA.3.2.1 Suspended ceiling kits

In addition to the information listed in ZA.3.1, a) to f), the performances for the following characteristics of the suspended ceiling kit or the different components of the kit shall accompany the CE marking symbol for the intended end uses (and where relevant):

Only the performances of those product's essential characteristics should be declared in CE marking, which are relevant for its specified intended use(s) (see the notes at the bottom of Tables ZA.1.1). Furthermore, the NPD option applies also, where relevant (see ZA.3.1).

- reaction to fire;
- resistance to fire;
- release of formaldehyde;
- release of asbestos (content);
- release and/or content of other dangerous substances;
- susceptibility to the growth of harmful micro-organisms, as:
 - dampness;
 - thermal insulation;
- shatter properties (safe breakage), as:
 - impact resistance;
 - shatter properties;
- flexural tensile strength (of the membrane components);
- load bearing capacity, as:
 - load bearing performance, for:
 - suspended substructure;
 - suspension components and fasteners;
 - top fixing of suspension components and perimeter trim fixings;
 - tolerances and dimensions;
- resistance to fixings;
- electrical safety;
- direct airborne sound insulation (e.g. density);
- sound absorption;
- thermal resistance (density), as thermal conductivity;
- durability (coating, if relevant, and exposure class).

Figure ZA.1 gives an example of the CE marking to be given on a suspended ceiling kit, on a label attached to it, on its packaging and/or in commercial documents, accompanying this suspended ceiling kit.

 4321	<p><i>CE conformity marking symbol given in Directive 93/68/EEC</i></p> <p><i>Identification number of the notified product certification body (only for products under system 1)</i></p>
<p>AnyCo Ltd</p> <p>14</p> <p>4321-CPD-00234</p>	<p><i>Name or identifying mark of the manufacturer</i></p> <p><i>NOTE 1 Registered address of the manufacturer may be added.</i></p> <p><i>Last two digits of the year in which the marking was affixed</i></p> <p><i>Number of the EC certificate of conformity (only for products under system 1)</i></p>
<p>EN 13964:2014</p> <p>Suspended ceiling kit for use internally in buildings</p>	<p><i>No. of European Standard and the year of its publication</i></p> <p><i>Description of the product and its intended use</i></p>
<p>Reaction to fire: Panels Class B-s1,d0 Substructure Class A1</p> <p>Fire resistance: NPD</p> <p>Release of asbestos (content): No release</p> <p>Release of formaldehyde: E1</p> <p>Release and/or content of other dangerous substances: Substance X No release</p> <p>Shatter properties:</p> <ul style="list-style-type: none"> - impact resistance: NPD - shatter properties: NPD <p>Flexural tensile strength: Class B/ no load</p> <p>Load bearing capacity:</p> <ul style="list-style-type: none"> - load bearing performance: (see attached - tolerances and dimensions: technical data sheet) (incl. a reference code) <p>Resistance to fixing: Pass</p> <p>Electrical safety: NPD</p> <p>Direct airborne sound insulation: NPD</p> <p>Sound absorption: $\alpha_w = 0,7$ (M)</p> <p>Thermal conductivity: $\lambda = 1,10$ W/m²K</p> <p>Susceptibility to the growth of harmful micro-organisms:</p> <ul style="list-style-type: none"> - Dampness: Pass - Thermal insulation: Pass <p>Durability: Corrosion protection acc. to EN 1396, Class 2a</p>	<p><i>Information on mandated characteristics</i></p> <p><i>NOTE 2 The relevant characteristics according to Table ZA.1.1.</i></p>

Figure ZA.1 — Example of CE marking for a suspended ceiling kit

ZA.3.2.2 Suspended ceiling substructure kits and substructure components

In addition to the information listed in ZA.3.1, a) to f), the performances for the following characteristics of the suspended ceiling kit or the different components of the kit shall accompany the CE marking symbol for the intended end uses (and where relevant):

NOTE 1 Only the performances of those product's essential characteristics should be declared in CE marking, which are relevant for its specified intended use(s) (see the notes at the bottom of Table ZA.1.2 or ZA.1.3). Furthermore, the NPD option applies also, where relevant (see ZA.3.1).

- reaction to fire;
- release and/or content of other dangerous substances;
- load bearing capacity, as:
 - load bearing performance, for:
 - suspended substructure;
 - suspension components and fasteners;
 - top fixing of suspension components and perimeter trim fixings;
 - tolerances and dimensions;
- resistance to fixings;
- durability (coating, if relevant, and exposure class).

Figure ZA.2 gives an example of CE marking to be given on the suspended ceiling substructure component, on a label attached to it, on its packaging and/or in commercial documents, accompanying this component.

NOTE 2 The same figure is also valid for CE marking of the suspended ceiling substructure kit.

 4321	<i>CE conformity marking symbol given in Directive 93/68/EEC</i> <i>Identification number of the notified product certification body (only for products under system 1)</i>																				
AnyCo Ltd 14 4321-CPD-00234	<i>Name or identifying mark of the manufacturer</i> <i>NOTE 1 Registered address of the manufacturer may be added.</i> <i>Last two digits of the year in which the marking was affixed</i> <i>Number of the EC certificate of conformity (only for products under system 1)</i>																				
<p style="text-align: center;">EN 13964:2014</p> <p style="text-align: center;">Suspended ceiling substructure component for use internally in buildings</p>	<p style="text-align: center;"><i>No. of European Standard and the year of its publication</i></p> <p style="text-align: center;"><i>Description of the product and its intended use</i></p>																				
<table border="0"> <tr> <td>Reaction to fire:</td> <td>Class A1</td> </tr> <tr> <td>Release and/or content of dangerous substances</td> <td>Substance Y: x ppm</td> </tr> <tr> <td>Load bearing capacity, as:</td> <td></td> </tr> <tr> <td>– load bearing performance:</td> <td></td> </tr> <tr> <td>– for suspended substructure</td> <td>(see attached technical data sheet) (incl. a reference code)</td> </tr> <tr> <td>– for suspension components and fasteners</td> <td></td> </tr> <tr> <td>– for top fixing of suspension components and perimeter trim fixings</td> <td></td> </tr> <tr> <td>– tolerances and dimensions</td> <td></td> </tr> <tr> <td>Resistance to fixing:</td> <td>Pass</td> </tr> <tr> <td>Durability:</td> <td>Corrosion protection acc. to EN 1396, Class 2a</td> </tr> </table>	Reaction to fire:	Class A1	Release and/or content of dangerous substances	Substance Y: x ppm	Load bearing capacity, as:		– load bearing performance:		– for suspended substructure	(see attached technical data sheet) (incl. a reference code)	– for suspension components and fasteners		– for top fixing of suspension components and perimeter trim fixings		– tolerances and dimensions		Resistance to fixing:	Pass	Durability:	Corrosion protection acc. to EN 1396, Class 2a	<p style="text-align: center;"><i>Information on mandated characteristics</i></p> <p style="text-align: center;"><i>NOTE 2 The relevant characteristics according to Table ZA.1.2. or ZA.1.3.</i></p>
Reaction to fire:	Class A1																				
Release and/or content of dangerous substances	Substance Y: x ppm																				
Load bearing capacity, as:																					
– load bearing performance:																					
– for suspended substructure	(see attached technical data sheet) (incl. a reference code)																				
– for suspension components and fasteners																					
– for top fixing of suspension components and perimeter trim fixings																					
– tolerances and dimensions																					
Resistance to fixing:	Pass																				
Durability:	Corrosion protection acc. to EN 1396, Class 2a																				

Figure ZA.2 — Example of CE marking for a suspended ceiling substructure component

ZA.3.2.3 Suspended ceiling membrane components

In addition to the information listed in ZA.3.1, a) to f), the performances for the following characteristics of the suspended ceiling kit or the different components of the kit shall accompany the CE marking symbol for the intended end uses (and where relevant):

NOTE Only the performances of those product's essential characteristics should be declared in CE marking, which are relevant for its specified intended use(s) (see the notes at the bottom of Table ZA.1.4). Furthermore, the NPD option applies also, where relevant (see ZA.3.1).

— reaction to fire;

- release of asbestos (content);
- release of formaldehyde;
- release and/or content of other dangerous substances;
- susceptibility to the growth of harmful micro-organisms, as:
 - dampness;
 - thermal insulation;
- shatter properties (safe breakage), as:
 - impact resistance;
 - shatter properties;
- flexural tensile strength (of the membrane components);
- bond strength/adhesion, as resistance to fixing;
- sound absorption;
- thermal resistance (density), as thermal conductivity;
- durability (coating, if relevant, and exposure class).

Figure ZA.3 gives an example of the CE marking to be given on the product, on a label attached to it, on a packaging and/or in commercial documents, accompanying the suspended ceiling membrane components.

 4321	<p><i>CE conformity marking symbol given in Directive 93/68/EEC</i></p> <p><i>Identification number of the notified product certification body (only for products under system 1)</i></p>
<p>AnyCo Ltd</p> <p>14</p> <p>4321-CPD-00234</p>	<p><i>Name or identifying mark of the manufacturer</i></p> <p><i>NOTE 1 Registered address of the manufacturer may be added.</i></p> <p><i>Last two digits of the year in which the marking was affixed</i></p> <p><i>Number of the EC certificate of conformity (only for products under system 1)</i></p>
<p>EN 13964:2014</p> <p>Suspended ceiling membrane component for use internally in buildings</p>	<p><i>No. of European Standard and the year of its publication</i></p> <p><i>Description of the product and its intended use</i></p>
<p>Reaction to fire: Class B-s1,d0</p> <p>Release of asbestos (content): No release</p> <p>Release of formaldehyde: E1</p> <p>Release and/or content of other dangerous substances: Substance Y: x ppm</p> <p>Shatter properties:</p> <ul style="list-style-type: none"> - impact resistance: NPD - shatter properties: NPD <p>Flexural tensile strength: Class B/ no load</p> <p>Bondstrength/adhesion: resistance to fixings: NPD</p> <p>Sound absorption: $\alpha_w = 0,7$ (M)</p> <p>Thermal conductivity: $\lambda_D = 0,038$ W/m·K</p> <p>Susceptibility to the growth of harmful micro-organisms:</p> <ul style="list-style-type: none"> - Dampness: Pass - Thermal insulation: Pass <p>Durability: Corrosion protection acc. to EN 1396, Class 2a</p>	<p><i>Information on mandated characteristics</i></p> <p><i>NOTE 2 The relevant characteristics according to Table ZA.1.4.</i></p>

Figure ZA.3 — Example of CE marking for a suspended ceiling membrane component

ZA.3.3 Examples of CE marking for products according to EN 13964 and at the same time according also to (an)other harmonized technical specification(s)

ZA.3.3.1 General

When a product has two (or more) different intended uses and CE marking is claimed for both uses and thus it complies with this European Standard and at the same time also to another harmonized technical specification(s), the CE marking may refer to both (or more) technical specifications and shall cover all requirements for information accompanying the CE marking from all referenced harmonized technical specifications.

EXAMPLE A suspended ceiling product complies with this European Standard (i.e. EN 13964) and at the same time:

- a) to one of the thermal insulation product standards (i.e. EN 13162 to EN 13171), or
- b) to a European Technical Approval (ETA) issued to the product as a fire protective board.

It is possible that, for different intended end uses, the system of attestation of conformity may be different (e.g. systems 2+ and 3). Where this is the case, the CE marking may not indicate or imply that performances for characteristics declared under a lower system of attestation (system 3) have been controlled under a higher system of attestation (system 2+). In these cases, different sets of information have to be presented separately in the CE marking.

Some information is communal (e.g. the CE marking symbol, name or identifying mark of the manufacturer) and needs to be presented on the labelling only once. Other information may be common in some cases: the number of the certification body (only if the AoC system applies in both cases and only a single body has been used), the EC certificate of conformity number (if a single certificate has been issued) and performances for characteristics where these have been assessed using the same test method and under the same attestation system.

ZA.3.3.2 Suspended ceiling membrane component according to EN 13964 and another EN

Figure ZA.4 gives an example of CE marking to be given on the suspended ceiling membrane component in accordance with EN 13964 and EN XXXXX), on a label attached to it, on its packaging and/or in commercial documents, accompanying the this component.

 4321		<i>CE conformity marking symbol given in Directive 93/68/EEC</i> <i>Identification number of the notified product certification body (only for products under system 1)</i>
AnyCo Ltd		<i>Name or identifying mark of the manufacturer</i> <small>NOTE 1 Registered address of the manufacturer may be added.</small>
14 4321-CPD-00234	08	<i>Last two digits of the year in which the marking was affixed</i> <i>Number of the EC certificate of conformity (only for products under system 1)</i>
EN 13964:2014 Suspended ceiling membrane component for use internally in buildings	EN XXXXX General building construction	<i>No. of European Standard and the year of its publication</i> <i>Description of the product and its intended use</i>
Reaction to fire: Class B-s1,d0 Release of asbestos (content): No release Release of formaldehyde: E1 Release and/or content of other dangerous substances X x ppm Shatter properties: - impact resistance: NPD - shatter properties: NPD Flexural tensile strength: Class B/ no load Bond strength/adhesion: resistance to fixings: NPD Sound absorption: $\alpha_w = 0,7$ (M) Thermal conduct.: $\lambda_D = 0,038$ W/m·K Susceptibility to the growth of harmful micro-organisms: - Dampness: Pass - Thermal insulation: Pass Durability: Class C	Characteristics to be declared as specified in Annex ZA of EN XXXXX	<i>Information on mandated characteristics</i> <small>NOTE 2 The relevant characteristics according to Table ZA.1.4 of EN 13964 and Table ZA.Y for EN XXXXX).</small>

Figure ZA.4 — Example of CE marking for a suspended ceiling membrane meeting both EN XXXXX and EN 13964 provisions (i.e. product under AoC system 1 for EN 13964 and system 3 for EN XXXXX)

Bibliography

- EN 520, *Gypsum plasterboards — Definitions, requirements and test methods*
- EN 1168, *Pre-cast concrete products — Hollow core slabs*
- EN 1520, *Prefabricated reinforced components of lightweight aggregate concrete with open structure with structural or non-structural reinforcement*
- EN 1992-2, *Eurocode 2: Design of concrete structures — Part 2: Concrete bridges — Design and detailing rules*
- EN 1993-1-1, *Eurocode 3: Design of steel structures — Part 1-1: General rules and rules for buildings*
- EN 10244-2, *Steel wire and wire products — Non-ferrous metallic coatings on steel wire — Part 2: Zinc or zinc alloy coatings*
- EN 12354-6, *Building acoustics — Estimation of acoustic performance of buildings from the performance of elements — Part 6: Sound absorption in enclosed spaces.*
- EN 12602, *Prefabricated reinforced components of autoclaved aerated concrete.*
- EN 13658-1, *Metal lath and beads — Definitions, requirements and test methods — Part 1: Internal plastering*
- EN 13963, *Jointing materials for gypsum plasterboards — Definitions, requirements and test methods*
- EN 13986, *Wood-based panels for use in construction — Characteristics, evaluation of conformity and marking*
- EN 14190, *Gypsum plasterboard products from reprocessing — Definitions, requirements and test methods*
- EN 14195, *Metal framing components for gypsum plasterboard systems — Definitions, requirements and test methods*
- EN 14246, *Gypsum elements for suspended ceilings — Definitions, requirements and test methods*
- EN 14566, *Mechanical fasteners for gypsum plasterboard systems — Definitions, requirements and test methods*
- EN 14716, *Stretched ceilings — Requirements and test methods*
- EN 15283-1, *Gypsum boards with fibrous reinforcement — Definitions, requirements and test methods — Part 1: Gypsum boards with mat reinforcement*
- EN 15283-2, *Gypsum boards with fibrous reinforcement — Definitions, requirements and test methods — Part 2: Gypsum fibre boards*
- HD 384, *Electrical installations of buildings*
- ETAG 001-1, *Metal anchors for use in concrete — Part 1: Anchors in general*
- ETAG 001-2, *Metal anchors for use in concrete — Part 2: Torque-controlled expansion anchors*
- ETAG 001-3, *Metal anchors for use in concrete — Part 3: Undercut anchors*
- ETAG 001-4, *Metal anchors for use in concrete — Part 4: Deformation-controlled expansion anchors*

ETAG 001-5, *Metal anchors for use in concrete — Part 5: Bonded anchors*

ETAG 001-6, *Metal anchors for use in concrete — Part 6: Anchors for multiple use for non-structural applications*

ETAG 018-4, *Fire protective products — Part 4: Fire protective board, slab and mat products and kits*

ETAG 020-1, *Plastic anchors — Part 1: General*

ETAG 020-2, *Plastic anchors — Part 2: Plastic anchors for use in normal weight concrete*

ETAG 020-3, *Plastic anchors — Part 3: Plastic anchors for use in solid masonry*

ETAG 020-4, *Plastic anchors — Part 4: Plastic anchors for use in hollow or perforated masonry*

ETAG 020-5, *Plastic anchors — Part 5: Plastic anchors for use in autoclaved aerated concrete (AAC)*

British Standards Institution (BSI)

BSI is the national body responsible for preparing British Standards and other standards-related publications, information and services.

BSI is incorporated by Royal Charter. British Standards and other standardization products are published by BSI Standards Limited.

About us

We bring together business, industry, government, consumers, innovators and others to shape their combined experience and expertise into standards-based solutions.

The knowledge embodied in our standards has been carefully assembled in a dependable format and refined through our open consultation process. Organizations of all sizes and across all sectors choose standards to help them achieve their goals.

Information on standards

We can provide you with the knowledge that your organization needs to succeed. Find out more about British Standards by visiting our website at bsigroup.com/standards or contacting our Customer Services team or Knowledge Centre.

Buying standards

You can buy and download PDF versions of BSI publications, including British and adopted European and international standards, through our website at bsigroup.com/shop, where hard copies can also be purchased.

If you need international and foreign standards from other Standards Development Organizations, hard copies can be ordered from our Customer Services team.

Subscriptions

Our range of subscription services are designed to make using standards easier for you. For further information on our subscription products go to bsigroup.com/subscriptions.

With **British Standards Online (BSOL)** you'll have instant access to over 55,000 British and adopted European and international standards from your desktop. It's available 24/7 and is refreshed daily so you'll always be up to date.

You can keep in touch with standards developments and receive substantial discounts on the purchase price of standards, both in single copy and subscription format, by becoming a **BSI Subscribing Member**.

PLUS is an updating service exclusive to BSI Subscribing Members. You will automatically receive the latest hard copy of your standards when they're revised or replaced.

To find out more about becoming a BSI Subscribing Member and the benefits of membership, please visit bsigroup.com/shop.

With a **Multi-User Network Licence (MUNL)** you are able to host standards publications on your intranet. Licences can cover as few or as many users as you wish. With updates supplied as soon as they're available, you can be sure your documentation is current. For further information, email bsmusales@bsigroup.com.

BSI Group Headquarters

389 Chiswick High Road London W4 4AL UK

Revisions

Our British Standards and other publications are updated by amendment or revision.

We continually improve the quality of our products and services to benefit your business. If you find an inaccuracy or ambiguity within a British Standard or other BSI publication please inform the Knowledge Centre.

Copyright

All the data, software and documentation set out in all British Standards and other BSI publications are the property of and copyrighted by BSI, or some person or entity that owns copyright in the information used (such as the international standardization bodies) and has formally licensed such information to BSI for commercial publication and use. Except as permitted under the Copyright, Designs and Patents Act 1988 no extract may be reproduced, stored in a retrieval system or transmitted in any form or by any means – electronic, photocopying, recording or otherwise – without prior written permission from BSI. Details and advice can be obtained from the Copyright & Licensing Department.

Useful Contacts:

Customer Services

Tel: +44 845 086 9001

Email (orders): orders@bsigroup.com

Email (enquiries): cservices@bsigroup.com

Subscriptions

Tel: +44 845 086 9001

Email: subscriptions@bsigroup.com

Knowledge Centre

Tel: +44 20 8996 7004

Email: knowledgecentre@bsigroup.com

Copyright & Licensing

Tel: +44 20 8996 7070

Email: copyright@bsigroup.com



...making excellence a habit.™