

Explosives for civil uses — Propellants and rocket propellants —

Part 4: Determination of burning rate under ambient conditions

The European Standard EN 13938-4:2003 has the status of a
British Standard

ICS 71.100.30

National foreword

This British Standard is the official English language version of EN 13938-4:2003.

The UK participation in its preparation was entrusted to Technical Committee CII/61, Explosives for civil uses, which has the responsibility to:

- aid enquirers to understand the text;
- present to the responsible international/European committee any enquiries on the interpretation, or proposals for change, and keep the UK interests informed;
- monitor related international and European developments and promulgate them in the UK.

A list of organizations represented on this committee can be obtained on request to its secretary.

Cross-references

The British Standards which implement international or European publications referred to in this document may be found in the *BSI Catalogue* under the section entitled “International Standards Correspondence Index”, or by using the “Search” facility of the *BSI Electronic Catalogue* or of British Standards Online.

This publication does not purport to include all the necessary provisions of a contract. Users are responsible for its correct application.

Compliance with a British Standard does not of itself confer immunity from legal obligations.

Summary of pages

This document comprises a front cover, an inside front cover, the EN title page, pages 2 to 8, an inside back cover and a back cover.

The BSI copyright notice displayed in this document indicates when the document was last issued.

Amendments issued since publication

Amd. No.	Date	Comments

This British Standard, was published under the authority of the Standards Policy and Strategy Committee on 22 December 2003

© BSI 22 December 2003

ISBN 0 580 43132 0

ICS 71.100.30

English version

Explosives for civil uses - Propellants and rocket propellants - Part 4: Determination of burning rate under ambient conditions

Explosifs à usage civil - Poudres propulsives et proergols
pour fusées - Partie 4: Détermination de la vitesse de
combustion dans les conditions ambiantes

Explosivstoffe für zivile Zwecke - Treibladungspulver und
Raketentreibstoffe - Teil 4: Bestimmung der
Brenngeschwindigkeit bei Umgebungsbedingungen

This European Standard was approved by CEN on 1 October 2003.

CEN members are bound to comply with the CEN/CENELEC Internal Regulations which stipulate the conditions for giving this European Standard the status of a national standard without any alteration. Up-to-date lists and bibliographical references concerning such national standards may be obtained on application to the Management Centre or to any CEN member.

This European Standard exists in three official versions (English, French, German). A version in any other language made by translation under the responsibility of a CEN member into its own language and notified to the Management Centre has the same status as the official versions.

CEN members are the national standards bodies of Austria, Belgium, Czech Republic, Denmark, Finland, France, Germany, Greece, Hungary, Iceland, Ireland, Italy, Luxembourg, Malta, Netherlands, Norway, Portugal, Slovakia, Spain, Sweden, Switzerland and United Kingdom.



EUROPEAN COMMITTEE FOR STANDARDIZATION
COMITÉ EUROPÉEN DE NORMALISATION
EUROPÄISCHES KOMITEE FÜR NORMUNG

Management Centre: rue de Stassart, 36 B-1050 Brussels

Contents

page

Foreword.....	3
1 Scope	3
2 Normative references	3
3 Terms and definitions.....	4
4 Principle	4
5 Apparatus	4
6 Preparation of test sample.....	5
7 Procedure	5
8 Expression of results	6
9 Test report	6
Annex A (informative) Range of applicability of the test method.....	7
Annex ZA (informative) Clauses of this European Standard addressing essential requirements or other provisions of EU Directives.	8

Foreword

This document EN 13938-4:2003 has been prepared by Technical Committee CEN /TC 321, "Explosives for civil uses", the secretariat of which is held by AENOR.

This European Standard shall be given the status of a national standard, either by publication of an identical text or by endorsement, at the latest by June 2004, and conflicting national standards shall be withdrawn at the latest by June 2004.

This document has been prepared under a mandate given to CEN by the European Commission and the European Free Trade Association, and supports essential requirements of EU Directive(s).

For relationship with EU Directive(s), see informative annex ZA, which is an integral part of this document.

This European Standard is one of a series of standards with the generic title "*Explosives for civil uses – Propellants and rocket propellants*". The other parts of this series are listed below:

- prEN 13938-1 Part 1: Requirements.
- prEN 13938-2 Part 2: Determination of resistance to electrostatic energy.
- EN 13938-3 Part 3: Determination of deflagration to detonation transition.
- prEN 13938-5 Part 5: Solid rocket propellants. Determination of voids and fissures.
- prEN 13938-6 Part 6: Solid rocket propellants. Guide for the determination of integrity of inhibitor coatings.
- prEN 13938-7 Part 7: Determination of the properties of black powder.

Annex A is informative.

According to the CEN/CENELEC Internal Regulations, the national standards organizations of the following countries are bound to implement this European Standard : Austria, Belgium, Czech Republic, Denmark, Finland, France, Germany, Greece, Hungary, Iceland, Ireland, Italy, Luxembourg, Malta, Netherlands, Norway, Portugal, Slovakia, Spain, Sweden, Switzerland and the United Kingdom.

1 Scope

This European Standard specifies a method for the determination of burning rate under ambient conditions for propellants and black powder.

It is applicable to propellants and black powder in their original form up to a grain size of 8 mm.

2 Normative references

This European Standard incorporates by dated or undated reference, provisions from other publications. These normative references are cited at the appropriate places in the text, and the publications are listed hereafter. For dated references, subsequent amendments to or revisions of any of these publications apply to this European Standard only when incorporated in it by amendment or revision. For undated references the latest edition of the publication referred to applies (including amendments).

EN 13938-4:2003 (E)

EN ISO/IEC 17025; *General requirements for the competence of testing and calibration laboratories (ISO/IEC 17025:1999)*.

EN 13857-1; *Explosives for civil uses - Part 1: Terminology*.

3 Terms and definitions

For the purposes of this European Standard, the terms and definitions given in EN 13857-1 and the following apply.

3.1

burning rate

velocity at which the flame propagates through the sample along the trough

4 Principle

The test sample is loaded into a trough and the sample is ignited at one end by means of a hot wire. The time of flame propagation through the sample along the trough is measured and the burning rate is calculated.

5 Apparatus

5.1 Trough, (see Figure 1), consisting of a half cylinder (2 000 ± 1) mm long with a diameter of (20,0 ± 0,8) mm, hollowed out from a stainless steel block. The block is marked at 2 positions, A and B, at distances of (400 ± 1) mm and (1 900 ± 1) mm from the end where the ignition is to take place, respectively. A 2 mm thick stainless steel plate is welded to each end of the trough to close off the ends.

The trough shall be horizontal when set on its support.

5.2 Hot wire, as ignition device, consisting of a Ni/Cr wire, diameter (0,40 ± 0,05) mm, length (15 ± 1) mm, heated by a current of 4 A.

5.3 Timing device, consisting of a manual stopwatch with a scale division of 0,1 s or a recording chronograph activated by suitable detectors located at marks A and B. Black powder shall be tested using a recording chronograph.

Dimensions in millimetres

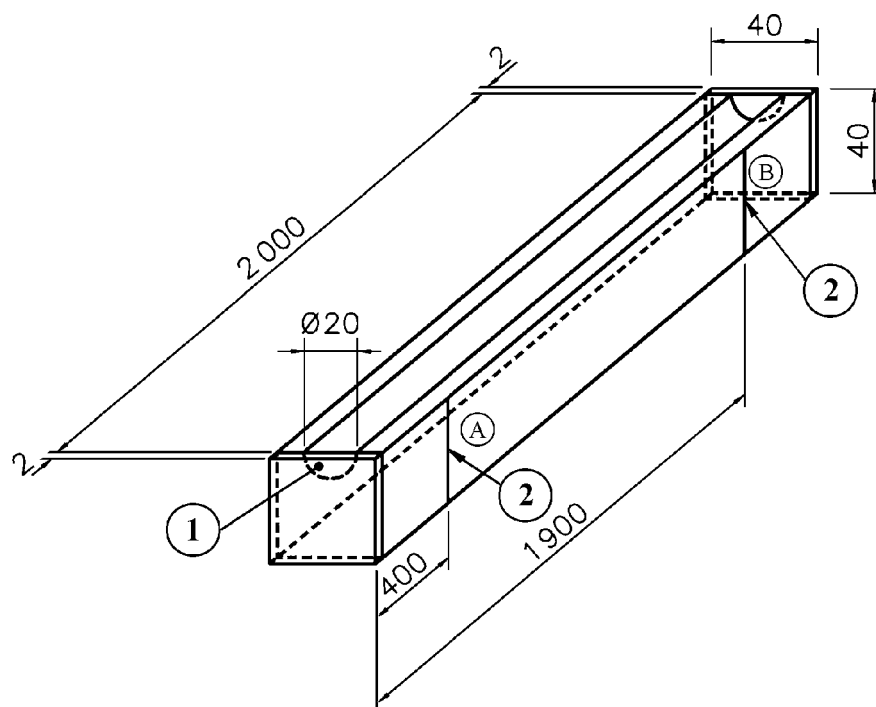
**Key**

1 Hot wire

2 Engraved marks

A First mark

B Second mark

Tolerance for all dimensions is 1 mm, except 0,8 mm for the diameter of the trough.

Figure 1 – Stainless steel trough**6 Preparation of test sample**

Condition the test sample by storing at $(20 \pm 5) ^\circ\text{C}$ and $(60 \pm 10) \%$ relative humidity for at least 24 h immediately prior the test.

7 Procedure

Carry out two determinations, using separate test portions taken from the test sample.

Conduct the test under ambient conditions of temperature and humidity.

Ensure that the trough is dry and clean and condition it at $(20 \pm 10) ^\circ\text{C}$.

Pour the test sample into the trough so as to fill it flush with the top edge, without packing down the test sample.

Level the surface by moving a blade across it and record the mass of the test portion.

The time between filling the trough and ignition shall not exceed 15 min.

Connect the hot wire to the electrical circuit.

Maintain the current until the sample ignites (maximum time 60 s).

Record the following:

- t_b time of flame propagation from mark A (400 mm) to mark B (1900 mm);
- t_f time from mark A to extinction, in case of partial propagation of the sample;
- d_f distance travelled by the flame in case of partial propagation of the sample.

NOTE This distance should be determined after disconnection of the hot wire and the cooling of the trough.

8 Expression of results

The burning rate of the sample under test shall be determined by means of the following equation:

$$V = \frac{1\ 500}{t_b}$$

Where

- V is the burning rate, expressed in millimetres per second (mm/s);
1 500 is the distance between the marks expressed millimetres (mm); and
 t_b is the time of propagation between the marks, expressed in seconds(s)

9 Test report

The test report shall conform to EN ISO/IEC 17025. In addition the following information shall be given:

- a) a reference to this standard;
- b) the complete identification of the sample, including its mass and grain size distribution;
- c) the results of all tests in form of:
 - time, t_b (s) and burning rate, V (mm/s)or, in case of partial propagation:
 - time, t_f (s) and distance, d_f (mm)
- d) the mean value of the burning rate obtained from the two tests (mm/s)

Annex A (informative)

Range of applicability of the test method

Range of applicability of the test method: - 30 °C to + 80 °C.

Annex ZA
(informative)

Clauses of this European Standard addressing essential requirements or other provisions of EU Directives.

This European standard has been prepared under a mandate given to CEN by the European Commission and the European Free Trade Association and supports essential requirements of EU Directive 93/15/EEC.

WARNING : Other requirements and other EU Directives may be applicable to the product(s) falling within the scope of this standard.

The clauses of this standard are likely to support requirements I.2 and II.1(a) of Directive 93/15/EEC.

Compliance with this standard provides one means of conforming with the specific essential requirements of the Directive concerned and associated EFTA regulations.

BSI — British Standards Institution

BSI is the independent national body responsible for preparing British Standards. It presents the UK view on standards in Europe and at the international level. It is incorporated by Royal Charter.

Revisions

British Standards are updated by amendment or revision. Users of British Standards should make sure that they possess the latest amendments or editions.

It is the constant aim of BSI to improve the quality of our products and services. We would be grateful if anyone finding an inaccuracy or ambiguity while using this British Standard would inform the Secretary of the technical committee responsible, the identity of which can be found on the inside front cover.
Tel: +44 (0)20 8996 9000. Fax: +44 (0)20 8996 7400.

BSI offers members an individual updating service called PLUS which ensures that subscribers automatically receive the latest editions of standards.

Buying standards

Orders for all BSI, international and foreign standards publications should be addressed to Customer Services. Tel: +44 (0)20 8996 9001.
Fax: +44 (0)20 8996 7001. Email: orders@bsi-global.com. Standards are also available from the BSI website at <http://www.bsi-global.com>.

In response to orders for international standards, it is BSI policy to supply the BSI implementation of those that have been published as British Standards, unless otherwise requested.

Information on standards

BSI provides a wide range of information on national, European and international standards through its Library and its Technical Help to Exporters Service. Various BSI electronic information services are also available which give details on all its products and services. Contact the Information Centre.
Tel: +44 (0)20 8996 7111. Fax: +44 (0)20 8996 7048. Email: info@bsi-global.com.

Subscribing members of BSI are kept up to date with standards developments and receive substantial discounts on the purchase price of standards. For details of these and other benefits contact Membership Administration.
Tel: +44 (0)20 8996 7002. Fax: +44 (0)20 8996 7001.
Email: membership@bsi-global.com.

Information regarding online access to British Standards via British Standards Online can be found at <http://www.bsi-global.com/bsonline>.

Further information about BSI is available on the BSI website at <http://www.bsi-global.com>.

Copyright

Copyright subsists in all BSI publications. BSI also holds the copyright, in the UK, of the publications of the international standardization bodies. Except as permitted under the Copyright, Designs and Patents Act 1988 no extract may be reproduced, stored in a retrieval system or transmitted in any form or by any means – electronic, photocopying, recording or otherwise – without prior written permission from BSI.

This does not preclude the free use, in the course of implementing the standard, of necessary details such as symbols, and size, type or grade designations. If these details are to be used for any other purpose than implementation then the prior written permission of BSI must be obtained.

Details and advice can be obtained from the Copyright & Licensing Manager.
Tel: +44 (0)20 8996 7070. Fax: +44 (0)20 8996 7553.
Email: copyright@bsi-global.com.