

# Railway applications — Measuring of new and modified freight wagons —

## Part 6: Multiple and articulated freight wagons

The European Standard EN 13775-6:2004 has the status of a  
British Standard

ICS 45.060.20

## National foreword

This British Standard is the official English language version of EN 13775-6:2004.

The UK participation in its preparation was entrusted by Technical Committee RAE/1, Railway applications, to Subcommittee RAE/1/-/9, Wagons (tank/freight), which has the responsibility to:

- aid enquirers to understand the text;
- present to the responsible international/European committee any enquiries on the interpretation, or proposals for change, and keep the UK interests informed;
- monitor related international and European developments and promulgate them in the UK.

A list of organizations represented on this subcommittee can be obtained on request to its secretary.

### Cross-references

The British Standards which implement international or European publications referred to in this document may be found in the *BSI Catalogue* under the section entitled “International Standards Correspondence Index”, or by using the “Search” facility of the *BSI Electronic Catalogue* or of British Standards Online.

This publication does not purport to include all the necessary provisions of a contract. Users are responsible for its correct application.

**Compliance with a British Standard does not of itself confer immunity from legal obligations.**

### Summary of pages

This document comprises a front cover, an inside front cover, the EN title page, pages 2 to 14, an inside back cover and a back cover.

The BSI copyright notice displayed in this document indicates when the document was last issued.

### Amendments issued since publication

Amd. No.	Date	Comments

This British Standard was published under the authority of the Standards Policy and Strategy Committee on 10 August 2004

© BSI 10 August 2004

ISBN 0 580 44168 7

EUROPEAN STANDARD

EN 13775-6

NORME EUROPÉENNE

EUROPÄISCHE NORM

June 2004

ICS 45.060.20

English version

## Railway applications - Measuring of new and modified freight wagons - Part 6: Multiple and articulated freight wagons

Applications ferroviaires - Mesure des wagons lors de leur construction et lors de modifications - Partie 6: Wagons à attelage court

Bahnanwendungen - Vermessung von Güterwagen beim Neubau und bei Umbauten - Teil 6: Kurzgekuppelte Güterwagen

This European Standard was approved by CEN on 1 April 2004.

CEN members are bound to comply with the CEN/CENELEC Internal Regulations which stipulate the conditions for giving this European Standard the status of a national standard without any alteration. Up-to-date lists and bibliographical references concerning such national standards may be obtained on application to the Central Secretariat or to any CEN member.

This European Standard exists in three official versions (English, French, German). A version in any other language made by translation under the responsibility of a CEN member into its own language and notified to the Central Secretariat has the same status as the official versions.

CEN members are the national standards bodies of Austria, Belgium, Cyprus, Czech Republic, Denmark, Estonia, Finland, France, Germany, Greece, Hungary, Iceland, Ireland, Italy, Latvia, Lithuania, Luxembourg, Malta, Netherlands, Norway, Poland, Portugal, Slovakia, Slovenia, Spain, Sweden, Switzerland and United Kingdom.



EUROPEAN COMMITTEE FOR STANDARDIZATION  
COMITÉ EUROPÉEN DE NORMALISATION  
EUROPÄISCHES KOMITEE FÜR NORMUNG

Management Centre: rue de Stassart, 36 B-1050 Brussels

## Contents

Page

Foreword.....	3
Introduction.....	4
1 Scope.....	4
2 Normative references.....	4
3 Terms and definitions.....	4
4 Symbols and abbreviations.....	5
5 Requirements.....	6
5.1 General.....	6
5.2 Preconditions.....	6
5.3 Additional or deviating measuring processes for type 2.....	6
Annex A (normative) Control sheet.....	12
Annex B (informative) Terminology.....	13
Bibliography.....	14

## Foreword

This document EN 13775-6:2004 has been prepared by Technical Committee CEN/TC 256 "Railway applications", the secretariat of which is held by DIN.

This European Standard shall be given the status of a national standard, either by publication of an identical text or by endorsement, at the latest by December 2004, and conflicting national standards shall be withdrawn at the latest by December 2004

This European Standard EN 13775 "Railway applications – Measurement of new and modified freight wagons" comprises the following parts:

- Part 1: Measuring principles
- Part 2: Freight wagons with bogies
- Part 3: Freight wagons with 2 wheelsets
- Part 4: Bogies with 2 wheelsets
- Part 5: Bogies with 3 wheelsets
- Part 6: Multiple and articulated freight wagons

Annex A is normative, Annex B is informative.

According to the CEN/CENELEC Internal Regulations, the national standards organizations of the following countries are bound to implement this European Standard: Austria, Belgium, Cyprus, Czech Republic, Denmark, Estonia, Finland, France, Germany, Greece, Hungary, Iceland, Ireland, Italy, Latvia, Lithuania, Luxembourg, Malta, Netherlands, Norway, Poland, Portugal, Slovakia, Slovenia, Spain, Sweden, Switzerland and the United Kingdom.

## Introduction

It is normal practice in all European countries to carry out checks and measurements on the major components of new and modified freight wagons and bogies. In view of the importance of uniform criteria for international transport in all European countries, this European Standard has been prepared.

### 1 Scope

This European Standard specifies principles and requirements for measuring multiple and articulated freight wagons. This ensures that the measuring processes are applied in accordance with uniform criteria. It applies to new and modified multiple and articulated freight wagons.

Provisions going beyond the scope of these requirements are generally agreed between the contracting parties involved.

The measuring processes relate to multiple and articulated freight wagons with or without add-ons in their entirety or just part of them if the geometrical structure does not permit anything else. Where appropriate, other measuring processes not specified here are necessary and are specified in each individual case.

### 2 Normative references

This European Standard incorporates by dated or undated reference, provisions from other publications. These normative references are cited at the appropriate places in the text and the publications are listed hereafter. For dated references, subsequent amendments to or revisions of any of these publications apply to this European Standard only when incorporated in it by amendment or revision. For undated references the latest edition of the publication referred to applies (including amendments).

EN 13775-1:2003, *Railway applications — Measuring new and modified freight wagons — Part 1: Measuring principles.*

EN 13775-2, *Railway applications — Measurement of new and modified freight wagons — Part 2: Freight wagons with bogies*

EN 13775-3, *Railway applications — Measurement of new and modified freight wagons — Part 3: Freight wagons with 2 wheelsets*

EN 13775-4, *Railway applications — Measurement of new and modified freight wagons — Part 4: Bogie with 2 wheelsets*

### 3 Terms and definitions

For the purposes of this European Standard, the terms and definitions given in EN 13775-1:2003, in Table 1 of the relevant parts of this standard and the following apply:

#### 3.1 element

underframe/body with its own partial or complete running gear

NOTE An element cannot be used operationally.

### 3.2 wagon units

set up comprising several continuously coupled elements equipped at both ends with traction and impact devices that can be released during operation

NOTE The elements are coupled by means of special devices that cannot be uncoupled during operation and consist either of elements with 2 wheelsets or elements with bogies (tight coupled) [UIC 572:1990].

### 3.3 articulated wagon

elements coupled to each other by means of an articulation over the running gear (articulated coupled) and consisting of at least 3 wheelsets or 3 bogies

[UIC 572:1990]

### 3.4 construction form

form in which the ends of the articulated elements with their partial running gear differ for the transmission of the vertical forces

NOTE Articulated coupling ends of construction form 1 in the coupled state lie on the articulated coupling ends of construction form 2 (see Figure 1). There is no connection between specifying the construction form and the allocation of the form of the articulated coupling device transmitting the longitudinal forces. In the case of articulated wagons with more than 2 elements, rigid allocation of a specific construction form to one end of an element is not possible.

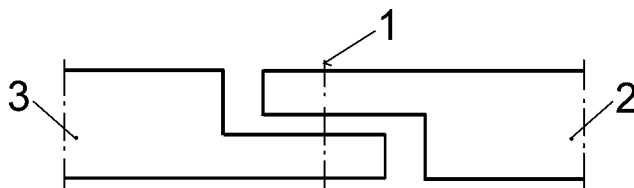

#### Key

- 1 Axis of rotation
- 2 Articulated coupling end of construction form 1
- 3 Articulated coupling end of construction form 2

Figure 1 — Position of the articulated coupling ends relative to each other

### 3.5 optional

process which is only carried out if specially agreed with the customer. The procedure is separately ordered.

## 4 Symbols and abbreviations

For the purposes of this European Standard, the following symbols and abbreviations apply.

- 1 Wagon end 1
- 2 Wagon end 2
- ← Traction/impact devices at end of unit/end of articulated wagon
- Tight coupling between elements

## EN 13775-6:2004 (E)

○ Wheelset

⊞ Bogie with 2 or more wheelsets

⋮ other elements

## 5 Requirements

### 5.1 General

The limit deviations apply to the finished product in each case.

Deviations from this European Standard are allowed as long as they do not assume proportions that represent an operating hazard. However, they shall be agreed with the contracting party involved and the inspection agency.

### 5.2 Preconditions

The precondition for carrying out the measuring processes as specified in this standard is that the measuring principles laid down in EN 13775-1 are adhered to.

Not all the measuring point dimension designations are listed in the figures in this standard. Unless otherwise indicated, the figures show the normal position.

Before measuring, the wagon unit or articulated wagon to be measured shall be assigned to one of the types shown in table 1. Measurement then takes place in accordance with the relevant parts of this standard, if necessary, using the additional or deviating measuring processes specified in this part of the standard.

**Table 1 — Wagon types and associated measuring processes**

Type	Diagram	Body	Running gear	Additional specifications
1		EN 13775-3	EN 13775-3	-
2		EN 13775-2	EN 13775-4	see 4.2
3		EN 13775-2	EN 13775-4	-

### 5.3 Additional or deviating measuring processes for type 2

A control sheet form for the results of the measuring processes is given in Annex A.



**Measuring process 1**

Length between headstock and the centre line of the articulation.

Shown in the backbone position.

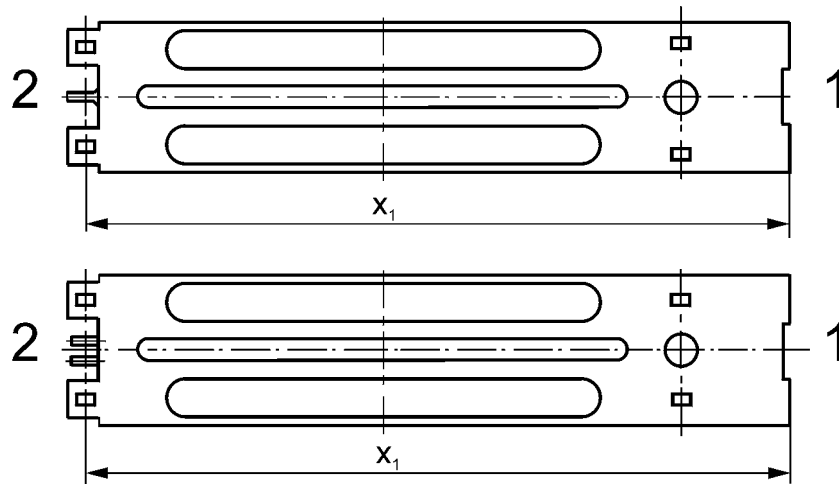

**Figure 2**

The total length  $x_1$  of the underframe between the headstock and the centre line of the articulation is measured in the element centre line (see Figure 2).

Limit deviations for  $x_1$ :  mm

**Measuring process 2**

Distance between the centres of the pivot or the parts replacing them.

Shown in the backbone position.

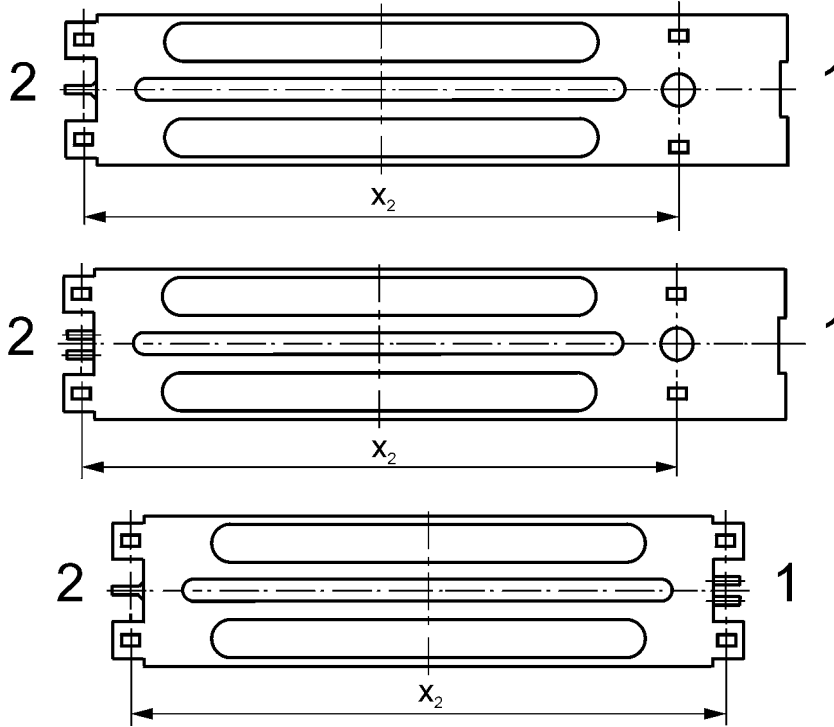

**Figure 3**

The distance  $x_2$  between the centres of the pivots or the centres of the parts replacing them is measured (see Figure 3).

Limit deviations for  $x_2$ :  $\pm 8$  mm

**Measuring process 3**

Distance between the centre of the friction plate supporting surfaces and the centre line of the wagon at the articulated coupling ends.

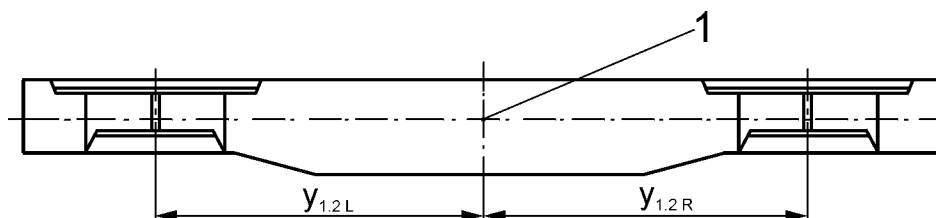
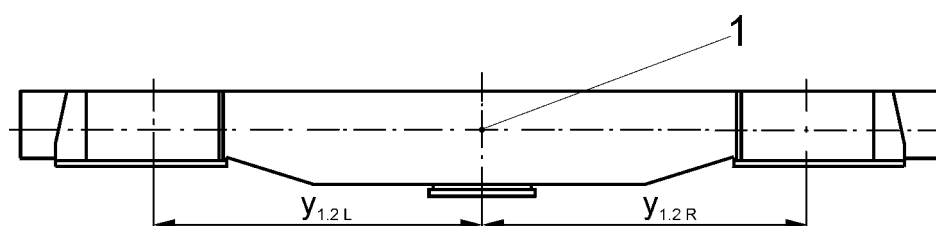
**Construction form 1****Construction form 2****Key**

1 Point of rotation

**Figure 4**

The distance  $y_1$  between the centre of the friction plate supporting surfaces and the centre line of the wagon is measured at measuring points 1R, 1L and 2R, 2L (see Figure 4).

Limit deviations for  $y_1$ :  $\pm 2$  mm

**Measuring process 4**

Distance between the centre of the point of rotation and the upper friction plate support surface at the articulated coupling end of construction form 1.

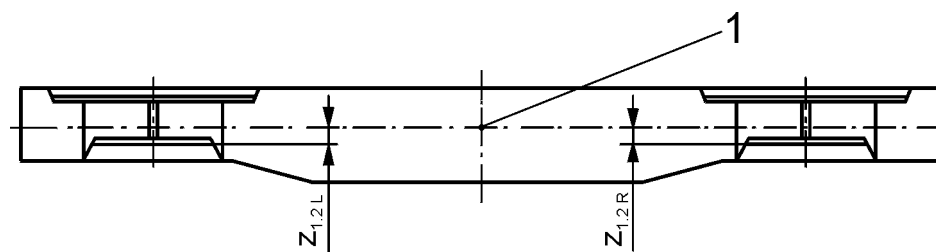
**Construction form 1****Key**

1 Point of rotation

**Figure 5**

**EN 13775-6:2004 (E)**

The distance  $z_1$  from the centre of the point of rotation at the articulated coupling end of construction form 1 is measured (see Figure 5) in each case in the centre of the lower friction plate support surface at measuring points 1R, 1L and 2R, 2L.

Limit deviations for  $z_1$ :  mm

**Measuring process 5**

Distance between the centre of the point of rotation and the upper friction plate support surface at the articulated coupling end of construction form 2.

**Construction form 2**

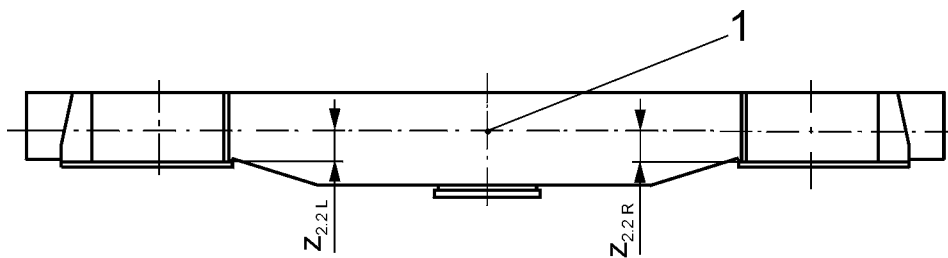

**Key**

1 Point of rotation

**Figure 6**

The distance  $z_2$  from the centre of the point of rotation at the articulated coupling end of construction form 2 is measured (see Figure 6), with the underframe in normal use, in each case in the centre of the lower friction support surface at measuring points 1R, 1L and 2R, 2L.

Limit deviations for  $z_2$ :  $\begin{matrix} +2 \\ -1 \end{matrix}$  mm

**Measuring process 6 – optional**

Distance between the centre of the lower friction plate support surface and the bottom edge of the underframe bolster at the articulated coupling end of construction form 2.

**Construction form 2**

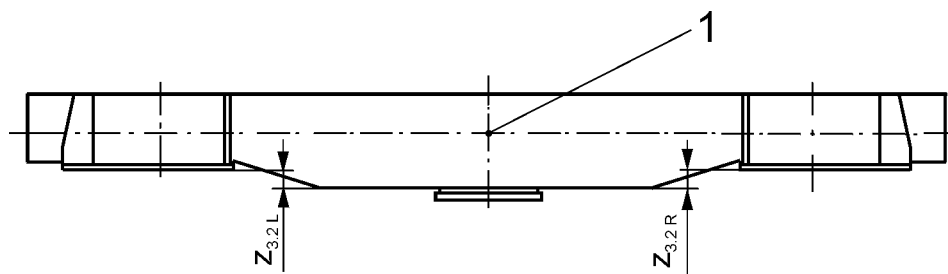

**Key**

1 Point of rotation

**Figure 7**

The distance  $z_3$  from the centre of the lower friction plate support surface to the bottom edge of the underframe bolster is measured at the articulated coupling end of construction form 2 (see Figure 7) with the underframe in normal use in each case in the centre of the lower friction plate support surface at measuring points 1L, 1R and 2L, 2R.

Limit deviations for  $z_3$ :  mm

**Measuring process 7**

Distance between the friction plates.

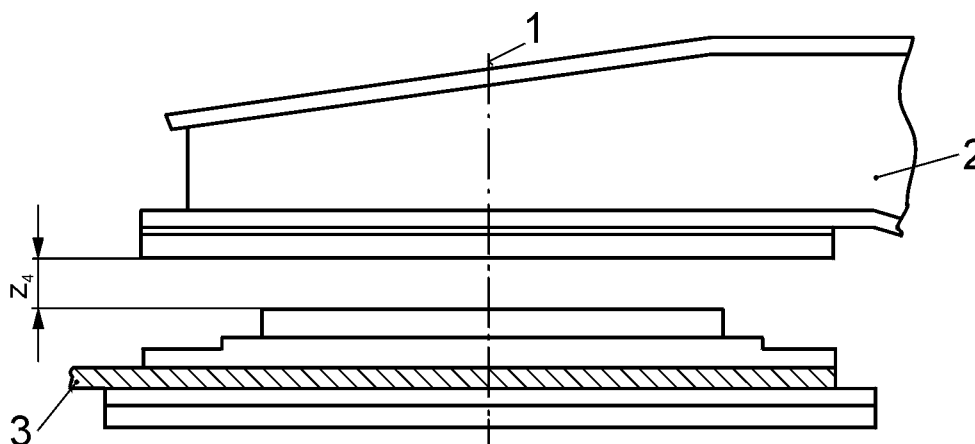

**Key**

- 1 Axis of rotation
- 2 Articulated coupling end of construction form 1
- 3 Articulated coupling end of construction form 2

**Figure 8**

The distance  $z_4$  between the articulated coupling end friction plates at each end at each side of the coupled articulated wagon is measured at the measuring points 1R, 1L and 2R, 2L (see Figure 8).

Limit deviations for  $z_4$ :  mm

## Annex A (normative)

### Control sheet

**Control sheet form** Annex A contains a control sheet form with the individual measuring processes. The structures of the control sheet are based on practical experience. This form shall be used in principle for documenting the measured results. In Table A.1 "Control sheet form", dotted lines have been provided in the "Measuring point/nominal dimension" column for recording the nominal dimensions of the drawings. In the "Actual limit deviations at the designated measuring points" column, there are spaces for recording the limit deviations or tolerances actually established. This makes statistical assessment possible.

**Table A.1 — Control sheet**

Measuring process		Dimensions in mm		Actual limit deviations or tolerances at the designated measuring points						Remark	
		Measuring point nominal dimension	Limit deviation or tolerance	1	2	3	4	5	6		
1	Length between headstock and the centre line of the articulation	$x_1$	+12 -0	R							
				L							
2	Distance between the centres of the pivot or the parts replacing them	$x_2$ .....	± 8	R							
				L							
3	Distance between the centre of the friction plate supporting surfaces and the centre line of the wagon at the articulated coupling ends	Construction form 1 : $y_1$ .....	± 2	R							
				L							
		Construction form 2 : $y_1$ .....	± 2	R							
				L							
4	Distance between the centre of the point of rotation and the upper friction plate support surface at the articulated coupling end of construction form	$z_1$ .....	+1 -4	R							
				L							
5	Distance between the centre of the point of rotation and the upper friction plate support surface at the articulated coupling end of construction form 2	$z_2$ .....	+4 -1	R							
				L							
6	Distance between the centre of the lower friction plate support surface and the bottom edge of the underframe bolster at the articulated coupling end of construction form 2	$z_3$ .....	+2 -1	R							optional
				L							
7	Distance between the friction plates	$z_4$ .....	+1 -2	R							
				L							
Company		Purchaser:		Underframe No.:			Bogie No.:				
				Date:	Name:	Date:	Name:				
Order No.:		Acceptance:									
Sheet No.:		Drawing No.:		Approval:							

## Annex B (informative)

### Terminology

English	French	German
Articulated <sup>a</sup>	articulé	kurzgekuppelt
Articulated wagon	wagon articulé	Gelenkwagen
Axis of rotation	axe de rotation	Drehachse
Body	structure de wagon	Wagenkasten
Construction form	forme de construction	Bauform
Element	élément	Element
Friction plate	lisoir de caisse	Gleitplatte (am Wagen)
Lower friction plate	lisoir de caisse inférieur	untere Gleitplatte
Normal use	situation d'exploitation	Gebrauchslage
Point of rotation	point de rotation	Drehpunkt
Running gear	organe de roulement	Laufwerk
Tight coupled <sup>a</sup>	attelage permanent	kurzgekuppelt
Upper friction plate	lisoir de caisse supérieur	obere Gleitplatte
Wagon unit	unité wagon	Wageneinheit
<sup>a</sup> see also clause 3 Terms and definitions		

## Bibliography

- [1] prEN 12777:1997, *Logistics — Structure, basic terms and definitions in logistics.*
- [2] EN 13775-5, *Railway applications — Measurement of new and modified freight wagons — Part 5: Bogies with 3 wheelsets.*
- [3] UIC 572:1990, *Wagons composed of permanently coupled units (multiple wagons) and articulated wagons — Standardization/Note: Including 4th amendment up to 1996-07-01*





---

---

# BSI — British Standards Institution

BSI is the independent national body responsible for preparing British Standards. It presents the UK view on standards in Europe and at the international level. It is incorporated by Royal Charter.

## Revisions

British Standards are updated by amendment or revision. Users of British Standards should make sure that they possess the latest amendments or editions.

It is the constant aim of BSI to improve the quality of our products and services. We would be grateful if anyone finding an inaccuracy or ambiguity while using this British Standard would inform the Secretary of the technical committee responsible, the identity of which can be found on the inside front cover.  
Tel: +44 (0)20 8996 9000. Fax: +44 (0)20 8996 7400.

BSI offers members an individual updating service called PLUS which ensures that subscribers automatically receive the latest editions of standards.

## Buying standards

Orders for all BSI, international and foreign standards publications should be addressed to Customer Services. Tel: +44 (0)20 8996 9001.  
Fax: +44 (0)20 8996 7001. Email: [orders@bsi-global.com](mailto:orders@bsi-global.com). Standards are also available from the BSI website at <http://www.bsi-global.com>.

In response to orders for international standards, it is BSI policy to supply the BSI implementation of those that have been published as British Standards, unless otherwise requested.

## Information on standards

BSI provides a wide range of information on national, European and international standards through its Library and its Technical Help to Exporters Service. Various BSI electronic information services are also available which give details on all its products and services. Contact the Information Centre.  
Tel: +44 (0)20 8996 7111. Fax: +44 (0)20 8996 7048. Email: [info@bsi-global.com](mailto:info@bsi-global.com).

Subscribing members of BSI are kept up to date with standards developments and receive substantial discounts on the purchase price of standards. For details of these and other benefits contact Membership Administration.  
Tel: +44 (0)20 8996 7002. Fax: +44 (0)20 8996 7001.  
Email: [membership@bsi-global.com](mailto:membership@bsi-global.com).

Information regarding online access to British Standards via British Standards Online can be found at <http://www.bsi-global.com/bsonline>.

Further information about BSI is available on the BSI website at <http://www.bsi-global.com>.

## Copyright

Copyright subsists in all BSI publications. BSI also holds the copyright, in the UK, of the publications of the international standardization bodies. Except as permitted under the Copyright, Designs and Patents Act 1988 no extract may be reproduced, stored in a retrieval system or transmitted in any form or by any means – electronic, photocopying, recording or otherwise – without prior written permission from BSI.

This does not preclude the free use, in the course of implementing the standard, of necessary details such as symbols, and size, type or grade designations. If these details are to be used for any other purpose than implementation then the prior written permission of BSI must be obtained.

Details and advice can be obtained from the Copyright & Licensing Manager.  
Tel: +44 (0)20 8996 7070. Fax: +44 (0)20 8996 7553.  
Email: [copyright@bsi-global.com](mailto:copyright@bsi-global.com).