

**Thermoplastic multi-layer (non-vulcanized) hoses and hose assemblies for the transfer of liquid petroleum gas and liquefied natural gas — Specification**

ICS 23.040.70

## National foreword

This British Standard is the UK implementation of EN 13766:2010. It supersedes BS EN 13766:2003 which is withdrawn.

The UK participation in its preparation was entrusted to Technical Committee PRI/66, Rubber and plastics tubing, hoses and hose assemblies.

A list of organizations represented on this committee can be obtained on request to its secretary.

This publication does not purport to include all the necessary provisions of a contract. Users are responsible for its correct application.

**Compliance with a British Standard cannot confer immunity from legal obligations.**

This British Standard was published under the authority of the Standards Policy and Strategy Committee on 30 June 2010

© BSI 2010

ISBN 978 0 580 64332 3

### Amendments/corrigenda issued since publication

Date	Comments

EUROPEAN STANDARD

**EN 13766**

NORME EUROPÉENNE

EUROPÄISCHE NORM

June 2010

ICS 23.040.70

Supersedes EN 13766:2003

English Version

## Thermoplastic multi-layer (non-vulcanized) hoses and hose assemblies for the transfer of liquid petroleum gas and liquefied natural gas - Specification

Tuyaux et flexibles en thermoplastique multi couches (non vulcanisés) utilisés pour le dépotage de gaz pétrolier liquide et gaz naturel liquéfié - Spécification

Thermoplastische, mehrlagige (nicht vulkanisierte) Schläuche und Schlauchleitungen für die Förderung von Flüssiggas und verflüssigtem Erdgas - Spezifikation

This European Standard was approved by CEN on 5 May 2010.

CEN members are bound to comply with the CEN/CENELEC Internal Regulations which stipulate the conditions for giving this European Standard the status of a national standard without any alteration. Up-to-date lists and bibliographical references concerning such national standards may be obtained on application to the CEN Management Centre or to any CEN member.

This European Standard exists in three official versions (English, French, German). A version in any other language made by translation under the responsibility of a CEN member into its own language and notified to the CEN Management Centre has the same status as the official versions.

CEN members are the national standards bodies of Austria, Belgium, Bulgaria, Croatia, Cyprus, Czech Republic, Denmark, Estonia, Finland, France, Germany, Greece, Hungary, Iceland, Ireland, Italy, Latvia, Lithuania, Luxembourg, Malta, Netherlands, Norway, Poland, Portugal, Romania, Slovakia, Slovenia, Spain, Sweden, Switzerland and United Kingdom.



EUROPEAN COMMITTEE FOR STANDARDIZATION  
COMITÉ EUROPÉEN DE NORMALISATION  
EUROPÄISCHES KOMITEE FÜR NORMUNG

**Management Centre: Avenue Marnix 17, B-1000 Brussels**

## Contents

Page

Foreword.....	3
1 Scope .....	4
2 Normative references .....	4
3 Terms and definitions .....	5
4 Classification.....	5
5 Materials and construction .....	5
6 Dimensions.....	6
6.1 Internal diameters, with tolerances and minimum bend radii.....	6
6.2 Tolerance on length.....	7
7 Performance requirements of hoses and hose assemblies.....	7
7.1 Film and fabric .....	7
7.2 Hoses .....	7
7.3 End fittings .....	8
7.4 Hose assemblies.....	8
7.5 Electrical continuity.....	9
8 Test frequency .....	9
9 Type tests .....	9
10 Marking .....	10
10.1 Hose marking .....	10
10.2 Hose assembly marking.....	10
Annex A (normative) Crush recovery test .....	11
Annex B (normative) Method of test for thermal ageing.....	13
Annex C (normative) Method of test of fittings subjected to low temperatures.....	14
C.1 General.....	14
C.2 Specimen size .....	14
Annex D (normative) Sequence of hydrostatic tests.....	15
Annex E (normative) Method of test for fitting security.....	16
Annex F (normative) Method of test for leak tightness.....	18
Annex G (normative) Type and routine tests for hoses and hose assemblies .....	19
Annex H (informative) Batch tests for hoses and hose assemblies .....	20
Bibliography .....	21

## Foreword

This document (EN 13766:2010) has been prepared by Technical Committee CEN/TC 218 “Rubber and plastics hoses and hose assemblies”, the secretariat of which is held by BSI.

This European Standard shall be given the status of a national standard, either by publication of an identical text or by endorsement, at the latest by December 2010, and conflicting national standards shall be withdrawn at the latest by December 2010.

This document supersedes EN 13766:2003.

**Compared to the 2003 version, changes have been made to the following (sub)clauses, tables and annexes:**

- Scope: Reference to EN 1474-2 added;
- Table 1: Temperature has been changed to  $-196\text{ }^{\circ}\text{C}$ ;
- 7.1: Reference to new test standards added;
- Table 3: Change in length test refined;
- Table 4: Electrical resistance test refined;
- 7.5: Electrical Continuity text added;
- 10.1: Hose marking simplified;
- Annex E: text revised to incorporate cyclic testing to low temperatures;
- Annex G: Tests moved from hose to hose assemblies;
- Annex H: Tests moved from hose to hose assemblies.

This document has also been presented to ISO/TC 45/SC 1, for adoption as an ISO standard under the Vienna agreement.

According to the CEN/CENELEC Internal Regulations, the national standards organizations of the following countries are bound to implement this European Standard: Austria, Belgium, Bulgaria, Croatia, Cyprus, Czech Republic, Denmark, Estonia, Finland, France, Germany, Greece, Hungary, Iceland, Ireland, Italy, Latvia, Lithuania, Luxembourg, Malta, Netherlands, Norway, Poland, Portugal, Romania, Slovakia, Slovenia, Spain, Sweden, Switzerland and United Kingdom.

## 1 Scope

This European Standard specifies requirements for two types of thermoplastic multi-layer (non-vulcanized) transfer hoses and hose assemblies for carrying liquefied petroleum gas and liquefied natural gas. Each type is subdivided into two classes, one for onshore duties, and the other for offshore.

This European Standard is applicable for hose sizes from 25 mm to 250 mm, working pressures from 10,5 bar to 25 bar and operating temperatures from – 196 °C to + 45 °C.

NOTE Offshore LNG hose assemblies are also specified in EN 1474-2.

**WARNING — Persons using this European Standard should be familiar with normal laboratory practice.**

**This standard does not purport to address all the safety problems, if any, associated with its use. It is the responsibility of the user to establish appropriate health and safety practices and to ensure compliance with any national regulatory conditions.**

## 2 Normative references

The following referenced documents are indispensable for the application of this document. For dated references, only the edition cited applies. For undated references, the latest edition of the referenced document (including any amendments) applies.

EN 10045-1, *Metallic materials — Charpy impact test — Part 1: Test method*

EN 10088-3, *Stainless steels — Part 3: Technical delivery conditions for semi-finished products, bars, rods, wire, sections and bright products of corrosion resisting steels for general purposes*

EN ISO 527-1, *Plastics - Determination of tensile properties — Part 1: General principles (ISO 527-1:1993 including Corr 1:1994)*

EN ISO 1043-1, *Plastics — Symbols and abbreviated terms — Part 1: Basic polymers and their special characteristics (ISO 1043-1:2001)*

EN ISO 1402:2009, *Rubber and plastics hoses and hose assemblies — Hydrostatic testing (ISO 1402:2009)*

EN ISO 1746, *Rubber or plastics hoses and tubing — Bending tests (ISO 1746:1998, including technical corrigendum 1:1999)*

EN ISO 4671, *Rubber and plastics hose and hose assemblies — Methods of measurement of the dimensions of hoses and the lengths of hose assemblies (ISO 4671:2007)*

EN ISO 4672, *Rubber and plastics hoses — Sub-ambient temperature flexibility tests (ISO 4672:1997)*

EN ISO 7326, *Rubber and plastics hoses — Assessment of ozone resistance under static conditions (ISO 7326:2006)*

EN ISO 8031:2009, *Rubber and plastics hoses and hose assemblies — Determination of electrical resistance and conductivity (ISO 8031:2009)*

EN ISO 8330:2008, *Rubber and plastics hoses and hose assemblies — Vocabulary (ISO 8330:2007)*

EN ISO 13934-1, *Textiles — Tensile properties of fabrics — Part 1: Determination of maximum force and elongation at maximum force using the strip method (ISO 13934-1:1999)*

### 3 Terms and definitions

For the purposes of this document, the terms and definitions given in EN ISO 8330:2008 apply.

### 4 Classification

Hoses shall be classified according to their usage, working pressure and working temperature range as given in Table 1.

**Table 1 — Pressure and temperature range**

Pressure/temperature	Class A <sup>a</sup>	Class B <sup>b</sup>	Class A	Class B
	Type 1	Type 1	Type 2	Type 2
Maximum working pressure (bar)	25	20	13	10,5
Proof pressure (bar)	37,5	30	19,5	15,8
Minimum burst pressure (bar)	100	100	52	52,5
Working temperature range (°C)	- 50 ± 3 to + 45	- 50 ± 3 to + 45	- 196 ± 5 to + 45	- 196 ± 5 to + 45
NOTE 1 1 bar = 0,1 Mpa				
NOTE 2 Due to pressurisation during test and operations the temperature of the fluid could increase. The indicated temperatures are measured at atmospheric pressure;				
<sup>a</sup> Class A is for use onshore.				
<sup>b</sup> Class B is for use offshore.				

### 5 Materials and construction

Hoses shall be constructed as shown in Figure 1 and shall consist of the following:

#### a) Class A:

- 1) An internal wire helix of stainless steel conforming to EN 10088-3, numbers 1.4306, 1.4401, 1.4404 or 1.4436;
- 2) A multi-ply wall of layers of films and fabrics made of thermoplastics that in combination give the required properties specified in Table 1 and provide a complete seal;
- 3) An external wire helix of stainless steel conforming to EN 10088-3, numbers 1.4306, 1.4401, 1.4404 or 1.4436.

#### b) Class B:

- 1) An internal wire helix of stainless steel conforming to EN 10088-3, numbers 1.4401, 1.4404 or 1.4436;
- 2) A multi-ply wall of layers of films and fabrics made of thermoplastics that in combination give the required properties specified in Table 1 and provide a complete seal;
- 3) An external wire helix of stainless steel conforming to EN 10088-3, numbers 1.4401, 1.4404 or 1.4436.

NOTE By agreement between manufacturer and purchaser, the outer layer may have colour identification.

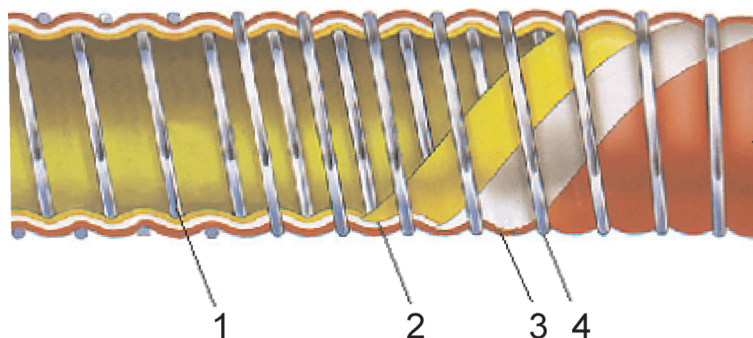

**Key**

- 1 internal wire
- 2 film
- 3 fabric
- 4 external wire

**Figure 1 — Section of a typical thermoplastic multilayer hose**

**6 Dimensions**

**6.1 Internal diameters, with tolerances and minimum bend radii**

When measured in accordance with EN ISO 4671, the values of the internal diameter of the hose shall conform to Table 2. When tested by the method described in EN ISO 1746 the value of the minimum bend radius shall be as given in Table 2. The hose shall show no sign of permanent deformation of the cross section i.e. kinking.

**Table 2 — Dimensions and minimum bend radius**

Dimensions in millimetres

Internal diameter	Tolerance	Minimum bend radius
25	± 1	150
32	± 1	175
38	± 1	175
40	± 1	200
50	± 1	200
65	± 2	200
75	± 2	250
80	± 2	250
100	± 2	500
150	± 2	660
200	± 3	910
250	± 3	2 500



## 6.2 Tolerance on length

When tested in accordance with EN ISO 4671 the tolerance on the measured length of delivered hose assemblies shall be  ${}^{+2}_{-1}$  %.

## 7 Performance requirements of hoses and hose assemblies

### 7.1 Film and fabric

When tested at the minimum temperature, Type 1:  $-50 \pm 3$  °C and Type 2:  $-196 \pm 5$  °C (and in accordance with EN ISO 13934-1 or equivalent for fabric testing and EN ISO 527-1 or equivalent for film testing ) samples of film and fabric shall have an elongation at break of not less than 10 %.

### 7.2 Hoses

When tested in accordance with the methods given in Table 3, the physical properties of the hoses shall conform to Table 3.

**Table 3 — Physical properties of hoses**

Property	Unit	Requirement	Method
Proof pressure	Bar	No leakage or other signs of damage at pressure given in Table 1	EN ISO 1402 with pressure increase not less than 1,7 bar/min
Change in length at proof pressure (max)	%	10	EN ISO 1402:2009, 8.2 initial length measured when the hose is pressurised to 0,7 bar
Twist at proof pressure (max)	°/m	10	EN ISO 1402:2009, 8.2 initial reading taken when hose is pressurised to 0,7 bar
Burst pressure	Bar	≥ Values in Table 1	EN ISO 1402
Bend	—	No leakage or visible damage when the hose is bent to radius given in Table 2 and subjected to the proof pressure.	EN ISO 1746
Crush recovery (max)	%	3	Annex A
Ozone resistance 72 h at 40 °C	—	No cracking observed at × 2 magnification	EN ISO 7326
Thermal ageing	—	No leakage at proof pressure given in Table 1	Annex B
Low temperature flexibility	—	Test at minimum temperature given in Table 1	EN ISO 4672

### 7.3 End fittings

End fittings and metallic ferrules shall be made from the following materials depending on the type of hose to be used in the assembly:

- Type 1 hose: LT (low temperature) grade carbon steel or stainless steel;
- Type 2 hose: austenitic stainless steel tested in accordance with Annex C.

For all types of end fittings, that part of the fitting that enters the hose and forms the means by which the fitting is connected to the hose shall be provided with scrolls or protrusions on the surface that correspond to the pitch of the internal helix wire of the hose.

### 7.4 Hose assemblies

Hose assemblies shall be fitted with end fittings as described in 7.3.

End fittings shall be attached to the hose by one of the following methods:

- a) by the use of a seal and a metal ferrule which is swaged or crimped;
- b) by the use of a thermoset resin e.g. epoxy and a metal ferrule which is swaged or crimped.

NOTE Hoses should be assembled by the hose manufacturer.

When tested by the methods given in Table 4, hose assembly shall conform to Table 4.

When assembled to a hose there shall be electrical continuity between the end fitting and the internal and external wires.

**Table 4 — Physical properties of hose assemblies**

Property	Unit	Requirements	Method(s)
Proof pressure	Bar	No leakage or other signs of weakness at pressure given in Table 1	EN ISO 1402 with a pressure increase not less than 1,7 bar/min
Bend	—	No leakage or visible damage when the hose is bent to the radius given in Table 2 and is subjected to the proof pressure	EN ISO 1746
Series of hydrostatic tests	Bar % °/m	≥ burst pressure given in Table 1 Change in length as in Table 3 Twist as given in Table 3	Annex D
Security of end fitting	Bar	No leakage at proof pressure given in Table 1	Annex E and EN ISO 1402
Electrical resistance between end fittings	Ω	No reduction of electrical resistance between end fittings  ≤ 2,5 ohm/m for sizes less than 50 mm.  ≤ 1,0 ohm/m for the 50 mm size and above sizes	EN ISO 8031:2009, 4.8
Leak tightness	—	No leakage of air when subjected to 3,5 bar for 5 min	Annex F

## 7.5 Electrical continuity

There shall be electrical continuity between both internal and external wires and the end fittings. Manufacturers shall demonstrate by testing or calculation that the measured overall electrical resistance of the hose assembly incorporates both inner and outer wires being part of the circuit.

## 8 Test frequency

Routine tests shall be carried out on each hose assembly and in accordance with Annex G.

It is recommended that batch tests are carried out for every 10 000 m of manufacture or once a year, varying the sizes and types and in accordance with Annex H.

## 9 Type tests

Type tests shall be carried out to confirm that the hose assembly design, materials and method of manufacture meets the requirements of this standard.

Type tests shall be carried out on at least three sizes of hose including the smallest and largest for each type in the manufacturer's range.

Type tests shall be repeated, and the results recorded, at least every five years or whenever a change in the materials and/or method of manufacture is made.

## **10 Marking**

### **10.1 Hose marking**

Each hose assembly shall be permanently marked at an interval of not greater than 1 m with lettering of a minimum height of 10 mm with at least the following information:

- a) Manufacturer's name or identification mark, e.g. MAN Ltd;
- b) Number and year of this European Standard, i.e. EN 13766:2010;
- c) Hose identification (class and type) e.g. Class B — Type 1;
- d) Internal diameter, e.g. 40 mm;
- e) Maximum working pressure;
- f) Working temperature range;
- g) Material of the hose inner liquid barrier layer as referenced in EN ISO 1043-1 e.g. PP (polypropylene);
- h) Quarter and year of hose manufacture.

EXAMPLE:

MAN Ltd — EN 13766:2010 — Class B — Type 1 — 40 — 20 bar — - 50 +45 °C — PP — 4Q/10

### **10.2 Hose assembly marking**

Each hose assembly shall be permanently marked on the ferrule at one end with all the information given in 10.1 and in addition:

- a) Hose assembly serial number;
- b) Last test date of the hose assembly;
- c) Quarter and year of hose assembly manufacture, e.g. 4Q/10.

## Annex A (normative)

### Crush recovery test

The following test shall be conducted at room temperature ( $23 \pm 3^\circ\text{C}$ ).

Place a test piece of length  $\geq 350$  mm on a rigid, flat base plate so that it is not taut.

Place a 100 mm square 10 mm thick test plate centrally on the test piece. Measure the distance between two plates ( $d_1$ ) (see Figure A.1).

Apply test force,  $F$ , (see Table A.1) to the test plate for a period of 3 min.

The hose outside diameter can be reduced  $\leq 15\%$  at this stage.

Remove the test force and re-measure the distance between the two plates ( $d_2$ ) after 5 min.

The reduction in thickness,  $d_r$ , is expressed as a percentage by the equation:

$$d_r = \frac{d_1 - d_2}{d_1} \times 100$$

where

$d_1$  is the original thickness in millimetres (mm);

$d_2$  is the final thickness in millimetres (mm).

**Table A.1 — Test force**

Nominal bore	Test force, $F$ N
$\leq 50$	1 500
$> 50$	2 000

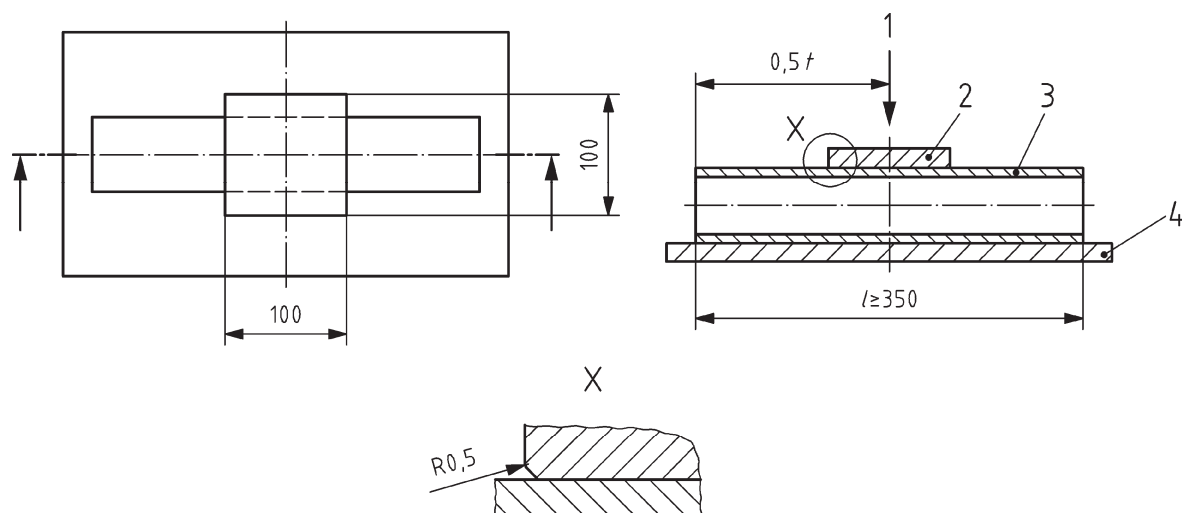

**Key**

- 1 test force,  $F$
- 2 test plate
- 3 test piece
- 4 baseplate

**Figure A.1 — Arrangement for crush recovery test**

## **Annex B** (normative)

### **Method of test for thermal ageing**

Fill a hose assembly with water, excluding all air, and cap both ends.

Heat the test piece at the maximum working temperature appropriate to the type as given in Table 1 for 200 h.

Keeping the hose assembly at the maximum working temperature, raise the internal pressure to 1,5 times the maximum working pressure (as given in Table 1) for a period of 15 min.

## Annex C (normative)

### Method of test of fittings subjected to low temperatures

#### C.1 General

Where impact tests are required, Charpy V-notch tests shall be performed in accordance with EN 10045-1. Tests shall be conducted at the minimum operating temperature. The impact energy requirements shall be met in the base material, heat affected zone and weld metal if present.

#### C.2 Specimen size

Where the component is greater than 10 mm thick the specimen size shall be 10 mm × 10 mm and the impact energy shall be 40 J. Where the base material is less than 10 mm thick the energy requirements shall be as given in Table C.1. Where test pieces at least 5 mm wide cannot be obtained the material shall not be subjected to impact testing.

**Table C.1 — Impact requirements for sub-sized Charpy V-notched specimen if base material is less than 10 mm thick**

Specimen geometry (mm)	10 × 10	10 × 7,5	10 × 5
Minimum impact energy (J)	40	32	28



## Annex D (normative)

### Sequence of hydrostatic tests

The following sequence of tests shall be carried out on a hose assembly for type testing:

- a) measure the electrical resistance between end fittings in accordance with EN ISO 8031;
- b) maintain the hose at a pressure of 0,7 bar for the time given in EN ISO 1402:2009, 8.2;
- c) mark and measure the hose in accordance with EN ISO 1402:2009, 8.2;
- d) raise the pressure at a rate of at least 1,7 bar/min to the proof pressure appropriate to the type of the hose, see Table 1;
- e) re-measure the marks in c) and determine the increase/decrease in length;
- f) release the pressure, bend the hose to the appropriate radius given in Table 2, and repeat d) above;
- g) release the bend in the hose and increase the pressure over a period of at least 15 min to the appropriate minimum burst pressure for the type of hose and hold for a further 15 min; check the electrical resistance between fittings;
- h) release the pressure, cool the assembly to  $-50 \pm 3$  °C for type 1 hoses or  $-196 \pm 5$  °C for type 2 hoses and reapply the pressure at a rate not less than 1,7 bar/min until the hose assembly bursts; record the burst pressure value.

## Annex E (normative)

### Method of test for fitting security

The following test procedure shall be used for type 1 and type 2 hose assemblies as given in Table 1, provided that the test equipment is suitable for the appropriate specified type of test liquid. For type 1 hoses use refrigerated methylated spirit at  $-50\text{ °C} \pm 5\text{ °C}$  and for type 2 hoses use liquid nitrogen at  $-196\text{ °C}$ :

- a) use an assembly having a length of at least 4 diameters free hose;
- b) connect hose to test equipment designed for one of the above mentioned test liquids;
- c) thermocouples can be used on the inside of the hose for a clear indication of the liquid level;
- d) lay the hose in horizontal position (Figure E.1);
- e) make sure that the hose can elongate during pressurizing, by using wheels or other transport equipment;
- f) measure the electrical resistance between end fittings in accordance with EN ISO 8031;
- g) start to fill the hose with one of the above mentioned test liquids;
- h) when hose is filled completely with the appropriate test liquid given above, start to pressurize the hose to the maximum working pressure given in Table 1;
- i) keep the hose on the maximum working pressure, given in Table 1, for 30 min;
- j) empty the hose and heat up the hose by using a hot air blower;
- k) test the hose on leakage with nitrogen gas at the proof pressure given in Table 1; any leakage can be detected by checking on pressure drop;
- l) re-measure the electrical resistance between the end fittings in accordance with EN ISO 8031 and note any axial movement of either end fitting relative to the hose; compare results with measurement mentioned under f;
- m) minimum of 20 cycles is required; the next cycle can be started when the hose is back at ambient temperature.

After completing 20 cycles test for leakage at ambient temperature using water at the proof pressure as per Table 1 and in accordance with EN ISO 1402, a burst test will be required, minimum burst pressure as per Table 1 in accordance with EN ISO 1402. The burst test shall be done with water at ambient temperature.

During testing no leakage is allowed.

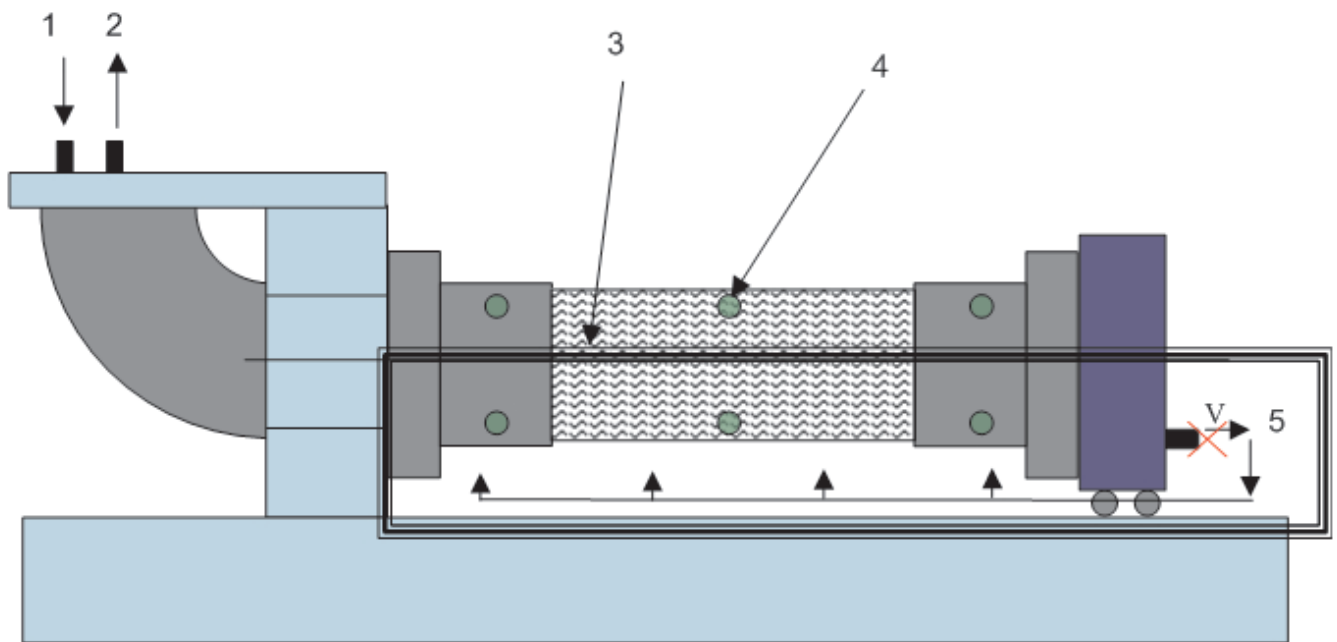

#### Key

- 1= test liquid inlet (connected to test pump)
- 2= vapour outlet (connected to test pump)
- 3= insulated trough
- 4= thermocouples (6 in total, indicated by ● )
- 5= test liquid / vapour outlet and valve (indicated by × )
- V= vapour flow, indicated by arrows

Figure E.1 — Arrangement for fitting security test

## **Annex F** (normative)

### **Method of test for leak tightness**

Apply a pneumatic pressure of 3,5 bar to the hose assembly and either submerge the assembly in a water bath or apply a solution of soap and water over the entire surface.

Ignore any immediate evidence of bubbling.

Hold the pressure for 5 min and note any continuous evidence of bubbling.

**Annex G**  
(normative)

**Type and routine tests for hoses and hose assemblies**

**Table G.1 — Type and routine tests for hoses and hose assemblies**

Property	Type tests	Routine tests
<b>Hose film &amp; fabric</b>		
Elongation	X	N/A
<b>Hose</b>		
Diameter	X	X
<b>Hose assemblies</b>		
Proof pressure	X	X
Bend	X	N/A
Sequence of hydrostatic tests	X	N/A
Security of end fittings	X	N/A
Change in length	X	X
Burst	X	N/A
Twist	X	X
Crush	X	N/A
Ozone	X	N/A
Thermal ageing	X	N/A
Low temperature flexibility	X	N/A
Electrical resistance	X	X
Leak tightness	X	N/A
X = test carried out; N/A= test not applicable		

## Annex H (informative)

### Batch tests for hoses and hose assemblies

Table H.1 — Batch tests for hoses and hose assemblies

Property	Batch
<b>Hose film &amp; fabric</b>	
Elongation	X
<b>Hose assemblies</b>	
Proof pressure	X
Change in length	X
Twist	X
Bend	X
Security of end fittings	X
Electrical resistance	X
Crush	X
Ozone	X
Thermal ageing	X
Leak tightness	X
X = test carried out	

## Bibliography

- [1] EN 1474-2, *Installation and equipment for liquefied natural gas — Design and testing of marine transfer systems — Part 2: Design and testing of transfer hoses*

---

## BSI - British Standards Institution

BSI is the independent national body responsible for preparing British Standards. It presents the UK view on standards in Europe and at the international level. It is incorporated by Royal Charter.

### Revisions

British Standards are updated by amendment or revision. Users of British Standards should make sure that they possess the latest amendments or editions.

It is the constant aim of BSI to improve the quality of our products and services. We would be grateful if anyone finding an inaccuracy or ambiguity while using this British Standard would inform the Secretary of the technical committee responsible, the identity of which can be found on the inside front cover. Tel: +44 (0)20 8996 9000. Fax: +44 (0)20 8996 7400.

BSI offers members an individual updating service called PLUS which ensures that subscribers automatically receive the latest editions of standards.

### Buying standards

Orders for all BSI, international and foreign standards publications should be addressed to Customer Services. Tel: +44 (0)20 8996 9001. Fax: +44 (0)20 8996 7001 Email: [orders@bsigroup.com](mailto:orders@bsigroup.com) You may also buy directly using a debit/credit card from the BSI Shop on the Website <http://www.bsigroup.com/shop>

In response to orders for international standards, it is BSI policy to supply the BSI implementation of those that have been published as British Standards, unless otherwise requested.

### Information on standards

BSI provides a wide range of information on national, European and international standards through its Library and its Technical Help to Exporters Service. Various BSI electronic information services are also available which give details on all its products and services. Contact Information Centre. Tel: +44 (0)20 8996 7111 Fax: +44 (0)20 8996 7048 Email: [info@bsigroup.com](mailto:info@bsigroup.com)

Subscribing members of BSI are kept up to date with standards developments and receive substantial discounts on the purchase price of standards. For details of these and other benefits contact Membership Administration. Tel: +44 (0)20 8996 7002 Fax: +44 (0)20 8996 7001 Email: [membership@bsigroup.com](mailto:membership@bsigroup.com)

Information regarding online access to British Standards via British Standards Online can be found at <http://www.bsigroup.com/BSOL>

Further information about BSI is available on the BSI website at <http://www.bsigroup.com>.

### Copyright

Copyright subsists in all BSI publications. BSI also holds the copyright, in the UK, of the publications of the international standardization bodies. Except as permitted under the Copyright, Designs and Patents Act 1988 no extract may be reproduced, stored in a retrieval system or transmitted in any form or by any means – electronic, photocopying, recording or otherwise – without prior written permission from BSI.

This does not preclude the free use, in the course of implementing the standard, of necessary details such as symbols, and size, type or grade designations. If these details are to be used for any other purpose than implementation then the prior written permission of BSI must be obtained.

Details and advice can be obtained from the Copyright and Licensing Manager. Tel: +44 (0)20 8996 7070 Email: [copyright@bsigroup.com](mailto:copyright@bsigroup.com)