

Automotive LPG filling system for light and heavy duty vehicles — Nozzle, test requirements and dimensions

The European Standard EN 13760:2003 has the status of a
British Standard

ICS 43.060.40; 75.200

National foreword

This British Standard is the official English language version of EN 13760:2003.

The UK participation in its preparation was entrusted to Technical Committee PVE/19, LPG containers and their associated fittings, which has the responsibility to:

- aid enquirers to understand the text;
- present to the responsible international/European committee any enquiries on the interpretation, or proposals for change, and keep the UK interests informed;
- monitor related international and European developments and promulgate them in the UK.

A list of organizations represented on this committee can be obtained on request to its secretary.

Cross-references

The British Standards which implement international or European publications referred to in this document may be found in the *BSI Catalogue* under the section entitled “International Standards Correspondence Index”, or by using the “Search” facility of the *BSI Electronic Catalogue* or of British Standards Online.

This publication does not purport to include all the necessary provisions of a contract. Users are responsible for its correct application.

Compliance with a British Standard does not of itself confer immunity from legal obligations.

Summary of pages

This document comprises a front cover, an inside front cover, the EN title page, pages 2 to 25 and a back cover.

The BSI copyright notice displayed in this document indicates when the document was last issued.

Amendments issued since publication

Amd. No.	Date	Comments

This British Standard, was published under the authority of the Standards Policy and Strategy Committee on 25 August 2003

© BSI 25 August 2003

ISBN 0 580 42513 4

ICS 43.060.40; 75.200

English version

Automotive LPG filling system for light and heavy duty vehicles - Nozzle, test requirements and dimensions

Dispositif de remplissage GPL pour véhicules légers et
poids lourds - Pistolet: conditions d'essais et dimensions

Füllsysteme an Autogasanlagen für leichte und schwere
Fahrzeuge - Anschlussstutzen, Prüfanforderungen und
Abmessungen

This European Standard was approved by CEN on 25 April 2003.

CEN members are bound to comply with the CEN/CENELEC Internal Regulations which stipulate the conditions for giving this European Standard the status of a national standard without any alteration. Up-to-date lists and bibliographical references concerning such national standards may be obtained on application to the Management Centre or to any CEN member.

This European Standard exists in three official versions (English, French, German). A version in any other language made by translation under the responsibility of a CEN member into its own language and notified to the Management Centre has the same status as the official versions.

CEN members are the national standards bodies of Austria, Belgium, Czech Republic, Denmark, Finland, France, Germany, Greece, Hungary, Iceland, Ireland, Italy, Luxembourg, Malta, Netherlands, Norway, Portugal, Slovakia, Spain, Sweden, Switzerland and United Kingdom.



EUROPEAN COMMITTEE FOR STANDARDIZATION
COMITÉ EUROPÉEN DE NORMALISATION
EUROPÄISCHES KOMITEE FÜR NORMUNG

Management Centre: rue de Stassart, 36 B-1050 Brussels

Contents

Foreword.....	4
1 Scope	5
2 Normative references	5
3 Terms and definitions.....	5
4 Design and construction requirements	6
4.1 General.....	6
4.2 Service gasket.....	7
4.3 Specific requirements	7
4.3.1 Light duty vehicle filling nozzle.....	7
4.3.2 Heavy duty vehicle filling nozzle.....	8
4.4 Requirements for connection and disconnection by rotation	8
4.5 Requirements for connection and disconnection by movement in the longitudinal axis of the filling nozzle (push and pull).....	8
4.6 Requirements for lever operation	8
4.7 Requirements for non-metallic materials	8
5 Test procedures	8
5.1 General.....	8
5.2 Overpressure test	9
5.2.1 General.....	9
5.2.2 Test procedure	9
5.2.3 Interpretation of the test.....	10
5.2.4 Re-testing.....	10
5.3 External leak tests	10
5.3.1 General.....	10
5.3.2 Test of the unconnected filling nozzle.....	10
5.3.3 Test of the connected filling nozzle	11
5.3.4 Production testing	12
5.4 Endurance test	12
5.4.1 General.....	12
5.4.2 Test procedure	12
5.4.3 Test interpretation	12
5.4.4 Re-testing.....	13
5.5 LPG compatibility test (for rubber materials)	13
5.5.1 Test procedure	13
5.5.2 Test interpretation	13
5.5.3 Re-testing.....	13
5.6 Corrosion resistance test.....	13
5.6.1 Test procedure	13
5.6.2 Test interpretation	14
5.6.3 Re-testing.....	14
5.7 Resistance to dry heat test	14
5.7.1 General.....	14
5.7.2 Test procedure	14
5.7.3 Test interpretation	14
5.7.4 Re-testing.....	14
5.8 Ozone ageing test	14
5.8.1 General.....	14
5.8.2 Test procedure	14
5.8.3 Test interpretation	15
5.8.4 Re-testing.....	15
5.9 Temperature cycle test.....	15
5.9.1 Test procedure	15
5.9.2 Test interpretation	15

5.9.3	Re-testing	15
5.10	Drop test	15
5.10.1	Test procedure	15
5.10.2	Test interpretation	16
5.10.3	Re-testing	16
5.11	Electrical continuity test of the filling nozzle.....	16
5.11.1	Test procedure	16
5.11.2	Test interpretation	17
5.11.3	Re-testing	17
5.12	Freezing test.....	17
5.12.1	Test procedure	17
5.12.2	Test interpretation	17
5.12.3	Re-testing	17
6	Markings	17
Annex A	(normative) Critical dimensions of the filling nozzles	19
Annex B	(normative) Critical dimensions of the filling units.....	21
Annex ZA	(informative) Clauses of this European Standard addressing essential requirements or other provisions of EU Directives.	23
Bibliography	25

Foreword

This document EN 13760:2003 has been prepared by Technical Committee CEN/TC 286 "Liquefied Petroleum Gas equipment and accessories", the secretariat of which is held by NSAI.

This European Standard shall be given the status of a national standard, either by publication of an identical text or by endorsement, at the latest by February 2004, and conflicting national standards shall be withdrawn at the latest by February 2004.

This document has been prepared under a mandate given to CEN by the European Commission and the European Free Trade Association, and supports essential requirements of **EU Directive(s)**.

For relationship with EU Directive, see informative Annex ZA, which is an integral part of this document.

Annexes A and B are normative.

This document does not deal with the essential safety requirements of the Directive 97/23/EEC (PED).

In the PED the nozzle is classified as a "pressure accessory". It is intended to be connected to a hose, which is classified as "piping".

- ¾ Article 1, 3.6 of Directive 97/23/EEC excludes equipment classified as no higher than category 1 under article 9 if it is covered by Directive 94/9/EC (ATEX).
- ¾ This document addresses the essential health and safety requirements of Directive 94/9/EC.
- ¾ The category 1 limit is defined in Annex 2 Table 6 of the PED and is a function of the product of DN and PS with a limit of 1 000.
- ¾ Because the design pressure (PS) in this document is 2 500 kPa and the DN of the intended hose is less than 40, the figure of 1 000 in Table 6 is not reached.

According to the CEN/CENELEC Internal Regulations, the national standards organizations of the following countries are bound to implement this European Standard: Austria, Belgium, Czech Republic, Denmark, Finland, France, Germany, Greece, Hungary, Iceland, Ireland, Italy, Luxembourg, Malta, Netherlands, Norway, Portugal, Slovakia, Spain, Sweden, Switzerland and the United Kingdom.

1 Scope

This European Standard specifies the minimum design, construction, test requirements and the critical dimensions for filling nozzles for the dispensing of automotive Liquefied Petroleum Gas (LPG) to vehicles of categories M and N, as defined in EC Directive 70/156, that are fitted with the Euro filling unit (light duty or heavy duty).

2 Normative references

This European Standard incorporates by dated or undated references, provisions from other publications. These normative references are cited at the appropriate places in the text and the publications are listed hereafter. For dated references, subsequent amendments to or revisions of any the publications apply to this European standard only when incorporated in it by amendment or revision. For undated references the latest edition of the publication referred to applies (including amendments).

EN 549, *Rubber materials for seals and diaphragms for gas appliances and gas equipment.*

EN 589, *Automotive fuels - LPG - Requirements and test methods.*

EN 12806, *Automotive liquefied petroleum gas components - Other than containers.*

EN 13463-1, *Non-electrical equipment for potentially explosive atmospheres – Part 1: Basic method and requirements.*

EN ISO 11114-2, *Transportable gas cylinders – Compatibility of cylinder and valve materials with gas contents – Part 2: Non-metallic materials (ISO 11114-2:2000).*

ISO 188, *Rubber, vulcanized or thermoplastic - Accelerated ageing and heat resistance tests.*

ISO 1431-1, *Rubber, vulcanized or thermoplastic - Resistance to ozone cracking – Part 1: Static strain test.*

ISO 6957, *Copper alloys – Ammonia test for stress corrosion resistance.*

ISO 9227, *Corrosion tests in artificial atmospheres - Salt spray tests.*

IEC 68-2-52, *Environmental testing – Part 2: Tests – Test Kb: Salt mist, cyclic (sodium, chloride solution).*

3 Terms and definitions

For the purposes of this European Standard, the following terms and definitions apply:

3.1

pressure

gauge pressure, unless otherwise stated

3.2

design pressure

maximum pressure at which the filling nozzle may be used

3.3

test pressure

pressure to which the component, or an assembly of components, is subjected during the tests

3.4

filling nozzle

mechanical system, fitted to the hose of the dispensing system, consisting of a filling nozzle body, operating mechanism, including sealing elements and a service gasket if required

EN 13760:2003 (E)

3.5

light duty vehicle filling nozzle

filling nozzle intended to fuel vehicles fitted with the light duty vehicle Euro filling unit

3.6

heavy duty vehicle filling nozzle

filling nozzle intended to fuel vehicles fitted with the heavy duty vehicle Euro filling unit

3.7

locking mechanism

component allowing the locking or unlocking operation of the filling nozzle to the filling unit

3.8

service gasket

replaceable gasket ensuring tightness of the connection between the filling nozzle outlet and the filling unit inlet

3.9

torque for connection

torque required to connect the filling nozzle to the filling unit

3.10

torque for disconnection

torque required to disconnect the filling nozzle from the filling unit

3.11

push-on force

force applied in the longitudinal axis of the filling unit to connect the filling nozzle to the filling unit

3.12

pull-off force

force applied in the longitudinal axis of the filling unit to disconnect the filling nozzle from the filling unit

3.13

grip

area where the filling nozzle is held for connection or disconnection

3.14

filling unit

device installed on the outside of the vehicle to receive the filling nozzle and enable the filling of the LPG container

NOTE The filling nozzle as prescribed in this standard is only intended to be used with the Euro filling unit.

4 Design and construction requirements

4.1 General

Any non-electrical equipment, intended for use in a potentially explosive atmosphere, shall comply with the requirements of EN 13463-1. The nozzle shall be designed and constructed according to good engineering practice and in conformity with the required categories for group II equipment to ensure avoidance of any ignition source.

To classify the category of the equipment it shall be subjected to an ignition hazard assessment in accordance with 5.2 of EN 13463-1.

If the nozzle does not contain any effective ignition sources in normal operation it shall be classified as Group II category 3.

The design of the filling nozzle shall ensure that:

- a) it is suitable for use with automotive LPG as specified in EN 589;
- b) it is compatible with the relevant filling unit as specified in EN 12806 in accordance with annex B;

- c) entrapment of fingers and/or cold burns are not possible;
- d) it is not possible to open the valve in the filling nozzle if the filling nozzle is not properly locked and sealed on the filling unit;
- e) it locks in the connected position;
- f) it is not possible to disconnect the filling nozzle from the filling unit unless the filling nozzle valve is closed;
- g) internal blocking due to freezing does not occur;
- h) it is tolerant to the effect of dirt;
- i) it will withstand a torque of 150 % of the mounting torque specified by the manufacturer without damage;
- j) the electrical resistance is 1 k Ω maximum;
- k) the materials in contact with LPG are LPG-compatible;
- l) the external surfaces of the filling nozzle are corrosion resistant or protected against corrosion and are made of materials that do not cause sparks when dropped on a surface;
- m) the minimum lifetime is 100 000 cycles;
- n) the maximum design temperature is 65 °C and the minimum design temperature is –20 °C. For extreme cold operating conditions, a minimum design temperature of –40 °C shall be applied;
- o) the design pressure is 2 500 kPa;
- p) a locking mechanism is incorporated;
- q) the nozzle is provided with a means to securely attach it to the delivery hose.

4.2 Service gasket

The service gasket between the filling nozzle and the filling unit, if required, shall be fitted in the nozzle.

Changing the service gasket shall not result in any LPG release.

The minimum lifetime of the service gasket shall be 20 000 cycles.

4.3 Specific requirements

4.3.1 Light duty vehicle filling nozzle

The release of LPG during disconnection shall be less than 1 cm³ liquid.

The flow-rate through the filling nozzle, at a pressure difference of 70 kPa, shall be at least 60 l/min.

The maximum weight of the filling nozzle shall be 2 kg (including swivel, if fitted).

The external diameter of the filling nozzle shall not exceed 54 mm over a length of at least 82 mm measured from the normal attachment point of the vehicle connector as shown in Figure A.1. This includes protruding ancillaries in any position.

The maximum grip diameter of the filling nozzle shall be 60 mm.

The nozzle shall be designed for one hand operation for connection and disconnection.

4.3.2 Heavy duty vehicle filling nozzle

The release of LPG during disconnection shall be less than 1 cm³ liquid.

The flow-rate through the filling nozzle, at a pressure difference of 50 kPa, shall be at least 200 l/min.

The maximum weight of the filling nozzle shall be 3 kg (including swivel, if fitted).

The external diameter of the outlet side of the filling nozzle shall not exceed 80 mm over a length of at least 64 mm as shown in Figure A.2. This includes protruding ancillaries in any position.

4.4 Requirements for connection and disconnection by rotation

The rotation angle in the longitudinal axis shall not exceed 120 degrees.

The maximum torque for connection and disconnection shall be:

¾ 1,5 N.m for the light duty vehicle filling nozzle,

¾ 25 N.m for the heavy duty vehicle filling nozzle,

at any pressure up to 2 500 kPa in the filling nozzle.

4.5 Requirements for connection and disconnection by movement in the longitudinal axis of the filling nozzle (push and pull)

The maximum push-on force shall be 100 N, at any pressure up to 2 500 kPa in the filling nozzle.

The maximum pull-off force shall be 50 N, at a pressure of 2 500 kPa.

4.6 Requirements for lever operation

The force to close the lever, applied at the centre of the grip area of the lever, shall be 50 N maximum at any pressure up to 2 500 kPa in the filling nozzle.

Provision shall be made to enable the lever or the whole filling nozzle to freely rotate over an angle of 360 degrees around the longitudinal axis of the filling nozzle or the filling hose.

4.7 Requirements for non-metallic materials

All elastomer materials in contact with LPG shall be compatible with LPG in accordance with EN ISO 11114-2 and shall not distort, harden or adhere to the body or seat face to such an extent as to impair the function of the valve. Rubber materials shall conform to the requirements of EN 549, see 5.5.

5 Test procedures

5.1 General

The filling nozzle shall be tested in accordance with Table 1.

Table 1 — Production and prototype tests

Test	Prototype test	Production test	Clause
Overpressure	X		5.2
External leak	X	X	5.3
Endurance	X		5.4
LPG compatibility (for rubber materials)	X		5.5
Corrosion resistance	X		5.6
Resistance to dry heat	X		5.7
Ozone ageing	X		5.8
Temperature cycle	X		5.9
Drop test	X		5.10
Electrical continuity	X		5.11
Freezing	X		5.12

The tolerances for test temperatures and pressures shall be:

- ¾ for low temperature : (+0 -5) °C;
- ¾ for high temperature : (+ 5 -0) °C;
- ¾ for 20 °C : ± 5 °C;
- ¾ test pressures : ±10 % of the stated value with a maximum of 100 kPa.

5.2 Overpressure test

5.2.1 General

The endurance test shall be performed before the overpressure test.

The test pressure applied shall be 2,25 times the design pressure.

The test shall be performed at 20 °C.

5.2.2 Test procedure

The outlet of the filling nozzle shall be connected to the filling unit for which the filling nozzle is designed. The outlet of the filling unit shall be plugged.

The test medium shall be water or any other suitable liquid.

The pressure shall be raised at a maximum rate of 1 000 kPa per minute until the test pressure is reached.

The test pressure shall then be maintained for at least 1 minute.

5.2.3 Interpretation of the test

The filling nozzle shall withstand the overpressure test without any visible evidence of rupture or permanent distortion.

5.2.4 Re-testing

If the filling nozzle fails the test, two additional filling nozzles shall be submitted to an overpressure test.

If both filling nozzles pass the test, the test is successful.

If one or both fail the re-test, the filling nozzle design shall be rejected.

5.3 External leak tests

5.3.1 General

An overpressure test and an endurance test shall be performed before the external leak test.

The leak tests in 5.3.2 and 5.3.3 shall be performed at the pressures required in the Table 2.

Table 2 — Leak test pressures

	Low temperatures : -20 °C (alternative : -40 °C)	High temperature : 65 °C	20 °C
Filling nozzle unconnected	100 kPa and 3 750 kPa	100 kPa and 3 750 kPa	20 kPa and 3 750 kPa
Connected filling nozzle and filling unit	100 kPa and 3 750 kPa	100 kPa and 3 750 kPa	20 kPa and 3 750 kPa

5.3.2 Test of the unconnected filling nozzle

5.3.2.1 Test procedure

The unconnected filling nozzle shall be tested at -20 °C (or -40 °C), 20 °C and at 65 °C in accordance with the following procedure:

- pressurise the filling nozzle at the inlet with air or nitrogen at the pressures listed in Table 2;
- immerse the filling nozzle in a suitable test liquid; water for tests at 20 °C and 65 °C; alcohol for tests at -20 °C (or -40 °C). The filling nozzle and the test medium shall be preconditioned for at least 4 hours at each test temperature.
- maintain the test pressure for two minutes;
- determine the leak rate if bubbles are visible.

5.3.2.2 Leak rate determination

The leak rate shall be determined according to the following method or any other equivalent method.

A graduated cylinder that is calibrated in cubic centimetres, filled with the test liquid, shall be placed inverted above the component.

At the end of the test period, the liquid displacement in the graduated cylinder is recorded.

The leakage rate is then calculated using the following formula:

$$V_l = V_t \frac{60}{t} \frac{273 P}{101,6 T}$$

Where:

- V_l is the leakage rate, cm³/hour of air or nitrogen;
- V_t is the liquid displacement during the test in cm³;
- t is the time of test, minutes;
- P is the atmospheric pressure during test in kPa;
- T is the ambient temperature during test in K.

5.3.2.3 Test interpretation

If no bubbles are visible, the filling nozzle passes the test.

If bubbles are detected, the leak rate shall not exceed 15 cm³/hour.

5.3.2.4 Re-testing

If the filling nozzle fails the test, two additional filling nozzles shall be submitted to an external leak test.

If both filling nozzles pass the test, the test is successful.

If one or both fail the re-test, the filling nozzle design shall be rejected.

5.3.3 Test of the connected filling nozzle

5.3.3.1 Test procedure

The connected filling nozzle shall be tested at -20 °C, +20 °C and at 65 °C in accordance with the following procedure:

- a) connect the filling nozzle to a filling unit for which the filling nozzle is designed;
- b) plug the outlet of the filling unit;
- c) pressurise the filling nozzle at the inlet with air or nitrogen at the pressures listed in Table 2;
- d) immerse the connected filling nozzle in a suitable test liquid : water for tests at 20 °C and 65 °C, and alcohol for test at -20 °C (or -40 °C); The connected filling nozzle and the test medium shall be preconditioned at least for 4 hours at each test temperature;
- e) maintain the test pressure for two minutes;
- f) determine the leak rate if bubbles are visible, see 5.3.2.2.

5.3.3.2 Test interpretation

If no bubbles are visible, the filling nozzle passes the test.

If bubbles are detected, the leak rate shall not exceed 15 cm³/h.

5.3.3.3 Re-testing

If the filling nozzle fails the test, two additional filling nozzles shall be submitted to an external leak test.

If both filling nozzles pass the test, the test is successful.

If one or both fail the re-test, the filling nozzle design shall be rejected.

5.3.4 Production testing

After production, each assembled filling nozzle shall be tested according to procedure in 5.3.2 and 5.3.3 at the design pressure and at 20 °C without preconditioning.

The filling nozzles that fail the test shall be rejected or repaired and re-tested.

5.4 Endurance test

5.4.1 General

An endurance test shall be carried out at the design pressure and at 20 °C with air or nitrogen.

5.4.2 Test procedure

The test shall be carried out as follows:

- a) connect the pressurised filling nozzle to a filling unit for which the filling nozzle is designed;
- b) idling time between connecting and disconnecting: a minimum of 3 seconds;
- c) disconnect;
- d) repeat a) to c) 100 000 times.

Precautions shall be taken to avoid large temperature variations of the filling nozzle.

The service gasket shall be replaced every 20 000 cycles.

Before and after changing the service gasket and at the end of the test, an external leak test of the connected filling nozzle at 20 °C shall be performed.

At the end of the test, an external leak test of the unconnected filling nozzle at 20 °C shall also be performed.

NOTE Replacement of the filling unit is permitted every 10 000 cycles.

The release volume at disconnection shall be measured at the end of the test.

After the test, a visual examination of all components of the filling nozzle shall be carried out.

5.4.3 Test interpretation

The filling nozzle shall pass the test if:

- a) it shows no deformation or excessive wear likely to indicate an early failure of any component of the filling nozzle,
- b) it complies with requirements of the external leak test at 20 °C,
- c) it complies with requirements of the connected filling nozzle with the used service gasket at 20 °C, and
- d) it does not have a release volume greater than 1 cm³.

5.4.4 Re-testing

If the filling nozzle fails the test, two additional filling nozzles shall be submitted to an endurance test.

If both filling nozzles pass the test, the test is successful.

If one or both fail the re-test, the filling nozzle design shall be rejected.

5.5 LPG compatibility test (for rubber materials)

5.5.1 Test procedure

The immersion test shall be carried out with pentane in accordance with EN 549.

5.5.2 Test interpretation

The material shall pass the test if the maximum increase in volume measured immediately after the immersion test in accordance with EN 549 does not exceed 10 % and the loss of weight after drying does not exceed 5 %.

5.5.3 Re-testing

If the material fails the test, two additional samples shall be submitted to the LPG compatibility test.

If both samples pass the test, the test is successful.

If one or both fail the re-test, the material shall be rejected.

5.6 Corrosion resistance test

5.6.1 Test procedure

5.6.1.1 Test procedure for a metallic part of the filling nozzle

Any metallic part of the filling nozzle, subject to LPG pressure and exposed to corrosive conditions during its normal life, shall be submitted to 144 hours salt spray test in accordance with ISO 9227 or to a salt spray test in accordance with IEC 68-2-52 Kb.

Before the test the part shall be degreased. Subsequently the part shall be sprayed for 2 hours with a salt solution containing 5 % NaCl (by mass) with less than 0,3 % contamination and 95 % distilled or demineralised water, at a temperature of 20 °C. After spraying, the part shall be stored at a temperature of 40 °C and 90 % to 95 % relative humidity for 168 hours.

This sequence shall be repeated 4 times.

Following this, the part shall be cleaned and dried for 1 hour at 55 °C.

The part shall be conditioned to 20 °C for 4 hours.

The tested part shall be reinstalled in a filling nozzle and the filling nozzle shall be subjected to the external leak tests at 20 °C.

5.6.1.2 Additional test procedures for copper or brass parts

A copper or brass part, subject to LPG pressure, shall be tested in ammonia for 24 hours in accordance with ISO 6957.

A brass part shall be immersed for 30 minutes in an aqueous mercurous nitrate solution containing 10 gram of mercurous nitrate and 10 ml of nitric acid per litre of solution (see ASTM B154).

Following these tests, the part shall be visually inspected and installed in a filling nozzle, which shall be subjected to the external leak tests at 20 °C.

5.6.2 Test interpretation

The part shall pass the test if no stress corrosion cracking is visible and the filling nozzle, with the tested part installed, passes the external leak test.

5.6.3 Re-testing

If the part fails the test, two additional samples shall be submitted to the corrosion tests.

If both samples pass the tests, the test is successful.

If one or both fail the re-test, the part shall be rejected.

5.7 Resistance to dry heat test

5.7.1 General

Any non-metallic part, subject to LPG pressure and to atmospheric conditions, shall be submitted to the resistance to dry heat test.

5.7.2 Test procedure

The test shall be carried out in accordance with ISO 188. The test piece shall be exposed to air at 65 °C for 168 hours.

5.7.3 Test interpretation

The part shall pass the test if the loss of tensile strength does not exceed 25 % and the change in ultimate elongation does not exceed the following values:

¾ maximum increase: 10 %;

¾ maximum decrease: 30 %.

5.7.4 Re-testing

If the part fails the test, two additional samples shall be submitted to the resistance to the dry heat test.

If both samples pass the test, the test is successful.

If one or both fail the re-test, the material shall be rejected.

5.8 Ozone ageing test

5.8.1 General

A non-metallic part, subject to LPG pressure and to atmospheric conditions, shall be submitted to an ozone ageing test.

5.8.2 Test procedure

The test shall be carried out in accordance with ISO 1431-1.

The test piece, stretched by 20 %, shall be exposed to air at 40 °C with an ozone concentration of 50 parts per hundred million, for 72 hours.

5.8.3 Test interpretation

The part shall pass the test if no cracks are visible in the elongated position.

5.8.4 Re-testing

If the part fails the test, two additional samples shall be submitted to the ozone ageing test.

If both samples pass the test, the test is successful.

If one or both fail the re-test, the material shall be rejected.

5.9 Temperature cycle test

5.9.1 Test procedure

A non-metallic part, subject to LPG pressure, shall be submitted to a 120 minutes temperature cycle test, from the minimum design temperature up to the maximum design temperature, at the design pressure, for 96 hours.

After this test, the part shall be fitted in the filling nozzle, which shall be subjected to the external leak tests at 20 °C.

5.9.2 Test interpretation

The part shall pass the test when the filling nozzle, with the tested part, passes the external leak tests.

5.9.3 Re-testing

If the part fails the test, two additional samples shall be submitted to the temperature cycle test.

If both samples pass the test, the test is successful.

If one or both fail the re-test, the material shall be rejected.

5.10 Drop test

5.10.1 Test procedure

A filling nozzle, conditioned at -20 °C (or -40 °C) for 4 hours, shall be connected to a 5 m length of hose with a nominal internal diameter of:

- ¾ 19 mm for the light duty vehicle filling nozzle,
- ¾ 32 mm for the heavy duty vehicle filling nozzle.

The other end of the hose shall be attached to a solid fixing point at a height of 1,3 m.

The filling nozzle shall be:

- a) moved away from the fixing point so that the hose is positioned horizontally;
- b) dropped ten times from the height of 1,3 m, on to a horizontal concrete floor, see Figure 1;
- c) pressurised to the design pressure and subjected to ten additional drops;
- d) submitted to the external leak tests at 20 °C.

Dimensions in metres

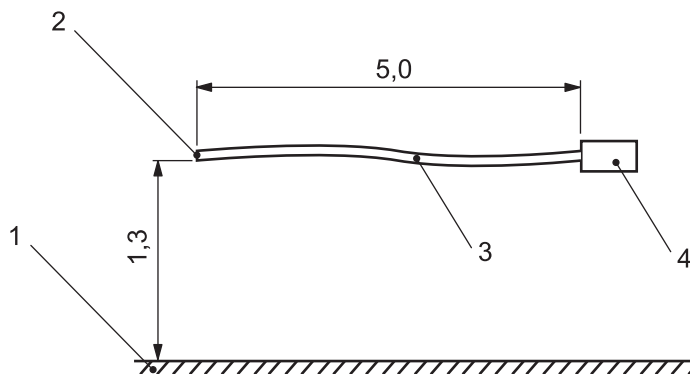
**Key**

- 1 Horizontal concrete floor
- 2 Solid fixing point
- 3 Hose
- 4 Nozzle

Figure 1 — Impact resistance test arrangement**5.10.2 Test interpretation**

The filling nozzle shall pass the test if it passes the external leak tests.

NOTE The above means that the filling nozzle can be satisfactorily connected to the filling unit during the coupled leak test.

5.10.3 Re-testing

If the filling nozzle fails the test, two additional samples shall be submitted to the drop test.

If both samples pass the test, the test is successful.

If one or both fail the re-test, the design of the filling nozzle shall be rejected.

5.11 Electrical continuity test of the filling nozzle**5.11.1 Test procedure**

The electrical continuity through the body of the filling nozzle shall be measured as follows:

- a) connect the filling nozzle to a filling unit for which it has been designed;
- b) connect one probe of an ohm meter with a range of at least 100 Ω to 10 k Ω , to the filling nozzle inlet;
- c) connect the other probe to a point of the filling unit;
- d) measure and record the resistance in ohms;
- e) repeat for four other points on the filling nozzle inlet.

5.11.2 Test interpretation

The filling nozzle shall pass the test if all five electrical resistance measurements do not exceed 1 k Ω .

5.11.3 Re-testing

If the filling nozzle fails the test, two additional samples shall be submitted to the electrical continuity test.

If both samples pass the test, the test is successful.

If one or both fail the re-test, the design of the filling nozzle shall be rejected.

5.12 Freezing test

5.12.1 Test procedure

The test shall be carried out as follows:

- a) connect the filling nozzle to a filling unit for which it is designed;
- b) plug the outlet of the filling unit;
- c) fill the filling nozzle with pentane to which 200 mg/kg of water is added and plug the inlet of the filling nozzle;
- d) condition the assembly to -20 °C for 4 hours;
- e) hold the filling nozzle and the filling unit in the upright position with the filling unit at the bottom;
- f) remove the pentane from the filling nozzle by disconnecting the filling unit from the filling nozzle and remove the plug from the inlet of the filling nozzle;
- g) carry out an external leak test of the unconnected filling nozzle at -20 °C without warming up the filling nozzle during the procedure.

5.12.2 Test interpretation

The filling nozzle shall pass the test if it passes the external leak test at -20 °C.

5.12.3 Re-testing

If the filling nozzle fails the test, two additional samples shall be submitted to the freezing test.

If both samples pass the test, the test is successful.

If one or both fail the re-test, the design of the filling nozzle shall be rejected.

6 Markings

6.1 The filling nozzle shall be marked with at least:

- a) the mark or trade name of the manufacturer;
- b) a reference to the date of manufacturing: YY-MM;
- c) serial number and type or batch number;
- d) the words: "For LPG";
- e) the maximum and minimum design temperature;

EN 13760:2003 (E)

- f) the design pressure;
- g) EN 13760;
- h) any additional marking required according to Clause 14 of EN 13463-1.

NOTE Where applicable, it can be necessary to include the markings as specified in the PED and the ATEX Directives.

6.2 The markings shall be permanent and clearly legible.

Annex A (normative)

Critical dimensions of the filling nozzles

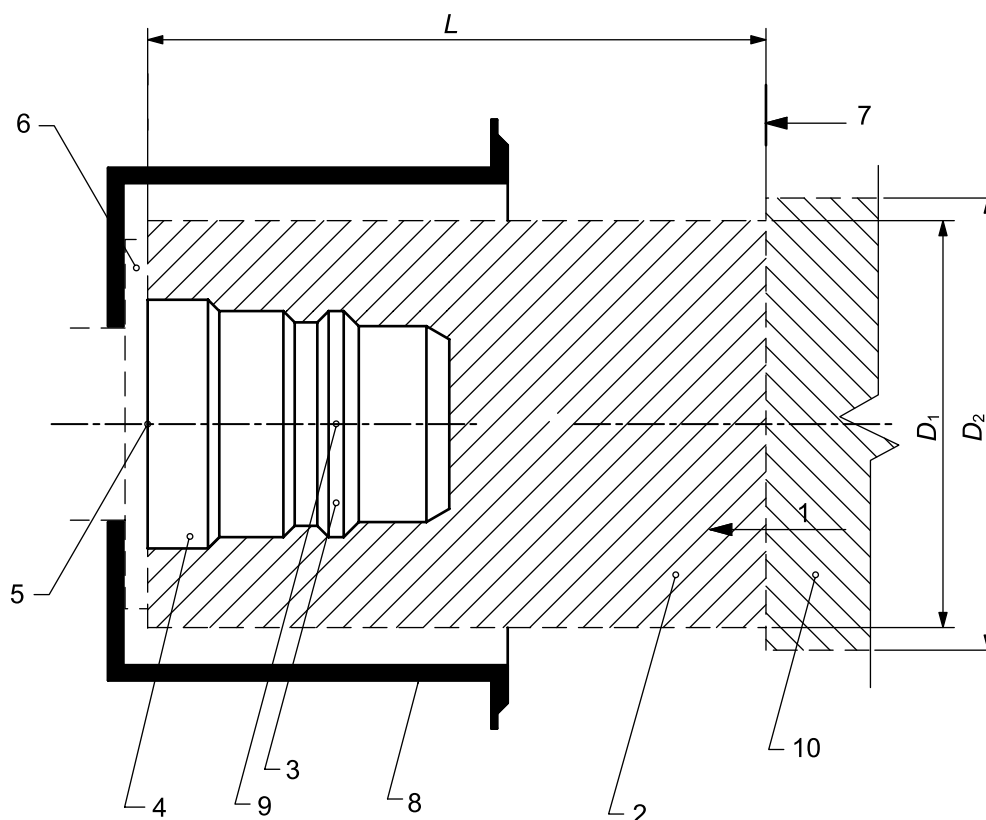

Key

- 1 Fuel flow direction
- 2 Extent of filling nozzle location area
- 3 Connecting part with groove
- 4 Adapters mounting thread area
- 5 Nominal attachment point
- 6 Vehicle filling unit mounting area (not to scale)
- 7 Movement limit of lever for nozzle with protruding device
- 8 Filling unit well (where fitted)
- 9 Point of impact, see EN 12806
- 10 Grip area

Dimensions

- L 82 mm minimum
 D_1 Ø 54 mm maximum
 D_2 Ø 60 mm maximum

Figure A.1 — Critical dimensions of the connected light duty vehicle filling nozzle

Dimensions in millimetres

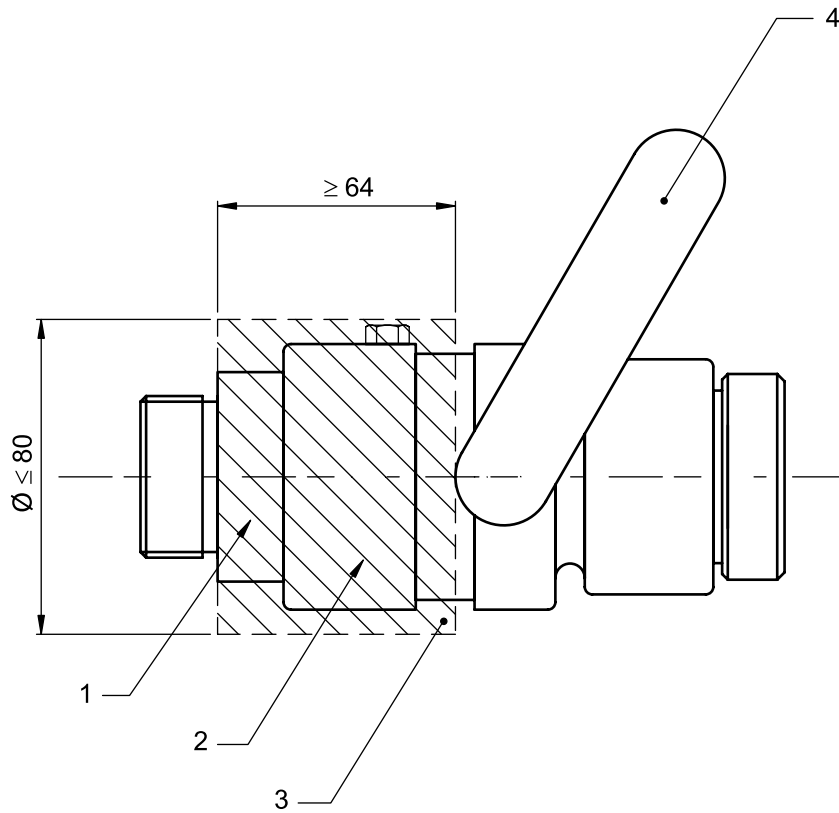

Key

- 1 Filling unit
- 2 Filling nozzle
- 3 Extent of filling nozzle location area
- 4 Optional grip

Figure A.2 — Critical dimensions of the connected heavy duty vehicle filling nozzle

Annex B (normative)

Critical dimensions of the filling units

This annex defines the critical dimensions of the filling units, in accordance with EN 12806, which govern the internal dimensions of the filling nozzles.

Dimensions in millimetres

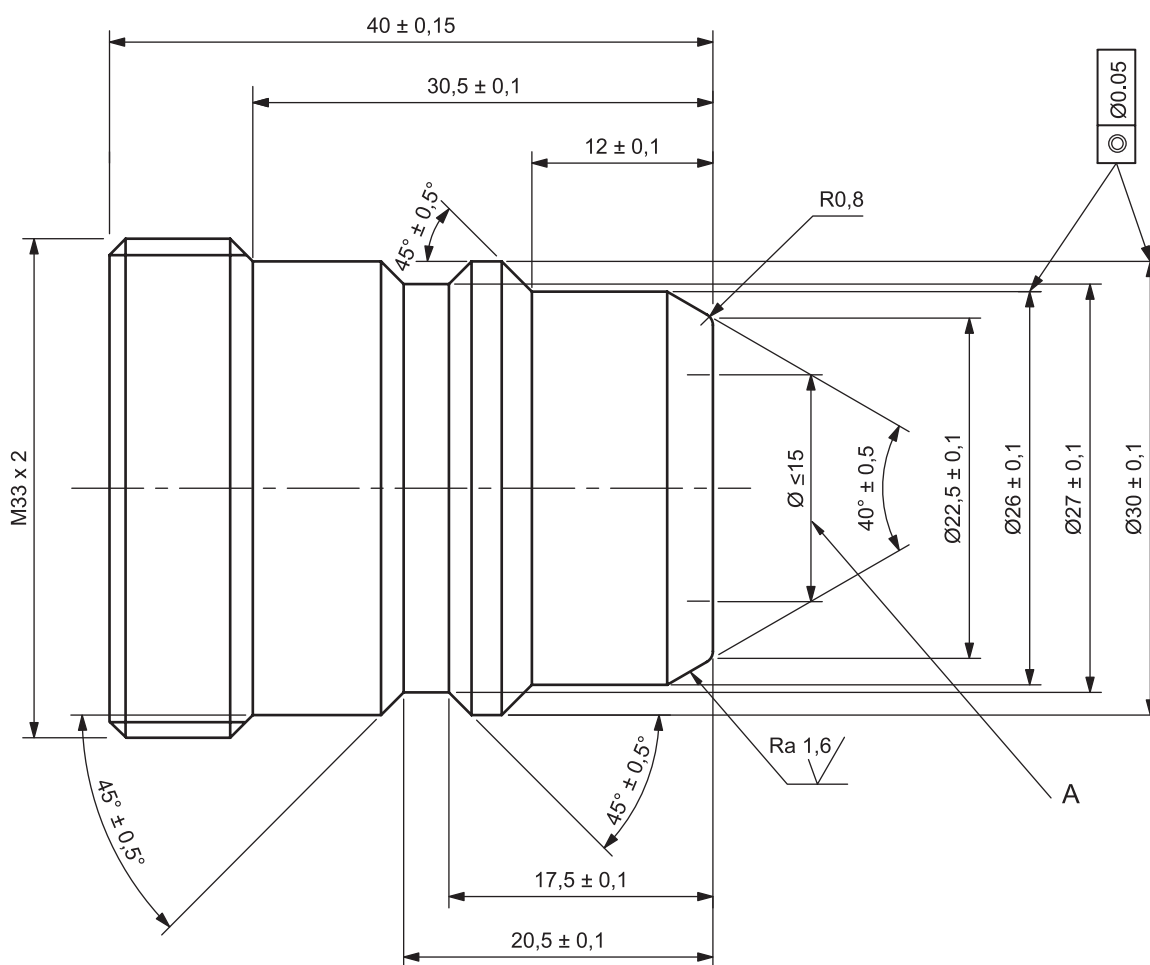

Key

A Maximum valve seat diameter

Figure B.1 — Critical dimensions of the light duty vehicle Euro filling unit

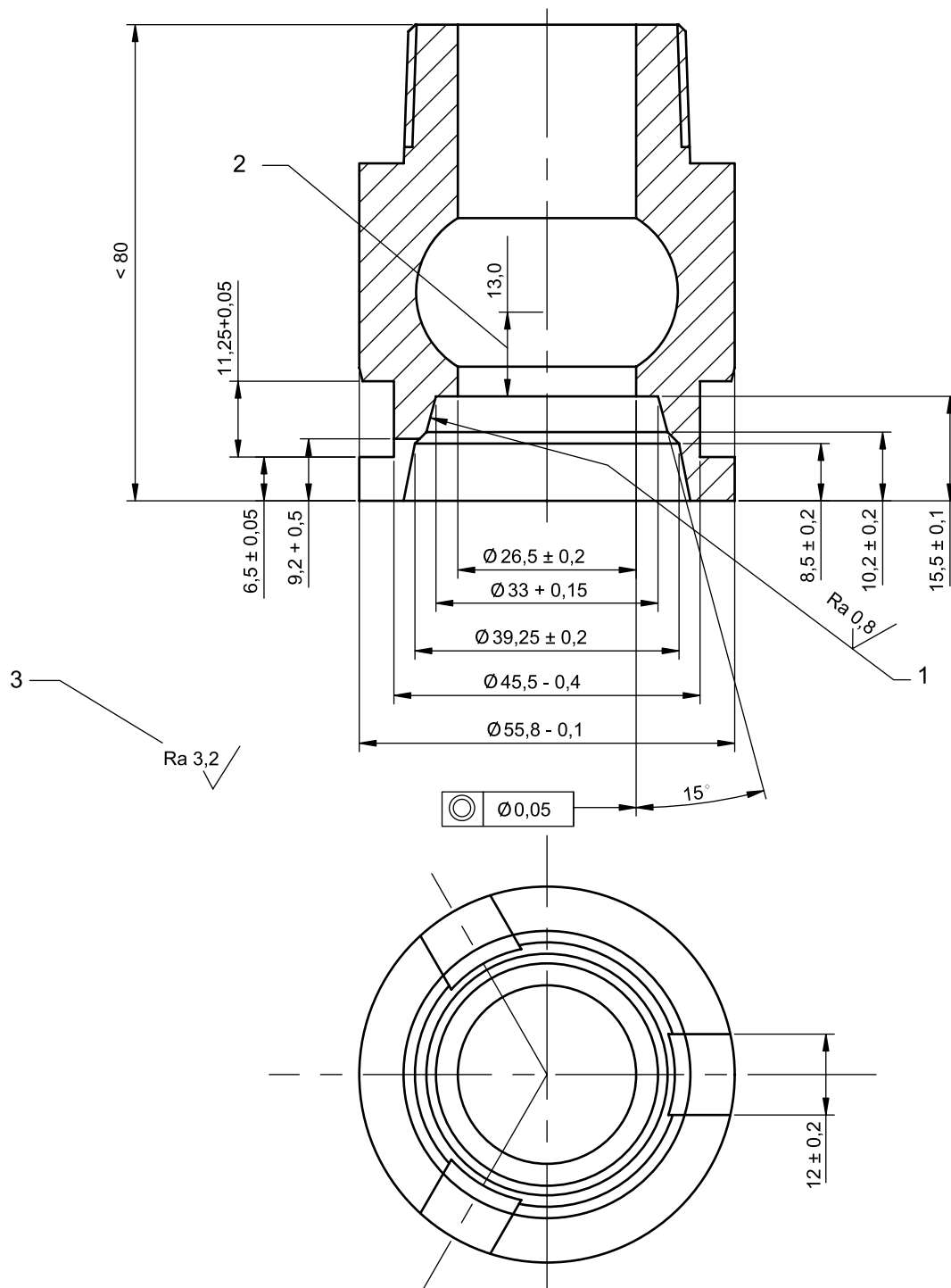

Key

- 1 Nozzle sealing surface
- 2 Minimum valve travel
- 3 General tolerance

Figure B.2 — Critical dimensions of the heavy duty vehicle Euro filling unit

Annex ZA (informative)

Clauses of this European Standard addressing essential requirements or other provisions of EU Directives

This European standard has been prepared under a mandate given to CEN by the European Commission and the European Free Trade Association and supports essential requirements of EU Directive 94/9/EC.

WARNING: Other requirements and other EU Directives may be applicable to the product(s) falling within the scope of this standard.

The following clauses of this standard are likely to support requirements of Directive 94/9/EC.

Relationship with the clauses of this standard provides one means of conforming with the specific essential requirements of the Directive concerned and associated EFTA regulations.

Table ZA.1 — Relationship between this European Standard and Directive 94/9/EC

Essential Requirement	Content	Clauses in this standard
1.0.1	Principles of integrated explosion safety Equipment	4.1, 4.3.1, 4.3.2, 5.1, 5.11
1.0.2	Design for misuse	4.1
1.0.3	Special checking and maintenance conditions	4.2
1.0.5	Marking	6
1.1.1	Materials must not trigger off an explosion	4.1, 5.10, 5.11
1.1.2	No reaction of materials and explosive atmosphere	4.1, 4.7
1.1.3	Material characteristics	4.1, 4.7
1.2.1	Regard to technological knowledge	4.1, 5.10
1.2.3	Prevention of leaks giving rise to explosive atmospheres	4.3.1, 4.3.2
1.2.5	Additional means of protection	4, 5
1.2.7	Protection against other hazards	4, 5
1.3.1	Hazards arising from different ignition sources	4.1, 5.11
1.3.2	Hazards arising from static electricity	5.11
1.4.1	Presence of humidity and contamination	4.1, 5
1.4.2	Mechanical & thermal stress, aggressive substances	4, 5
1.5.1	Independent safety related devices	4.1

Table ZA.1 (continued)

1.5.2	System security in the event of safety device failure	4.1
1.6.1	Manual override of process	4.1
1.6.4	Hazards arising from connections	4.1, 5.4
2.3.1.1	Preventing ignition sources	4.1, 5.11

Bibliography

- [1] EC Directive 70/156, *Council Directive 70/156/EEC of 6 February 1970 on the approximation of the laws of the Member States relating to the type-approval of motor vehicles and their trailers.*
- [2] ASTM B154, *Standard test method for mercurous nitrate test for copper and copper alloys.*
- [3] Directive 97/23/EEC, *Directive 97/23/EC of the European Parliament and of the Council of 29 May 1997 on the approximation of the laws of the Member States concerning pressure equipment.*
- [4] Directive 94/9/EC, *Directive 94/9/EC of the European Parliament and the Council of 23 March 1994 on the approximation of the laws of the Member States concerning equipment and protective systems intended for use in potentially explosive atmospheres.*

BSI — British Standards Institution

BSI is the independent national body responsible for preparing British Standards. It presents the UK view on standards in Europe and at the international level. It is incorporated by Royal Charter.

Revisions

British Standards are updated by amendment or revision. Users of British Standards should make sure that they possess the latest amendments or editions.

It is the constant aim of BSI to improve the quality of our products and services. We would be grateful if anyone finding an inaccuracy or ambiguity while using this British Standard would inform the Secretary of the technical committee responsible, the identity of which can be found on the inside front cover.
Tel: +44 (0)20 8996 9000. Fax: +44 (0)20 8996 7400.

BSI offers members an individual updating service called PLUS which ensures that subscribers automatically receive the latest editions of standards.

Buying standards

Orders for all BSI, international and foreign standards publications should be addressed to Customer Services. Tel: +44 (0)20 8996 9001.
Fax: +44 (0)20 8996 7001. Email: orders@bsi-global.com. Standards are also available from the BSI website at <http://www.bsi-global.com>.

In response to orders for international standards, it is BSI policy to supply the BSI implementation of those that have been published as British Standards, unless otherwise requested.

Information on standards

BSI provides a wide range of information on national, European and international standards through its Library and its Technical Help to Exporters Service. Various BSI electronic information services are also available which give details on all its products and services. Contact the Information Centre.
Tel: +44 (0)20 8996 7111. Fax: +44 (0)20 8996 7048. Email: info@bsi-global.com.

Subscribing members of BSI are kept up to date with standards developments and receive substantial discounts on the purchase price of standards. For details of these and other benefits contact Membership Administration.
Tel: +44 (0)20 8996 7002. Fax: +44 (0)20 8996 7001.
Email: membership@bsi-global.com.

Information regarding online access to British Standards via British Standards Online can be found at <http://www.bsi-global.com/bsonline>.

Further information about BSI is available on the BSI website at <http://www.bsi-global.com>.

Copyright

Copyright subsists in all BSI publications. BSI also holds the copyright, in the UK, of the publications of the international standardization bodies. Except as permitted under the Copyright, Designs and Patents Act 1988 no extract may be reproduced, stored in a retrieval system or transmitted in any form or by any means – electronic, photocopying, recording or otherwise – without prior written permission from BSI.

This does not preclude the free use, in the course of implementing the standard, of necessary details such as symbols, and size, type or grade designations. If these details are to be used for any other purpose than implementation then the prior written permission of BSI must be obtained.

Details and advice can be obtained from the Copyright & Licensing Manager.
Tel: +44 (0)20 8996 7070. Fax: +44 (0)20 8996 7553.
Email: copyright@bsi-global.com.