

BS EN 13757-4:2013



BSI Standards Publication

Communication systems for meters and remote reading of meters

Part 4: Wireless meter readout (Radio meter reading for operation in SRD bands)

bsi.

...making excellence a habit.™

National foreword

This British Standard is the UK implementation of EN 13757-4:2013. It supersedes BS EN 13757-4:2005 which is withdrawn.

The UK participation in its preparation was entrusted to Technical Committee PEL/894, Remote Meter Reading.

A list of organizations represented on this committee can be obtained on request to its secretary.

This publication does not purport to include all the necessary provisions of a contract. Users are responsible for its correct application.

© The British Standards Institution 2013.
Published by BSI Standards Limited 2013

ISBN 978 0 580 76030 3
ICS 33.200; 35.100.10; 35.100.20

Compliance with a British Standard cannot confer immunity from legal obligations.

This British Standard was published under the authority of the Standards Policy and Strategy Committee on 31 August 2013.

Amendments issued since publication

| Date | Text affected |
|------|---------------|
|------|---------------|

EUROPEAN STANDARD

EN 13757-4

NORME EUROPÉENNE

EUROPÄISCHE NORM

August 2013

ICS 33.200; 35.100.10; 35.100.20

Supersedes EN 13757-4:2005

English Version

Communication systems for meters and remote reading of meters - Part 4: Wireless meter readout (Radio meter reading for operation in SRD bands)

Systèmes de communication et de télérelevé des compteurs - Partie 4: Echange de données des compteurs par radio (Lecture de compteurs dans la bande SRD)

Kommunikationssysteme für Zähler und deren Fernablesung - Teil 4: Zählerauslesung über Funk (Fernablesung von Zählern im SRD-Band)

This European Standard was approved by CEN on 29 June 2013.

CEN members are bound to comply with the CEN/CENELEC Internal Regulations which stipulate the conditions for giving this European Standard the status of a national standard without any alteration. Up-to-date lists and bibliographical references concerning such national standards may be obtained on application to the CEN-CENELEC Management Centre or to any CEN member.

This European Standard exists in three official versions (English, French, German). A version in any other language made by translation under the responsibility of a CEN member into its own language and notified to the CEN-CENELEC Management Centre has the same status as the official versions.

CEN members are the national standards bodies of Austria, Belgium, Bulgaria, Croatia, Cyprus, Czech Republic, Denmark, Estonia, Finland, Former Yugoslav Republic of Macedonia, France, Germany, Greece, Hungary, Iceland, Ireland, Italy, Latvia, Lithuania, Luxembourg, Malta, Netherlands, Norway, Poland, Portugal, Romania, Slovakia, Slovenia, Spain, Sweden, Switzerland, Turkey and United Kingdom.



EUROPEAN COMMITTEE FOR STANDARDIZATION
COMITÉ EUROPÉEN DE NORMALISATION
EUROPÄISCHES KOMITEE FÜR NORMUNG

Management Centre: Avenue Marnix 17, B-1000 Brussels

| Contents | | Page |
|---------------------------------------------------------------------------------------------------------------------|---------------------------------------------------|-----------|
| Foreword | | 3 |
| 1 | Scope | 4 |
| 2 | Normative references | 4 |
| 3 | Terms, definitions and abbreviations | 4 |
| 4 | General | 6 |
| 5 | Mode S | 11 |
| 6 | Mode T | 14 |
| 7 | Mode R2 | 18 |
| 8 | Mode C | 21 |
| 9 | Mode N | 24 |
| 10 | Mode F | 27 |
| 11 | Data Link Layer | 29 |
| 12 | Connection to higher protocol layers | 38 |
| Annex A (informative) Frequency allocation and band usage for the 868 MHz band | | 45 |
| Annex B (informative) Flag, assignment of the “unique User/Manufacturer ID”, three letter codes | | 46 |
| Annex C (informative) Frame examples | | 47 |
| Annex D (informative) Example of predictive reception of synchronous messages | | 53 |
| Annex E (informative) Timing diagrams | | 54 |
| Annex F (informative) Counter Mode Flow | | 65 |
| Annex G (informative) Structure of Extended Link Layer | | 66 |
| Bibliography | | 67 |

Foreword

This document (EN 13757-4:2013) has been prepared by Technical Committee CEN/TC 294 "Communication systems for meters and remote reading of meters", the secretariat of which is held by DIN.

This European Standard shall be given the status of a national standard, either by publication of an identical text or by endorsement, at the latest by February 2014, and conflicting national standards shall be withdrawn at the latest by February 2014.

Attention is drawn to the possibility that some of the elements of this document may be the subject of patent rights. CEN [and/or] CENELEC shall not be held responsible for identifying any or all such patent rights.

This document supersedes EN 13757-4:2005.

This document has been prepared under a mandate given to CEN by the European Commission and the European Free Trade Association.

The main changes since EN 13757-4:2005 are as follows:

- Referenced standards have been updated to the most recent versions.
- Terms and definitions were introduced; see Clause 3.
- Mode C, a compact mode, with more efficient data format has been introduced, see Clause 8.
- Mode N, a narrowband mode for the recently enabled dedicated 169 MHz band has been introduced; see Clause 9.
- Mode F, a frequent receive mode for long range communication in the 433 MHz band has been introduced; see Clause 10.
- The definitions for the Data Link Layer have been moved to a common section; see Clause 11. This includes the existing format, frame format A as well as a more efficient coding, frame format B.
- The address field has been changed from always being the meter address to instead always being the sender address; see 11.5.6.
- Synchronised/predictive timing of transmission to reduce power consumption has been introduced; see 11.6.
- Connections to higher protocol layers to take into account the development of other parts of this standard have been introduced; see Clause 12. This introduces an extension of the Data Link Layer and a Transport Layer.
- An informative example of predictive timing has been added; see Annex D.
- Informative Timing diagrams have been added; see Annex E.

According to the CEN-CENELEC Internal Regulations, the national standards organizations of the following countries are bound to implement this European Standard: Austria, Belgium, Bulgaria, Croatia, Cyprus, Czech Republic, Denmark, Estonia, Finland, Former Yugoslav Republic of Macedonia, France, Germany, Greece, Hungary, Iceland, Ireland, Italy, Latvia, Lithuania, Luxembourg, Malta, Netherlands, Norway, Poland, Portugal, Romania, Slovakia, Slovenia, Spain, Sweden, Switzerland, Turkey and the United Kingdom.

1 Scope

This European Standard specifies the requirements of parameters for the physical and the link layer for systems using radio to read remote meters. The primary focus is to use the Short Range Device (SRD) unlicensed telemetry bands. The standard encompasses systems for walk-by, drive-by and fixed installations. As a broad definition, this European Standard can be applied to various application layers.

2 Normative references

The following documents, in whole or in part, are normatively referenced in this document and are indispensable for its application. For dated references, only the edition cited applies. For undated references, the latest edition of the referenced document (including any amendments) applies.

EN 13757-1, *Communication system for meters and remote reading of meters — Part 1: Data exchange*

EN 13757-3:2013, *Communication systems for and remote reading of meters — Part 3: Dedicated application layer*

EN 60870-5-1, *Telecontrol equipment and systems — Part 5: Transmission protocols — Section 1: Transmission frame formats (IEC 60870-5-1)*

EN 60870-5-2, *Telecontrol equipment and systems — Part 5: Transmission protocols — Section 2: Link transmission procedures (IEC 60870-5-2)*

ISO/IEC 646, *Information technology — ISO 7-bit coded character set for information interchange*

CEPT/ERC/REC 70-03, *Relating to the use of short range devices (SRD)*

ETSI EN 300 220-1, V2.4.1:2012, *Electromagnetic compatibility and Radio spectrum Matters (ERM); Short Range Devices (SRD); Radio equipment to be used in the 25 MHz to 1 000 MHz frequency range with power levels ranging up to 500 mW; Part 1: Technical characteristics and test methods*

ETSI EN 300 220-2, V2.4.1:2012, *Electromagnetic compatibility and Radio spectrum Matters (ERM); Short Range Devices (SRD); Radio equipment to be used in the 25 MHz to 1 000 MHz frequency range with power levels ranging up to 500 mW; Part 2: Harmonized EN covering essential requirements under article 3.2 of the R&TTE Directive*

ETSI EN 301 489-1, V1.9.2:2011, *Electromagnetic compatibility and Radio spectrum Matters (ERM); ElectroMagnetic Compatibility (EMC) standard for radio equipment and services; Part 1: Common technical requirements*

ETSI EN 301 489-3, V1.4.1:2002, *Electromagnetic compatibility and Radio spectrum Matters (ERM) — ElectroMagnetic Compatibility (EMC) standard for radio equipment and services — Part 3: Specific conditions for Short-Range Devices (SRD) operating on frequencies between 9 kHz and 40 GHz*

3 Terms, definitions and abbreviations

3.1 Terms and definitions

For the purposes of this document, the following terms and definitions apply.

3.1.1

BER

bit error rate

3.1.2

frame

unit of transmission at the Data Link Layer

3.1.3

FSK

frequency shift keying

3.1.4

FFSK

filtered frequency shift keying

3.1.5

GFSK

gaussian frequency shift keying

3.1.6

individual transmission interval

exact time between two subsequent synchronous or periodical transmissions which changes with each transmission

3.1.7

message

set of data at the Application Layer

3.1.8

nominal transmission interval

average individual transmission interval between all synchronous or periodical messages (new, old or no data content) for wireless meters

3.1.9

NRZ

non-return-to-zero

3.1.10

Other Device

end device exchanging information with a meter

Note 1 to entry: A repeater is not an Other Device, as it is not exchanging information but just passing it on. A multi utility controller is an Other Device. A physical meter may take this role if supporting additional network functions.

3.1.11

PER

packet error rate

3.1.12

PN9

nine bit pseudo-random pattern

Note 1 to entry: The PN9 needs to be designed according to ITU-T Rec O.150.

3.2 Abbreviations

| | |
|--------------|---------------------------------------------------------------|
| CI | Control Information Field |
| Ident. no. | Identification number (serial number) (part of meter address) |
| Manuf. | Manufacturer Acronym (part of meter address) |
| Ver. | Version (part of meter address) |
| Device Type. | Device type (part of meter address) |

| | |
|------------|------------------------------------------|
| ACC | Access number (refer to EN 13757-3) |
| STS | Status (refer to EN 13757-3) |
| Conf. Word | Configuration Word (refer to EN 13757-3) |

4 General

4.1 Introduction

The “meters” may communicate with “other” system components, for example mobile readout devices, stationary receivers, data collectors, multi-utility concentrators or system network components. Such devices are in this document named “Other Device”. For the meter side, it is assumed that the communication function will work without any operator’s intervention or need for battery replacement over the full lifetime of the radio part of the meter. Other components such as the mobile readout or stationary equipment may have a shorter battery lifetime or require an external power supply as dictated by the technical parameters and use.

Several different modes of operation are defined for the communication with the meter. Many of the physical and link layer parameters of these different modes are identical, allowing the use of common hardware and software. However, due to the operational and technical requirements of these modes some parameters will differ.

The name of a mode is specified by a letter and a number. The letter specifies a mode and the number specifies whether the modes supports unidirectional (=1) or bidirectional (=2) data transfer.

- a) “Stationary mode”, mode S is intended for unidirectional or bidirectional communications between the meter and a stationary or mobile device. A special transmit only sub-mode S1 is optimised for stationary battery operated devices with a long header and the sub-mode S1-m is specialised for mobile receivers.
- b) “Frequent transmit mode”, mode T. In this mode, the meter transmits a very short frame (typically 3 ms to 8 ms) every few seconds, thus allowing walk-by and/or drive-by readout.

Transmit only sub-mode T1. It is the minimal transmission of a meter ID plus a readout value, which is sent periodically.

The bidirectional sub-mode T2 transmits frequently a short frame containing at least its ID and then waits for a very short period after each transmission for the reception of a response. The reception of a response will open a bidirectional communication channel. Alternatively, the initial frame contains the readout value as well, and the response is a reverse channel only used for special services.

- c) “Frequent receive mode”, mode R. In this mode only R2 is relevant, as R1 makes no sense. The meter listens every few seconds for the reception of a wakeup message from a mobile transceiver. After receiving such a wakeup, the device will prepare for a few seconds of communication dialog with the initiating transceiver. In this mode a “multi-channel receive mode” allows the simultaneous readout of several meters, each one operating on a different frequency channel. This mode is as well applicable to stationary Other Device's.
- d) “Compact Mode” mode C. This mode is similar to mode T but it allows for transmission of more data within the same energy budget and with the same duty cycle. It supports the sub-modes C1 and C2 for unidirectional and bidirectional devices. It is suitable for walk-by and/or drive-by readout. The common reception of mode T and mode C frames with a single receiver is possible.
- e) “Narrowband VHF”, mode N. Optimised for narrowband operation in the 169 MHz frequency band, allocated for meter reading and a few other services. Transmit only sub-modes N1a-f, and bidirectional sub-modes N2a-f. The range of sub-modes can be extended using repeaters. Sub-mode N2g is intended for, but not limited to, long range secondary communication using multi-hop repeaters.

- f) "Frequent receive and transmit mode", mode F. Used in the 433 MHz frequency band for long range communications. In the bidirectional sub-modes F2-m, the meter listens every few seconds for the reception of a wake up message from a stationary or mobile transceiver. After receiving such a wake up message, the device prepares for a few seconds of communication dialog with the initiating transceiver. The bidirectional sub-mode F2 transmits a frame and waits for a short period for the reception of a response. The response will open for bidirectional communication.

Meters or other communication devices may support one, multiple or all of the described modes.

NOTE Additional modes, supporting repeating and routing of data, are specified in EN 13757-5.

The detailed handling of broadcast and multicast transmissions is not specified in this standard. The transmission shall be interpreted as multicast if no Extended Link Layer or Transport Layer is used.

4.2 Meter communications types

Table 1 describes the key features of each mode and sub-mode.

Table 1 — Meter communication type

| Modes and sub-modes | WAY | Typical application | Chip-rate kcps | Maximum duty cycle ^a | Data coding + header | Description |
|---------------------|-----|-------------------------------------------------------------------|------------------------------------------------------------|---------------------------------|--------------------------------------------------------|-------------------------------------------------------------------------------------------------------------------------------------------------------------------------------------------------------------------------------------------------------------------------------------------------------------------------------------------------------------------------------------------------------------------------------------------------------------------------------------------------------------------------------------------------------------|
| S1 | 1 | Transmit only meter for stationary receiving readout | 32,768 | 0,02 % ^b | Manchester and long header | Transmit only; transmits a number of times per day to a stationary receiving point. Transmits in the 1 % duty cycle frequency band. Due to long header, it is suitable also for battery economised receiver. |
| S1-m | 1 | Transmit only meter for mobile or stationary readout | 32,768 | 0,02 % ^b | Manchester and short header | Transmit only; transmits with a duty cycle limitation of 0,02 % per hour to a mobile or stationary receiving point. Transmits in the 1 % duty cycle frequency band. Requires a continuously enabled receiver. |
| S2 | 2 | All meter types. Stationary readout | 32,768 | 1 % | Manchester and short header or optionally long header | Meter unit with a receiver either continuously enabled or synchronised requiring no extended preamble for wakeup. Also usable for node transponders or concentrators. A long header is optional. |
| T1 | 1 | Frequent transmission (short frame meters) | 100 | 0,1 % | 3 to 6 and short header | Transmit only with short data bursts typically 3 ms to 8 ms every few seconds, operates in the 0,1 % duty cycle frequency band. |
| T2 | 2 | Frequent transmission (short frame meter with two way capability) | Meter to Other Device: 100 Other Device to Meter 32,768 | 0,1 % 1 % | 3 to 6 and short header Manchester and short header | Meter unit transmits on a regular basis like Type T1 and its receiver is enabled for a short period after the end of each transmission and locks on, if an acknowledge (at 32,768 kcps) is received. Further bidirectional communication in the 0,1 %-frequency band using 100 kcps (meter transmit) and 32,768 kcps (meter receive) may follow. Note that the communication from the meter to the "other" component uses the physical layer of the T1 mode, while the physical layer parameters for the reverse direction are identical to the S2-mode. |
| R2 | 2 | Frequent reception (long range) | 4,8 | 1 % | Manchester and medium header | Meter receiver with possible battery economiser, requiring extended preamble for wake-up. Optionally, it may have up to 10 frequency channels with a high precision frequency division multiplexing. Meter response with 4,8 kcps wake-up followed by a 4,8 kcps header. |
| C1 | 1 | Frequent transmit only | 100 | 0,1 % | NRZ | Transmit only, on a regular basis, with short data bursts < 22 ms, operates in the 0,1 % duty cycle frequency |

| Modes and sub-modes | WAY | Typical application | Chip-rate kcps | Maximum duty cycle ^a | Data coding + header | Description |
|---------------------|-----|----------------------------------------------------------|-------------------------------------------------------------|-----------------------------------------------------------------|------------------------------|-----------------------------------------------------------------------------------------------------------------------------------------------------------------------------------------------------------------------------------------------------------------------------------------------------|
| | | meter for mobile or stationary readout | | | + Short header | band. |
| C2 | 2 | Frequent transmit meter for mobile or stationary readout | Meter to Other Device: 100 Other Device to Meter: 50 | Meter to Other Device: 0,1 % Other Device to Meter: 10 % | NRZ + Short header | Meter unit transmits on a regular basis like Type C1 and its receiver is enabled for a short period after the end of each transmission and locks on if a proper preamble and synchronisation word is detected. Data frames received by the meter are used for protocol updates and commands. |
| N1a-f | 1 | Long range transmit for stationary readout. | 2,4 or 4,8 | 10 % ^c | NRZ | Transmit only; transmits on a regular basis to a stationary receiving point. |
| N2a-f | 2 | Long range two-way communication for stationary readout. | 2,4 or 4,8 | 10 % ^c | NRZ | Meter unit transmits on a regular basis like mode N1 and its receiver is enabled for a short period after the end of each transmission and locks on if a proper preamble and synchronisation word is detected. |
| N2g | 2 | Long range communication | 9,6 (19,2 kbps) | 10 % ^c | NRZ | Secondary communication using multi-hop repeaters, or bidirectional communication similar to mode N2a-f. |
| F2-m | 2 | Long range two-way communication | 2,4 | 10 % | NRZ | Meter receiver with possible battery economiser, requiring extended preamble for wake-up. |
| F2 | 2 | Long range two-way communication for stationary readout. | 2,4 | 10 % | NRZ | Meter unit transmits on a regular basis. Its receiver is enabled for a short period after the end of each transmission. It locks on if a proper preamble and synchronisation word is detected. |
| All | | Multi-mode option | | | | A system component may operate simultaneously, sequentially or by command in more than one mode as long as it fulfils all the requirements of each of these modes. |

^a The duty cycle limitation shall conform to the frequency band allocation defined for operation in the applicable frequency bands according to CEPT/ERC/REC 70-03.

^b The total occupancy of the channel shall be limited to < 10 %. This implies that the duty cycle per meter shall be limited to 0,02 % per hour with 500 metering devices installed within transmission range.

^c The duty-cycle limit is according to EU Commission Decision 2005/928/EC.

Figure 1 below illustrates the operation between the different modes and components.

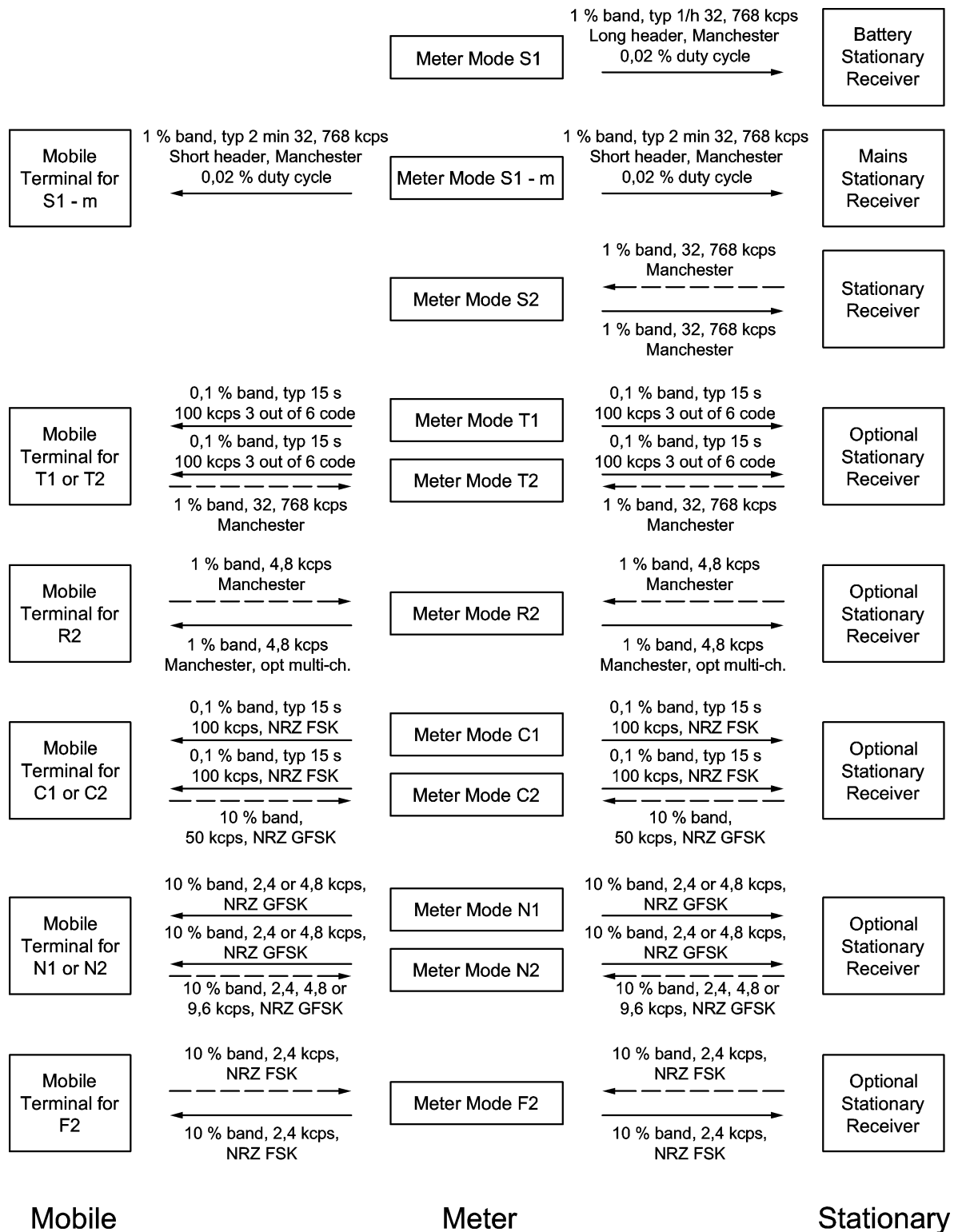

Figure 1 — Meter communication types

4.3 Performance Classes

The transmitters shall belong to one of three Classes ranging from low and medium to high radiated power (see Table 2).

The maximum allowable radiated power for the transmitter is defined by CEPT/ERC/REC 70-03 or as permitted by local radio regulation.

When existing, the receiver shall belong to one of three Classes in sensitivity and blocking performance; from low and medium to high (see Table 3).

The performance Class of receivers and transmitters defines power, sensitivity and selectivity. The performance Class of the transmitter and the receiver may be different.

The transmission power shall be measured as the effective radiated power (ERP) according to 7.3 of ETSI EN 300 220-1, V2.4.1:2012.

The maximum usable sensitivity shall be measured according to 8.1 of ETSI EN 300 220-1, V2.4.1:2012.

Table 2 — Transmitter performance Classes

| Transmitter Class | Typical application | Description | Minimum ERP P_{erp} |
|-------------------|---------------------|----------------------------|-------------------------------------------------------------------------------------------------------------------------------------------------------------------------------------------------------|
| L_T | Lowest performance | Limited transmission power | -5 dBm (all but mode N) 0 dBm (mode N) |
| M_T | Medium performance | Medium transmission power | 0 dBm (all but mode N) 10 dBm (mode N) |
| H_T | Highest performance | Highest transmission power | Meter to Other Device +5 dBm (mode R, S, T, C) Meter to Other Device +3 dBm (mode F) Other Device to Meter +8 dBm (mode R, S, T, C) Other Device to Meter +7 dBm (mode F) 20 dBm (mode N) |

Table 3 — Receiver performance Classes

| Receiver Class | Typical application | Description | Maximum usable sensitivity P_0 | Antenna gain dBi G_a |
|-----------------------------------------------------------------------------------------------------------------|---------------------|----------------------------------------------------|------------------------------------------------------------------|------------------------------|
| L_R | Lowest performance | Limited sensitivity, minimum blocking performances | -80 dBm (mode R,S,T,C) -90 dBm (mode N) -105 dBm (mode F) | a |
| M_R | Medium performance | Medium sensitivity, good blocking performances | -90 dBm (mode R,S,T,C) -100 dBm (mode N) -110 dBm (mode F) | a |
| H_R | Highest performance | Best sensitivity and best blocking performances | see, Table 6, Table 9, Table 13, Table 16, Table 20 and Table 23 | a |
| ^a Refer to 8.1 and for integral or dedicated antenna, refer to E.2 in ETSI EN 300 220-1 V2.4.1:2012. | | | | |

5 Mode S

5.1 Mode S: General

The radio part of a meter shall, for all parameters, as a minimum conform to the requirements of ETSI EN 300 220 parts 1 and 2 even if some application requires extended temperature or voltage range. The specific requirements for frequency band duty cycle are given in Table 4.

Table 4 — Mode S, General

| Characteristic | Min | Typical | Max | Unit |
|---------------------------------------------------------------------------------------------------------------------------------------------------------------------------------------------------------------------------------------------------------------------------------------------------------------------------------------------------------------------------------------|-------|---------|-------|------|
| Frequency band ^a | 868,0 | 868,3 | 868,6 | MHz |
| Transmitter duty cycle S2 ^b | | 0,02 | 1 | % |
| Transmitter duty cycle S1 & S1-m ^c | | | 0,02 | % |
| ^a This European Standard is optimised for the 868 MHz to 870 MHz band, although with an appropriate transmission licence, other frequency bands could be used. ^b Duty cycle as defined by ETSI EN 300 220-1, V2.4.1:2012. ^c The duty cycle is limited to 0,02 % per hour to limit the total occupancy of the channel, see Table 1, Footnote b. | | | | |

NOTE See Figure A.1 for additional information on frequency and power recommendations.

5.2 Mode S: Transmitter

The parameters for the transmitter shall be as listed in Table 5 below:

Table 5 — Mode S, Transmitter

| Characteristic | Mode | Symbol | min. | Type | max. | Unit | Note |
|-------------------------------------------------------------------------|--------------|-------------------|-----------------------------|--------------------------------------|-----------------------------|-------|-----------------------------------|
| Centre frequency (transmit only Meter, S1- submode) | | | 868,25 | 868,30 | 868,35 | MHz | $\sim 60 \times 10^{-6}$ (ppm) |
| Centre frequency (Other Device and S2-mode) | | | 868,278 | 868,300 | 868,322 | MHz | $\sim 25 \times 10^{-6}$ (ppm) |
| FSK Deviation | | | ± 40 | ± 50 | ± 80 | kHz | |
| Chip rate transmit | | f_{chip} | | 32,768 | | kcps | |
| Chip rate tolerance | | | | | $\pm 1,5$ | % | |
| Digital bit jitter ^a | | | | | ± 3 | us | |
| Data rate (Manchester) ^b | | | | $f_{\text{chip}} \times \frac{1}{2}$ | | bps | |
| Preamble length including bit/byte-sync, both directions | S2, S1- M | | 48 | | | chips | |
| Preamble length including bit/byte-sync | S1 | PL | 576 | | | chips | Optional for S2 |
| Postamble (trailer) length ^c | | | 2 | | 8 | chips | |
| Response delay ^d (Other Device to Meter communication) | | t_{RO} | 3 | | 50 | ms | |
| FAC Transmission delay ^{e f} | S2 | t_{TxD} | $N \times 1\,000$ $-0,5$ | $N \times 1\,000$ | $N \times 1\,00$ $0+0,5$ | ms | $N=2, 3, \text{or } 5$ |
| FAC Time out ^g | S2 | t_{TO} | 25 | | 30 | s | |

^a The bit jitter shall be measured at the output of the micro-controller or encoder circuit.

^b Each bit shall be coded as 2 chips (Manchester encoding).

^c The postamble (trailer) shall consist of $n=1$ to 4 "ones" i.e. the chip sequence is $n \times (01)$.

^d Response delay: The receiver shall be ready for the reception of a response in a time shorter than the minimum response delay, and shall be receiving at least until the maximum response delay (referred to the end of previous transmission).

^e FAC Transmission delay: describes the duration which a meter shall delay the first response to a received message from Other Device referred to its last transmission. This delay shall also be applied between the first response of the Meter and the next repeated response of the Meter and all following repeated responses during the Frequent Access Cycle (FAC). The reference time point shall be the end of preamble (end of sync sequence) of the meter transmission. For timing diagrams see Annex E.

^f The selected timeslot N shall be the same throughout the Frequent Access Cycle.

^g FAC Time out: is the time period between the last successful reception of a frame from the Other Device during the Frequent Access Cycle (FAC) and the moment where the repetition of the last response of the Meter shall be stopped (end of Frequent Access Cycle).

5.3 Mode S: Receiver

The parameters for the receiver shall be as listed in Table 6 below.

Table 6 — Mode S, Receiver

| Characteristic | Class | Symbol | min. | Type | max. | Unit | Note |
|-------------------------------------------------------------------|----------------|--------------------|------|--------|------|----------|------|
| Sensitivity (BER < 10 ⁻²) or (PER < 0,8) ^a | H _R | P _O | -100 | -105 | | dBm | |
| Blocking performance ^b | L _R | | 3 | | | Category | |
| Blocking performance ^{b c} | M _R | | 2 | | | Category | |
| Blocking performance ^{b c d} | H _R | | 2 | | | Category | |
| Acceptable chip rate tolerance | | D _{fchip} | | | ± 2 | % | |
| Chip rate (Meter) | | f _{chip} | | 32,768 | | kcps | |

^a At a frame size of 20 bytes.
^b Receiver category according to ETSI EN 300 220-1, V2.4.1:2012, 4.1.1.
^c Additional requirement for Class M_R and Class H_R receivers: The equipment shall meet the immunity requirements as specified in ETSI EN 301 489-1, V1.9.2:2011, 9.2.
^d Additional requirement for Class H_R receivers: Adjacent band selectivity shall be > 40 dB when measured according to ETSI EN 300 220-1, V2.4.1:2012, 8.3.

5.4 Mode S: Data encoding

5.4.1 Mode S: Manchester encoding

Manchester encoding shall be used for this mode to allow simple encoding/decoding and occupy a narrower base-band. Each bit shall be encoded as either a "10" chip sequence representing a "zero" or as a "01" representing a "one". The lower frequency shall correspond to a chip value of "0".

5.4.2 Mode S: Order of transmission of the encoded data

Each data byte shall be transmitted with the most significant bit first. The order of multi byte fields is defined in 11.2.

5.4.3 Mode S: Preamble and synchronisation pattern

The total preamble (header + synchronisation) chip sequence for this mode shall be $n \times (01) 0001110110 10010110$:

with $n \geq 279$ for the sub-mode S1 (long header)

with $n \geq 15$ for the sub-mode S2 (short header)

with $n \geq 279$ for the sub-mode S2 optional long header

All chips of each frame, including pre- and postamble, shall form an uninterrupted sequence. After this preamble a frame of the format A shall follow.

NOTE In Manchester coding, the chip sequence 000111 is invalid but it is used near the end of the header to allow a receiver to detect the start of a new or a stronger transmission. This applies even during reception of a weaker transmission. The capture effect allows efficient communication even in a channel where many weak transmitters from a large area might otherwise effectively block the reception of a nearer (stronger) transmitter. In addition, it allows pulsed receivers to distinguish safely between the start of a valid frame and the detection of an accidental "sync" sequence within an ongoing transmission.

6 Mode T

6.1 Mode T: General

The radio part of a meter shall, for all parameters, as a minimum conform to the requirements of ETSI EN 300 220 parts 1 and 2 even if some applications require extended temperature or voltage range. The specific requirements for frequency bands are given in Table 7.

Table 7 — Mode T, General

| Characteristic | Mode | min. | Type | max. | Unit |
|----------------------------------------------------|--------|-------|--------|-------|------|
| Frequency band: Meter to Other Device ^a | T1, T2 | 868,7 | 868,95 | 869,2 | MHz |
| Frequency band: Other Device to Meter ^a | T2 | 868,0 | 868,3 | 868,6 | MHz |

^a This European Standard is optimised for the 868 MHz to 870 MHz band, although with an appropriate transmission licence, other frequency bands could be used.

NOTE See Figure A.1 for additional information on frequency and power recommendations.

6.2 Mode T: Transmitter

The parameters for the transmitter shall be as given in Table 8:

Table 8 — Mode T, Transmitter

| Characteristic | Mode | Symbol | min. | Type | max. | Unit | Note |
|---------------------------------------------------------------------------|--------|--------------------|-----------------------------|-------------------------------|-----------------------------|---------------|-----------------------------------|
| Centre frequency (Meter to Other Device) | T1, T2 | | 868,90 | 868,95 | 869,00 | MHz | $\sim 60 \times 10^{-6}$ (ppm) |
| Centre frequency (Other Device to Meter) | T2 | | 868,278 | 868,300 | 868,322 | MHz | $\sim 25 \times 10^{-6}$ (ppm) |
| FSK Deviation (Meter to Other Device) | T1, T2 | | ± 40 | ± 50 | ± 80 | kHz | |
| FSK Deviation (Other Device to Meter) | T2 | | ± 40 | ± 50 | ± 80 | kHz | |
| Chip rate transmit (Meter to Other Device) | T1, T2 | f_{chip2} | 90 | 100 | 110 | kcps | |
| Rate variation within header + frame (meter) | T1, T2 | D_{fchip} | | 0 | ± 1 | % | |
| Data rate ^a (Meter to Other Device, 3 out of 6 encoding) | T1, T2 | f_{chip2} | | $f_{\text{chip}} \times 2/3$ | | bps | |
| Chip rate transmit (Other Device to Meter) | T2 | | | 32,768 | | kcps | |
| Chip rate tolerance (Other Device to Meter) | T2 | | | | $\pm 1,5$ | % | |
| Digital bit jitter ^b | T2 | | | | ± 3 | μs | |
| Data rate (Other Device to Meter, Manchester encoding) | T2 | | | $f_{\text{chip2}} \times 1/2$ | | bps | |
| Preamble length including bit/byte- sync, both directions | T1, T2 | PL | 48 | | | chips | |
| Postamble (trailer) length ^c | T1, T2 | | 2 | | 8 | chips | |
| Response delay ^d (Other Device to Meter communication) | T2 | t_{RO} | 2 | | 3 | ms | |
| FAC Transmission delay ^{e f} | T2 | t_{TXD} | $N \times 1\,000$ $-0,5$ | $N \times 1\,000$ | $N \times 1\,00$ $0+0,5$ | ms | $N=2, 3, \text{or } 5$ |
| FAC Time out ^g | T2 | t_{TO} | 25 | | 30 | s | |

^a Each nibble (4 bits) shall be coded as 6 chips, see Table 10.

^b The bit jitter shall be measured at the output of the microprocessor or encoder circuit.

^c The postamble (trailer) shall consists of at least two alternating chips. If the last chip of the CRC was a zero, then the minimum postamble shall be "10", otherwise it shall be "01".

^d Response delay: The receiver shall be ready for the reception of a response in a time shorter than the minimum response delay, and shall be receiving at least until the maximum response delay (referred to the end of previous transmission).

^e FAC Transmission delay: describes the duration which a Meter shall delay the first response to a received message from Other Device referred to its last transmission. This delay shall also be applied between the first response of the Meter and the next repeated response of the Meter and all following repeated responses during the Frequent Access Cycle (FAC). The reference time point shall be the end of preamble (end of sync sequence) of the Meter transmission. For timing diagrams see Annex E.

^f The selected timeslot N shall be the same throughout the Frequent Access Cycle.

^g FAC Time out: is the time period between the last successful reception of a frame from the Other Device during the Frequent Access Cycle (FAC) and the moment where the repetition of the last response of the Meter shall be stopped (end of Frequent Access Cycle).

6.3 Mode T2 only: Receiver

The parameters for the receiver shall be as given in Table 9.

Table 9 — Mode T2 only, Receiver

| Characteristic | Mode/ Class | Symbol | min. | Type | max. | Unit | Note |
|-----------------------------------------------------------------------------------------------------------------------------------------------------------------------------------------------------------------------------------------------------------------------------------------------------------------------------------------------------------------------------------------------------------------------------------------------------------------------------------------------------------------------------------|----------------|---------------------|------|--------|------|----------|---------|
| Sensitivity (BER < 10 ⁻²) or (PER < 0,8) ^a | H _R | P _o | -100 | -105 | | dBm | |
| Blocking performance ^b | L _R | | 3 | | | Category | |
| Blocking performance ^{b c} | M _R | | 2 | | | Category | |
| Blocking performance ^{b c d} | H _R | | 2 | | | Category | |
| Acceptable header chip rate range: (Other Device) | T1, T2 | f _{chip} | 88 | 100 | 112 | kcps | ~± 12 % |
| Acceptable chip rate variation during header and frame: (Other Device) | T1, T2 | D _{fchip} | | 0 | ± 2 | % | |
| Chip rate (Meter) | T2 | f _{chip} | | 32,768 | | kcps | |
| Acceptable chip rate tolerance (Meter) | T2 | D _{fchip2} | | 0 | ± 2 | % | |
| ^a At a frame size of 20 bytes. ^b Receiver category according to ETSI EN 300 220-1, V2.4.1:2012, 4.1.1. ^c Additional requirement for Class M _R and Class H _R receivers: The equipment shall meet the immunity requirements as specified in ETSI EN 301 489-1, V1.9.2:2011, 9.2. ^d Additional requirement for Class H _R receivers: Adjacent band selectivity shall be > 40 dB when measured according to ETSI EN 300 220-1, V2.4.1:2012, 8.3. | | | | | | | |

6.4 Mode T: Data encoding

6.4.1 General

In the mode T1 and T2, for optimum fast transmission, the data going from the meter to the reader device (Other Device) shall be encoded by the efficient “3 out of 6” code. In the mode T2, the reader may send back a message to the meter. This message shall be encoded by the Manchester code (see 6.4.3).

6.4.2 Mode T: Meter transmit: “3 out of 6” data encoding

6.4.2.1 General

“3 out of 6” encoding shall be used for the T1 and T2 mode to achieve an improved efficiency compared to Manchester encoding. Unique codes shall be used for specific control functions such as preamble, message start, etc. The encoding shall be performed as given in Table 10.

Each 4-bit nibble of data shall be encoded as a 6-bit word. Only those words, out of the 64 combinations, with an equal number of zeros and ones and with a minimum of two transitions, have been selected.

The lower frequency shall correspond to a chip value of “0”.

Table 10 — Mode T meter transmit, “3 out of 6” data encoding

| NRZ-Code | Decimal | 6-bit code | Decimal | N° of transitions |
|----------|---------|------------|---------|-------------------|
| 0000 | 0 | 010110 | 22 | 4 |
| 0001 | 1 | 001101 | 13 | 3 |
| 0010 | 2 | 001110 | 14 | 2 |
| 0011 | 3 | 001011 | 11 | 3 |
| 0100 | 4 | 011100 | 28 | 2 |
| 0101 | 5 | 011001 | 25 | 3 |
| 0110 | 6 | 011010 | 26 | 4 |
| 0111 | 7 | 010011 | 19 | 3 |
| 1000 | 8 | 101100 | 44 | 3 |
| 1001 | 9 | 100101 | 37 | 4 |
| 1010 | 10 | 100110 | 38 | 3 |
| 1011 | 11 | 100011 | 35 | 2 |
| 1100 | 12 | 110100 | 52 | 3 |
| 1101 | 13 | 110001 | 49 | 2 |
| 1110 | 14 | 110010 | 50 | 3 |
| 1111 | 15 | 101001 | 41 | 4 |

6.4.2.2 Mode T: Meter transmit: Order of transmission of the encoded data

The data coded as “3 out of 6” shall be transmitted with most significant bit (MSB = Left bit of the 6-bit code) first and with the most significant nibble (MSN) first.

Each data byte shall be transmitted with the most significant bit first.

The order of multi byte fields is defined in 11.2.

6.4.2.3 Mode T1 and T2: Meter transmit: Preamble and synchronisation pattern

The total preamble (header + synchronisation) chips sequence for this mode shall be $n \times (01) 0000111101$ with $n \geq 19$. After this preamble, a frame of the format A shall follow.

The chip sequence 0101010101 has been reserved for the transmission preamble so that a receiver can start sampling at the maximum chip rate and then determine the actual chip rate from these patterns. Moreover, the high number of transitions ensures the best detection of the actual chip rate. Within the frame, the maximum number of contiguous zeroes or ones is four, but neither the pattern “00001111” nor the pattern “11110000” will ever occur inside a “3 out of 6” encoded chip sequence. The pattern can therefore be used for synchronisation.

The chip sequence 0101010101 will never occur during a normal chip sequence. The decoder may use this to detect that the receiver has captured another transmission. In that case, the receiver shall stop the analysis of the current frame and start detecting a new frame. This “capture detect” feature increases the communication capacity of the system in presence of many users.

6.4.3 Mode T2: Other Device transmit: Manchester encoding

6.4.3.1 General

Manchester encoding shall be used for this mode to allow simple encoding/decoding and a narrow base-band. Each bit shall be encoded either as “10” chip sequence representing a “zero” or as “01” representing a “one”. The lower frequency shall correspond to a chip value of “0”.

6.4.3.2 Mode T2: Other Device transmit: Order of transmission of the encoded data

Each data byte shall always be transmitted with the most significant bit (MSB = most significant bit) first.

The order of multi byte fields is defined in 11.2.

6.4.3.3 Mode T2: Other Device transmit: Preamble and synchronisation pattern

The total preamble (header + synchronisation) chip sequence for this mode shall be $n \times (01) 0001110110 10010110$ with $n \geq 15$. All chips of each frame, including pre- and postamble, shall form an uninterrupted sequence. After this preamble, a frame of the format A shall follow.

NOTE 1 In Manchester coding, the chip sequence 000111 is invalid but it is used near the end of the header to allow a receiver to detect the start of a new or a stronger transmission. This applies even during reception of a weaker transmission. The capture effect allows efficient communication even in a channel where many weak transmitters from a large area might otherwise effectively block the reception of a nearer (stronger) transmitter. In addition, it allows pulsed receivers to distinguish safely between the start of a valid frame and the detection of an accidental “sync” sequence within an ongoing transmission.

NOTE 2 The data encoding is the same as used in mode S and mode R2.

7 Mode R2

7.1 Mode R2: General

The radio part of a meter shall, for all parameters, as a minimum conform to the requirements of ETSI EN 300 220 parts 1 and 2, even if some application requires extended temperature or voltage range. The specific requirements for frequency band and channel spacing are given in Table 11.

Table 11 — Mode R2, General

| Characteristic | min. | Type | max. | Unit |
|---------------------------------------------------------------------------------------------------------------------------------------------------------------------------|-------|--------|-------|------|
| Frequency band ^a | 868,0 | 868,33 | 868,6 | MHz |
| Channel spacing ^a | | 60 | | kHz |
| ^a This European Standard is optimised for the 868 MHz to 870 MHz band, although with an appropriate transmission licence, other frequency bands could be used. | | | | |

NOTE See Figure A.1 for additional information on frequency and power recommendations.

7.2 Mode R2: Transmitter

The parameters for the transmitter shall be as listed in Table 12.

Table 12 — Mode R2, Transmitter

| Characteristic | Symbol | min. | Type | max. | Unit | Note |
|-------------------------------------------------------------------------|------------------|---------------|--------------------------------------|---------------|-------|---------------------------------|
| Centre frequency (Other Device) | | | 868,330 | | MHz | |
| Centre frequency (Meter) | | | 868,030 +n × 0,06 | | MHz | |
| Frequency tolerance (Meter/Other Device) | | | 0 | ± 17 | kHz | ~20 × 10 ⁻⁶ (ppm) |
| FSK Deviation | | ± 4,8 | ± 6 | ± 7,2 | kHz | |
| Chip rate (wakeup and communications) | | | 4,8 | | kcps | |
| Chip rate tolerance (wakeup and communications) | | | 0 | ± 1,5 | % | |
| Digital bit jitter ^a | | | | ± 15 | µs | |
| Data rate (Manchester encoding) ^b | | | $f_{\text{chip}} \times \frac{1}{2}$ | | bps | |
| Preamble length including bit/byte-sync | PL | 96 | | | chips | |
| Postamble (trailer) length ^c | | 2 | | 8 | chips | |
| Response delay ^d (Other Device to Meter communication) | t_{RO} | 3 | | 50 | ms | |
| Response delay ^d (Meter to Other Device communication) | t_{RM} | 10 | | 10 000 | ms | |
| FAC Transmission delay ^{e f} | t_{TXD} | N×1 000 -1 | N×1 000 | N×1 000 +1 | ms | N=5, 7 or 13 |
| FAC Time out ^g | t_{TO} | 25 | | 30 | s | |

^a The bit jitter shall be measured at the output of the micro-controller or encoder circuit.

^b Each bit shall be coded as 2 chips (Manchester encoding).

^c The postamble (trailer) shall consists of $1 \leq n \leq 4$ "ones" i.e. the chip sequence shall be $n \times (01)$.

^d Response delay: The receiver shall be ready for the reception of a response in a time shorter than the minimum response delay, and shall be receiving at least until the maximum response delay (referred to the end of previous transmission). The response delay t_{RO} shall be used if the CI-field of received frame is 81_h, otherwise the response delay t_{RM} shall be used.

^e FAC Transmission delay: describes the duration which a Meter shall delay the first response to a received message from Other Device referred to its last transmission. This delay shall also be applied between the first response of the Meter and the next repeated response of the Meter and all following repeated responses during the Frequent Access Cycle (FAC). The reference time point shall be the end of preamble (end of sync sequence) of the Meter transmission.

^f The selected timeslot N shall be the same throughout the Frequent Access Cycle.

^g FAC Time out: is the time period between the last successful reception of a frame from the Other Device during the Frequent Access Cycle (FAC) and the moment where the repetition of the last response of the Meter shall be stopped (end of Frequent Access Cycle).

7.3 R2: Receiver

The parameters for the receiver shall be as listed in Table 13.

Table 13 — Mode R2, Receiver

| Characteristic | Class | Symbol | min. | Type | max. | Unit | Note |
|-------------------------------------------------------------------------------------------------------------------------------------------------------------------------------------------------------------------------------------------------------------------------------------------------------------------------------------------------------------------------------------------------------------------------------------------------------------------------------------------------------------------------------------------|----------------|--------------------|------|------|------|----------|--------|
| Sensitivity (BER < 10 ⁻²) or (PER < 0,8) ^a | H _R | P ₀ | -105 | -110 | | dBm | |
| Blocking performance ^b | L _R | | 3 | | | Category | |
| Blocking performance ^{b c} | M _R | | 2 | | | Category | |
| Blocking performance ^{b c d} | H _R | | 2 | | | Category | |
| Acceptable chip rate range | | f _{chip} | 4,7 | 4,8 | 4,9 | kcps | ~ ±2 % |
| Acceptable chip rate variation during header and frame | | Df _{chip} | | 0 | ±0,2 | % | |
| ^a At a frame size of 20 bytes. ^b Receiver category shall be according to ETSI EN 300 220-1 V2.4.1:2012, 4.1.1. ^c Additional requirement for Class M _R and Class H _R receivers: The equipment shall meet the immunity requirements as specified in ETSI EN 301 489-1, V1.9.2:2011, 9.2. ^d Additional requirement for Class H _R receivers: Adjacent band selectivity shall be > 40 dB when measured according to ETSI EN 300 220-1, V2.4.1:2012, 8.3. | | | | | | | |

7.4 Mode R2: Data encoding

7.4.1 Mode R2: Manchester encoding

Manchester encoding shall be used for this mode to allow simple encoding/decoding and a narrow base-band. Each bit shall be encoded either as a “10” chip sequence representing a “zero” or as a “01” representing a “one”. The lower frequency corresponds to a chip value of “0”.

7.4.2 Mode R2: Order of transmission of the encoded data

Each data byte shall be transmitted with the most significant bit first.

The order of multi byte fields is defined in 11.2.

7.4.3 Mode R2: Preamble and synchronisation pattern

The total preamble (header + synchronisation) chip sequence for this mode shall be n × (01) 0001110110 10010110 with n ≥ 39. All chips of each frame shall form an uninterrupted chip sequence. After this preamble, a frame of the format A shall follow.

NOTE 1 In Manchester coding, the chip sequence 000111 is invalid, but it is used near the end of the header to allow a receiver to detect the start of a new or a stronger transmission. This applies even during reception of a weaker transmission. The capture effect allows efficient communication even in a channel where many weak transmitters from a large area might otherwise effectively block the reception of a nearer (stronger) transmitter. In addition, it allows pulsed receivers to distinguish safely between the start of a valid frame and the detection of an accidental “sync” sequence within an ongoing transmission.

NOTE 2 The data encoding is the same as used in mode S and mode T2.

8 Mode C

8.1 Mode C: General

The radio part of a meter shall, for all parameters, as a minimum conform to the requirements of ETSI EN 300 220 parts 1 and 2, even if some applications require extended temperature or voltage range. The specific requirements for frequency bands are given in Table 14.

Table 14 — Mode C, General

| Characteristic | Mode | min. | Typ | max. | Unit |
|----------------------------------------------------|--------|-------|---------|--------|------|
| Frequency band: Meter to Other Device ^a | C1, C2 | 868,7 | 868,95 | 869,2 | MHz |
| Frequency band: Other Device to Meter ^a | C2 | 869,4 | 869,525 | 869,65 | MHz |

^a This European Standard is optimised for the 868 MHz to 870 MHz band, although with an appropriate transmission licence, other frequency bands could be used.

NOTE See Figure A.1 for additional information on frequency and power recommendations.

8.2 Mode C: Transmitter

The parameters for the transmitter shall be as listed in Table 15.

Table 15 — Mode C, Transmitter

| Characteristic | Mode | Symbol | min. | Type | max. | Unit | Note |
|-----------------------------------------------------------------------------------------|--------|-----------------------|---------|-------------------|---------|-------|---------|
| Centre frequency (Meter to Other Device) | C1, C2 | | 868,928 | 868,950 | 868,972 | MHz | ±25 ppm |
| Centre frequency (Other Device to Meter) | C2 | | 869,503 | 869,525 | 869,547 | MHz | ±25 ppm |
| FSK Deviation ^a (Meter to Other Device) | C1, C2 | | ± 33,75 | ± 45 | ± 56,25 | kHz | |
| GFSK Deviation ^a (Other Device to Meter) | C2 | | ± 18,75 | ± 25 | ± 31,25 | kHz | |
| GFSK relative bandwidth | C2 | BT | | 0,5 | | | |
| Chip rate (Meter to Other Device) | C1, C2 | f_{chip} | | 100 | | kcps | |
| Chip rate (Other Device to Meter) | C2 | f_{chip} | | 50 | | kcps | |
| Chip rate tolerance | C1, C2 | | | | ±100 | ppm | |
| Data rate ^b | C1, C2 | | | f_{chip} | | bps | |
| Preamble length | C1, C2 | PL | 32 | | 32 | chips | |
| Synchronisation length | C1, C2 | SL | 32 | | 32 | chips | |
| Fast response delay (default) ^{c d e} (Other Device to Meter communication) | C2 | t_{RO} | 99,5 | 100 | 100,5 | ms | |
| Slow response delay ^{c d e} (Other Device to Meter communication) | C2 | $t_{\text{RO_slow}}$ | 999,5 | 1 000 | 1 000,5 | ms | |

| Characteristic | Mode | Symbol | min. | Type | max. | Unit | Note |
|---------------------------------------------------------------------------------------|------|----------------|-------------------------|-------------------|-------------------------|------|--------------|
| Fast response delay (default) ^{c d} (Meter to Other Device communication) | C2 | t_{RM} | 99,5 | 100 | 100,5 | ms | |
| Slow response delay ^{c d} (Meter to Other Device communication) | C2 | t_{RM_slow} | 999,5 | 1 000 | 1 000,5 | ms | |
| FAC Transmission delay ^{f g} | C2 | t_{TxD} | $N \times 1\,000 - 0,5$ | $N \times 1\,000$ | $N \times 1\,000 + 0,5$ | ms | N = 2,3 or 5 |
| FAC Time out ^h | C2 | t_{TO} | 25 | | 30 | s | |

^a 75 % to 125 % of nominal deviation measured in centre of chip (frequency vs. time eye opening) transmitting a 9 bit pseudo-random (PN9) sequence, min./max. based on the root-mean-square (rms) error value.

^b All bits are NRZ coded.

^c After receiving a frame the responding unit shall start the transmission of preamble after the specified response delay. The response delay is measured from the reception time of the last bit of the frame. For timing diagrams see Annex E.

^d The use of slow or fast response delay is specified in the "Communication Control Field" of the Extended Link Layer – refer to 12.2.2. For timing diagrams see Annex E. If an Extended Link Layer is not included in the frame, the default response delay shall be used.

^e If the frame is repeated (specified in the "Communication Control Field" of the Extended Link Layer – refer to 12.2.2) the Other Device shall instead use a shorter response delay (t_{RR} or t_{RR_slow}) being 85 ms shorter than the corresponding t_{RO} or t_{RO_slow} . This enables bi-directional communication to be repeated without loss of communication speed. The frame from meter to Other Device shall be repeated with a delay less than 5 ms (t_{DRFE}). For timing diagrams see Annex E.

^f FAC Transmission delay: This delay shall be applied between the first response of the meter and the next repeated response of the meter and all following repeated responses during the Frequent Access Cycle (FAC). The reference time point shall be the end of preamble (end of sync sequence) of the meter transmission. For timing diagrams see Annex E.

^g The selected timeslot N shall be the same throughout the Frequent Access Cycle.

^h FAC Time out: This is the time period between the last successful reception of a frame from the Other Device during the Frequent Access Cycle (FAC) and the moment where the repetition of the last response of the meter shall be stopped (end of Frequent Access Cycle).

8.3 Mode C: Receiver

The parameters for the receiver shall be as listed in Table 16.

Table 16 — Mode C, Receiver

| Characteristic | Class | Symbol | min. | Type | max. | Unit |
|-------------------------------------------------------------------------------------------------------------------------------------------------------------------------------------------------------------------------------------------------------------------------------------------------------------------------------------------------------------------------------------------------------------------------------------------------------------------------------------------------------------------------------------------------|----------------|----------------|------|------|------|----------|
| Sensitivity (BER < 10 ⁻²) or (PER < 0,8) (Other Device) ^a | H _R | P ₀ | -100 | -105 | | dBm |
| Sensitivity (BER < 10 ⁻²) or (PER < 0,8) (Meter) ^a | H _R | P ₀ | -95 | | | dBm |
| Blocking performance ^b | L _R | | 3 | | | Category |
| Blocking performance ^{b c} | M _R | | 2 | | | Category |
| Blocking performance ^{b c d} | H _R | | 2 | | | Category |
| ^a At a frame size of 20 bytes. ^b Receiver category according to ETSI EN 300 220-1, V2.4.1:2012, 4.1.1. ^c Additional requirement for Class MR and Class HR receivers: The equipment shall meet the immunity requirements as specified in ETSI EN 301 489-1, V1.9.2:2011, 9.2 and in ETSI EN 301 489-3, V1.4.1:2002. ^d Additional requirement for Class H _R receivers: Adjacent band selectivity shall be > 40 dB when measured according to ETSI EN 300 220-1, V2.4.1:2012, 8.3. | | | | | | |

8.4 Mode C: Data encoding

8.4.1 General

All communication from Meter to Other Device is transmitted as FSK modulated data. All communication from Other Device to Meter is transmitted as GFSK modulated data. All communication is NRZ-encoded, with the low frequency corresponding to a binary '0'.

Each data byte shall be transmitted with the most significant bit first.

The order of multi byte fields is defined in 11.2.

8.4.2 Mode C: Preamble and synchronisation pattern

All communication shall be preceded by either

(A) $n \times (01) 0101010000111101 0101010011001101$, or

(B) $n \times (01) 0101010000111101 0101010000111101$, with $n = 16$.

The first 16 chips of the synchword are equal to preamble + synchword of mode T. This makes it possible to implement one decoder being able to decode both frames of mode T and frames of mode C. If the frame is of mode C, the next 6 chips will form the pattern "010101". The decoder may use this to detect that the received frame is not of mode T since the pattern "010101" will never occur inside the "3 out of 6" encoded chip sequence used in mode T. The last 8 chips decide about the selected frame format. If the pattern of the last 8 chips equals to "11001101" the frame format A follows. If the pattern of the last 8 chips equals to "00111101" the frame format B follows (refer to 11.4).

The decoder may optionally detect that the receiver has captured another transmission, by detecting a new preamble and synchronisation sequence in conjunction with an abrupt increase in the received signal strength. In that case, the receiver shall stop the analysis of the current frame and start detecting a new frame. This "capture detect" feature increases the communication capacity of the system in presence of many users.

9 Mode N

9.1 Mode N: General

The radio part of a meter shall, for all parameters, as a minimum conform to the requirements of ETSI EN 300 220 parts 1 and 2 even if some applications require extended temperature or voltage range. The specific requirements for frequency band, duty channel spacing and cycle are given in Table 17.

Table 17 — Mode N, General

| Characteristic | min. | Type | max. | Unit |
|-----------------------------|---------|------------|---------|------|
| Frequency band ^a | 169,400 | | 169,475 | MHz |
| Channel spacing | | 12,5/25/50 | | kHz |
| Transmitter duty cycle | | | 10 | % |

^a This European Standard is optimised for the 169 MHz band, although with an appropriate transmission licence, other frequency bands could be used.

9.2 Mode N: Physical link parameters

The sub modes shall be allocated to the channels and frequencies as given in Table 18.

Table 18 — Mode N, Frequencies

| Submode | Channel ^b | Centre frequency [MHz] | Channel spacing [kHz] | GFSK [kbps] | 4 GFSK [kbps] | Frequency tolerance [± kHz] |
|----------|----------------------|------------------------|-----------------------|-------------|---------------|-----------------------------|
| N1a, N2a | 1a ^c | 169,406250 | 12,5 | 4,8 | | 1,5 |
| N1b, N2b | 1b | 169,418750 | 12,5 | 4,8 | | 1,5 |
| N1c, N2c | 2a | 169,431250 | 12,5 | 2,4 | | 2,0 |
| N1d, N2d | 2b | 169,443750 | 12,5 | 2,4 | | 2,0 |
| N1e, N2e | 3a | 169,456250 | 12,5 | 4,8 | | 1,5 |
| N1f, N2f | 3b ^c | 169,468750 | 12,5 | 4,8 | | 1,5 |
| N2g | 0 ^d | 169,437500 | 50 | | 19,2 | 2,5 |
| a | 1 | 169,412500 | 25 | | | |
| a | 2 | 169,437500 | 25 | | | |
| a | 3 | 169,462500 | 25 | | | |

^a These channels are optional and reserved for future use or national specific use.
^b The channel designation is according to EU Commission Decision 2005/928/EC.
^c These channels are preferred when meter transmission needs to be retransmitted.
^d This channel may be used for multi-hop retransmission of meter data as specified in EN 13757-5. The duty cycle for transmission from the meter shall be limited to 0,02 % in this channel.

The modulation and timing shall be as given in Table 19

Table 19 — Mode N, Modulation and timing

| Characteristic | Data rate | Symbol | min. | Type | max. | Unit | Note |
|---------------------------------------------------------------|-----------------------------------|----------------------|-------------------------------|------------------------------|-------------------------------|-----------------|--------------------------------------------|
| GFSK Modulation (modulation index 2,0) | 2,4 kbps | | ± 1,68 | ± 2,4 | ± 3,12 | kHz | 70-130 % of nominal deviation ^a |
| GFSK Modulation (modulation index 1,0) | 4,8 kbps | | ± 1,68 | ± 2,4 | ± 3,12 | kHz | 70-130 % of nominal deviation ^a |
| 4GFSK Modulation (modulation index 0,5) | 19,2 kbps | | | -7,2, -2,4, +2,4, +7,2 | | kHz | |
| 4GFSK peak modulation | 19,2 kbps | | ± 5,04 | | ± 9,36 | kHz | 70-130 % of nominal deviation ^a |
| GFSK/4GFSK relative bandwidth | All | BT | | 0,5 | | | |
| Bit/symbol rate tolerance | All | | | | ± 100 | ppm | |
| Preamble length | All | PL | 16 | | 16 | bits or symbols | |
| Synchronisation length | All | SL | 16 | | 16 | bits or symbols | |
| Postamble (trailer) length | All | | | 0 | | bits or symbols | |
| Fast response delay ^b (Other Device to Meter) | All | t _{RO} | 99,5 | 100 | 100,5 | ms | |
| Slow response delay ^b (Other Device to Meter) | 2,4 kbps 4,8 kbps 19,2 kbps | t _{RO_slow} | 2 099,5 1 099,5 1 099,5 | | 2 100,5 1 100,5 1 100,5 | ms | |
| FAC transmission delay ^c _d (N2a to N2f) | 2,4 kbps 4,8 kbps | t _{TxD} | N×1 000 -0,5 | N×1 000 | N×1 000+ 0,5 | ms | N=5,7 or 13 |
| FAC transmission delay ^c _d (N2g only) | 19,2 kbps | t _{TxD} | N×1 000 -0,5 | N×1 000 | N×1 000+ 0,5 | ms | N= 2,3 or 5 |
| FAC time out ^e | All | t _{TO} | 25 | | 30 | s | |

- ^a Measured in centre of outer symbol (frequency vs. time eye opening) transmitting PN9 sequence, min./max. based on rms error value.
- ^b The transmitter shall start transmitting the preamble within this time delay after last bit of received frame. The use of slow or fast response delay is specified in the "Communication Control Field" of the Extended Link Layer – refer to 12.2.2.3. For timing diagrams see Annex E. If an Extended Link Layer is not included in the frame, the default response delay shall be used.
- ^c FAC Transmission delay: describes the duration which a Meter shall delay the first response to a received message from an Other Device referred to its last transmission. This delay shall also be applied between the first response of the Meter and the next repeated response of the Meter and all following repeated responses during the Frequent Access Cycle (FAC). The reference time point shall be the end of preamble (end of sync sequence) of the Meter transmission.
- ^d The selected timeslot N shall be the same throughout the Frequent Access Cycle.
- ^e FAC Time out: is the time period between the last successful reception of a frame from the Other Device during the Frequent Access Cycle (FAC) and the moment where the repetition of the last response of the Meter shall be stopped (end of Frequent Access Cycle).

9.3 Mode N: Receiver sensitivity

The receiver sensitivity and blocking performance shall be as given in Table 20.

Table 20 — Mode N, Receiver

| Characteristic | Class | Symbol | min. | Type | max. | Unit | Note |
|--------------------------------------------------------------------------------------------------------------------------------------------------------------------------------------------------------------------------------------------------------------------------------------------------------------------------------------------------------------------------------------------------------------------------------------------------------------------------------------------------------------------------------------|----------------|----------------|------|------|------|----------|-----------|
| Sensitivity (BER $<10^{-2}$) or (PER $<0,8$) ^a (Other Device /Meter) GFSK | H _R | P _O | -115 | -123 | | dBm | 2,4 kbps |
| Sensitivity (BER $<10^{-2}$) or (PER $<0,8$) ^a (Other Device /Meter) GFSK | H _R | P _O | -112 | -120 | | dBm | 4,8 kbps |
| Sensitivity (BER $<10^{-2}$) or (PER $<0,8$) ^a (Other Device /Meter) 4GFSK | H _R | P _O | -104 | -107 | | dBm | 19,2 kbps |
| Blocking Performance ^b | L _R | | 3 | | | Category | |
| Blocking Performance ^{b c} | M _R | | 2 | | | Category | |
| Blocking Performance ^{b c d} | H _R | | 2 | | | Category | |
| ^a At a frame size of 20 bytes. ^b Receiver category according to ETSI EN 300 220-1, V2.4.1:2012; 4.1.1. ^c Additional requirements for Class M _R and Class H _R receivers: The equipment shall meet the immunity requirements as specified in ETSI EN 301 489-1, V1.9.2:2011, 9.2. ^d Additional requirement for Class H _R receivers: Adjacent band selectivity shall be > 40 dB when measured according to ETSI EN 300 220-1, V2.4.1:2012, 8.3. | | | | | | | |

9.4 Mode N: Data encoding

9.4.1 Mode N: General

Data transmitted using GFSK modulation shall be NRZ encoded, with the low frequency corresponding to a binary "0".

Data transmitted using 4GFSK modulation shall be NRZ encoded, with the lowest frequency corresponding to binary "01" (symbol A), the second frequency corresponding to binary "00" (B), the third frequency corresponding to binary "10" (C) and the highest frequency corresponding to binary "11" (D).

Each data byte shall be transmitted with the most significant bit first.

The order of multi byte fields is defined in 11.2.

9.4.2 Mode N: Preamble and synchronisation pattern

All transmissions using GFSK shall, where $n = 8$, be preceded by either;

- $n \times (01) 11110110 10001101$ (frame format A) or,
- $n \times (01) 11110110 01110010$, (frame format B).

All transmissions using 4GFSK shall, where $n = 8$, be preceded by either;

- $n \times (AD) DDDDADDA DAAADDAD$ (frame format A) or,
- $n \times (AD) DDDDADDA ADDDAADA$ (frame format B).

NOTE The first pattern is equivalent to, the bit pattern $n \times (0111) 111111101111101 1101010111110111$ and the second pattern is equivalent to the bit pattern $n \times (0111) 111111101111101 0111111101011101$.

All chips of each frame, including pre- and postamble, shall form an uninterrupted sequence.

The decoder may optionally detect that the receiver has captured another transmission, by detecting a new preamble and synchronisation pattern in conjunction with an abrupt increase in the received signal strength. In that case, the receiver shall stop the analysis of the current frame and start detecting a new frame. This "capture detect" feature increases the communication capacity of the system in presence of many devices.

10 Mode F

10.1 Mode F: General

The radio part of a meter shall, for all parameters, as a minimum conform to the requirements of ETSI EN 300 220 parts 1 and 2, even if some applications require extended temperature or voltage range. The specific requirements for frequency band duty cycle are given in Table 21.

Table 21 — Mode F, General

| Characteristic | min. | Typ | max. | Unit |
|----------------------------------------------------------------------------------------------------------------------------------------------------------------|---------|---------|---------|------|
| Frequency band ^a | 433,050 | 433,820 | 434,790 | MHz |
| Transmitter duty cycle | | | 10 | % |
| ^a This European Standard is optimised for the 433 MHz band, although with an appropriate transmission licence, other frequency bands could be used. | | | | |

10.2 Mode F: Physical link parameters

The transmitter parameters shall be as given in Table 22.

Table 22 — Mode F, Transmitter parameters

| Characteristic | Symbol | Mode | Min | Type | Max | Unit | Note |
|---------------------------------------------------------------|----------------|----------|-----------|-----------|-----------|------|--------|
| Centre frequency | | All | 433,813 | 433,82 | 433,827 | MHz | 16 ppm |
| FSK Deviation ^a | | F2, F2-m | $\pm 4,8$ | $\pm 5,5$ | $\pm 7,0$ | kHz | |
| Data rate | | F2, F2-m | | 2,4 | | kcps | |
| Data rate tolerance | | All | | | ± 100 | ppm | |
| Response delay ^b (Meter to Other Device) | t_{RM} | F2-m | 3 | 50 | 4 000 | ms | |
| Fast response delay ^{c d} (Other Device to Meter) | t_{RO} | F2 | 99,5 | 100 | 100,5 | ms | |
| Slow response delay ^{c d} | t_{RO_slow} | F2 | 999,5 | 1 000 | 1 000,5 | ms | |

| Characteristic | Symbol | Mode | Min | Type | Max | Unit | Note |
|---------------------------------------|-----------|------|-------------------------|-------------------|-------------------------|------|--------------|
| (Other Device to Meter) | | | | | | | |
| FAC transmission delay ^{e f} | t_{TxD} | F2 | $N \times 1\,000 - 0,5$ | $N \times 1\,000$ | $N \times 1\,000 + 0,5$ | ms | N= 5,7 or 13 |
| FAC time out ^g | t_{TO} | F2 | 25 | | 30 | s | |

^a 75 % to 125 % of nominal deviation measured in centre of chip (frequency vs. time eye opening) transmitting a 9 bit pseudo-random (PN9) sequence, min./max. based on the root-mean-square (rms) error value selected.

^b The time a Meter shall delay the response to a received message from an Other Device.

^c After receiving a frame the responding unit shall start the transmission of preamble after the specified response delay. The response delay is measured from the reception time of the last bit of the frame. For timing diagrams see Annex E.

^d The use of slow or fast response delay is specified in the "Communication Control Field" of the Extended Link Layer – refer to 12.2.2.3. For timing diagrams see Annex E. If an Extended Link Layer is not included in the frame, the default response delay shall be used.

^e FAC Transmission delay: This delay shall be applied between the first response of the meter and the next repeated response of the meter and all following repeated responses during the Frequent Access Cycle (FAC). The reference time point shall be the end of preamble (end of sync sequence) of the meter transmission. For timing diagrams see Annex E.

^f The selected timeslot N shall be the same throughout the Frequent Access Cycle.

^g FAC Time out: This is the time period between the last successful reception of a frame from the Other Device during the Frequent Access Cycle (FAC) and the moment where the repetition of the last response of the Meter shall be stopped (end of Frequent Access Cycle).
 If the frame is repeated (specified in the "Communication Control Field" of the Extended Link Layer – refer to 12.2.2) the Other Device shall instead use a shorter response delay (t_{RR} or t_{RR_slow}) being 85 ms shorter than the corresponding t_{RO} or t_{RO_slow} . This enables bi-directional communication to be repeated without loss of communication speed. The frame from Meter to Other Device shall be repeated with a delay less than 5 ms (t_{DRF}). For timing diagrams see Annex E.

10.3 Mode F: Receiver sensitivity

The receiver sensitivity and blocking performance shall be as given in Table 23.

Table 23 — Mode F, Receiver

| Characteristic | Class | Symbol | min. | Type | max. | Unit | Note |
|-------------------------------------------------------------------------------|----------------|----------------|------|------|------|----------|----------|
| Sensitivity (BER 10^{-2}) or (PER $0,8$) ^a | H _R | P _O | -115 | -117 | | dBm | 2,4 kbps |
| Blocking performance ^b | L _R | | 3 | | | Category | |
| Blocking performance ^{b c} | M _R | | 2 | | | Category | |
| Blocking performance ^{b c d} | H _R | | 2 | | | Category | |

^a At a frame size of 20 bytes.

^b Receiver category according to ETSI EN 300 220-1, V2.4.1:2012; 4.1.1.

^c Additional requirements for Class M_R and Class H_R receivers: The equipment shall meet the immunity requirements as specified in ETSI EN 301 489-1, V1.9.2:2011, 9.2.

^d Additional requirement for Class H_R receivers: Adjacent band selectivity shall be > 40 dB when measured according to ETSI EN 300 220-1, V2.4.1:2012, 8.3.

10.4 Mode F: Data encoding

10.4.1 Mode F: General

Data transmitted using FSK modulation shall be NRZ-encoded. The low frequency shall correspond to a binary "0". Each data byte shall be transmitted with the most significant bit first.

The order of multi byte fields is defined in 11.2.

10.4.2 Mode F: Preamble and synchronisation pattern

All transmitted data shall be preceded by a preamble. It shall for Data Link Layer format A be; $n \times (01) 1111 0110 1000 1101$, with $n \geq 39$. It shall for Data Link Layer format B be; $n \times (01) 1111 0110 0111 0010$, with $n \geq 39$.

11 Data Link Layer

11.1 General

The Data Link Layer follows immediately after the preamble and synchronisation pattern (Medium Access Layer). This standard supports the two different frame formats A and B for the Data Link Layer. The frame format shall be detected by the preamble and synchronisation pattern (refer to the description of the respective modes). The frames are divided into blocks. In both formats, the first block has a fixed length of 10 bytes and contains the link layer, which consists of the frame length (L-field), the control information (C-field), and the sender address (Link Layer Address). The second block starts with the CI-field which is used to declare the structure of the following data. The following data consist of one or several layers before the application data (if any). This can be a collapsed Extended Data Link/Network Layer and an application data header referred to as the Transport Layer, a Network Layer (see EN 13757-5), or an extension to the link layer (Extended Link Layer), as described in the following. The CI-field also defines the application protocol (if any).

The availability of multiple frame formats does not imply that a Device, be it a Meter or an Other Device, shall concurrently support both frame formats. A Device may implement both frame formats. A Meter should, once installed not change its frame format.

For modes where both frame formats are supported, the Other Device should, while performing installation of a Meter, detect both frame formats. The Other Device could during subsequent communications synchronise only on the Meters known frame format.

11.2 Order of multi byte fields

Any byte sequence of multi byte fields, before the first CI-field, shall be transferred with the low byte first. The byte sequence of multi byte fields after CI-fields of 80_h , $8A_h$, $8B_h$, $8C_h$, $8D_h$, $8E_h$ and $8F_h$ (see 12.2 and 12.3) shall be as well transferred with the low byte first. The byte sequence of other multi byte fields is not defined in this document. Multi byte fields after the first CI-field shall be transferred as specified in the implemented layers, i.e. according to EN 13757-1 and EN 13757-3 for the application layer.

The byte sequence of the CRC shall be transferred with the high byte first.

11.3 Frame format A

11.3.1 General

Frame format A complies to EN 60870-5-1 with the format Class FT3. The start bytes 05_h 64_h are replaced by the preamble chip sequence as described in the respective mode. The format of the different blocks in the frame is specified below.

11.3.2 First block

The format of the first block shall be as shown in Figure 2.

| L-field | C-field | M-field | A-field | CRC-field |
|---------|---------|---------|---------|-----------|
| 1 byte | 1 byte | 2 bytes | 6 bytes | 2 bytes |

Figure 2 — First block format

11.3.3 Second block

The format of the second block shall be as shown in Figure 3.

| CI-field | Data-field | CRC-field |
|----------|----------------------------------------------------------------------|-----------|
| 1 byte | 15 or if it is the last block $((L-9) \text{ modulo } 16) - 1$ bytes | 2 bytes |

Figure 3 — Second block format

11.3.4 Optional block(s)

The format of any subsequent optional block shall be as shown in Figure 4.

| Data-field | CRC-field |
|------------------------------------------------------------------|-----------|
| 16 or if it is the last block $((L-9) \text{ modulo } 16)$ bytes | 2 bytes |

Figure 4 — Optional block(s) format

11.4 Frame format B

11.4.1 General

The link layer check of frame format B is performed on a maximum of 128 bytes including the CRC-field. Frames with a length of up to 128 bytes, including CRC- and L-field, contain a single CRC-field covering both first block and second block. Frames with a length between 131 bytes and 256 bytes (maximum length) contain two CRC-fields where the second CRC-field covers the optional block. The format of the different blocks in the frame is specified below.

11.4.2 First block

The format of the first block shall be as shown in Figure 5.

| L-field | C-field | M-field | A-field |
|---------|---------|---------|---------|
| 1 byte | 1 byte | 2 bytes | 6 bytes |

Figure 5 — First block format

11.4.3 Second block

The format of the second block shall be as shown in Figure 6.

| CI-field | Data-field | CRC-field |
|----------|---------------------------------------------|-----------|
| 1 byte | 115 or if it is the last block (L-12) bytes | 2 bytes |

Figure 6 — Second block format

11.4.4 Optional block

The format of any subsequent block shall be as shown in Figure 7.

| Data-field | CRC-field |
|---------------|-----------|
| (L-129) bytes | 2 bytes |

Figure 7 — Optional block format

11.5 Field definitions

11.5.1 General

The fields as defined in EN 60870-5-1 (L-field) and EN 60870-5-2 (C-field, M-field and A-field) are specified in the subsequent subclauses. The A-field of EN 60870-5-2 corresponds to the concatenation of the M-field and the A-field presented here.

11.5.2 Multi byte fields

Multi byte fields shall be handled as specified in 11.2.

11.5.3 Length field (L-Field)

Frame format A:

The first byte of the first block is the length field. The field specifies the number of subsequent user data bytes including the control and address bytes and excluding the CRC bytes. If $((L-9) \text{ MOD } 16)$ is not zero, then the last block shall contain $((L-9) \text{ MOD } 16)$ data bytes + 2 CRC bytes. All the other blocks except the first block shall always contain 16 data bytes + 2 CRC bytes.

Frame format B:

The first byte of the first block is the length field. The field specifies the number of all subsequent bytes including all CRC bytes.

11.5.4 Control field (C-Field)

The second byte of the first block is the C-field. It specifies the frame type.

The general format of the C-field, bit by bit is as shown in Figure 8.

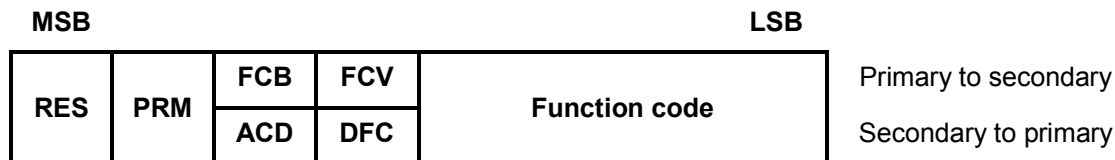

Figure 8 — C-field data format

RES – bit shall always be '0'.

PRM – '1' message from primary (initiating) station;

'0' message from secondary (responding) station.

FCB, FCV and ACD, DFC-bit coding shall be used according to the rules in EN 60870-5-2.

The Function codes as given in Table 24 and Table 25 may be used. Primary station and secondary station are defined in EN 60870-5-2.

Table 24 — Function codes of the C-field in messages sent from primary stations

| Function code | Symbolic name | Direction | Function | Confirmation by | Support by meter |
|----------------|-----------------------------|------------|------------------------------------------------------------------------------------------------------------------------------------------------------------------------------------------------------------------------------|--------------------------|--------------------------------------------|
| 0 _h | SND-NKE ^{a, b} | To meter | Link reset after communication; It clears the FCB and finishes the Frequent Access Cycle. It also signals an applicable radio link to a Meter which has sent an installation message (SND-NKE contains no application data). | — | Mandatory for S2, T2, C2, R2, N2 and F2 |
| 3 _h | SND-UD/SND-UD2 ^c | To meter | Send a command (Send User Data) | ACK/ RSP-UD ^c | Mandatory for S2, T2, C2 and R2, N2 and F2 |
| 4 _h | SND-NR ^d | From meter | Send unsolicited/periodical application data without request (Send/No Reply) | — | Mandatory for S1, T1, C1 and N1 |
| 6 _h | SND-IR | From meter | Send manually initiated installation data (Send Installation Request) | CNF-IR | Optional |
| 7 _h | ACC-NR | From meter | Send unsolicited/periodical message to provide the opportunity of access to the Meter (contains no application data) | — | Optional |
| 8 _h | ACC-DMD | From meter | Access demand from Meter to Other Device. This message requests an access to the Meter (contains no application data) | ACK | Optional |
| A _h | REQ-UD1 ^e | To meter | Alarm request, (Request User Data Class 1) (contains no application data) | ACK/RSP-UD ^e | Mandatory for S2, T2, C2, R2, N2 and F2 |
| B _h | REQ-UD2 | To meter | Data request (Request User Data Class 2) (contains no application data) | RSP-UD | Mandatory for S2, T2, C2, R2, N2 and F2 |

| Function code | Symbolic name | Direction | Function | Confirmation by | Support by meter |
|---------------|---------------|-----------|-------------------------------------------------------------------------------------------------------------------------------------------------------------------------------------------------------------------------------------------------------------------------------------------------------------------------------------------------------------------------------------------------------------------------------------------------------------------------------------------------------------------------------------------------------------------------------------------------------------------------------------------------------------------------------|-----------------|------------------|
| a | | | After a FAC-Timeout happens (refer to 11.6.3.3) the FCB shall be cleared automatically. | | |
| b | | | Named SND-NKE in EN 13757-2. | | |
| c | | | The SND-UD is used together with a valid FCB (C-field is 53 _h or 73 _h) and shall be responded with an ACK message. If the meter receives Function code 3 _h with a cleared FCV-bit (C-field is 43 _h), the meter shall assume the reception of a SND-UD with a subsequent REQ-UD2. Therefore it shall respond with the corresponding RSP-UD instead of an ACK. This message is called SND-UD2. The support of the SND-UD2 is optional. If the meter does not support the message SND-UD2, it shall respond with an ACK instead, and discard the message. The SND-UD2 is not applicable for fragmented messages. See also Annex E. | | |
| d | | | The meter may use a Frequent Transmit Cycle (FTC), i.e. retransmitting the same message a limited number of times, until the Other Device responds. The Other Device should use SND-NKE to respond and the meter should then finish the FTC. For example, for daily readings the meter may retransmit the message every 6 h, unless the Other Device responds with an SND-NKE, after which the meter would transmit only after 24 h. | | |
| e | | | If the meter has no support for alarm data, it has at least to respond with an ACK. | | |

Table 25 — Function codes of C-field in messages sent from secondary stations

| Function code | Symbolic name | Direction | Function | Initiated by | Support by meter |
|----------------|---------------|-----------------|-------------------------------------------------------------------------------------------------------------------------------------------------------------------------------------------------------|---------------------|-----------------------------------------|
| 0 _h | ACK | Both directions | Acknowledge the reception of an ACC-DMD or SND-UD (acknowledgement of transmission only). It shall also be used as a response to an REQ-UD1 when no alert happened (contains no application data). | SND-UD/ ACC-DMD | Mandatory for S2, T2, C2, R2, N2 and F2 |
| 6 _h | CNF-IR | To meter | Confirms the successful registration (installation) of meter to service tool (contains no application data). | SND-IR | Optional |
| 8 _h | RSP-UD | From meter | Response of application data after a request from the primary station (response of user data) | REQ-UD1/ REQ-UD2 | Mandatory for S2, T2, C2,R2, N2 and F2 |

11.5.5 Manufacturer ID (M-field)

The third and the fourth byte of the first block shall contain a unique User/Manufacturer ID of the sender. The 15 least significant bits of these two bytes shall be formed from a three letter ISO/IEC 646 code (A...Z) as specified in 5.6 of EN 13757-3:2013. See Annex B for administration of these three letter codes.

If the most significant bit of these two bytes User/Manufacturer ID is equal to zero, then the address A shall be a unique (hard coded) manufacturer meter address of 6 bytes. Each manufacturer is responsible for the worldwide uniqueness of these 6 bytes. Any type of coding or numbering, including type/version/date may be used as long as the ID is unique.

If the most significant bit of this two-byte User/Manufacturer ID is different from zero, then the 6 byte address shall be unique at least within the maximum transmission range of the system (soft address). This address is usually assigned to the device at installation time. As long as these unique address requirements are fulfilled, the remaining bytes may be used for user specific purposes.

NOTE The address is used in the back office to identify the meter independently of its communication interface. Therefore the manufacturer needs to assure a uniqueness of the addresses not only for wireless meters but for all produced meters.

11.5.6 Address (A-field)

This address field A contains, in deviation to EN 60870-5-2, always the address of the sender. At uplink - the address of a Meter with integrated radio module or the address of a radio adapter supporting a Meter without a radio module and at downlink the address of the Other Device. The address of the receiver (required for the downlink) shall follow in the extended Data Link Layer, see 12.2, or in the Transport Layer, see 12.3. The address shall be unique, see 11.5.5. Each User/Manufacturer shall guarantee that this address is unique. If this protocol is used together with the Transport Layer or the Application Layer of EN 13757-3 then the following Address structure shall be applied: the A-field shall be generated as a concatenation of the 'Identification number', 'Version number' and 'Device type information' as specified in 5.5, 5.7 and 5.8 of EN 13757-3:2013, refer to examples in Annex C.

NOTE If the meter address differs from the sender address, the meter address will be transmitted after the CI-field using a long Transport Layer; see 12.3 and EN 13757-3.

11.5.7 Cyclic redundancy check (CRC-field)

The CRC shall be computed over the information from the previous block, and shall be generated according to FT3 of EN 60870-5-1. The formula is:

The CRC polynomial is: $x^{16} + x^{13} + x^{12} + x^{11} + x^{10} + x^8 + x^6 + x^5 + x^2 + 1$

The initial value is 0.

The final CRC is complemented.

11.5.8 Control information field (CI-field)

The first byte of the second block is the CI-field. The CI-field specifies the type of protocol and thus the nature of the information that follows. The CI-field may declare an Application Layer, a Transport Layer, a Network Layer or an Extended Link Layer. The CI-field is defined in 12.1.

11.6 Timing

11.6.1 Timing for installation messages

A Meter may support additional installation messages. The installation messages shall be started only with a manual event (e.g. by pressing a button). The transmission of installation messages shall start immediately after this event.

For an efficient commissioning the installation messages (SND-IR) shall be repeated at least 6 t with an interval of 30 to 60 s. The transmission of installation messages shall stop no later than 60 min after the manual start event.

If the Other Device receives an installation message (SND-IR) and registers this Meter finally for permanent reception, it should respond with a Confirm Installation Message (CNF-IR) to signal the successful registration to the Meter itself and to an optionally service tool. If the Meter receives this message, it may stop the repetition of installation messages. The service tool may use this message to give a feedback to the service technician, about the successful meter installation.

If the Other Device receives an installation message (SND-IR) it may generate a feedback message (SND-NKE) to a service tool. To avoid collisions with a second Other Device the transmission of the feedback message (SND-NKE) shall be randomly delayed between 5 s and 25 s after the reception of the Meter installation message. The transmission of the feedback message (SND-NKE) is independent from the transmission or reception of a Confirm Installation Message (CNF-IR). Refer to Annex E.

11.6.2 Synchronous transmissions of meter messages

In order to enable battery efficient Other Device's (data concentrators, repeaters, etc) that only switch on their receivers for predicted short time windows, the Meter should follow a strict transmission time scheme. The use of the synchronous transmission scheme is optional.

The Meter shall transmit synchronous messages at least with a nominal (i.e. average) transmission interval given by Table 26.

Table 26 — Maximum values of nominal transmission interval, t_{NOM}

| Mode | t_{NOM} (max) |
|------------|------------------|
| T, C | 15 min |
| S | 120 min |
| R, N, F, H | 24 h |

The synchronous messages shall be of the type SND-NR, ACC-DMD or ACC-NR (C-fields 44 h, 48 h or 47 h). They shall contain a short or long header or a CI-field in the range $8C_h$ to $8F_h$ (see Table 28), because the access number is required. ACC-NR messages may be used just to maintain synchronisation. SND-NR, ACC-DMD and ACC-NR messages may be mixed.

The synchronous messages shall be transmitted at individual transmission intervals (measured from start of message to start of the next message) given by:

$$t_{ACC} = (1 + (|n_{ACC} - 128| - 64) / 2048) \times t_{NOM}$$

$$t_{NOM} = n \times 2 \text{ s}$$

where

t_{ACC} is the individual transmission interval from the message with the access number n_{ACC} to the next message;

n_{ACC} is the value of the access number (from 0 to 255);

t_{NOM} is the fixed nominal transmission interval within the range specified in Table 26;

n is a fixed positive integer.

The access number n_{ACC} is given by;

— EN 13757-3:2013, 5.9, when the CI-field of the frame deviates from $8C_h$ to $8F_h$,

— Clause 12.2.3, when the CI-field of the frame is $8C_h$ to $8F_h$.

The access number n_{ACC} shall be incremented modulus 256 after, and only after every synchronous transmission.

The tolerance of the fixed nominal transmission interval, t_{NOM} , shall be:

— +110/–30 ppm for meters operating in the temperature range –15 °C to +65 °C;

— +230/–30 ppm for all other meters.

A non-accumulative jitter on the nominal transmission interval due to discrete time quantisation is allowed. It shall for:

- $t_{NOM} < 300$ s be less than ± 1 ms,
- $t_{NOM} \geq 300$ s be less than ± 3 ms.

For messages with a CI-field that deviates from $8C_h$ to $8F_h$, all synchronous messages shall be marked as such by setting the sync-bit in the Configuration field of the Transport Layer. For the Configuration field refer to EN 13757-3:2013, 5.12.

For messages with a CI-field of $8C_h$ to $8F_h$, all synchronous messages shall be marked as such by setting the Synchronised Subfield in the Communication Control Field. For the Communication Control Field refer to 12.2.2.

Additional non-synchronous messages may be transmitted, according to the timing rules of this standard, e.g. in bidirectional communication. The non-synchronous messages shall be marked as such by a cleared sync-bit respectively Synchronised Subfield.

Meters using the S1- and S2-Mode shall always transmit synchronous messages using the long preamble to support a battery efficient communication partner.

The meter manufacturers are strongly recommended to initialise the access numbers and internal transmission timers of different meters with widely distributed random values to avoid systematic collisions.

The meter may omit single synchronous transmissions if a task of higher priority (e.g. a metrological algorithm that cannot be postponed) needs to be performed at the scheduled transmission point in time. The rate of omitted synchronous messages shall not exceed 6,25 % per sliding 24 h time period. The access number, n_{ACC} , shall be incremented as if all synchronous transmissions had been executed.

Annex D shows an example for the prediction of a synchronous transmission time.

11.6.3 Access timing

11.6.3.1 General

This subclause describes the timing which the Other Device communication has to consider for a successful access to a Meter.

11.6.3.2 Mode R, S, T, C, N and F: Access to meter

For the R-, S-, T-, C-, N-, and F- Modes the Other Device can access the R2, S2, T2, C2, F2 or N2 Meter only if the meter is ready to receive.

The R-, S-, T-, C-, N- and F- Meter signals, for every transmission, its own accessibility in either the Configuration Word of the Transport Layer, see Configuration Word in EN 13757-3, or in the Communication Control Field of the extended Link Layer, see 12.2.2. The Other Device shall, before it transmits a message to the Meter; check the accessibility of the meter in the previously received frame from the Meter; see Table 27.

Table 27 — Accessibility of an R-, S-, T-, C-, N-, F- meter

| Bit B ^a | Bit A ^b | Accessibility of the meter |
|-----------------------------------------------------------------------------------------------------------------------------------------------------------------------------------------------------------------------------------------------------------------------------------------------------------|--------------------|--------------------------------------------------------------------------------------------------------------------------------------------------------------------------------------------------------------------------|
| 0 | 0 | No access - Meter provides no access windows (unidirectional meter) |
| 0 | 1 | Temporary no access - Meter supports bidirectional access in general, but there is no access window after this transmission (e.g. temporary no access in order to keep duty cycle limits or to limit energy consumption) |
| 1 | 0 | Limited access - Meter provides a short access windows only immediately after this transmission (e.g. battery operated meter) |
| 1 | 1 | Unlimited access – Meter provides unlimited access at least until next transmission (e.g. mains powered devices) |
| ^a Bit B refers to either Bit 15 in the Configuration word, see EN 13757-3, or to Bit 7 in the Communication Control Field, see 12.2.2.2. ^b Bit A refers to either Bit 14 in the Configuration word, see EN 13757-3 or to Bit 2 in the Communication Control Field, see 12.2.2.7. | | |

Examples of this are;

No access - Unidirectional meters (modes S1, T1, C1 or N1) are never accessible.

Temporary no access - If a bidirectional meter is not ready to respond by the reason of energy limitation, duty cycle or other reasons then it shall declare “temporary no access”.

Limited access - Battery operated meters are often very restricted in their energy consumption. They will provide a short access window only immediately after the transmission. The Other Device (as master) may initiate a communication to the Meter (as a slave) during this timeslot. The beginnings and the end of the timeslot are given as response delay t_{RO} in Table 5, Table 8, Table 12, Table 15 and Table 19.

Unlimited access - Mains powered Meters have typically sufficient energy to keep the receiver ready to receive all the time. Therefore the Other Device may send a command or a request at any time. It is limited by duty cycle requirements only. Even battery powered devices may signal temporary unlimited access as long as the receiver is continuously ready to receive.

11.6.3.3 Frequent Access Cycle

The Other Device may send/request several messages to/from the Meter. If one message of the message sequence is corrupted, the communication will be interrupted. The Other Device has to wait until the next regular transmission of the Meter to continue the sequence. The data exchange will be more reliable if the bidirectional meter supports the optional Frequent Access Cycle.

If a Meter receives a command or request to its address, it switches to the Frequent Access Cycle. During the Frequent Access Cycle, the Meter shall repeat the last message periodically with a FAC-Transmission delay t_{TXD} until the next request/command is received. This offers the Other Device a fast access to the meter even in case of a lost message. The Frequent Access Cycle lasts until the FAC-Timeout t_{TO} after the last successful reception of a command or a request from the same communication partner (Other Device). The Other Device can stop the Frequent Access Cycle of the Meter earlier by sending a SND-NKE-message to the meter at the end of the communication. The timing of the Frequent Access Cycle is shown in Annex E.

NOTE The Transmission delay t_{TXD} considers the case of an additional radio network between the Other Device and the Meter itself. Such a network delays the Meter message as well as the next request of the Other Device. It is also noted that many readout sessions may be performed in parallel in a short time period. To avoid collisions of meter messages with those of other meters, an off-time between the transmissions needs to be considered.

11.7 Repeated or duplicate messages

The use of simple repeaters may cause the reception of duplicate messages. Messages from a repeater are tagged by the Hop Count-bit, and depending on the type of repetition as well by the Repeated Access-bit. These bits are located in the Extended Link Layer or the Transport Layer Configuration Word. Refer to EN 13757-5 for details. Meters, in particular those with permanent receivers and Other Devices, shall be able to identify and discard duplicate messages.

12 Connection to higher protocol layers

12.1 The Control Information Field (CI-field)

The CI-field specifies the structure of the next higher protocol layer. The first byte after the Data Link Layer is this CI-field. The rest of the message depends on the selected layer and the application protocol used.

For the transport of the Application Layer information by this wireless communication standard the Transport Layer with short or long header should be used. Both Transport Layers always contains an access number and the configuration word. As an alternative, the Extended Link Layer may be applied.

The value of the CI-field shall be used as specified in Table 28.

Table 28 — CI-field

| CI-value | Designation | Remarks |
|-----------------|-------------------------------------------------------------------------------------------------|------------------------------------------------------------------------------------|
| 51 _h | Data sent by the Readout device to the Meter without Transport Layer (to be defined) | For compatibility with EN 13757-3 Application Layer standard |
| 5A _h | M-Bus Data sent by the Readout device to the Meter with short Transport Layer | For support of EN 13757-3 combined Transport and Application Layer |
| 5B _h | M-Bus Data sent by the Readout device to the Meter with long Transport Layer | For support of EN 13757-3 combined Transport and Application Layer |
| 60 _h | COSEM Data sent by the Readout device to the Meter with long Transport Layer | For support of EN 13757-1 and EN 62056-53 combined Transport and Application Layer |
| 61 _h | COSEM Data sent by the Readout device to the Meter with short Transport Layer | For support of EN 13757-1 and EN 62056-53 combined Transport and Application Layer |
| 64 _h | Reserved for OBIS-based Data sent by the Readout device to the Meter with long Transport Layer | Reserved for combined Transport and Application Layer |
| 65 _h | Reserved for OBIS-based Data sent by the Readout device to the Meter with short Transport Layer | Reserved for combined Transport and Application Layer |
| 69 _h | EN 13757-3 Application Layer with Format frame and no Transport Layer | For compatibility with EN 13757-3 Application Layer standard |
| 6A _h | EN 13757-3 Application Layer with Format frame and with short Transport Layer | For compatibility with EN 13757-3 Application Layer standard |
| 6B _h | EN 13757-3 Application Layer with Format frame and with long Transport Layer | For compatibility with EN 13757-3 Application Layer standard |
| 6C _h | Clock synchronisation (absolute) | Time service |
| 6D _h | Clock synchronisation (relative) | Time service |
| 6E _h | Application error from Meter with short Transport Layer | For support of EN 13757-3 combined Transport and Application Layer |
| 6F _h | Application error from Meter with long Transport Layer | For support of EN 13757-3 combined Transport and Application Layer |
| 70 _h | Application error from Meter without Transport Layer | For support of EN 13757-3 Application Layer |

| CI-value | Designation | Remarks |
|-----------------|----------------------------------------------------------------------------|-------------------------------------------------------------------------------------------|
| 71 _h | Alarm from Meter without Transport Layer | For support of EN 13757-3 Application Layer |
| 72 _h | EN 13757-3 Application Layer with long Transport Layer | For compatibility with EN 13757-3 combined Transport and Application Layer |
| 73 _h | EN 13757-3 Application Layer with Compact frame and long Transport Layer | For compatibility with EN 13757-3 combined Transport and Application Layer |
| 74 _h | Alarm from Meter with short Transport Layer | |
| 75 _h | Alarm from Meter with long Transport Layer | |
| 78 _h | EN 13757-3 Application Layer without Transport Layer | For compatibility with EN 13757-3 combined Transport and Application Layer |
| 79 _h | EN 13757-3 Application Layer with Compact frame without Transport Layer | For compatibility with EN 13757-3 combined Transport and Application Layer |
| 7A _h | EN 13757-3 Application Layer with short Transport Layer | For compatibility with EN 13757-3 combined Transport and Application Layer |
| 7B _h | EN 13757-3 Application Layer with Compact frame with short Transport Layer | For compatibility with EN 13757-3 combined Transport and Application Layer |
| 7C _h | COSEM Application Layer with long Transport Layer | For support of DLMS/COSEM Application Layer with OBIS identifiers (EN 62056-53) |
| 7D _h | COSEM Application Layer with short Transport Layer | For support of DLMS/COSEM Application Layer with OBIS identifiers (EN 62056-53) |
| 7E _h | Reserved for OBIS-based Application Layer with long Transport Layer | For support of the combined Transport and Application Layer |
| 7F _h | Reserved for OBIS-based Application Layer with short Transport Layer | For support of the combined Transport and Application Layer |
| 80 _h | EN 13757-3 Transport Layer (long) from Readout device to the Meter | For support of EN 13757-3 Transport Layer without Application Layer (e.g. REQ-UD2) |
| 81 _h | Network Layer data | For compatibility with the EN 13757-5 Network Layer standard |
| 82 _h | For future use | For compatibility with CENELEC TC 205 standards |
| 83 _h | Network Management application | For compatibility with the EN 13757-5 Network Layer standard |
| 84 _h | Transport layer to Meter (M Bus-Compact frame expected) | For support of EN 13757-3 Transport Layer without Application Layer e.g. REQUD2 |
| 85 _h | Transport layer to Meter (M Bus-Format frame expected) | For support of EN 13757-3 Transport Layer without Application Layer e.g. REQUD2 |
| 89 _h | Reserved for Network management data (EN 13757-5) | For compatibility with the EN 13757-5 Network Layer standard |
| 8A _h | EN 13757-3 Transport Layer (short) from the Meter to the Readout device | For support of EN 13757-3 Transport Layer without Application Layer (e.g. ACK) |
| 8B _h | EN 13757-3 Transport Layer (long) from the Meter to the Readout device | For support of EN 13757-3 Transport Layer without Application Layer (e.g. ACK) |
| 8C _h | Extended Link Layer I (2 Byte) | Additional Link Layer may be applied for Radio messages with or without Application Layer |
| 8D _h | Extended Link Layer II (8 Byte) | Additional Link Layer may be applied for Radio messages with or without Application Layer |
| 8E _h | Extended Link Layer III (10 Byte) | Additional Link Layer may be applied for Radio |

| CI-value | Designation | Remarks |
|-------------------------------------------------------------------------------------------------------------------------------------------------------------------------------------------------------------------------------|-----------------------------------------|-------------------------------------------------------------------------------------------|
| | | messages with or without Application Layer |
| 8F _h | Extended Link Layer IV (16 Byte) | Additional Link Layer may be applied for Radio messages with or without Application Layer |
| A0 _h – B7 _h | Manufacturer specific Application Layer | |
| NOTE This is an extract of the table in EN 13757-3:2013 with the values applicable to wireless communication. The term readout device is from EN 13757-3:2013. It corresponds to “Other Device” in this part of the standard. | | |

12.2 CI –fields for the Extended Link Layer

12.2.1 General

The Extended Link Layer provides additional control fields especially for wireless communication. Additional layers as listed in Table 28 (exclude the CI-fields 8C_h to 8F_h) may follow after the Extended Link Layer.

In the case of an Extended Link Layer, the CI-field specifies the length and the structure of the extension. Each type of Extended Link Layer provides different services.

Multi byte fields shall be transmitted with low byte first. The length and structure of the Extended Link Layer is illustrated in Table 29:

Table 29 — CI-fields for the Extended Link Layer

| CI-value | Length Extended Link Layer | Structure Extended Link Layer | Service |
|-----------------|----------------------------|---------------------------------|-------------------------------------------------------------------------|
| 8C _h | 2 bytes | CC, ACC | Communication Control, Synchronisation |
| 8D _h | 8 bytes | CC, ACC, SN, PayloadCRC | Communication Control, Synchronisation, Encryption |
| 8E _h | 10 bytes | CC, ACC, M2, A2 | Communication Control, Synchronisation, Destination Address |
| 8F _h | 16 bytes | CC, ACC, M2, A2, SN, PayloadCRC | Communication Control, Synchronisation, Destination Address, Encryption |

Examples of the different structures of the extension block are shown in Annex G.

12.2.2 Communication Control Field (CC-field)

12.2.2.1 General

This field, as shown in Figure 9 is a combination of the Bi-directional subfield, the Response Delay subfield, the synchronised Subfield, the Hop Count subfield, the Priority subfield, the Accessibility subfield and the Repeated Access subfield. Bit 0 is reserved for future use.

| B-field | D-field | S-field | H-field | P-field | A-field | R-field | (RFU) |
|---------|---------|---------|---------|---------|---------|---------|-------|
| Bit 7 | Bit 6 | Bit 5 | Bit 4 | Bit 3 | Bit 2 | Bit 1 | Bit 0 |

Figure 9 — Communication Control Field

12.2.2.2 Bi-directional Subfield (B-field)

Bit 7 of the Communication Control Field is the Bi-directional subfield. B=0 indicates that this frame is a unidirectional frame. B=1 indicates that this frame is a bidirectional frame, i.e. that the Meter will be ready to receive a response after a response delay. This bit has to be used in context with the A-Field. The use of this bit is identical to the Bit B in Table 27.

12.2.2.3 Response Delay Subfield (D-field)

Bit 6 of the Communication Control Field is the Response Delay subfield. D=1 indicates that the responding unit shall respond after a fast response delay. D=0 indicates that the slow response delay shall be used. If the Meter receives a frame with D=0 it shall also specify D=0 in the next frame from the Meter to the Other Device. This enables the Other Device to control the speed of the communication and thereby the channel occupation. It is, in fixed networks without the requirement for a fast response time, recommended always to use D=0 in frames from the Other Device to the Meter. It is, in all other networks, recommended always to use D=1. For timing diagrams, see Annex E.

12.2.2.4 Synchronised Subfield (S-field)

Bit 5 of the Communication Control Field is the Synchronised subfield. S=1 indicates that this frame is synchronised as specified in 11.6.2.

12.2.2.5 Hop Count Subfield (H-field)

Bit 4 of the Communication Control Field is the Hop Count subfield. If H=0, the direct source of the frame is a Meter or an Other Device. If H=1, the frame has been relayed by a repeater. This field is reserved for use in repeated messages; see EN 13757-5. A Meter shall always transmit with H=0.

12.2.2.6 Priority Subfield (P-field)

Bit 3 of the Communication Control Field is the Priority subfield. If P=0, the frame contains data that is to be treated in a normal manner. P=1 indicates that the frame is prioritised, i.e. the data shall be transported as fast as possible, and if necessary, delaying other frames in the system. Only frames containing alarms and other non-frequent data shall utilise this bit.

12.2.2.7 Accessibility Subfield (A-field)

Bit 2 of the Communication Control Field is the Accessibility Subfield. A=0 indicates there is only limited access to the Meter. A=1 indicates, that access is unlimited, at least until next Meter transmission. This bit has to be used in context with the B-Field. The use of this bit is identical to the Bit A in Table 27.

12.2.2.8 Repeated Access Subfield (R-field)

Bit 1 of the Communication Control Field is the Repeated Access subfield. This field is reserved for use in repeated messages; see EN 13757-5. A Meter shall always set R=0 and may ignore this bit when received.

12.2.3 Access Number Field (ACC-field)

This field is the Access Number Field. The Access Number is used to identify and synchronise the transmissions from a Meter, see 11.6.2. For further specification, refer to EN 13757-3.

12.2.4 Manufacturer ID 2 (M2-field).

This field M2 shall contain a unique User/Manufacturer ID of the destination for this frame. The formatting of the M2 field shall be as for the M field specified in 11.5.5. The M2-field and the A2-field shall together generate a unique address.

12.2.5 Address 2 (A2-field)

This field A2 shall, together with the M2 field, contain a unique Address of the destination for this frame. The formatting of the A2 field shall be as for the A field specified in 11.5.6.

12.2.6 Session Number Field (SN-field)

12.2.6.1 General

This field (see Figure 10) is a combination of the Encryption subfield, the Time-subfield and the Session subfield. The session number specifies the actual bidirectional communication session with a Meter. The session number is specified by the Meter in the initial transmitted frames, i.e. “SND-NR” or “ACC-NR” frames. During a bidirectional communication session with the Meter, the session number is unchanged. The Session Number Field value shall at least be changed after every bidirectional communication session with the Meter. This ensures that every bidirectional communication session with a Meter uses a unique Session Number field value.

The use of a session number that is never reused during the lifetime of the meter gives the possibility to use optimised encryption modes like the AES-128 Counter Mode Encryption.

| ENC-field | Time-field | Session-field |
|-----------------|----------------|---------------|
| Bit 31 – Bit 29 | Bit 28 – Bit 4 | Bit 3 – Bit 0 |

Figure 10 — Session Number Field

12.2.6.2 ENC-subfield

Bit 31 to Bit 29 of this field is the Encryption Subfield. This specifies the encryption algorithm used, if any as given in Table 30.

Table 30 — Encryption

| XXX _b | Encryption selection |
|------------------|-----------------------------------|
| 000 | No encryption |
| 001 | AES-128 Counter Mode ^a |
| 010 to 111 | Reserved for future use |
| a | See 12.2.7 |

NOTE When Link Layer Encryption is used, the frame needs to be decrypted before it is passed to the upper layers.

12.2.6.3 Time-subfield

Bit 28 to Bit 4 of this field describes the time of the meter. The Time-field describes a relative minute counter of the meter. Maximum time representation is approximately 64 years.

12.2.6.4 Session-subfield

Bit 3 to Bit 0 of this field describes the session within the minute specified by the Time-field. Within the same minute a maximum of 16 bidirectional communication sessions are possible. The first bidirectional communication session in every minute uses session = 0.

12.2.6.5 Specification of a session

In every transmission initiated by the Meter, i.e. “SND-NR” or “ACC-NR”, the Meter specifies a new Session Number Field. The actual value of the Session Number Field identifies the time of the Meter counted in minutes and the actual session within this minute. If the Other Device responds to this frame, a bidirectional communication session with the actual session number is established. Within this bidirectional communication session, the Session Number Field is unchanged.

The Session Number Field in frames from Other Device to Meter shall always be identical to the initial Session Number Field of the session defined by the Meter.

If the payload in the frame is unchanged since the last transmission from the Meter the Session Number field value can be reused. The Session Number field value shall at least be renewed every 300 s.

12.2.7 AES-128 Counter Mode Encryption

12.2.7.1 General

If the Encryption Subfield is ENC = 001_p, a standard AES-128 encryption in counter mode (CTR) shall be used (see FIPS PUB 197, NIST SP800-38A and Annex F). The counter mode encryption does not require the length of the encrypted data to be a multiple of 16 bytes resulting in that no extra padding bytes need to be added to the end of the frame.

The encryption covers all fields from and including the Payload CRC-field of the Extended Link Layer to the rest of the frame (not including the CRC-fields of the link layer). The AES-128 counter mode Initial Counter Block consists of 16 bytes as specified below. The Initial Counter Block (see Figure 11) is made in a way that the value of the Initial Counter Block is unique for every encrypted block during the lifetime of the meter.

| M-field | A-field | CC-field | SN-field | FN | BC |
|----------------|----------------|-----------------|-----------------|-----------|-----------|
| 2 bytes | 6 bytes | 1 byte | 4 bytes | 2 bytes | 1 byte |

Figure 11 — AES-128 (CTR) Initial Counter Block

12.2.7.2 Manufacturer ID field (M-field)

The value is retrieved from the first block of the Data Link Layer. See 11.5.5.

12.2.7.3 Address field (A-field)

The value is retrieved from the first block of the Data Link Layer. See 11.5.6.

NOTE The M-field and A-field contains the address of the sender and differs between up and downlink messages.

12.2.7.4 Communication Control Field (CC-field)

The value is retrieved from the Extended Link Layer. See 12.2.2. The bits of the Communication Control Field handled by the repeater (R-field and H-field) are always set to zero in the Initial Counter Block.

12.2.7.5 Session Number Field (SN-field)

The value is retrieved from the Extended Link Layer. See 12.2.6.

12.2.7.6 Frame Number (FN)

This field represents the Frame Number within the actual session. A new session number resets the Frame Number. The Frame Number shall count up for every frame in the current session. The first frame from the Meter to the Other Device initiated by the meter is always sent with FN = 0. In case of retransmission of a

frame during the Frequent Access Cycle, see 11.6.3.3. The Frame Number is unchanged. For examples on the use of frame counter, see Annex E.

12.2.7.7 Block Counter (BC)

The Block Counter represents the encryption block number within the frame. The Block Counter shall be BC = 0 for the first encrypted block in each frame, and increments for each encrypted block in the frame.

12.2.8 Payload Checksum Field (PayloadCRC-field)

The last two bytes of the extension block contain a CRC checksum of the remainder of the frame (excluding the CRC-fields of the link layer).

The CRC polynomial to use shall be $x^{16} + x^{13} + x^{12} + x^{11} + x^{10} + x^8 + x^6 + x^5 + x^2 + 1$.

The initial value shall be 0.

The final CRC shall be complemented.

12.3 CI-fields for the Transport Layer

12.3.1 General

A plain Transport Layer should be used for messages without application data. Otherwise, a combined Transport and Application Layer may be used. Multi byte fields shall be transmitted with low byte first.

12.3.2 Short Transport Layer

The Short Transport Layer (CI=8A_h) shall be applied for communication from Meter to Other Device (e.g. for a message ACK). The format shall be as shown in Figure 12.

| CI | ACC | STS | Conf. Word |
|--------|--------|--------|------------|
| 1 byte | 1 byte | 1 byte | 2 bytes |

Figure 12 — Short Transport Layer

12.3.3 Long Transport Layer

The Long Transport Layer (which includes the Application Layer Address, ALA) shall be applied for communication from the Meter to the Other Device (CI=8B_h; e.g. for a message type ACK) or from the Other Device to the Meter (CI=80_h; e.g. for a message type REQ-UD2). The format shall be as shown in Figure 13.

| CI | Ident no. | Manuf. | Ver. | Device Type | ACC | STS | Conf. Word |
|--------|-----------|---------|--------|-------------|--------|--------|------------|
| 1 byte | 4 bytes | 2 bytes | 1 byte | 1 byte | 1 byte | 1 byte | 2 bytes |

Figure 13 — Long Transport Layer

Annex A (informative)

Frequency allocation and band usage for the 868 MHz band

The allocation of frequencies for different services is shown in Figure A.1 below:

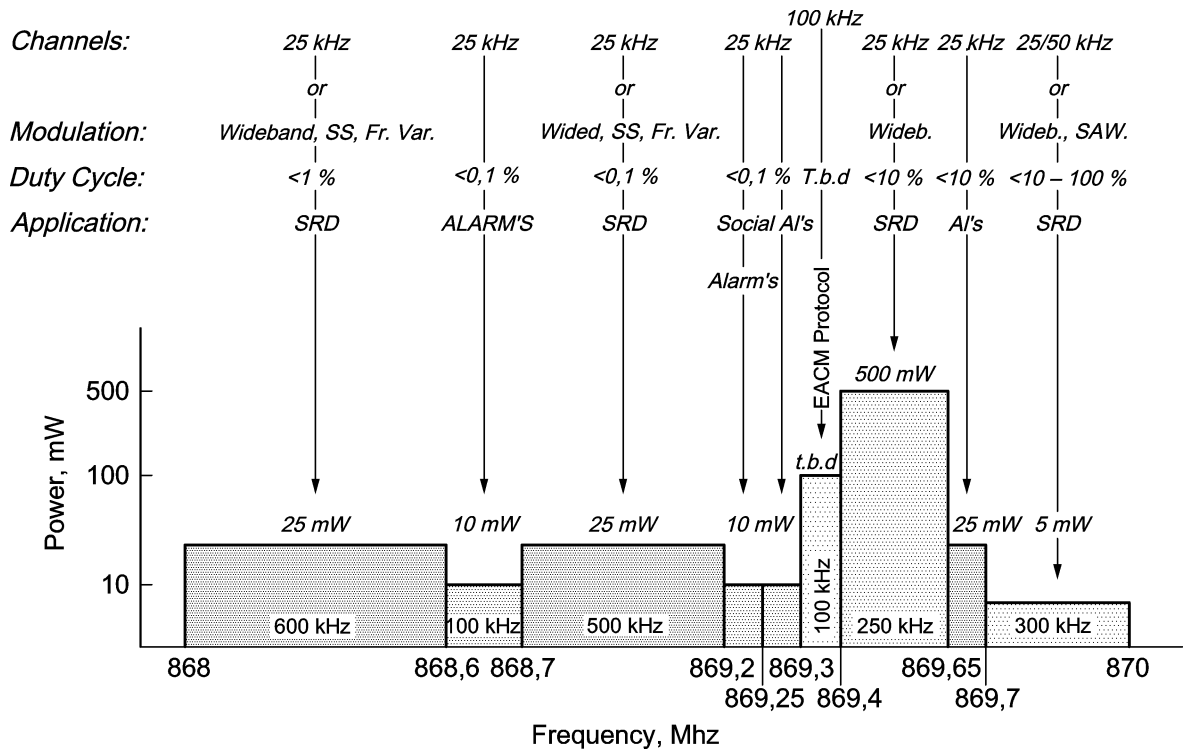

Figure A.1 — Frequency and power allocation in the 868 MHz band

Annex B
(informative)

Flag, assignment of the “unique User/Manufacturer ID”, three letter codes

The unique User/Manufacturer code is presently administered by:

The Flag Association Ltd

c/o BEAMA Energy Ltd

Westminster Tower

3 Albert Embankment

London SE1 7SL

United Kingdom.

<http://dlms.com/organization/flagmanufacturesids/index.html>

NOTE The postal address is subject to change, and can be obtained through the internet address.

Annex C (informative)

Frame examples

C.1 Example of a frame from a meter in mode S

C.1.1 Conditions

The link layer frame length L (except the L-field and the CRC's) is $9 + 6 = 15$ bytes (see below). The C-field has the value 044_h ("SEND/NO REPLY, Meter initiative").

A meter from a (dummy) manufacturer "CEN" with a unique (hexadecimal) manufacturer number $12345678_h; 01_h; 07_h$ (Identification-number; Version; Device type) transmits a (decimal) volume of 876 543 l.

For the example, this is coded according to EN 13757-3 as: $DIF=0B_h$ (=6 digit BCD instantaneous value) and $VIF=13_h$ (= volume in litres).

The "CEN" is coded according to EN 13757-3 as "C" = $(43_h-40_h) = 3$, "E"=5, "N"=14. Thus "CEN"= $32 \times 32 \times 3 + 32 \times 5 + 14 = 3246_d = 0CAE_h$. Most significant bit is null since it is a "hard" (i.e. manufacturer unique) address.

C.1.2 Block content

The frame consists of two blocks:

- a) The first block, as defined in Figure 2, consists of 10 byte (by definition of this document) and 2 CRC bytes:
 - 1) $0F_h$ L-field according to EN 60870-5-1;
 - 2) 44_h C-field according to EN 60870-5-2;
 - 3) $0CAE_h$ Manufacturer code;
 - 4) $12345678_h; 01_h; 07_h$ Manufacturer number (Identification-number; Version; Device type).
- b) The second block consists of the CI-field plus, 5 user bytes and 2 CRC bytes:
 - 1) 78_h CI-field, without header, start immediately with VIF/DIF;
 - 2) $0B_h$ DIF = 3 byte BCD instantaneous value;
 - 3) 13_h VIF = Volume in litres;
 - 4) 876543_h = Number of litres (in BCD).

C.2 Example of a frame from a meter in mode T1

C.2.1 Condition

The link layer frame length L (except the L-field and the CRC's) is $9 + 6 = 15$ bytes (see below). The C-field has the value 044_{h} ("SEND/NO REPLY, Meter initiative").

A meter from a (dummy) manufacturer "CEN" with a unique (hexadecimal) manufacturer number 12345678_{h} ; 01_{h} ; 07_{h} Manufacturer number (Identification-number; Version; Device type) transmits a (decimal) volume of 876 543 l.

For the example, this is coded according to EN 13757-3 as: $\text{DIF}=0\text{B}_{\text{h}}$ (=6 digit BCD instantaneous value) and $\text{VIF}=13_{\text{h}}$ (=volume in litres).

The "CEN" is coded according to EN 13757-3 as "C"= $(43_{\text{h}}-40_{\text{h}})=3$, "E"=5, "N"=14. Thus "CEN"= $32 \times 32 \times 3 + 32 \times 5 + 14 = 3246_{\text{d}} = 0\text{CAE}_{\text{h}}$. Most significant bit is null since it is a "hard" (i.e. manufacturer unique) address.

C.2.2 Block Content

The frame consists of two blocks:

- a) The first block, as defined in Figure 2, consists of 10 bytes (by definition of this document) and 2 CRC bytes:
 - 1) 0F_{h} L-field according to EN 60870-5-1;
 - 2) 44_{h} C-field according to EN 60870-5-2;
 - 3) 0CAE_{h} Manufacturer code;
 - 4) 12345678_{h} ; 01_{h} ; 07_{h} Manufacturer number (Identification-number; Version; Device type).
- b) The second block consists of the CI-field, 5 user bytes and 2 CRC bytes:
 - 1) 78_{h} CI-field, without header, start immediately with VIF/DIF;
 - 2) 0B_{h} DIF = 3 byte BCD instantaneous value;
 - 3) 13_{h} VIF = Volume in litres;
 - 4) 876543_{h} = Number of litres (in BCD).

Since multi byte data (according to EN 13757-3) shall be transmitted with LSB first, the hex byte sequences without CRC's are:

- $0\text{F } 44 \text{ AE } 0\text{C } 78 \text{ 56 } 34 \text{ 12 } 01 \text{ 07}$ 1. block;
- $78 \text{ 0B } 13 \text{ 43 } 65 \text{ 87}$ 2. block.

The CRC according to FT3 of EN 60870-5-1 uses:

$$x^{16} + x^{13} + x^{12} + x^{11} + x^{10} + x^8 + x^6 + x^5 + x^2 + 1$$

as a generator polynomial. It starts with zero and treats the data 'most' significant bit first. The CRC result is complemented. The most significant byte of the 16-bit CRC is transmitted first.

The full hex byte string is then:

0F 44 AE 0C 78 56 34 12 01 07 44 47 78 0B 13 43 65 87 1E 6D.

C.2.3 Bit string

Coding each nibble via a 6 chip code according to the coding table results in:

010110 101001 011100 011100 100110 110010 010110 110100
010011 101100 011001 011010 001011 011100 001101 001110
010110 001101 010110 010011 011100 011100 011100 010011
010011 101100 010110 100011 001101 001011 011100 001011
011010 011001 101100 010011 001101 110010 011010 110001

Together with the header, the bit synchronisation pattern and the trailer this leads to the following total continuous chip string:

01010101010101010101010101010101010101010101010101010000111101
010110101001011100011100100110110010010110110100
010011101100011001011010001011011100001101001110
010110001101010110010011011100011100011100010011
010011101100010110100011001101001011011100001011
01101001100110110001001100110111001001101011000101

which contains a total of 290 chips. For mode T1 with a nominal chip rate of 100 kcps, the transmit duration will be 2,9 ms.

C.3 Example of a frame from a meter in mode C1

C.3.1 Conditions

In this example, the frame is in format B and it uses the Extended Link Layer with CI-field $8C_h$.

The link layer frame length L (except the L-field) is 20 bytes (see below).

The C-field has the value 44_h ("SEND/NO REPLY, Meter initiative").

A meter from a (dummy) manufacturer "CEN" with a unique (hexadecimal) manufacturer number 12345678_h ; 01_h ; 07_h Manufacturer number (Identification-number; Version; Device type) transmits a (decimal) volume of 876 543 l.

For the example, this is coded according to EN 13757-3 as: DIF= $0B_h$ (=6 digit BCD instantaneous value) and VIF= 13_h (=volume in litres).

The “CEN” is coded according to EN 13757-3 as “C”=(43_h-40_h)=3, “E”=5, “N”=14. Thus “CEN”= 32 × 32 × 3+32 × 5+14= 3246_d = 0CAE_h. Most significant bit is null since it is a “hard” (i.e. manufacturer unique) address.

The “Communication Control Field” of the Link Layer Extension is CC=20_h specifying that this is a synchronised frame. The counting “ACC Number Field” is in this example ACC=27_h.

C.3.2 Block content

Since the total length of the frame including the L-field and the CRC-field is less than 128, the frame consists of only one block as shown in Figure C.1.

| L-field | C-field | M-field | A-field | CI-field | CC-field | ACC-field | ... |
|-----------------|-----------------|-------------------|---------------------------------------------------------|-----------------|-----------------|-----------------|-----|
| 14 _h | 44 _h | 0CAE _h | 12345678 _h ;01 _h ;07 _h | 8C _h | 20 _h | 27 _h | ... |

| CI-field | DIF-field | VIF-field | Data-field | CRC-field |
|-----------------|-----------------|-----------------|---------------------|-------------------|
| 78 _h | 0B _h | 13 _h | 876543 _h | 7AC5 _h |

Figure C.1 — Mode C format B block content

Since multi byte data shall be transmitted with LSB first, the hex byte sequences without CRC are:

14 44 AE 0C 78 56 34 12 01 07 8C 20 27 78 0B 13 43 65 87

The CRC according to this standard uses:

$$x^{16} + x^{13} + x^{12} + x^{11} + x^{10} + x^8 + x^6 + x^5 + x^2 + 1$$

as a generator polynomial. It starts with zero and treats the data ‘most’ significant bit first. The CRC result is complemented. The most significant byte of the 16-bit CRC is transmitted first.

The full hex byte string is then:

14 44 AE 0C 78 56 34 12 01 07 8C 20 27 78 0B 13 43 65 87 7A C5.

C.3.3 Bit string

Coding each byte via NRZ with the most significant bit first results in:

0001 0100 0100 0100 1010 1110 0000 1100
 0111 1000 0101 0110 0011 0100 0001 0010
 0000 0001 0000 0111 1000 1100 0010 0000
 0010 0111 0111 1000 0000 1011 0001 0011
 0100 0011 0110 0101 1000 0111 0111 1010
 1100 0101

Together with the preamble and synchronisation this leads to the following total continuous chip string:

```
01010101010101010101010101010101010101010100001111010101010000111101  
0001010001000100101011100000110001111000010101100011010000010010  
000000010000011110001100001000000010011101111000000101100010011  
0100001101100101100001110111101011000101
```

which contains a total of 232 chips.

For mode C1 with a nominal chip rate of 100 kcps, the transmit duration will be 2,32 ms.

Annex D (informative)

Example of predictive reception of synchronous messages

To synchronise with the synchronous transmissions of a Meter, it is required to receive at least two synchronous messages. To do so with a reasonable failure rate, a continuous reception period of six nominal transmission intervals is recommended. Since the maximum of the nominal transmission interval is restricted e.g. in Mode T to 15 min, 90 min of continuous reception are adequate.

EXAMPLE Two synchronous messages with the access number values 110 and 112 have been received at a time difference of 1661,563 s. This is illustrated on Figure D.1 below. From the access number values can be seen that one message has been missed. Thus, the individual transmission interval between the two messages is:

$$\begin{aligned} t_{110} + t_{111} &= 1661,563 \text{ s} \\ &= (1 + (|110-128|-64)/2048) \times t_{NOM} + (1 + (|111-128|-64)/2048) \times t_{NOM} \\ &= (1 + (-46/2048) + 1 + (-47/2048)) \times t_{NOM} \end{aligned}$$

Now the nominal transmission interval, t_{NOM} , can be determined:

$$t_{NOM} = 1661,563 \text{ s} \times 2048 / (2048 - 46 + 2048 - 47) = 850,083 \text{ s}$$

The integer factor is $n = 425$.

With the nominal transmission interval, the expected individual transmission interval to the next synchronous transmission t_{112} can be determined:

$$t_{112} = (1 + (|112-128|-64)/2048) \times 850,083 \text{ s} = 830,159 \text{ s}$$

The nominal transmission interval for that meter can be recalculated after every reception of a new synchronous message of that meter to compensate temperature drift.

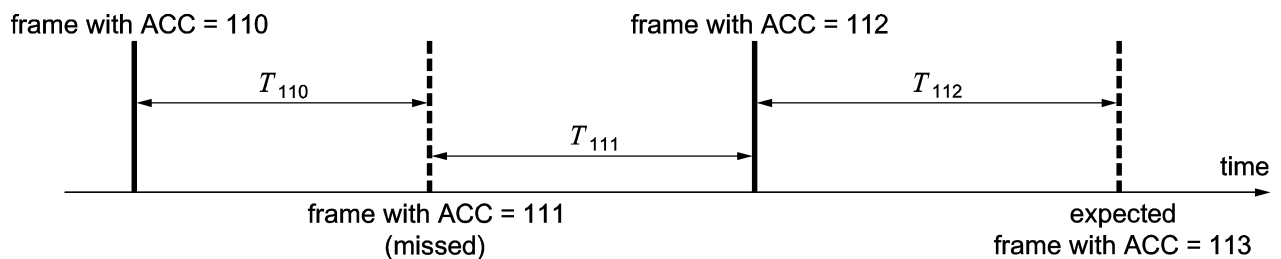

Figure D.1 — Prediction of the synchronous transmission time

Annex E (informative)

Timing diagrams

The next pages show examples of timing diagrams for installation or data transfer. Figure E.1 is an explanation of how to read the timing diagram. Figures E.2 to E.7 presents the generic timing applicable to all modes in this part of the standard.

The Figures E.8 to E.11 present the special timing of the C-Mode with emphasis on the handling of the special data elements Frame Number (FN) and Hop Count (H).

Special abbreviations used in this annex are; LLA = Link Layer Address, ALA = Application Layer Address, MTR = Meter, COM = Data Collector/ Concentrator, OMC = Other Meter Collector, RFA = Radio Frequency Adapter.

The different access timing of alternative reception windows has to be considered.

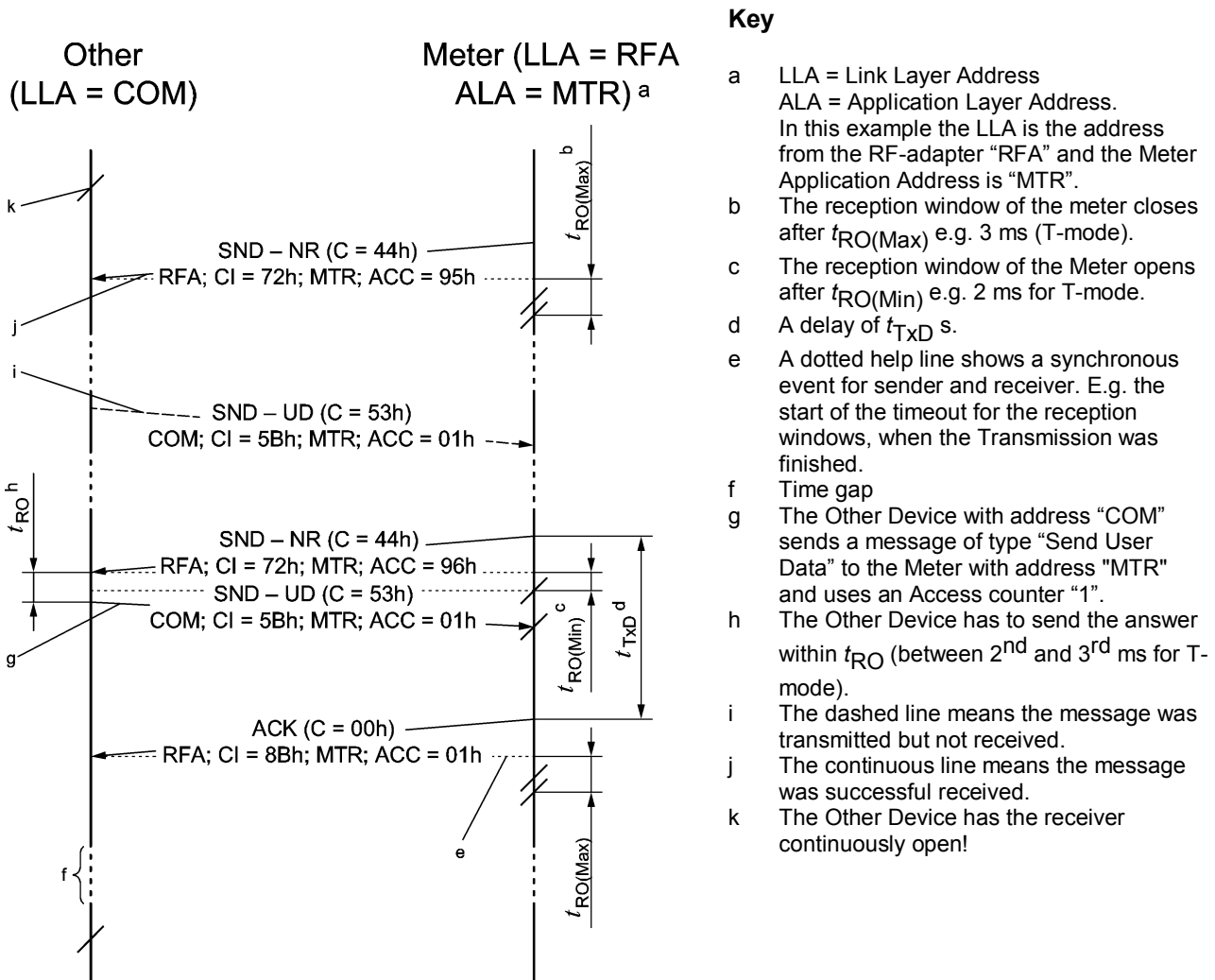
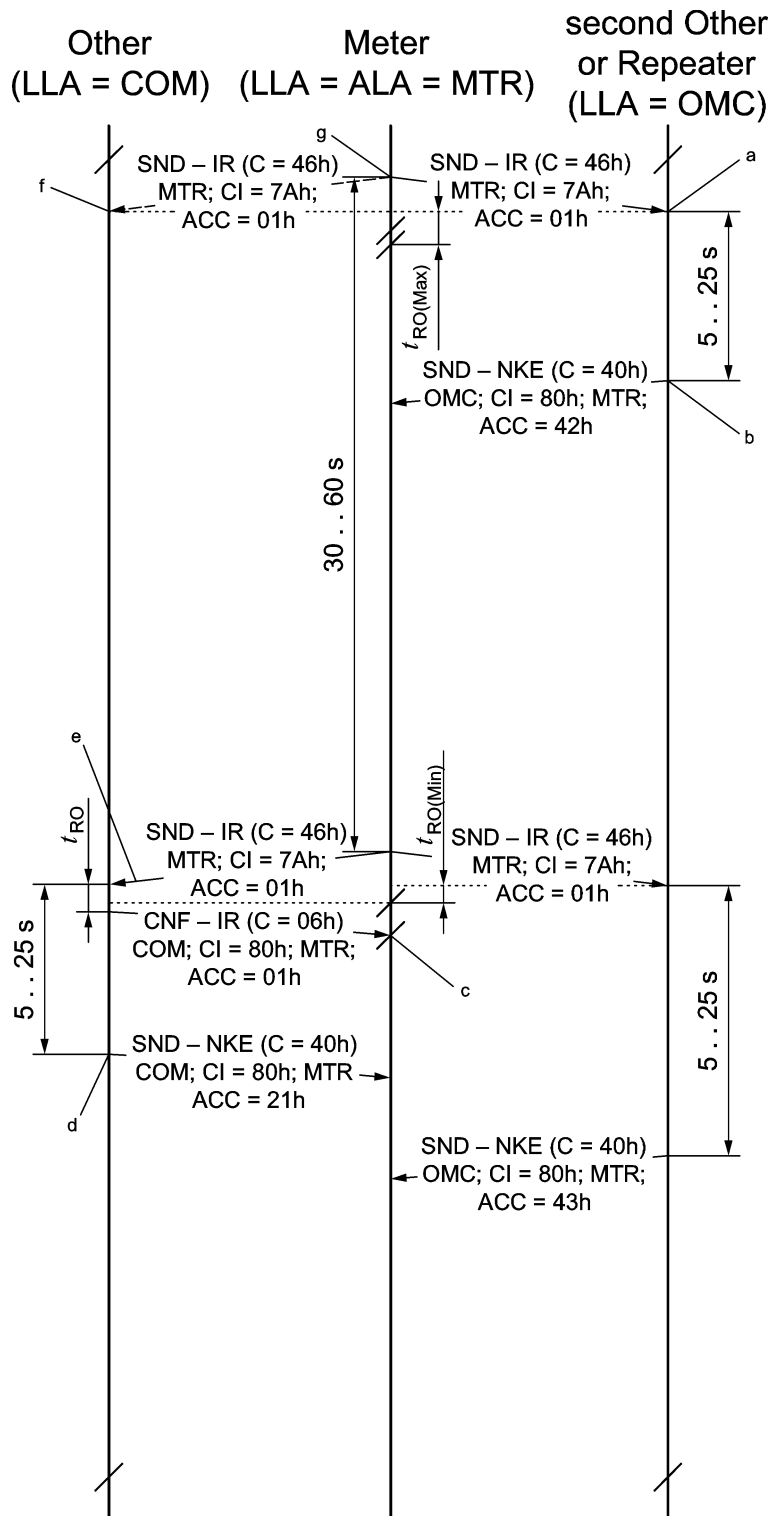

Figure E.1 — Legend



Key

- a The second Other Device does not accept this Meter.
- b However it sends a Link-reset after every reception of an installation request from the new installed meter after a random delay! This message signals an available radio link to an optional Service tool.
- c If the Meter receives the dedicated confirmation to its installation request it stops the transmission of installation request messages.
- d For a uniform behaviour the assigned Other Device sends a Link-reset after a random delay too.
- e The Other Device accepts this Meter. Hence it responds with an installation confirmation. An optional service tool may use this message to signal, that the Meter is logged in the COM.
- f The Other Device fails to receive the Meter.
- g During the installation mode the Meter generates periodical message of the type "Installation request" until the reception of the installation confirmation (CNF-IR) or the timeout.

Figure E.2 — Installation timing

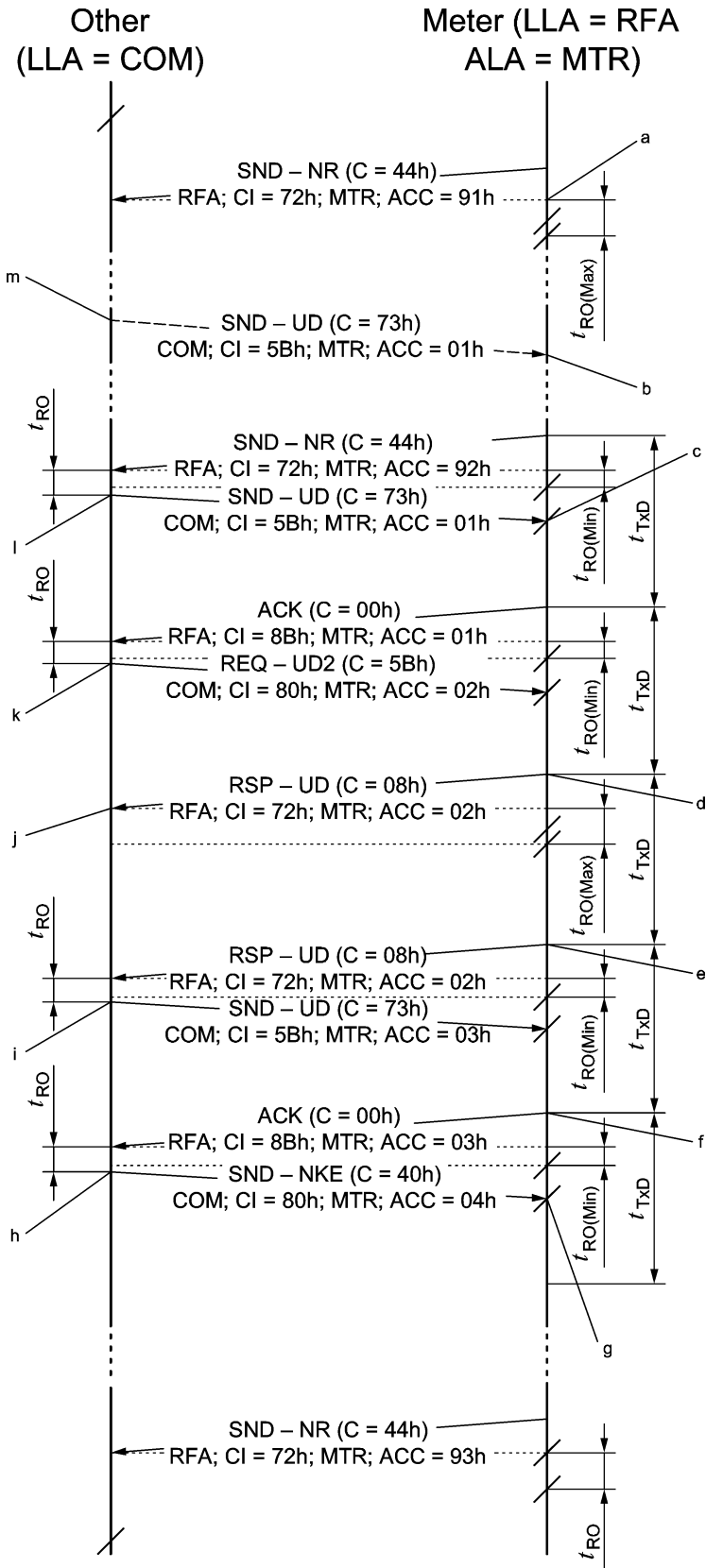

Key

- a A short reception windows follows after every transmission (if in Configuration word Bit B = 1 and Bit A = 0).
- b Since the receiver is not always open, the message is not received.
- c The message was received now. An acknowledge is responded with a predefined delay.
- d The Meter generates a response after the predefined delay.
- e The Meter does not receive the response and repeats the last message again after the predefined delay.
- f The Meter now receives a new command and generates an acknowledge after the predefined delay.
- g The Meter receives a SND-NKE (means "End of Transmission"). It stops the frequent access cycle.
- h The Other Device receives the acknowledge and finishes the session.
- i When the Meter allows access the Other Device sends the second command.
- j The Other Device processes the response. That is why it fails to send the second command in time. The Other Device has to wait for next access window.
- k The Other Device sends a request to read back the results of last transmitted command.
- l When the Meter provides access, the Other Device sends the command to the Meter.
- m The Other Device has a new command. It tries to contact the Meter immediately.

Figure E.3 — Connection applying long transport layer

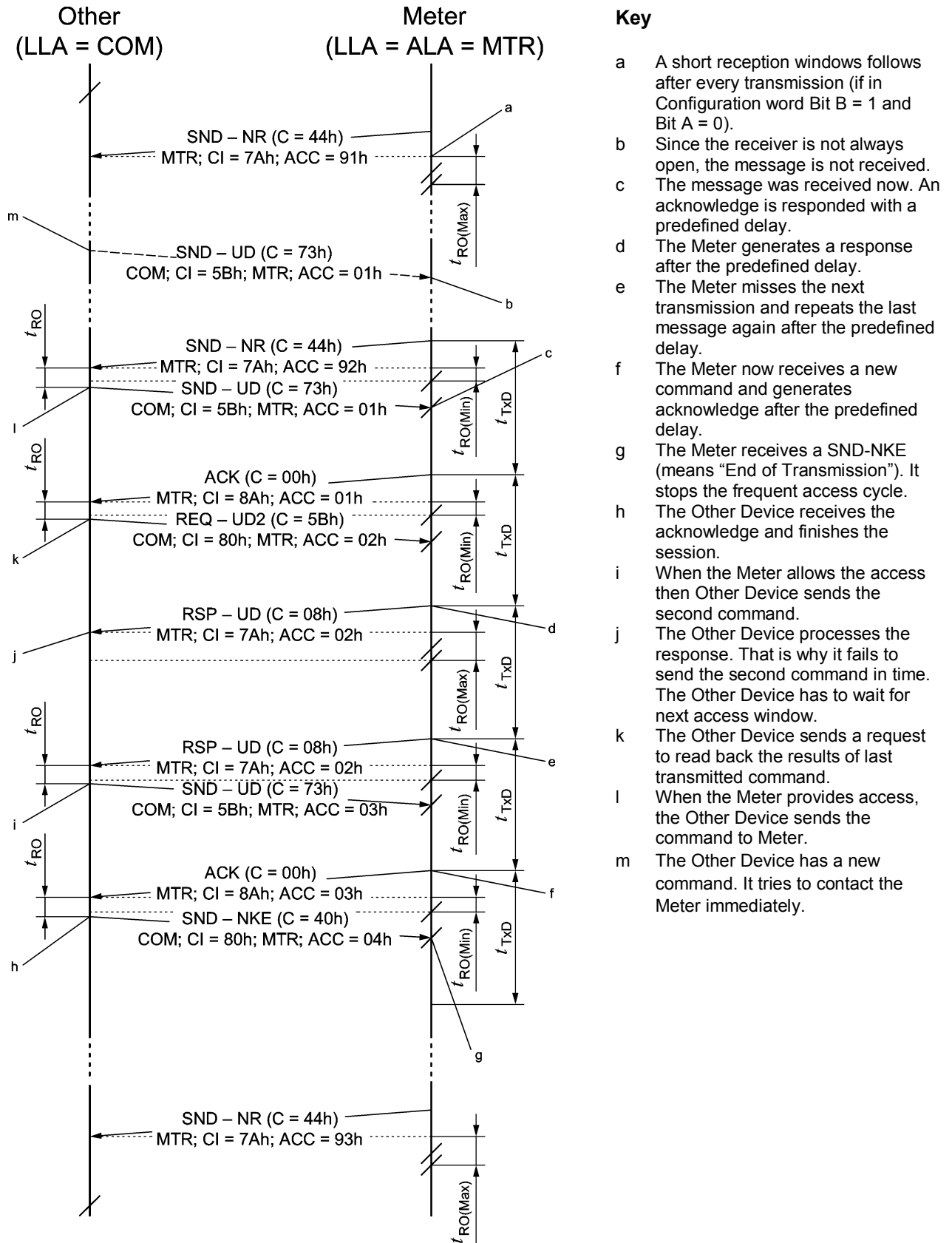
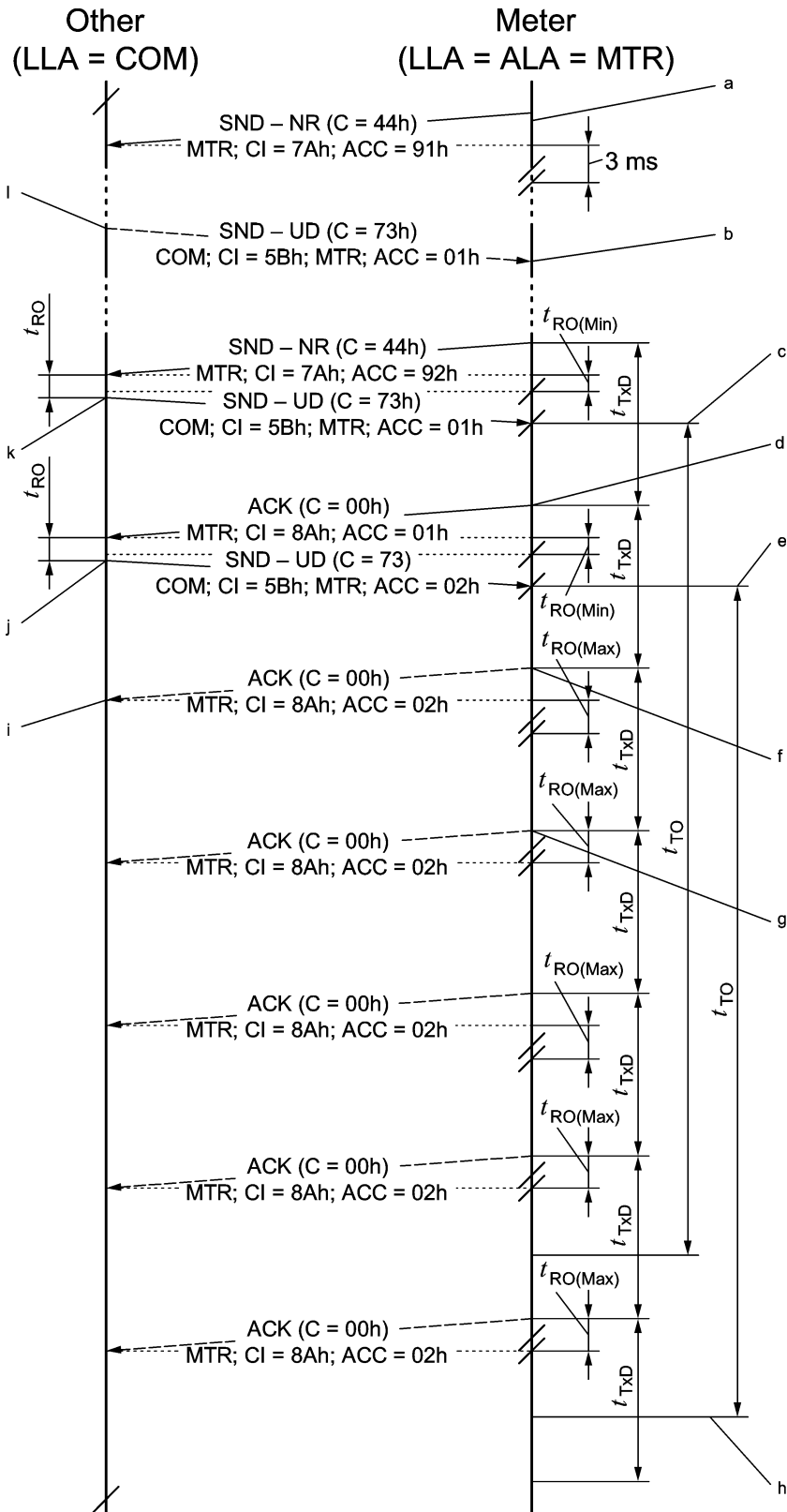

Figure E.4 — Connection applying short transport layer



Key

- a A short reception windows follows after every transmission (if in Configuration word Bit B = 1 and Bit A = 0).
- b Since the receiver is not always open, the message is not received.
- c The Meter receives the first message from the Other Device successfully. A Connection-timeout is started.
- d After the predefined delay the Meter sends the acknowledge with no. 1 as answer to the command with no. 1.
- e The Meter receives a second message from the Other Device successfully. The Connection-timeout is restarted again.
- f After the predefined delay the meter sends acknowledge with no. 2 for the first time.
- g If no further message from the Other Device is received, then the Meter repeats the last transmission periodically until connection timeout happens (end of frequent access cycle).
- h The Meter stops the message repetition by timeout!
- i The Other Device stops the communication for some reason.
- j The Other Device sends the next command to the Meter.
- k When the meter provides access the Other Device sends the command to Meter.
- l The Other Device has a new command. It tries to contact the Meter immediately.

Figure E.5 — Time out, Frequent Access Cycle

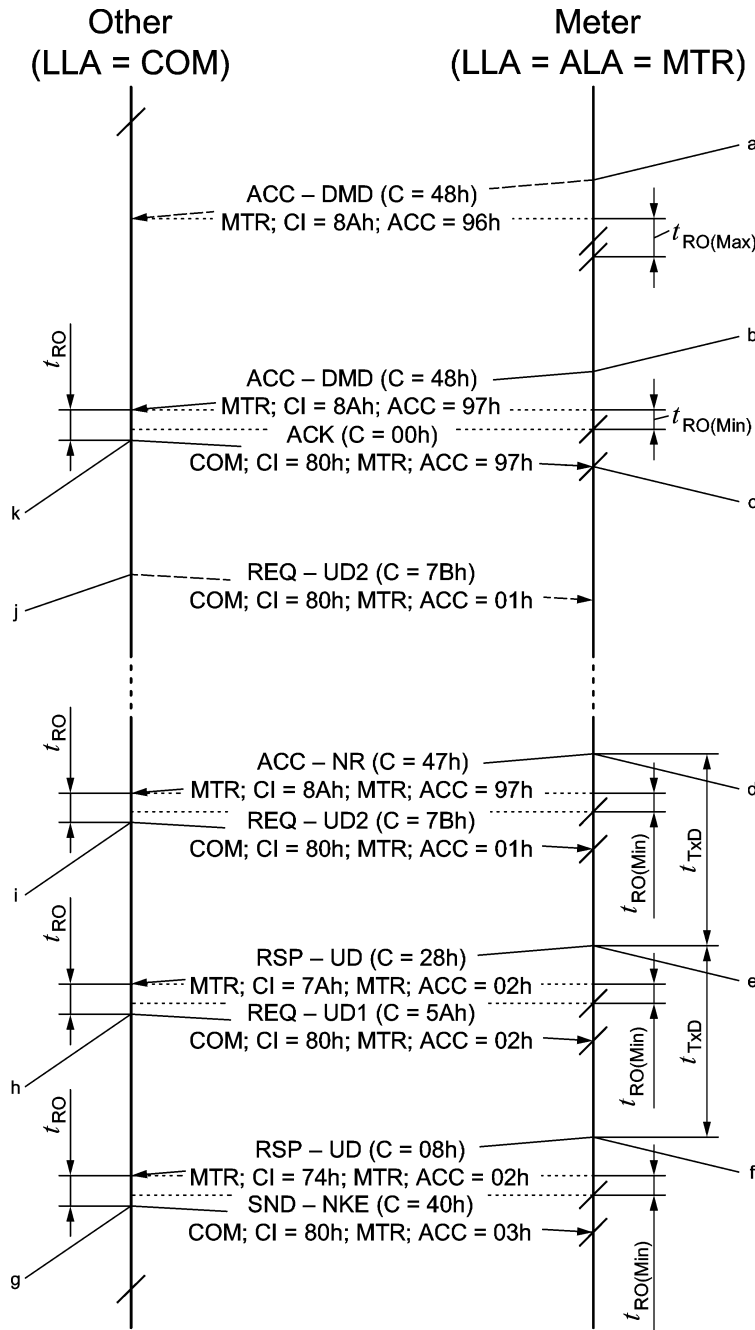

Key

- a The Meter has an alert and intend to inform the operator. It generates an access demand.
- b The Meter repeats the access demand until the Other Device acknowledges it.
- c The Meter stops the transmission of the access demand.
- d The Meter may accelerate the access by sending an aperiodic transmission.
- e The Meter provides status and normal consumption data. In this example an additionally set ACD-bit in the C-field informs the Other Device about available Alarm data (Class 1).
- f The Meter responds with an Alarm message. A clear ACD-bit signals there are no more Alarm data available.
- g The Other Device finishes the communication.
- h Triggered by the ACD-bit the Other Device will request the alarm data (Class 1) with the next unsolicited transmission of the Meter.
- i By the next unsolicited transmission of the Meter the Other Device requests the status data (Class 2). It may also ask for alarm data immediately!
- j The Other Device may try to read status of the Meter immediately.
- k The Other Device acknowledges that access demand was received and that it will be handled soon.

Figure E.6 — Access demand

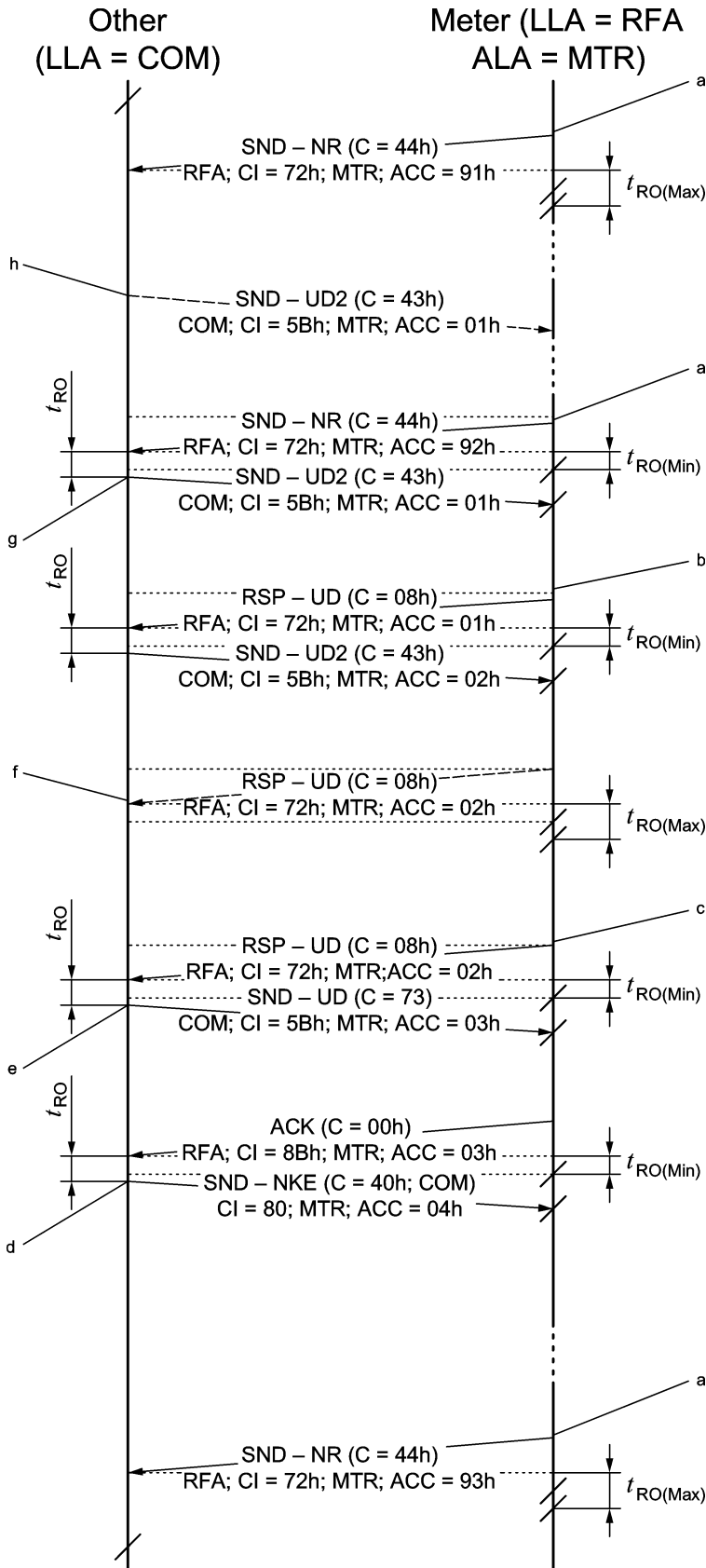

Key

- a Periodic transmission by the Meter.
- b The Meter answer directly with expected response instead of an ACK.
- c The Meter repeats the last message within the FAC.
- d If the Other Device finish all transaction it closes the Link using a SND-NKE.
- e After the reception of the outstanding response the Other Device continues with next command (here applying a SND-UD, which has to be responded with an simple ACK only).
- f The second response was not received, for any reasons.
- g The Other Device send a command and expected immediately a response. For that reason it applies a SND-UD2.
- h The Other Device may try to contact the Meter if it has no information about the accessibility of the Meter.

Figure E.7 — RF-connection using SND-UD2

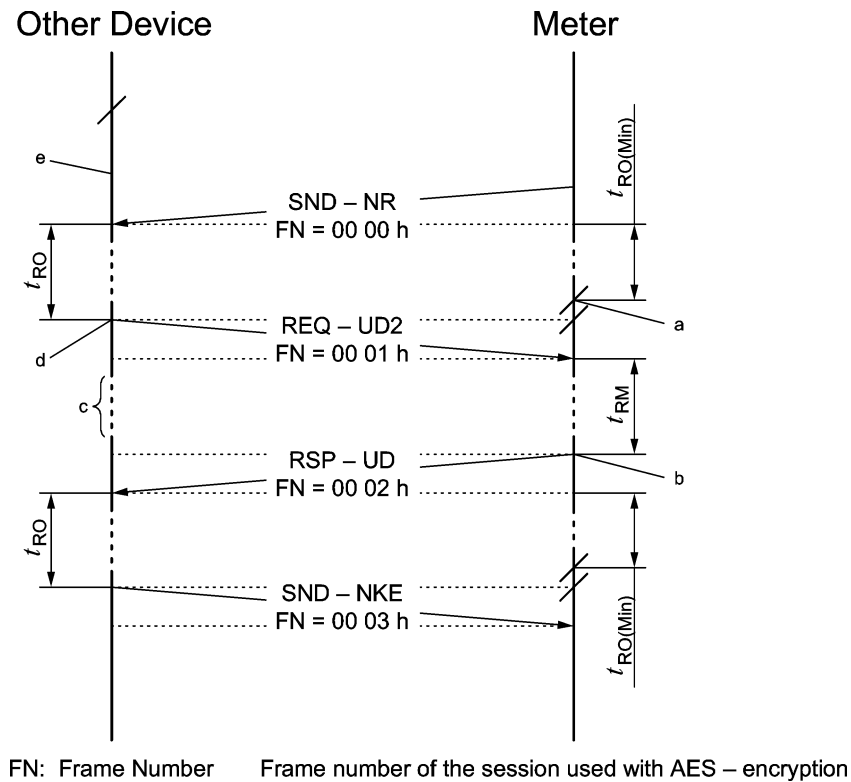

Key

- a “Meter” switches receiver on and listens after a delay ($t_{RO(Min)}$)
- b “Meter” responds after a delay (t_{RM})
- c Time gap
- d “Other Device” responds after a delay (t_{RO})
- e “Other Device” has the receiver continuously open

Figure E.8 — Mode C, normal transfer

This figure emphasises how the frame number will vary when encryption using AES is performed at the Data Link Layer.

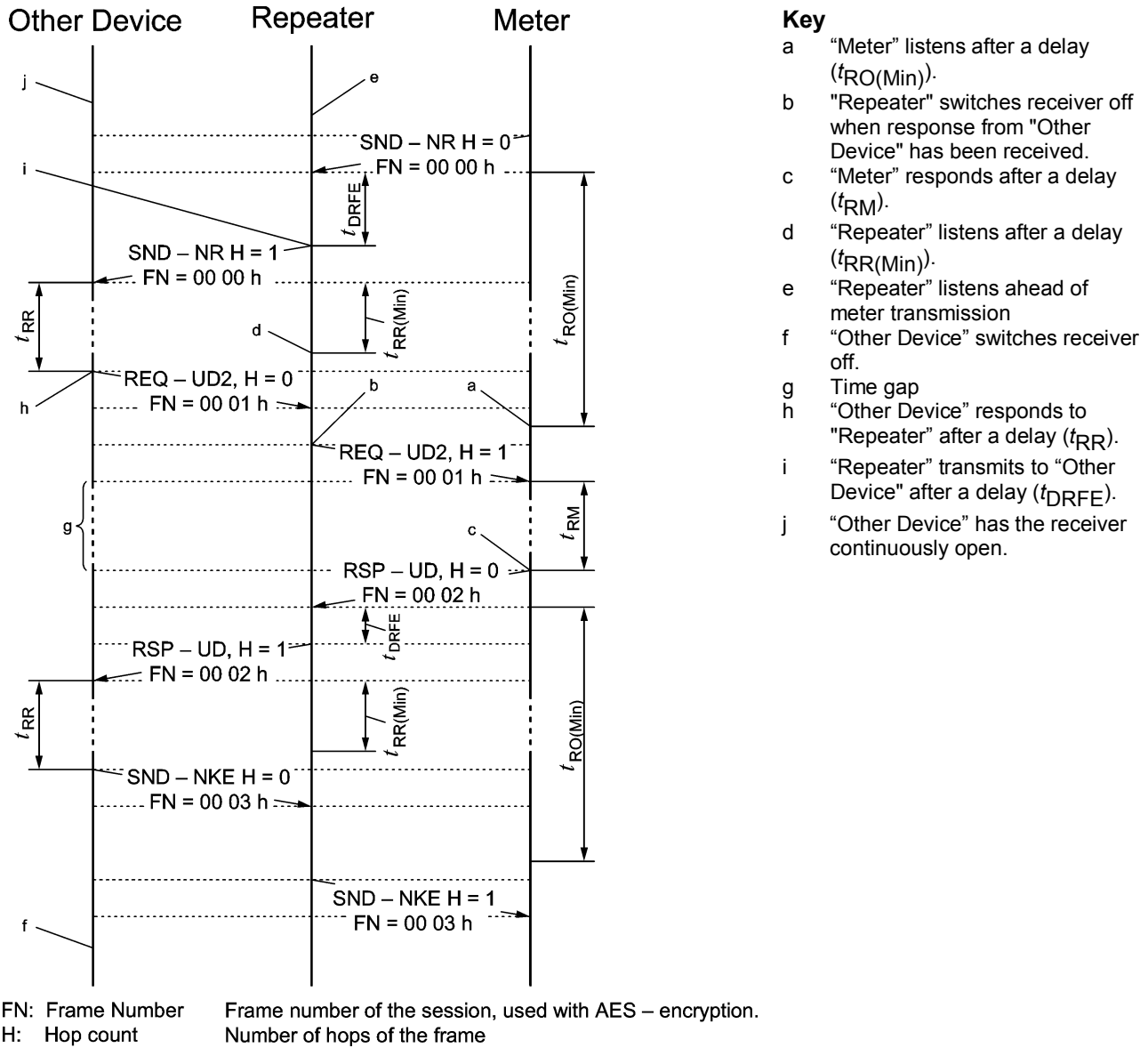

Figure E.9 — Mode C, transfer involving repeater

This figure emphasises how the parameters Frame number (FN) and Repeated (R) varies when data transfer with repeating is performed.

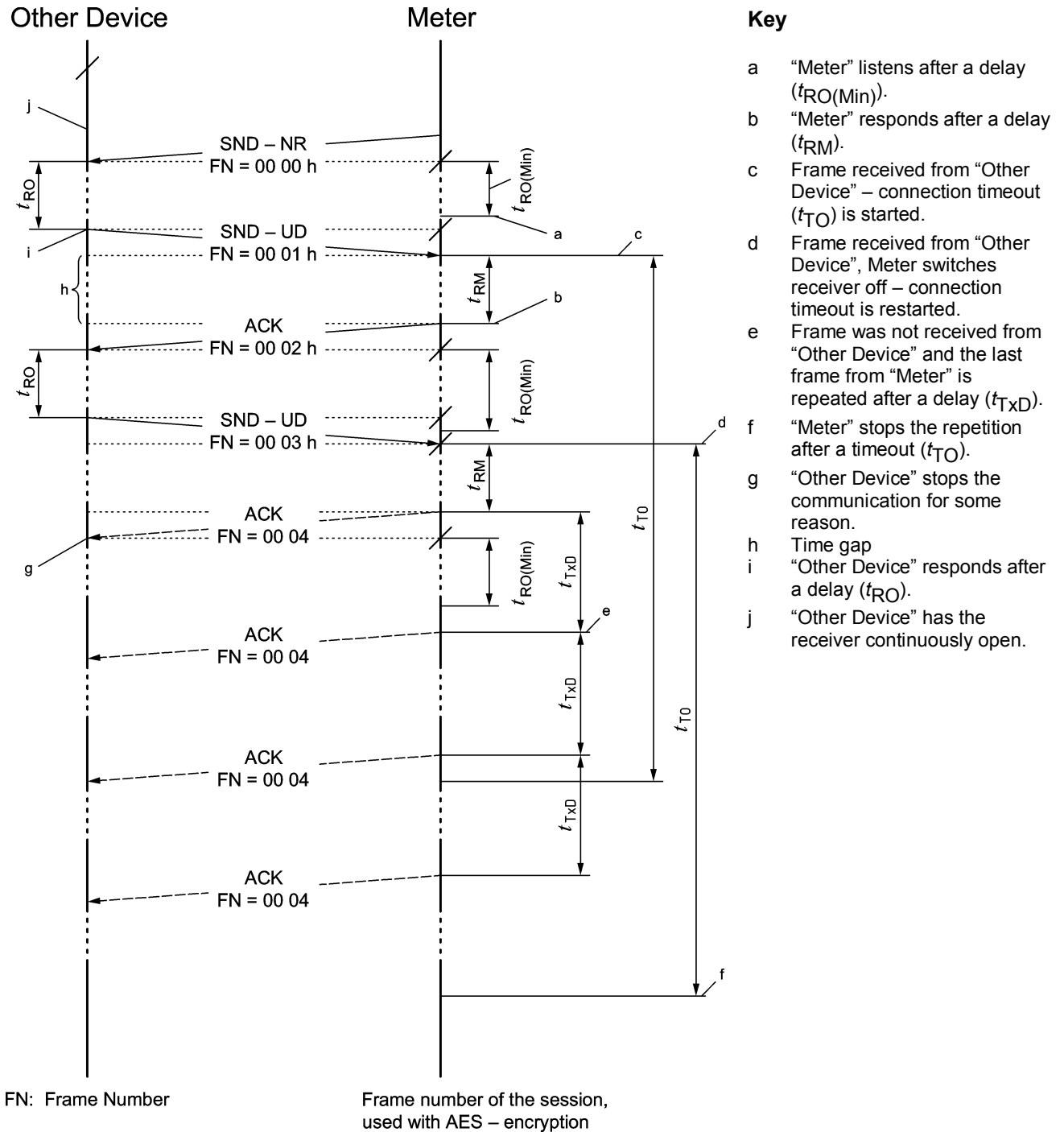
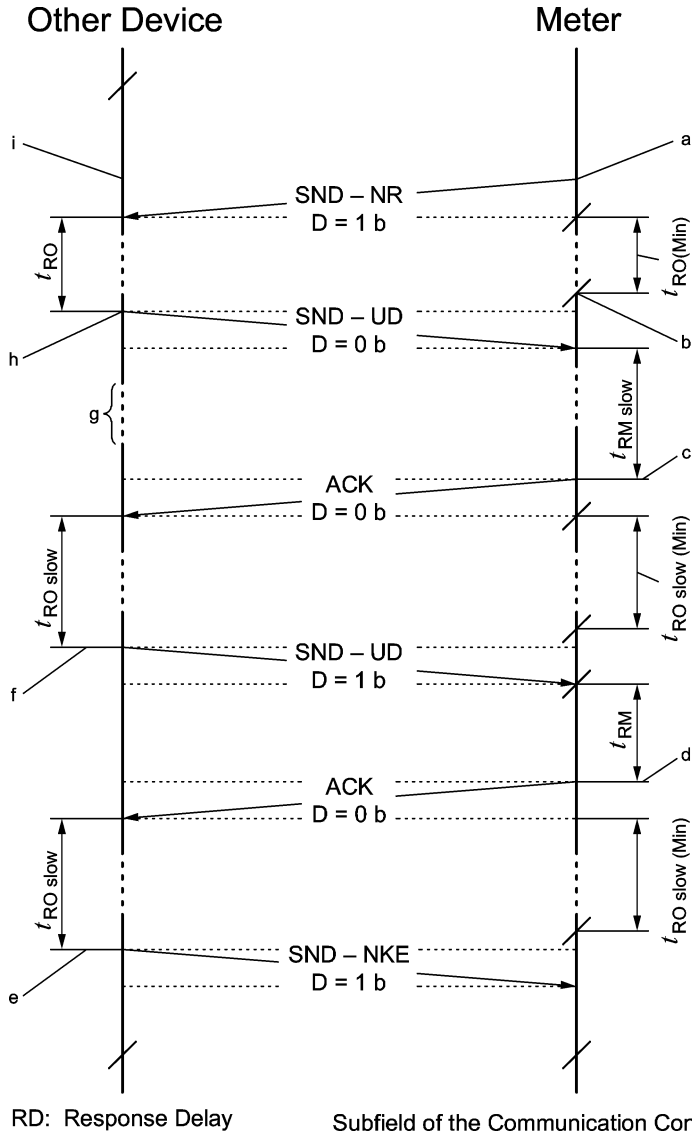

Figure E.10 — Mode C, using Frequent Access Cycle

This figure emphasises how the Frame number (FN) will vary when using the Frequent Access Cycle protocol.



Key

- a "Meter" transmits a frame specifying fast timing ($D = 1$).
- b "Meter" listens after a default delay ($t_{RO(Min)}$).
- c "Meter" responds after a slow delay ($t_{RM\ slow}$) since $D = 0$ in the received frame. When "Meter" receives a frame with $D = 0$ it shall also use $D = 0$ in the next frame.
- d "Meter" responds after a fast delay (t_{RM}) since $D = 1$ in the received frame. When "meter" receives a frame with $D = 1$ it is free to specify fast or slow timing.
- e "Other Device" responds after a slow delay ($t_{RO\ slow}$) since $D = 0$ in the received frame.
- f "Other Device" responds after a slow delay ($t_{RO\ slow}$) since $D = 0$ in the received frame. "Other Device" is always free to specify fast or slow timing.
- g Time gap
- h "Other Device" responds after a fast delay (t_{RO}) since $D = 1$ in the received frame.
- i "Other Device" has the receiver continuously open.

Figure E.11 — Mode C, fast or slow response delay

Annex F (informative)

Counter Mode Flow

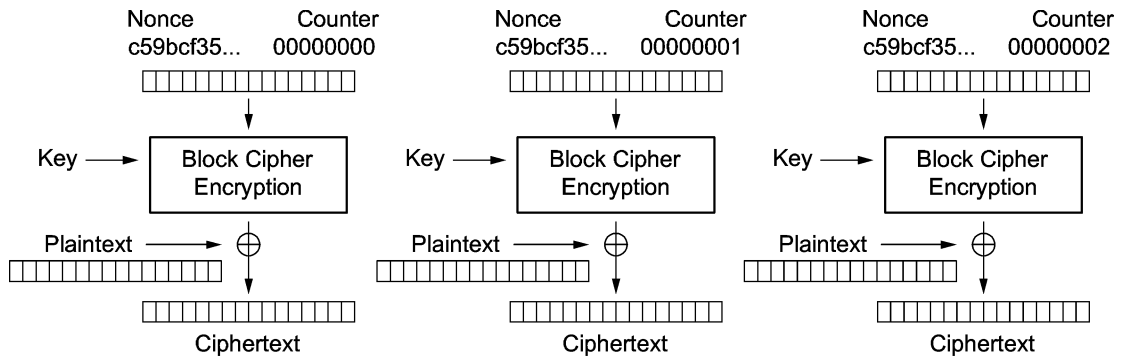

Counter (CTR) mode encryption

Figure F.1 — AES (128) counter mode encryption flow

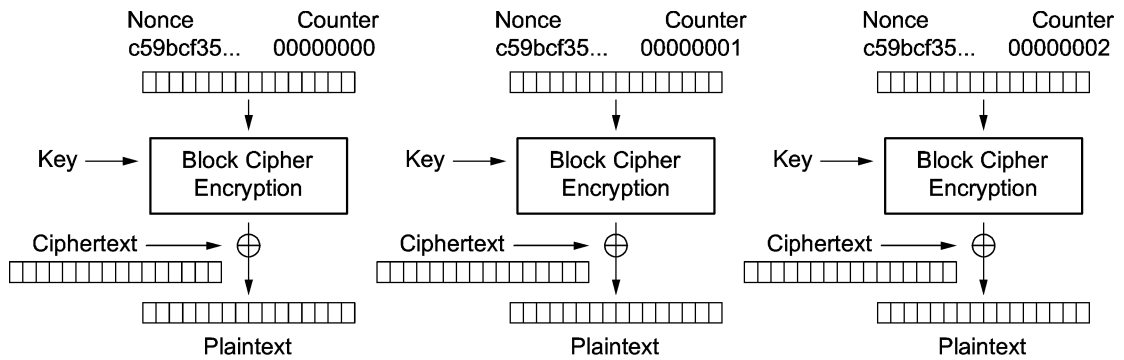

Counter (CTR) mode decryption

Figure F.2 — AES (128) counter mode decryption flow

Annex G (informative)

Structure of Extended Link Layer

In this annex, examples of the four different structures of the Link Layer Extensions are given.

CI-field = 8C_h

This value of the CI-field is used if data encryption at the link layer is not used in the frame. Figure G.1 below shows the complete extension block in this case.

| CI-field | CC-field | ACC-field |
|-----------------|----------|-----------|
| 8C _h | 1 byte | 1 byte |

Figure G.1 — Extended Link Layer with CI = 8C_h

CI-field = 8D_h

This value of the CI-field is used if data encryption at the link layer is used in the frame. Figure G.2 below shows the complete extension block in this case.

| CI-field | CC-field | ACC-field | SN-field | Payload CRC-field |
|-----------------|----------|-----------|----------|-------------------|
| 8D _h | 1 byte | 1 byte | 4 bytes | 2 bytes |

Figure G.2 — Extended Link Layer with CI = 8D_h

CI-field = 8E_h

This value of the CI-field is used if data encryption at the link layer is not used in the frame. This extended link layer specifies the receiver address. Figure G.3 below shows the complete extension block in this case.

| CI-field | CC-field | ACC-field | M2-field | A2-field |
|-----------------|----------|-----------|----------|----------|
| 8E _h | 1 byte | 1 byte | 2 bytes | 6 bytes |

Figure G.3 — Extended Link Layer with CI = 8E_h

CI-field = 8F_h

This value of the CI-field is used if data encryption at the link layer is used in the frame. This extended link layer specifies the receiver address. Figure G.4 below shows the complete extension block in this case.

| CI-field | CC-field | ACC-field | M2-field | A2-field | SN-field | Payload CRC-field |
|-----------------|----------|-----------|----------|----------|----------|-------------------|
| 8F _h | 1 byte | 1 byte | 2 bytes | 6 bytes | 4 bytes | 2 bytes |

Figure G.4 — Extended Link Layer with CI = 8F_h

Bibliography

- [1] EN 13757-2, *Communication systems for and remote control reading of meters — Part 2: Physical and link layer*
- [2] EN 13757-5, *Communication systems for meters and remote reading of meters — Part 5: Wireless relaying*
- [3] EN 62056-53, *Electricity metering — Data exchange for meter reading, tariff and load control — Part 53: COSEM application layer (IEC 62056-53)*
- [4] *Directive 1999/5/EC of the European Parliament and of the Council of 9 March 1999 on radio equipment and telecommunications terminal equipment and the mutual recognition of their conformity*
- [5] *COMMISSION DECISION of 20 December 2005 on the harmonisation of the 169,4-169,8125 MHz frequency band in the Community (notified under document number C(2005) 5003 (2005/928/EC)*
- [6] *COMMISSION DECISION of 9 November 2006 on harmonisation of the radio spectrum for use by short range devices (notified under document number C(2006) 5304) 2006/771/EC with amendments 2008/432/EC and 2009/381/EC*
- [7] CEN-CLC-ETSI TR 50572:2011, *Functional reference architecture for communications in smart metering systems*
- [8] ITU-T Rec. O.150 (05/96), *General requirements for instrumentation for performance measurements on digital transmission equipment*
- [9] NIST, FIPS PUB 197, *Advanced Encryption Standard (AES), November 2001*
- [10] NIST, SP800-38A, *Recommendation for Block Cipher Modes of Operation: Methods and Techniques, December 2001*

British Standards Institution (BSI)

BSI is the national body responsible for preparing British Standards and other standards-related publications, information and services.

BSI is incorporated by Royal Charter. British Standards and other standardization products are published by BSI Standards Limited.

About us

We bring together business, industry, government, consumers, innovators and others to shape their combined experience and expertise into standards-based solutions.

The knowledge embodied in our standards has been carefully assembled in a dependable format and refined through our open consultation process. Organizations of all sizes and across all sectors choose standards to help them achieve their goals.

Information on standards

We can provide you with the knowledge that your organization needs to succeed. Find out more about British Standards by visiting our website at bsigroup.com/standards or contacting our Customer Services team or Knowledge Centre.

Buying standards

You can buy and download PDF versions of BSI publications, including British and adopted European and international standards, through our website at bsigroup.com/shop, where hard copies can also be purchased.

If you need international and foreign standards from other Standards Development Organizations, hard copies can be ordered from our Customer Services team.

Subscriptions

Our range of subscription services are designed to make using standards easier for you. For further information on our subscription products go to bsigroup.com/subscriptions.

With **British Standards Online (BSOL)** you'll have instant access to over 55,000 British and adopted European and international standards from your desktop. It's available 24/7 and is refreshed daily so you'll always be up to date.

You can keep in touch with standards developments and receive substantial discounts on the purchase price of standards, both in single copy and subscription format, by becoming a **BSI Subscribing Member**.

PLUS is an updating service exclusive to BSI Subscribing Members. You will automatically receive the latest hard copy of your standards when they're revised or replaced.

To find out more about becoming a BSI Subscribing Member and the benefits of membership, please visit bsigroup.com/shop.

With a **Multi-User Network Licence (MUNL)** you are able to host standards publications on your intranet. Licences can cover as few or as many users as you wish. With updates supplied as soon as they're available, you can be sure your documentation is current. For further information, email bsmusales@bsigroup.com.

BSI Group Headquarters

389 Chiswick High Road London W4 4AL UK

Revisions

Our British Standards and other publications are updated by amendment or revision.

We continually improve the quality of our products and services to benefit your business. If you find an inaccuracy or ambiguity within a British Standard or other BSI publication please inform the Knowledge Centre.

Copyright

All the data, software and documentation set out in all British Standards and other BSI publications are the property of and copyrighted by BSI, or some person or entity that owns copyright in the information used (such as the international standardization bodies) and has formally licensed such information to BSI for commercial publication and use. Except as permitted under the Copyright, Designs and Patents Act 1988 no extract may be reproduced, stored in a retrieval system or transmitted in any form or by any means – electronic, photocopying, recording or otherwise – without prior written permission from BSI. Details and advice can be obtained from the Copyright & Licensing Department.

Useful Contacts:

Customer Services

Tel: +44 845 086 9001

Email (orders): orders@bsigroup.com

Email (enquiries): cservices@bsigroup.com

Subscriptions

Tel: +44 845 086 9001

Email: subscriptions@bsigroup.com

Knowledge Centre

Tel: +44 20 8996 7004

Email: knowledgecentre@bsigroup.com

Copyright & Licensing

Tel: +44 20 8996 7070

Email: copyright@bsigroup.com



...making excellence a habit.™