

# **Non-active medical devices — Test methods for primary wound dressings —**

## **Part 6: Odour control**

The European Standard EN 13726-6:2003 has the status of a  
British Standard

ICS 11.120.20

## National foreword

This British Standard is the official English language version of EN 13726-6:2003.

The UK participation in its preparation was entrusted by Technical Committee CH/205, Non-active medical devices, to Subcommittee CH/205/1, Medical textiles, which has the responsibility to:

- aid enquirers to understand the text;
- present to the responsible international/European committee any enquiries on the interpretation, or proposals for change, and keep the UK interests informed;
- monitor related international and European developments and promulgate them in the UK.

A list of organizations represented on this subcommittee can be obtained on request to its secretary.

### Cross-references

The British Standards which implement international or European publications referred to in this document may be found in the *BSI Catalogue* under the section entitled "International Standards Correspondence Index", or by using the "Search" facility of the *BSI Electronic Catalogue* or of British Standards Online.

This publication does not purport to include all the necessary provisions of a contract. Users are responsible for its correct application.

**Compliance with a British Standard does not of itself confer immunity from legal obligations.**

This British Standard was published under the authority of the Standards Policy and Strategy Committee on 13 May 2003

### Summary of pages

This document comprises a front cover, an inside front cover, the EN title page, pages 2 to 8, an inside back cover and a back cover.

The BSI copyright date displayed in this document indicates when the document was last issued.

### Amendments issued since publication

Amd. No.	Date	Comments

ICS 11.120.20

English version

**Non-active medical devices - Test methods for primary wound  
dressing - Part 6: Odour control**

Dispositifs médicaux non-actifs - Méthodes d'essai pour les  
pansements primaires en contact avec la plaie - Partie 6:  
Contrôle de l'odeur

Nichtaktive Medizinprodukte - Prüfverfahren für primäre  
Verbandstoffe (Wundauflagen) - Teil 6: Geruchsbindung

This European Standard was approved by CEN on 28 February 2003.

CEN members are bound to comply with the CEN/CENELEC Internal Regulations which stipulate the conditions for giving this European Standard the status of a national standard without any alteration. Up-to-date lists and bibliographical references concerning such national standards may be obtained on application to the Management Centre or to any CEN member.

This European Standard exists in three official versions (English, French, German). A version in any other language made by translation under the responsibility of a CEN member into its own language and notified to the Management Centre has the same status as the official versions.

CEN members are the national standards bodies of Austria, Belgium, Czech Republic, Denmark, Finland, France, Germany, Greece, Hungary, Iceland, Ireland, Italy, Luxembourg, Malta, Netherlands, Norway, Portugal, Slovakia, Spain, Sweden, Switzerland and United Kingdom.



EUROPEAN COMMITTEE FOR STANDARDIZATION  
COMITE EUROPEEN DE NORMALISATION  
EUROPAISCHES KOMITEE FÜR NORMUNG

Management Centre: rue de Stassart, 36 B-1050 Brussels

---

## Contents

page

Foreword.....	3
Introduction.....	4
1 <b>Scope.....</b>	<b>5</b>
2 <b>Terms and definitions.....</b>	<b>5</b>
3 <b>Test method for odour penetration.....</b>	<b>5</b>
3.1 <b>Significance and use.....</b>	<b>5</b>
3.2 <b>Equipment.....</b>	<b>5</b>
3.3 <b>Procedure.....</b>	<b>6</b>
3.4 <b>Results.....</b>	<b>7</b>
3.5 <b>Test report.....</b>	<b>7</b>

## Foreword

This document (EN 13726-6:2003) has been prepared by Technical Committee CEN /TC 205, "Non-active medical devices", the secretariat of which is held by BSI.

This European Standard shall be given the status of a national standard, either by publication of an identical text or by endorsement, at the latest by October 2003, and conflicting national standards shall be withdrawn at the latest by October 2003.

EN 13726 consists of the following Parts under the general title *Non-active medical devices - Test methods for primary wound dressings*:

*Part 1: Aspects of absorbency*

*Part 2: Moisture vapour transmission rate of permeable film dressings*

*Part 3: Waterproofness*

*Part 4: Conformability*

*Part 5: Bacterial barrier properties*

*Part 6: Odour control*

According to the CEN/CENELEC Internal Regulations, the national standards organizations of the following countries are bound to implement this European Standard: Austria, Belgium, Czech Republic, Denmark, Finland, France, Germany, Greece, Hungary, Iceland, Ireland, Italy, Luxembourg, Malta, Netherlands, Norway, Portugal, Slovakia, Spain, Sweden, Switzerland and the United Kingdom.

## Introduction

EN 13726 gives test methods and does not contain performance requirements. EN 13726-6 describes a test method for odour control of primary wound dressings.

Test methods for other aspects of primary wound dressings are described in other parts of EN 13726.

## 1 Scope

This European Standard describes a test method for the evaluation of the resistance of primary wound dressings to penetration by odour.

## 2 Terms and definitions

For the purposes of this European Standard, the following terms and definitions apply:

### 2.1

#### **primary wound dressing**

material or combination of materials, in any shape, form or size that is intended to remain in direct contact with a wound

**NOTE** Primary wound dressing are used as mechanical barriers, for the absorption or transmission of exudates, to manage the micro-environment of the wound, and can enable the wound to heal by primary or secondary intent. Devices which have a metabolic, pharmacological or immunological interaction as their primary intent are excluded.

## 3 Test method for odour penetration

### 3.1 Significance and use

This test is designed to assess the resistance of primary wound dressings to penetration by odours. It only applies to dressings of a design where the odour absorbing material is not penetrated by exudate.

### 3.2 Equipment

**3.2.1** Gas chromatograph (GC), capable of taking a packed column and running under the following conditions:

- Injector temperature : 300 °C;
- Oven temperature : 250 °C;
- Detector temperature : 300 °C;
- N<sub>2</sub> Flow rate : 40 ml/min;
- Detection : Flame Ionization Detector

## EN 13726-6:2003 (E)

- 3.2.2 Packed GC column, 10 % OV-17 (or similar that provides no obstruction to the gaseous sample).
- 3.2.3 Sealable stainless steel (grade 316) sample vessel, (of known volume) with sealed injection/sampling port (see Figure 1).
- 3.2.4 Suitable gaskets (material: PTFE).
- 3.2.5 500 µl gas-tight syringe.
- 3.2.6 Oven capable of being set at 105 °C.
- 3.2.7 Oven capable of being set at 37 °C.
- 3.2.8 1 µl syringe.
- 3.2.9 Balance readable to 0,001 g.

### 3.3 Procedure

#### 3.3.1 Control Preparation

- 3.3.1.1 Condition the sample vessel for approximately 1 h at 105 °C to remove any trace compounds.
- 3.3.1.2 Place a gasket between the two parts of the vessel.
- 3.3.1.3 Purge the complete vessel with nitrogen through the injection/sampling port and seal the port with an appropriate septum.
- 3.3.1.4 Inject 0,5 µl of pure (> 99,7 %) diethylamine into the vessel through the septum, and place into a 37 °C oven for approximately 20 min.
- 3.3.1.5 Remove a 250 µl sample of gas, taking care to pump the syringe twice before withdrawing the plunger to 500 µl for approximately 10 s and returning to the 250 µl position. Inject this sample slug into the GC. Repeat gaseous sample extraction twice.
- 3.3.1.6 Use the average of the peak areas as the cut-off limit.

#### 3.3.2 Sample Preparation

- 3.3.2.1 Condition the sample vessel for approximately 1 h at 105 °C to remove any trace compounds.
- 3.3.2.2 Make up a 1,3 % w/v solution of diethylamine in water.
- 3.3.2.3 Place (20,0 ± 0,5) ml of the solution into the lower part of the vessel..
- 3.3.2.4 Place a gasket and an appropriate size of dressing with the wound contact side facing down over the lower part of the vessel.
- 3.3.2.5 Purge the top half of the vessel with nitrogen (20 kPa) through the injection/sampling port, for at least 100 s. Seal the top half in place whilst purging, using the second gasket. Remove the purge line and seal the sample port with an appropriate septum.
- 3.3.2.6 Remove an initial 250 nl sample of gas, taking care to pump the syringe twice before withdrawing the plunger to 500 µl for approximately 10 s and returning to the 250 µl position. Inject this sample of gas into the GC.



**3.3.2.7** Place the sample vessel into a 37 °C oven, and repeat 3.3.2.6 at appropriate intervals, adequate to determine the time to achieve 6ppm with an accuracy of 10 %, depending on the sample type. Repeat until the peak area of the control is exceeded.

### **3.4 Results**

All results shall be quoted as time taken for the atmosphere inside the upper half vessel to reach a concentration of 6 ppm of diethylamine.

### **3.5 Test report**

The report shall include at least the following information:

- a) type of dressing, including lot number;
- b) any deviations from the test method;
- c) the result of the test;
- d) date of test;
- e) identity of the person(s) who carried out the test.

Dimensions in millimetres

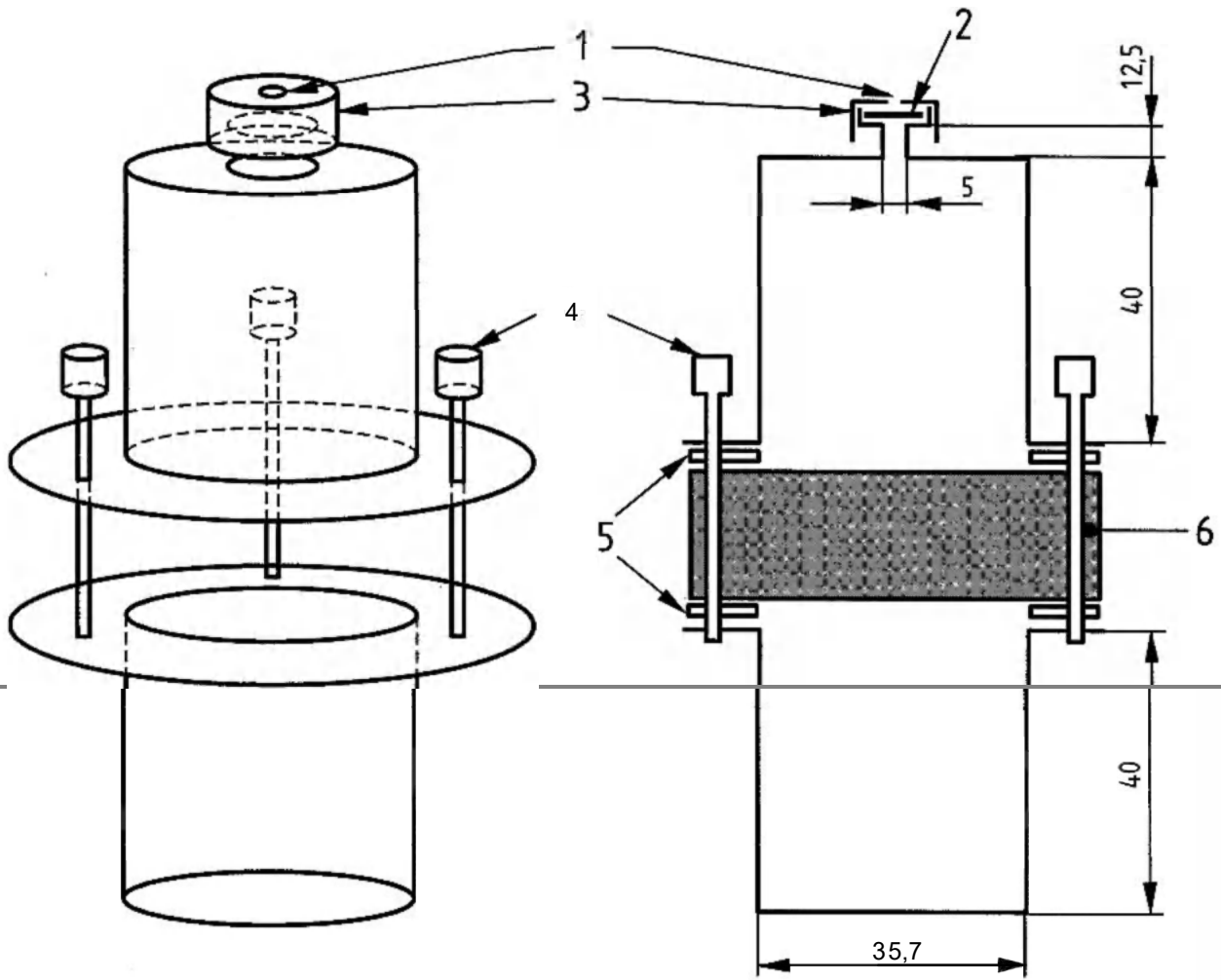

**Key**

- 1 Injection/sampling port
- 2 Septum
- 3 Screw cap
- 4 Securing bolts
- 5 Gaskets
- 6 Sample

**Figure 1 — Sealable stainless steel test vessel**



---

---

## **BSI — British Standards Institution**

BSI is the independent national body responsible for preparing British Standards. It presents the UK view on standards in Europe and at the international level. It is incorporated by Royal Charter.

### **Revisions**

British Standards are updated by amendment or revision. Users of British Standards should make sure that they possess the latest amendments or editions.

It is the constant aim of BSI to improve the quality of our products and services. We would be grateful if anyone finding an inaccuracy or ambiguity while using this British Standard would inform the Secretary of the technical committee responsible, the identity of which can be found on the inside front cover.  
Tel: +44 (0)20 8996 9000. Fax: +44 (0)20 8996 7400.

BSI offers members an individual updating service called PLUS which ensures that subscribers automatically receive the latest editions of standards.

### **Buying standards**

Orders for all BSI, international and foreign standards publications should be addressed to Customer Services. Tel: +44 (0)20 8996 9001.  
Fax: +44 (0)20 8996 7001. Email: [orders@bsi-global.com](mailto:orders@bsi-global.com). Standards are also available from the BSI website at <http://www.bsi-global.com>.

In response to orders for international standards, it is BSI policy to supply the BSI implementation of those that have been published as British Standards, unless otherwise requested.

### **Information on standards**

BSI provides a wide range of information on national, European and international standards through its Library and its Technical Help to Exporters Service. Various BSI electronic information services are also available which give details on all its products and services. Contact the Information Centre.  
Tel: +44 (0)20 8996 7111. Fax: +44 (0)20 8996 7048. Email: [info@bsi-global.com](mailto:info@bsi-global.com).

Subscribing members of BSI are kept up to date with standards developments and receive substantial discounts on the purchase price of standards. For details of these and other benefits contact Membership Administration.  
Tel: +44 (0)20 8996 7002. Fax: +44 (0)20 8996 7001.  
Email: [membership@bsi-global.com](mailto:membership@bsi-global.com).

Information regarding online access to British Standards via British Standards Online can be found at <http://www.bsi-global.com/bsonline>.

Further information about BSI is available on the BSI website at <http://www.bsi-global.com>.

### **Copyright**

Copyright subsists in all BSI publications. BSI also holds the copyright, in the UK, of the publications of the international standardization bodies. Except as permitted under the Copyright, Designs and Patents Act 1988 no extract may be reproduced, stored in a retrieval system or transmitted in any form or by any means — electronic, photocopying, recording or otherwise — without prior written permission from BSI.

This does not preclude the free use, in the course of implementing the standard, of necessary details such as symbols, and size, type or grade designations. If these details are to be used for any other purpose than implementation then the prior written permission of BSI must be obtained.

Details and advice can be obtained from the Copyright & Licensing Manager.  
Tel: +44 (0)20 8996 7070. Fax: +44 (0)20 8996 7553.  
Email: [copyright@bsi-global.com](mailto:copyright@bsi-global.com).