

# Railway applications — Wheelsets and bogies — Wheels — Wheels tread

The European Standard EN 13715:2006 has the status of a  
British Standard

ICS 45.040

## National foreword

This British Standard is the official English language version of EN 13715:2006.

The UK participation in its preparation was entrusted by Technical Committee RAE/3, Railway rolling stock materials, to Subcommittee RAE/3/-/1, Wheels and wheelsets, which has the responsibility to:

- aid enquirers to understand the text;
- present to the responsible international/European committee any enquiries on the interpretation, or proposals for change, and keep UK interests informed;
- monitor related international and European developments and promulgate them in the UK.

A list of organizations represented on this subcommittee can be obtained on request to its secretary.

### Cross-references

The British Standards which implement international or European publications referred to in this document may be found in the *BSI Catalogue* under the section entitled “International Standards Correspondence Index”, or by using the “Search” facility of the *BSI Electronic Catalogue* or of British Standards Online.

This publication does not purport to include all the necessary provisions of a contract. Users are responsible for its correct application.

**Compliance with a British Standard does not of itself confer immunity from legal obligations.**

### Summary of pages

This document comprises a front cover, an inside front cover, the EN title page, pages 2 to 29 and a back cover.

The BSI copyright notice displayed in this document indicates when the document was last issued.

### Amendments issued since publication

Amd. No.	Date	Comments
16515 Corrigendum No. 1	30 June 2006	Correction to formatting errors at printing stage

This British Standard was published under the authority of the Standards Policy and Strategy Committee on 31 March 2006

© BSI 2006

ISBN 0 580 48002 X

EUROPEAN STANDARD

**EN 13715**

NORME EUROPÉENNE

EUROPÄISCHE NORM

February 2006

---

ICS 45.040

English Version

## Railway applications - Wheelsets and bogies - Wheels - Wheels tread

Applications ferroviaires - Essieux montés et bogies -  
Roues - Profil de roulement

Bahnwendungen - Radsätze und Drehgestelle - Räder -  
Radprofile

This European Standard was approved by CEN on 9 January 2006.

CEN members are bound to comply with the CEN/CENELEC Internal Regulations which stipulate the conditions for giving this European Standard the status of a national standard without any alteration. Up-to-date lists and bibliographical references concerning such national standards may be obtained on application to the Central Secretariat or to any CEN member.

This European Standard exists in three official versions (English, French, German). A version in any other language made by translation under the responsibility of a CEN member into its own language and notified to the Central Secretariat has the same status as the official versions.

CEN members are the national standards bodies of Austria, Belgium, Cyprus, Czech Republic, Denmark, Estonia, Finland, France, Germany, Greece, Hungary, Iceland, Ireland, Italy, Latvia, Lithuania, Luxembourg, Malta, Netherlands, Norway, Poland, Portugal, Romania, Slovakia, Slovenia, Spain, Sweden, Switzerland and United Kingdom.



EUROPEAN COMMITTEE FOR STANDARDIZATION  
COMITÉ EUROPÉEN DE NORMALISATION  
EUROPÄISCHES KOMITEE FÜR NORMUNG

**Management Centre: rue de Stassart, 36 B-1050 Brussels**

## Contents

Page

Foreword.....	4
Introduction .....	4
<b>1 Scope .....</b>	<b>5</b>
<b>2 Normative references .....</b>	<b>5</b>
<b>3 Definition of the tread profile.....</b>	<b>5</b>
<b>4 Symbols and abbreviations .....</b>	<b>7</b>
<b>4.1 Definition of the profiles .....</b>	<b>8</b>
<b>5 Construction method .....</b>	<b>8</b>
<b>5.1 Definition of the axes .....</b>	<b>8</b>
<b>5.2 Base profile .....</b>	<b>8</b>
<b>5.3 Profile construction .....</b>	<b>8</b>
<b>5.3.1 Profile zone H2 – D1 (flange).....</b>	<b>8</b>
<b>5.3.2 Profile connection zone D1 – C1 .....</b>	<b>9</b>
<b>5.3.3 Profile zone D1 – C1 –D0 for flange thicknesses <math>28,5 \text{ mm} \leq e \leq 32,5 \text{ mm}</math> .....</b>	<b>10</b>
<b>5.3.4 Zone D0 – B1 (B1a or B1b).....</b>	<b>11</b>
<b>5.3.5 Reverse slope and chamfer .....</b>	<b>12</b>
<b>6 Geometric characteristics.....</b>	<b>12</b>
<b>6.1 R20,5 connecting radius .....</b>	<b>12</b>
<b>6.2 RE and RI 12 mm connecting radii.....</b>	<b>12</b>
<b>6.3 Rfa connecting radius .....</b>	<b>13</b>
<b>6.4 R13 connecting radius .....</b>	<b>13</b>
<b>6.5 Wheel tread.....</b>	<b>13</b>
<b>6.6 Reverse slope – Chamfer.....</b>	<b>13</b>
<b>7 Profile designation.....</b>	<b>13</b>
<b>8 Reference equipment for verification of the wheel profile .....</b>	<b>13</b>
<b>Annex A (normative) Flange .....</b>	<b>14</b>
<b>A.1 Definition of the flange.....</b>	<b>14</b>
<b>A.2 Flange geometry .....</b>	<b>15</b>
<b>Annex B (normative) 1/40th profile.....</b>	<b>16</b>
<b>B.1 Complete reference profile: construction with a 32,5 mm thick flange and 15 % reverse slope.....</b>	<b>16</b>
<b>B.2 Profile construction: specific zones .....</b>	<b>16</b>
<b>Annex C (normative) S1002 profile .....</b>	<b>18</b>
<b>C.1 Complete reference profile: construction with 32,5 mm thick flange and 6,7 % reverse slope.....</b>	<b>18</b>
<b>C.2 Profile construction: specific zones .....</b>	<b>18</b>
<b>Annex D (normative) EPS profile .....</b>	<b>22</b>
<b>D.1 Complete reference profile: construction with 32,5 mm thick flange and 10 % reverse slope.....</b>	<b>22</b>
<b>D.2 Profile construction: specific zones .....</b>	<b>22</b>
<b>Annex ZA (informative) Relationship between this European Standard and the Essential Requirements of EU Directive 96/48/EC .....</b>	<b>25</b>
<b>Annex ZB (informative) Relationship between this European Standard and the Essential Requirements of EU Directive 2001/16/EC .....</b>	<b>27</b>

**Bibliography.....29**

## Foreword

This document (EN 13715:2006) has been prepared by Technical Committee CEN/TC 256 "Railway applications", the secretariat of which is held by DIN.

This European Standard shall be given the status of a national standard, either by publication of an identical text or by endorsement, at the latest by August 2006, and conflicting national standards shall be withdrawn at the latest by August 2006.

This document has been prepared under a mandate given to CEN by the European Commission and the European Free Trade Association, and supports essential requirements of [EU Directives 96/48 and 2001/16](#).

For relationship with EU Directive(s), see informative Annexes [ZA](#) and [ZB](#), which are integral parts of this document.

According to the CEN/CENELEC Internal Regulations, the national standards organizations of the following countries are bound to implement this European Standard: Austria, Belgium, Cyprus, Czech Republic, Denmark, Estonia, Finland, France, Germany, Greece, Hungary, Iceland, Ireland, Italy, Latvia, Lithuania, Luxembourg, Malta, Netherlands, Norway, Poland, Portugal, Romania, Slovakia, Slovenia, Spain, Sweden, Switzerland and the United Kingdom.

## Introduction

This standard states requirements that are in accordance with the principles adopted by the International Union of Railways. It:

- describes the rules, parameters and construction methods of the wheel tread profile;
- defines the geometry of the flange and reverse slope. The thicknesses and height of the flange are determined by the railway undertaking or its representative in compliance with the normative documents in force;
- defines the co-ordinates and geometry of the following three reference tread profiles of the wheels and their reverse slope:
  - 1/40<sup>th</sup> (reverse slope 15 %);
  - S1002 (reverse slope 6,7 %, other value used 15 %) in conformity with UIC Leaflet 510-2;
  - EPS (reverse slope 10 %) equivalent to profile P8 of the United Kingdom with a flange 30 mm thick.

These three reference profiles are defined in Annexes B, C and D and represent original profiles from the time of their design, the flanges having been harmonized to a 32,5 mm flange thickness.

- defines the tolerances needed to achieve calibration control.

All the dimensions in this standard are given in millimetres.

**1 Scope**

This European Standard defines the tread profiles of wheels with a diameter greater than or equal to 330 mm used on vehicles running on European standard gauge track to fulfil interoperability requirements. These profiles apply to new wheels, whether free-standing or assembled as wheelsets, as well as to wheels that require reprofiling during maintenance.

Any profile that does not conform to this standard shall only be used following agreement between the train operator and the infrastructure manager.

**2 Normative references**

None apply to this standard.

**3 Definition of the tread profile**

The tread profile is shown in Figure 1.

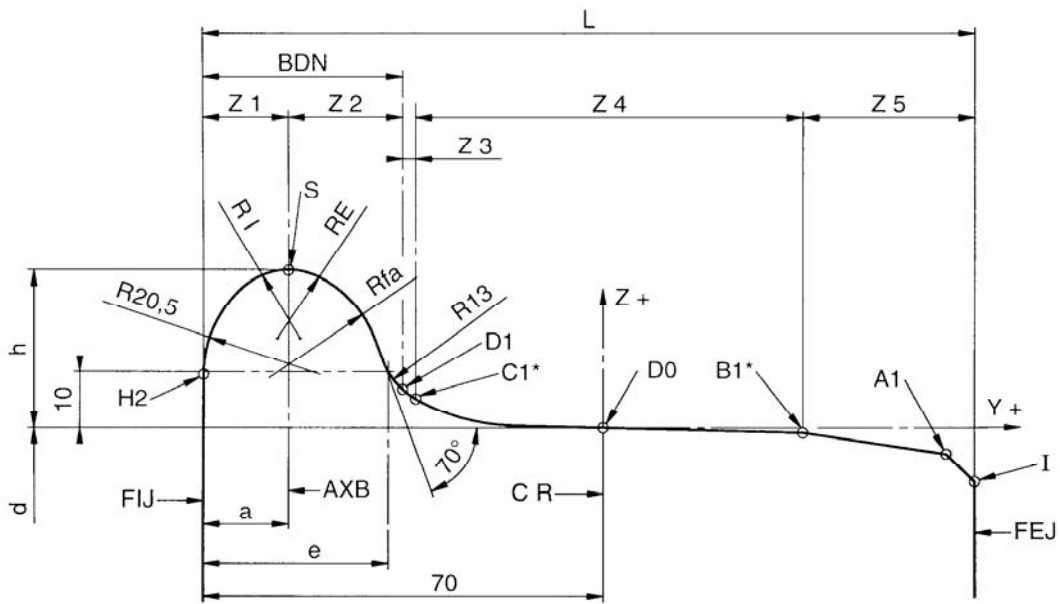

Key

**EN 13715:2006 (E)**

The points marked with "\*" relate respectively to the following profiles

- B 1 S1002
- B1a 1/40<sup>th</sup>
- B1b EPS
- C1 S1002
- C1a 1/40<sup>th</sup>
- C1b EPS

See Table 1 – Symbols and abbreviations

**Figure 1 – Wheel tread profile**



## 4 Symbols and abbreviations

**Table 1 — Symbols and abbreviations**

Z 1	Internal zone of flange (H2 – S)
Z 2	External zone of flange (S – D1)
Z 3	Connection zone, flange to wheel tread [D1 – C1(C1a, C1b)]
Z 4	Wheel tread zone [C1 (C1a, C1b) - B1 (B1a, B1b)]
Z 5	Zone between the wheel tread (reverse slope) and chamfer [B1 (B1a, B1b) – I]
a	Position of the axis intersecting the tip of the flange relative to the internal face of the wheel
d	Wheel diameter
e	Flange thickness
de	Difference between the reference value for flange thickness (32,5 mm) and the new value of "e"
h	Flange height
Y	Y axis
Z	Z axis
y	Abscissa according to "Y" axis for the specific point
z	Ordinate according to the "Z" axis for the specific point
A1	Connection point of the reverse slope with the 5 mm x 5 mm chamfer
B1 (B1a, B1b)	Connection point of the reverse slope with the wheel tread
C1 C1a, C1b)	Starting point of the connection zone between the wheel tread and the flange zone
C11a, C11b, C12, D1a, D1b, E1, F1, G1, H1, T1	Unique profile construction points
D0	Location of the wheel tread, 70 mm from its internal face. Origin of the co-ordinate axes
D1	Starting point of the flange
H2	Finishing point of the flange, on the internal face of the wheel
I	Starting point of the profile on the external face of the wheel
L	Rim nominal width, 135 mm or 140 mm
Rfa	External flange radius, a function of the flange height
RE	12 mm radius, connection to the external face of the flange
RI	12 mm radius, connection to the internal face of the flange
Rem	Centre of radius RE
Rim	Centre of radius RI
R13	13 mm radius, connection between the internal face of the flange and the wheel tread
Hm	Centre of 20,5 mm radius
Fm	Centre of Rfa radius
Dm	Centre of R 13 radius
Jm	Centre of 100 mm radius (EPS) and of 36 mm radius (1/40 <sup>th</sup> )
Jm1	Centre of 330 mm radius (EPS)
S	Connection at the tip of the flange
AXB	Connection axis at the tip of the flange
BDN	Flange
CR	Wheel tread plane
FEJ	External face of the wheel
FIJ	Internal face of the wheel

## 4.1 Definition of the profiles

The profiles comprise:

- two zones H2 – S and S – D1, with fixed geometry;
- a connection zone D1 – C1, unique to each of them, to make a tangential connection at point C1;
- a zone C1 – B1 (either B1a, or B1b) unique to each of them. The co-ordinates are given in Annexes B, C and D for the three reference profiles including point D0;
- a zone B1 (either B1a or B1b) – A1 – I, comprising the reverse slope and chamfer, unique to each reference profile. The reverse slope shall be in the range 6,7 % to 15 %.

## 5 Construction method

### 5.1 Definition of the axes

The Y axis is parallel to the axis of rotation of the wheel with the positive values towards the external face of the wheel. The Z axis is perpendicular to the latter with the positive values towards the outside of the wheel. Their origin is at point D0, situated 70 mm from the internal face of the wheel.

### 5.2 Base profile

The base profile is that obtained with a flange 32,5 mm thick and 28 mm high. All the others are developed from this fundamental profile.

### 5.3 Profile construction

#### 5.3.1 Profile zone H2 – D1 (flange)

The reference flange (dimensions, centres and radii) is given in Annex A for a flange thickness of 32,5 mm.

The different flange thicknesses are obtained by translating the zones S-D1, parallel to the Y axis, towards the internal face of the wheel. Annex A gives all the co-ordinates for flange thicknesses between 28,5 mm and 32,5 mm.

After translation, the connection axis (AXB) at the tip of the flange (S) is at a distance, in mm, from the wheel

internal face of:  $a = 15 - \left( \frac{32,5 - e}{2} \right)$

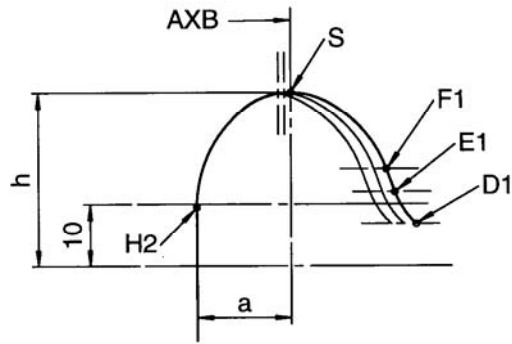

Figure 2 – Flange

5.3.2 Profile connection zone D1 – C1

The characteristics of these connections specific to each profile are given in Annexes B, C and D.

The definitions of the connection zones are shown in Figures 3, 4 and 5.

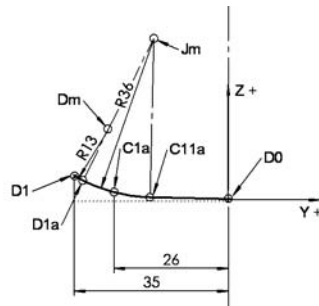

Figure 3 – 1/40<sup>th</sup> connection zone

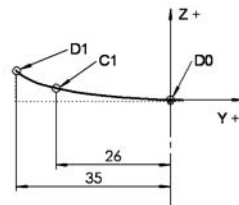

Figure 4 – S1002 connection zone

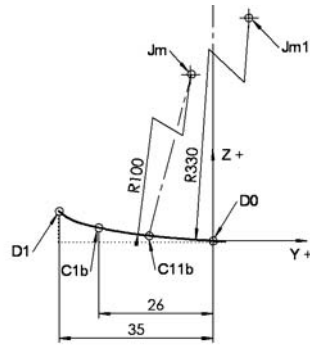

Figure 5 – EPS connection zone

5.3.3 Profile zone D1 – C1 –D0 for flange thicknesses  $28,5 \text{ mm} \leq e \leq 32,5 \text{ mm}$

5.3.3.1 S1002 and 1/40<sup>th</sup> profiles

For flange thicknesses greater than 28,5 mm, but less than 32,5 mm, the profiles are obtained by translating the zones D1-C1 (connection zone) and C1-T1 along the Y axis towards the internal face of the wheel, by an amount equal to the reduction (de) in thickness of the flange.

The position of the point T1 is defined relative to the reference point D0 for all flange thicknesses.

The connection between points D0 and T1 may be smoothed by a straight line.

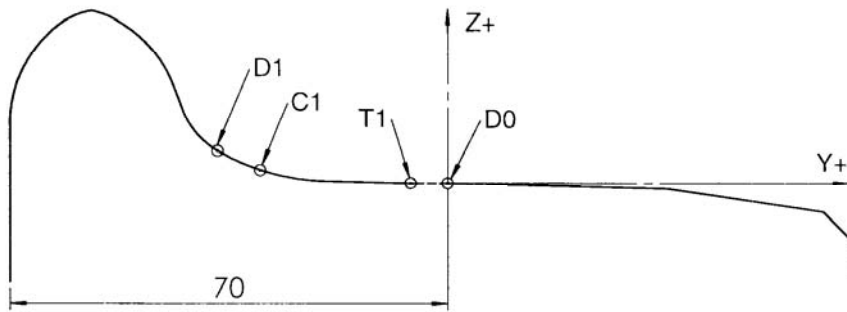

Figure 6 – Extension of the wheel tread zone T1 – D0

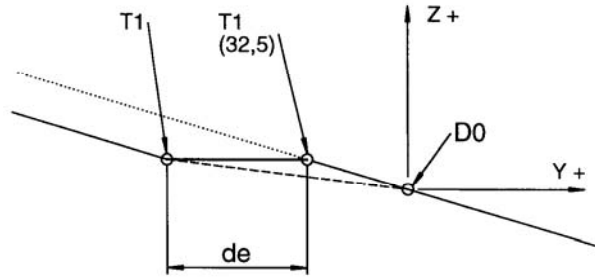

Figure 7 – Connection T1 – D0

5.3.3.2 EPS profile

For the flange thickness values greater than 28,5 mm and less than 32,5 mm, the profile shape is obtained by changing a curve in zone D1-C1, the co-ordinates of which are given in Table D.1 which defines the EPS profile in Annex D (the centre of the 330 mm radius remains fixed).

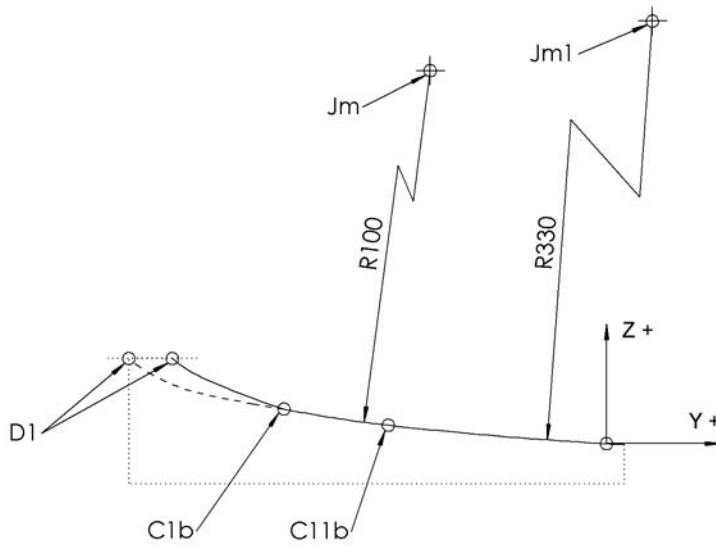

Figure 8 – EPS profile

5.3.4 Zone D0 – B1 (B1a or B1b)

The zone D0 – B1 (B1a or B1b), as appropriate to each profile, remains fixed for each type.

### 5.3.5 Reverse slope and chamfer

The point B1 of the S1002 profile at the beginning of the reverse slope after the wheel tread is always situated at 102 mm, 158 mm from the internal face of the wheel. The positions of points B1a and B1b of the 1/40<sup>th</sup> and EPS profiles relative to point B1 are shown below.

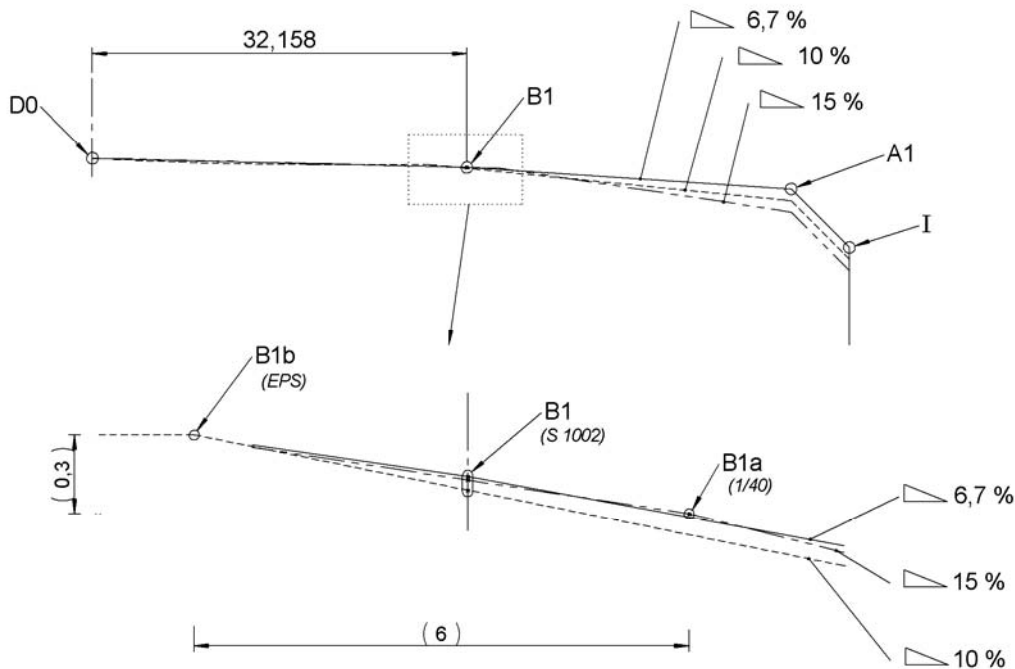

Figure 9 – Reverse slope and chamfer

The reverse slope profile connects with the wheel tread at point B1 (S1002 profile), B1a (1/40<sup>th</sup> profile) and B1b (EPS profile).

## 6 Geometric characteristics

### 6.1 R20,5 connecting radius

The co-ordinates of the centre Hm of the R20,5 radius are given in Annex A.

### 6.2 RE and RI 12 mm connecting radii

The co-ordinates of the RE<sub>m</sub> and RI<sub>m</sub> centres of the RE and RI radii, are defined relative to DO as follows:

$$zRE_m \text{ and } zRI_m = (\text{flange height} - 12) \text{ mm.}$$

These co-ordinates are given in Annex A.

### 6.3 Rfa connecting radius

The values of the Rfa connecting radius as a function of the flange height are given in Table 2.

**Table 2 — Rfa connecting radius**

Minimum flange height ( <i>h</i> )	Radius (Rfa)
28	20
30	21,5
32	23

### 6.4 R13 connecting radius

The co-ordinates of the centre Dm of the R13 radius are given in Annex A.

### 6.5 Wheel tread

This is defined in Annexes B, C, and D for each of the profile types.

### 6.6 Reverse slope – Chamfer

The reverse slope shall have a uniform gradient between 6,7 % and 15 % and shall terminate with a 5 mm x 5 mm chamfer.

## 7 Profile designation

The profile is designated as follows: "EN 13715 – profile type/flange height/flange thickness/value of the reverse slope used".

The profile type is the reference profile given in Annex B, C or D.

Examples:

- **EN 13715 – 1/40/h28/e30,5/15%** (profile derived from the 1/40<sup>th</sup> reference profile, conforming to EN 13715, with a flange 28 mm high, 30,5 mm thick and a 15 % reverse slope);
- **EN 13715 – S 1002/h30/e30/15%** (profile derived from the S 1002 reference profile, conforming to EN 13715, with a flange 30 mm high, 30 mm thick and a 15 % reverse slope);
- **EN 13715 – EPS/h32/e28,5/10%** (profile derived from the EPS reference profile, conforming to EN 13715, with a flange 32 mm high, 28,5 mm thick and a 10 % reverse slope).

## 8 Reference equipment for verification of the wheel profile

The standard gauge is verified using equipment metrologically linked to a national metrology body.

A standard gauge is made with a tolerance of  $\pm 0,025$  mm relative to the theoretical profile. A working gauge shall be made with a tolerance of  $\leq 0,06$  mm relative to the standard gauge

Any other methods of verification, to an equivalent level, may be used after having been qualified by a recognized body.

# Annex A (normative)

## Flange

### A.1 Definition of the flange

The points defining the flange are shown in Figure A.1.

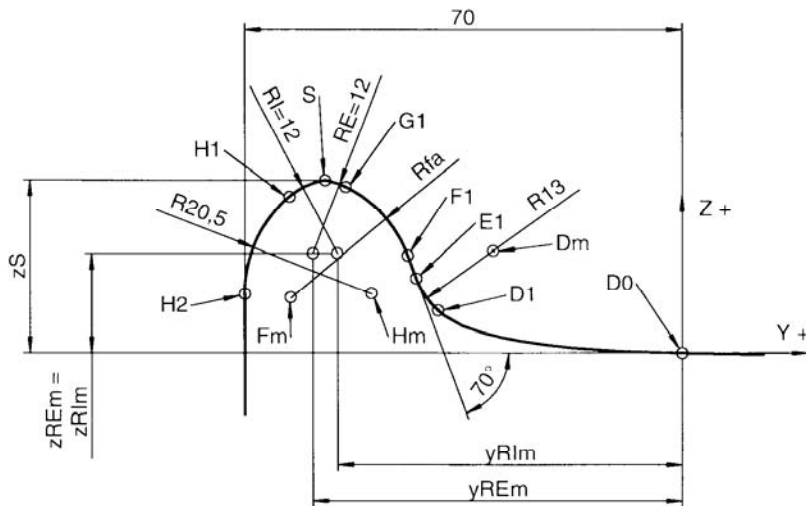

Figure A.1 – Definition of the flange



## A.2 Flange geometry

Table A.1 – Co-ordinates of the flange points as a function of its thickness

		D1 → H2					
P	e	yP		zP			
D1	e=32,5	-35		6,867			
	e	- 35 - de					
	e=28,5	-39					
E1	e=32,5	-38,427		12			
	e	- 38,427 - de					
	e=28,5	-42,427					
Dm	e=32,5	-26,211		16,446			
	e	- 26,211 - de					
	e=28,5	-30,211					
		h = 28		h = 30		h = 32	
		yP	zP	yP	zP	yP	zP
F1	e=32,5	-39,765	15,675	-40,530	17,779	-41,497	20,434
	e	- 39,765 - de		- 40,530 - de		- 41,497 - de	
	e=28,5	-43,765		-44,530		-45,497	
G1	e=32,5	-49,663	26,748	-47,758	27,568	-46,153	28,108
	e	- 49,663 - de		- 47,758 - de		- 46,153 - de	
	e=28,5	-53,663		-51,758		-50,153	
S	e=32,5	-55	28	-55	30	-55	32
	e=31,5	-55,5	27,990	-55,5	29,990	-55,5	31,990
	e=30,5	-56	27,958	-56	29,958	-56	31,958
	e=29,5	-56,5	27,906	-56,5	29,906	-56,5	31,906
	e=28,5	-57	27,832	-57	29,832	-57	31,832
H1		-62,765	25,149	-62,765	27,149	-62,765	29,149
H2		-70	9,519	-70	11,519	-70	13,519
Hm		-49,500		-49,500		-49,500	
Fm	e=32,5	-58,558	8,835	-60,733	10,425	-63,110	12,558
	e	- 58,558 - de		- 60,733 - de		- 63,110 - de	
	e=28,5	-62,558		-64,733		-67,110	
RIm		-55	16	-55	18	-55	20
REm	e=32,5	-55		-55		-55	
	e	- 55 - de		- 55 - de		- 55 - de	
	e=28,5	-59	-59	-59			
Rfa		20		21,5		23	
NOTE 1 yP: y co-ordinate of point P relative to D0 P: profile point zP: z co-ordinate of point P relative to D0.							
NOTE 2 de = 32,5 mm – e							
Example e = 30,5 mm de = (32,5 - 30,5) = 2 mm and yD1 = (- 35 - 2) = - 37 mm							

## Annex B (normative)

### 1/40th profile

#### B.1 Complete reference profile: construction with a 32,5 mm thick flange and 15 % reverse slope

The 1/40<sup>th</sup> profile is shown in Figure B.1

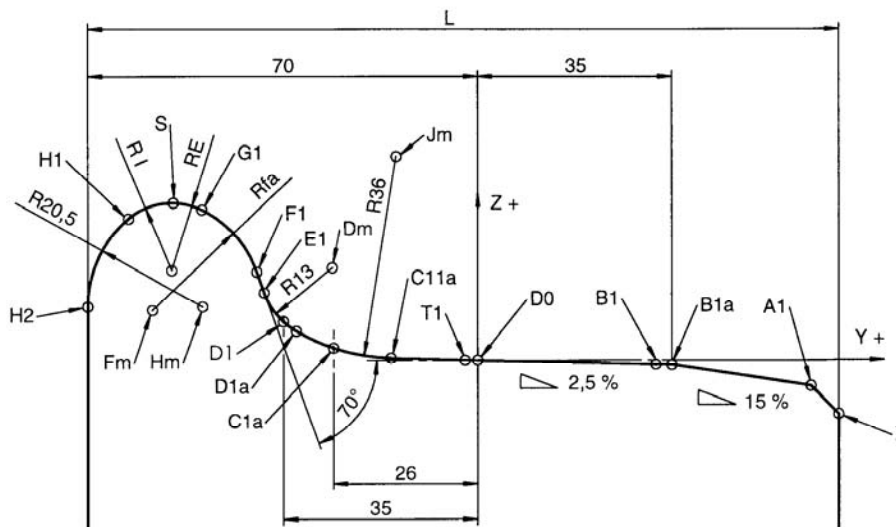

Figure B.1 – 1/40<sup>th</sup> profile

#### B.2 Profile construction: specific zones

- **D1 – D1a** arc of circle with 13 mm radius;
- **D1a – C11a** arc of circle with 36 mm radius;
- **C11a – B1a** straight line with 2,5 % slope;
- **B1a – A1** straight line with 15 % slope (permissible between 6,7 % and 15 %);
- **A1 – I** 5 mm x 5 mm chamfer.

Table B.1 — Co-ordinates of 1/40<sup>th</sup> profile points

1/40 : D1 → B1 a			
P	E	y <sub>P</sub>	z <sub>P</sub>
<b>Jm</b>	e=32,5	-14,740	36,380
	E	-14,740 – de	
	e=28,5	-18,740	
<b>D1</b>	e=32,5	-35	6,867
	E	-35 – de	
	e=28,5	-39	
<b>D1a</b>	e=32,5	-32,696	5,180
	E	- 32,696 – de	
	e=28,5	-36,696	
<b>C1a</b>	e=32,5	-26	2,187
	E	-26 – de	
	e=28,5	-30	
<b>C11a</b>	e=32,5	-15,640	0,391
	E	-15,640 – de	
	e=28,5	-19,640	
<b>T1</b>	e=32,5	-0,500	0,013
	E	-0,500 – de	
	e=28,5	-4,500	
<b>B1a</b>		35	-0,875

NOTE 1      **y<sub>P</sub>**: y co-ordinate of point P relative to D0      **P**: profile point      **z<sub>P</sub>**: z co-ordinate of point P relative to D0.

NOTE 2      de = 32,5 mm – e

Example e = 30,5 mm    de = (32,5 - 30,5) = 2 mm    and    y<sub>D1</sub> = (- 35 – 2) = - 37 mm

## Annex C (normative)

### S1002 profile

#### C.1 Complete reference profile: construction with 32,5 mm thick flange and 6,7 % reverse slope

The S 1002 profile is shown in Figure C.1.

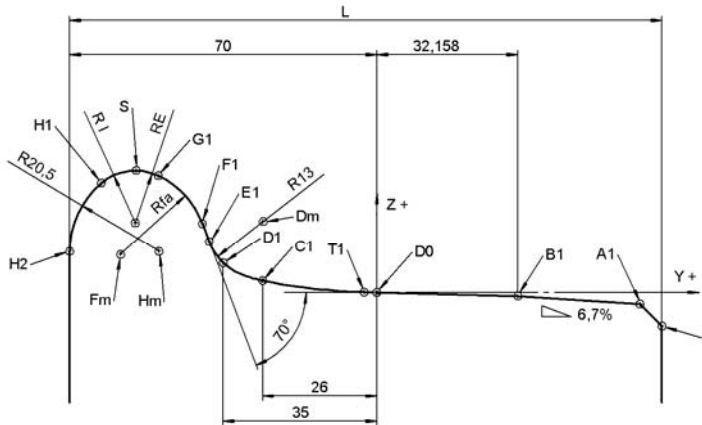

Figure C.1 — S 1002 profile

#### C.2 Profile construction: specific zones

- D1 – B1 co-ordinates given in Table C.1;
- B1 – A1 straight line with 6,7 % slope (permissible between 6,7 % and 15 %);
- A1 – I 5 mm x 5 mm chamfer.

Table C.1 — Co-ordinates of S 1002 profile points, zone D1 - D0 (B1)

S 1002 : D1 → D0 (B1) 1/4 (yP : - 39 → - 14 mm)										
yP	P	E								
		32,5	32	31,5	31	30,5	30	29,5	29	28,5
zP										
-39,0										6,867
-38,5										6,432
-38,0								6,867	6,432	6,038
-37,5							6,867	6,432	6,038	5,681
-37,0						6,867	6,432	6,038	5,681	5,357
-36,5					6,867	6,432	6,038	5,681	5,357	5,062
-36,0			6,867	6,432	6,038	5,681	5,357	5,062	4,793	4,547
-35,5		6,867	6,432	6,038	5,681	5,357	5,062	4,793	4,547	4,321
-35,0	<b>D1</b>	6,867	6,432	6,038	5,681	5,357	5,062	4,793	4,547	4,321
-34,5		6,432	6,038	5,681	5,357	5,062	4,793	4,547	4,321	4,114
-34		6,038	5,681	5,357	5,062	4,793	4,547	4,321	4,114	3,922
-33,5		5,681	5,357	5,062	4,793	4,547	4,321	4,114	3,922	3,743
-33,0		5,357	5,062	4,793	4,547	4,321	4,114	3,922	3,743	3,576
-32,5		5,062	4,793	4,547	4,321	4,114	3,922	3,743	3,576	3,419
-32,0		4,793	4,547	4,321	4,114	3,922	3,743	3,576	3,419	3,270
-31,5		4,547	4,321	4,114	3,922	3,743	3,576	3,419	3,270	3,129
-31,0		4,321	4,114	3,922	3,743	3,576	3,419	3,270	3,129	2,994
-30,5		4,114	3,922	3,743	3,576	3,419	3,270	3,129	2,994	2,865
-30,0		3,922	3,743	3,576	3,419	3,270	3,129	2,994	2,865	<b>2,741</b>
-29,5		3,743	3,576	3,419	3,270	3,129	2,994	2,865	<b>2,741</b>	2,623
-29,0		3,576	3,419	3,270	3,129	2,994	2,865	<b>2,741</b>	2,623	2,509
-28,5		3,419	3,270	3,129	2,994	2,865	<b>2,741</b>	2,623	2,509	2,401
-28,0		3,270	3,129	2,994	2,865	<b>2,741</b>	2,623	2,509	2,401	2,297
-27,5		3,129	2,994	2,865	<b>2,741</b>	2,623	2,509	2,401	2,297	2,197
-27,0		2,994	2,865	<b>2,741</b>	2,623	2,509	2,401	2,297	2,197	2,101
-26,5		2,865	<b>2,741</b>	2,623	2,509	2,401	2,297	2,197	2,101	2,008
-26,0	<b>C1</b>	<b>2,741</b>	2,623	2,509	2,401	2,297	2,197	2,101	2,008	1,920
-25,5		2,623	2,509	2,401	2,297	2,197	2,101	2,008	1,920	1,834
-25,0		2,509	2,401	2,297	2,197	2,101	2,008	1,920	1,834	1,752
-24,5		2,401	2,297	2,197	2,101	2,008	1,920	1,834	1,752	1,673
-24,0		2,297	2,197	2,101	2,008	1,920	1,834	1,752	1,673	1,597
-23,5		2,197	2,101	2,008	1,920	1,834	1,752	1,673	1,597	1,523
-23,0		2,101	2,008	1,920	1,834	1,752	1,673	1,597	1,523	1,452
-22,5		2,008	1,920	1,834	1,752	1,673	1,597	1,523	1,452	1,384
-22,0		1,920	1,834	1,752	1,673	1,597	1,523	1,452	1,384	1,318
-21,5		1,834	1,752	1,673	1,597	1,523	1,452	1,384	1,318	1,254
-21,0		1,752	1,673	1,597	1,523	1,452	1,384	1,318	1,254	1,193
-20,5		1,673	1,597	1,523	1,452	1,384	1,318	1,254	1,193	1,134
-20,0		1,597	1,523	1,452	1,384	1,318	1,254	1,193	1,134	1,076
-19,5		1,523	1,452	1,384	1,318	1,254	1,193	1,134	1,076	1,021
-19,0		1,452	1,384	1,318	1,254	1,193	1,134	1,076	1,021	0,967
-18,5		1,384	1,318	1,254	1,193	1,134	1,076	1,021	0,967	0,916
-18,0		1,318	1,254	1,193	1,134	1,076	1,021	0,967	0,916	0,866
-17,5		1,254	1,193	1,134	1,076	1,021	0,967	0,916	0,866	0,818
-17,0		1,193	1,134	1,076	1,021	0,967	0,916	0,866	0,818	0,771
-16,5		1,134	1,076	1,021	0,967	0,916	0,866	0,818	0,771	0,726
-16,0		1,076	1,021	0,967	0,916	0,866	0,818	0,771	0,726	0,682
-15,5		1,021	0,967	0,916	0,866	0,818	0,771	0,726	0,682	0,640
-15,0		0,967	0,916	0,866	0,818	0,771	0,726	0,682	0,640	0,600
-14,5		0,916	0,866	0,818	0,771	0,726	0,682	0,640	0,600	0,561
-14,0		0,866	0,818	0,771	0,726	0,682	0,640	0,600	0,561	0,523

NOTE yP: y co-ordinate of P relative to D0 P: profile point zP: z co-ordinate of point P relative to D0.

(continued)

Table C.1 (continued) — Co-ordinates of S 1002 profile points, zone D1 – D0 (B1)

S 1002 : D1 → D0 (B1) 2/4 (Yp : - 13,5 → 0,0 mm)										
Yp	P	E								
		32,5	32,0	31,5	31	30,5	30	29,5	29	28,5
Zp										
-13,5		0,818	0,771	0,726	0,682	0,640	0,600	0,561	0,523	0,486
-13,0		0,771	0,726	0,682	0,640	0,600	0,561	0,523	0,486	0,451
-12,5		0,726	0,682	0,640	0,600	0,561	0,523	0,486	0,451	0,417
-12,0		0,682	0,640	0,600	0,561	0,523	0,486	0,451	0,417	0,384
-11,5		0,640	0,600	0,561	0,523	0,486	0,451	0,417	0,384	0,352
-11,0		0,600	0,561	0,523	0,486	0,451	0,417	0,384	0,352	0,322
-10,5		0,561	0,523	0,486	0,451	0,417	0,384	0,352	0,322	0,292
-10,0		0,523	0,486	0,451	0,417	0,384	0,352	0,322	0,292	0,264
-9,5		0,486	0,451	0,417	0,384	0,352	0,322	0,292	0,264	0,237
-9,0		0,451	0,417	0,384	0,352	0,322	0,292	0,264	0,237	0,211
-8,5		0,417	0,384	0,352	0,322	0,292	0,264	0,237	0,211	0,185
-8,0		0,384	0,352	0,322	0,292	0,264	0,237	0,211	0,185	0,161
-7,5		0,352	0,322	0,292	0,264	0,237	0,211	0,185	0,161	0,138
-7,0		0,322	0,292	0,264	0,237	0,211	0,185	0,161	0,138	0,116
-6,5		0,292	0,264	0,237	0,211	0,185	0,161	0,138	0,116	0,094
-6,0		0,264	0,237	0,211	0,185	0,161	0,138	0,116	0,094	0,074
-5,5		0,237	0,211	0,185	0,161	0,138	0,116	0,094	0,074	0,054
-5,0		0,211	0,185	0,161	0,138	0,116	0,094	0,074	0,054	0,035
-4,5		0,185	0,161	0,138	0,116	0,094	0,074	0,054	0,035	0,017
-4,0		0,161	0,138	0,116	0,094	0,074	0,054	0,035	0,017	0,015
-3,5		0,138	0,116	0,094	0,074	0,054	0,035	0,017	0,014	0,013
-3,0		0,166	0,094	0,074	0,054	0,035	0,017	0,014	0,012	0,011
-2,5		0,094	0,074	0,054	0,035	0,017	0,014	0,011	0,010	0,009
-2,0		0,074	0,054	0,035	0,017	0,013	0,011	0,008	0,008	0,007
-1,5		0,054	0,035	0,017	0,012	0,009	0,008	0,006	0,006	0,005
-1,0		0,035	0,017	0,011	0,008	0,006	0,005	0,004	0,004	0,003
-0,5	<b>T1</b>	0,017	0,008	0,005	0,004	0,003	0,002	0,002	0,002	0,001
0,0	<b>D0</b>	0,000								

Deleted: ,  
 Deleted: ,  
 Deleted: ,  
 Deleted: ,  
 Deleted: ,  
 Deleted: ,  
 Deleted: ,

NOTE yP: y co-ordinate of P relative to D0 P: profile point zP: z co-ordinate of point P relative to D0.

(continued)

Table C.1 (concluded) — Co-ordinates of S 1002 profile points,  
zone (D1) D0 - B1 (yP : 0,0 → 32,158 mm)

S 1002 : D0 → B1 $\frac{3}{4}$ ( yP : 0,0 → 16 )			S 1002 : D0 → B1 $\frac{4}{4}$ ( yP : 16,5 → 32,158 )		
		e : 32,5 → 28,5			e : 32,5 → 28,5
yP	P	zP	yP	P	zP
0,0	<b>D0</b>	0,000	16,5		-0,269
0,5		-0,016	17,0		-0,274
1,0		-0,032	17,5		-0,280
1,5		-0,047	18,0		-0,285
2,0		-0,061	18,5		-0,291
2,5		-0,075	19,0		-0,298
3,0		-0,087	19,5		-0,304
3,5		-0,100	20,0		-0,312
4,0		-0,111	20,5		-0,320
4,5		-0,122	21,0		-0,328
5,0		-0,132	21,5		-0,338
5,5		-0,142	22,0		-0,348
6,0		-0,151	22,5		-0,358
6,5		-0,160	23,0		-0,370
7,0		-0,168	23,5		-0,382
7,5		-0,176	24,0		-0,396
8,0		-0,183	24,5		-0,410
8,5		-0,190	25,0		-0,426
9,0		-0,196	25,5		-0,443
9,5		-0,203	26,0		-0,460
10,0		-0,208	26,5		-0,479
10,5		-0,214	27,0		-0,499
11,0		-0,219	27,5		-0,521
11,5		-0,224	28,0		-0,543
12,0		-0,229	28,5		-0,567
12,5		-0,234	29,0		-0,592
13,0		-0,238	29,5		-0,619
13,5		-0,242	30,0		-0,646
14,0		-0,247	30,5		-0,675
14,5		-0,251	31,0		-0,705
15,0		-0,256	31,5		-0,737
15,5		-0,260	32,0		-0,769
16,0		-0,265	32,158	<b>B1</b>	-0,780

NOTE yP: y co-ordinate of P relative to D0 P: profile point zP: z co-ordinate of point P relative to D0.

## Annex D (normative)

### EPS profile

#### D.1 Complete reference profile: construction with 32,5 mm thick flange and 10 % reverse slope

Figure D.1 shows the EPS profile for a 32,5 mm thick flange.

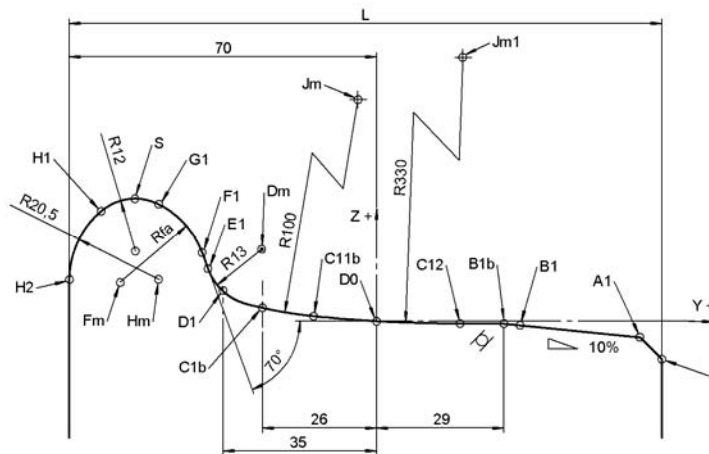

Figure D.1 — EPS profile

#### D.2 Profile construction: specific zones

- **D1 – C1b** co-ordinates given in Table D.1;
- **C1b – C11b** arc of circle with 100 mm radius;
- **C11b – B1b** arc of circle with 330 mm radius;
- **C12 – B1b** straight line parallel to the Y axis;
- **B1b – A1** straight line with slope of 10 % (permissible between 6,7 % and 15 %);
- **A1 - I** 5 mm x 5 mm chamfer.



Table D.1 — Co-ordinates of EPS profile points, zone B1b - D1

EPS : D1 → C1b										
		e								
		32,5	32	31,5	31	30,5	30 <sup>a</sup>	29,5	29	28,5
yP	P	zP								
-39,0										6,867
-38,5									6,867	6,464
-38,0								6,867	6,468	6,104
-37,5							6,867	6,469	6,108	5,780
-37,0						6,867	6,476	6,110	5,784	5,488
-36,5					6,867	6,468	6,122	5,785	5,491	5,224
-36,0				6,867	6,467	6,107	5,802	5,490	5,226	4,985
-35,5			6,867	6,466	6,105	5,780	5,513	5,225	4,986	4,768
-35,0	<b>D1</b>	6,867	6,466	6,104	5,778	5,486	5,251	4,985	4,769	4,573
-34,5		6,466	6,104	5,778	5,484	5,220	5,016	4,769	4,575	4,398
-34,0		6,108	5,781	5,486	5,221	4,983	4,806	4,576	4,400	4,241
-33,5		5,788	5,493	5,227	4,987	4,772	4,619	4,404	4,245	4,101
-33,0		5,507	5,239	4,998	4,781	4,586	4,454	4,252	4,109	3,978
-32,5		5,262	5,018	4,799	4,602	4,424	4,310	4,121	3,990	3,871
-32,0		5,044	4,822	4,622	4,442	4,280	4,176	4,003	3,884	3,776
-31,5		4,832	4,631	4,449	4,286	4,140	4,046	3,889	3,781	3,683
-31,0		4,624	4,444	4,281	4,134	4,003	3,918	3,777	3,680	3,592
-30,5		4,421	4,260	4,116	3,985	3,868	3,793	3,668	3,582	3,503
-30,0		4,222	4,081	3,954	3,840	3,737	3,671	3,561	3,485	3,417
-29,5		4,028	3,906	3,796	3,697	3,609	3,552	3,456	3,391	3,332
-29,0		3,838	3,735	3,642	3,558	3,483	3,435	3,354	3,299	3,248
-28,5		3,652	3,567	3,491	3,422	3,360	3,321	3,254	3,209	3,167
-28,0		3,471	3,404	3,344	3,289	3,240	3,209	3,157	3,121	3,088
-27,5		3,295	3,245	3,200	3,160	3,124	3,100	3,062	3,035	3,011
-27,0		3,122	3,089	3,060	3,033	3,010	2,994	2,969	2,951	2,935
-26,5		2,954	2,938	2,923	2,910	2,898	2,891	2,878	2,870	2,862
-26,0	<b>C1b</b>	2,790	2,790	2,790	2,790	2,790	2,790	2,790	2,790	2,790

NOTE yP: y co-ordinate of point P relative to D0 P: profile point zP: z co-ordinate of point P relative to D0.

<sup>a</sup> Profile equivalent to profile P8 in the zone D1 – C1b.

Table D.2 – Co-ordinates of the EPS profile points, zone C1b – B1b

EPS : C1b → B1b		
P	yP	zP
<b>Jm</b>	-6,5	100,871
<b>Jm1</b>	19	329,453
<b>C1b</b>	-26	2,79
<b>C11b</b>	-17,587	1,487
<b>C12</b>	19	-0,547
<b>B1b</b>	29	-0,547

NOTE 1 **yP**: y co-ordinate of point P relative to D0 **P**: profile point **zP**: z co-ordinate of point P relative to D0.

NOTE 2 Profile equivalent to profile P8 in the zones between points C1b and B1b.

## Annex ZA (informative)

### Relationship between this European Standard and the Essential Requirements of EU Directive 96/48/EC

This European Standard has been prepared **under a mandate given to CEN** by the European Commission and the European Free Trade Association to provide a means of conforming to Essential Requirements of the New Approach EU Directive 96/48/EC of 23 July 1996 on the interoperability of the trans-European high-speed rail system.

Once this standard is cited in the Official Journal of the European Communities under that Directive and has been implemented as a national standard in at least one Member State, compliance with the clauses of this standard given in table ZA confers, within the limits of the scope of this standard, a presumption of conformity with the corresponding Essential Requirements of that Directive and associated EFTA regulations.

**Table ZA – Correspondence between this European Standard and Directive 96/48/EC**

Clause(s)/sub-clause(s)/annex(es) of this European Standard	Clause(s)/sub-clause(s)/annex(es) of the revised TSI on the "rolling stock" sub-system of the trans-European high speed railway system	Text corresponding to the clause(s)/sub-clause(s)/annex(es) of Directive 96/48/EC	Comments
<p><a href="#">Clause 3 - Definition of tread profile</a> <a href="#">Annex A - Flange</a></p> <p><a href="#">Clause 4 - Symbols and abbreviations</a> <a href="#">§ 4.1 Definition of the profiles</a></p> <p><a href="#">Clause 6 - Geometric characteristics</a> <a href="#">§ 6.1 to 6.6</a></p> <p><a href="#">Annex B - 1/40<sup>th</sup> profile</a> <a href="#">Annex C - S 1002 profile</a> <a href="#">Annex D - EPS profile</a></p> <p><a href="#">Clause 8 - Reference equipment for verification of the wheel profile</a></p>	<p><a href="#">§ 4.2.3.4</a> Dynamic behaviour of the rolling stock – <a href="#">4.2.3.4.1 – 4.2.3.4.4 – 4.2.3.4.7 - 4.2.3.4.8</a></p> <p><a href="#">§ 4.3.2.6</a> Dynamic behaviour of the rolling stock and wheel profiles</p> <p><a href="#">5.3 List</a> of components</p> <p><a href="#">5.4 Performance</a> of components and specifications</p> <p><a href="#">Annex M</a> – Limit values on the use of the geometric characteristics of wheels and wheelsets</p>	<p><a href="#">Chapter II Article 5 points 3.(a); 3.(d)</a></p> <p><a href="#">Annex III Articles 1.1.2; 2.4.2; 2.4.3</a></p> <p><a href="#">Chapter II Article 5 point 3e</a></p> <p><a href="#">Chapter III Article 8</a></p>	<p>The revised high-speed TSI on the "rolling stock" sub-system cites EN 13715 in its <a href="#">4.2.3.4.7</a> and the two reference profiles: <a href="#">1/40<sup>th</sup></a> and <a href="#">S 1002</a>.</p>

**WARNING** – Other requirements and other EU Directives may be applicable to the product(s) falling within the scope of this standard.

## Annex ZB (informative)

### Relationship between this European Standard and the Essential Requirements of EU Directive 2001/16/EC

This European Standard has been prepared **under a mandate given to CEN** by the European Commission and the European Free Trade Association to provide a means of conforming to Essential Requirements of the New Approach EU Directive 2001/16/EC of 19 March 2001 on the interoperability of the conventional trans-European rail system.

Once this standard is cited in the Official Journal of the European Communities under that Directive and has been implemented as a national standard in at least one Member State, compliance with the clauses of this standard given in table ZB confers, within the limits of the scope of this standard, a presumption of conformity with the corresponding Essential Requirements of that Directive and associated EFTA regulations.

**Table ZB — Correspondence between this European Standard and Directive 2001/16/EC**

<b>Clause(s)/sub-clause(s) of this EN</b>	<b>Clauses/§/points and annexes of the Rolling Stock TSI of January 2005 and approved by the committee charged with the interoperability and safety of the European rail system</b>	<b>Essential Requirements of Directive 2001/16/EC</b>	<b>Comments/Notes</b>
<p><b>Clause 3 - Definition</b> of tread profile</p> <p><b>Annex A - Flange</b></p> <p><b>Clause 4 - Symbols</b> and abbreviations</p> <p><b>§ 4.1 Definition</b> of the profiles</p> <p><b>Clause 6 – Geometric characteristics</b></p> <p><b>§ 6.1 to 6.6</b></p> <p><b>Clause 8 – Reference equipment</b> for verification of the wheel profile</p>	<p>Clause <b>4 - Characteristics</b> of the sub-system</p> <p><b>§4.2.3.4.1</b> Functional and technical specifications of the sub-system, vehicle-track interaction and general gauge</p> <p>Clause <b>5 – Interoperability components</b></p> <p><b>§ 5.3.2 List</b> of components, vehicle-track interaction</p> <p><b>§ 5.4.2 Performance</b> of components and specifications, vehicle-track interaction</p> <p>Clause <b>6 – Assessment</b> of conformity and/or suitability for use of components and verification of the sub-system</p> <p><b>§ 6.1.3.2: Specification</b> for evaluation of the IC, vehicle-</p>	<p><b>Annex III, Essential requirements, General requirements – 1.1.1, 1.1.2, 1.1.3 Safety</b></p> <p><b>Annex III, Essential requirements, General Requirements – 1.2 Reliability and availability</b></p> <p><b>Annex III, Essential requirements, General Requirements – 1.4.4, 1.4.5 Environmental Protection</b></p> <p><b>Annex III, Essential requirements, General Requirements – 1.5 Technical compatibility</b></p> <p><b>Annex III, Essential requirements, Requirements specific to</b></p>	<p>The reference profiles given in <b>Annexes B, C and D</b> are <b>normative</b> only if the are selected by the tread profile designer.</p> <p>The conventional rail rolling stock STI does not make it mandatory for the vehicle operator to use a specific profile or an effective concity in order to ensure that the profile selected meets the STI requirements for safety in use. Also, <b>EN 13715</b> does not restrict the selection of the <b>profile</b> in the reference annexes; the flange and the geometry of the running angle are simply normative</p>

	<p>track inter<u>action</u> and gauge</p> <p><u>Annex E</u>: Vehicle-track inter<u>action</u> and gauge, <u>dimensions</u> of axles and <u>tolerances</u> for the standardized gauge</p> <p><u>Annex K</u>: Vehicle-track inter<u>action</u> and gauge, <u>wheelsets</u></p> <p><u>Annex L</u>: Vehicle-track inter<u>action</u> and gauge, <u>wheels</u></p> <p><u>Annex M</u>: Vehicle-track inter<u>action</u> and gauge, <u>axle</u></p> <p><u>Annex Q</u>: <u>Evaluation</u> of procedures, <u>interoperability</u> of the components</p> <p><u>Annex Y</u>: <u>Components</u>, <u>bogies</u> and running gear</p>	<p>each sub-system, control and command and signalling – <u>2.3.2</u></p> <p><u>Annex III</u>, Essential Requirements, Requirements specific to each sub-system, rolling stock – <u>2.4.1</u> Safety</p> <p><u>Annex III</u>, Essential Requirements, Requirements specific to each sub-system, rolling stock – <u>2.4.2</u> Reliability and availability</p>	
--	---	---	--

**WARNING** – Other requirements and other EU Directives may be applicable to the product(s) falling within the scope of this standard.

## Bibliography

- [1] UIC 510-2 *Trailing stock – Wheels and wheelsets - Conditions concerning the use of wheels of various diameters*

---

---

# BSI — British Standards Institution

BSI is the independent national body responsible for preparing British Standards. It presents the UK view on standards in Europe and at the international level. It is incorporated by Royal Charter.

## Revisions

British Standards are updated by amendment or revision. Users of British Standards should make sure that they possess the latest amendments or editions.

It is the constant aim of BSI to improve the quality of our products and services. We would be grateful if anyone finding an inaccuracy or ambiguity while using this British Standard would inform the Secretary of the technical committee responsible, the identity of which can be found on the inside front cover.  
Tel: +44 (0)20 8996 9000. Fax: +44 (0)20 8996 7400.

BSI offers members an individual updating service called PLUS which ensures that subscribers automatically receive the latest editions of standards.

## Buying standards

Orders for all BSI, international and foreign standards publications should be addressed to Customer Services. Tel: +44 (0)20 8996 9001.  
Fax: +44 (0)20 8996 7001. Email: [orders@bsi-global.com](mailto:orders@bsi-global.com). Standards are also available from the BSI website at <http://www.bsi-global.com>.

In response to orders for international standards, it is BSI policy to supply the BSI implementation of those that have been published as British Standards, unless otherwise requested.

## Information on standards

BSI provides a wide range of information on national, European and international standards through its Library and its Technical Help to Exporters Service. Various BSI electronic information services are also available which give details on all its products and services. Contact the Information Centre.  
Tel: +44 (0)20 8996 7111. Fax: +44 (0)20 8996 7048. Email: [info@bsi-global.com](mailto:info@bsi-global.com).

Subscribing members of BSI are kept up to date with standards developments and receive substantial discounts on the purchase price of standards. For details of these and other benefits contact Membership Administration.  
Tel: +44 (0)20 8996 7002. Fax: +44 (0)20 8996 7001.  
Email: [membership@bsi-global.com](mailto:membership@bsi-global.com).

Information regarding online access to British Standards via British Standards Online can be found at <http://www.bsi-global.com/bsonline>.

Further information about BSI is available on the BSI website at <http://www.bsi-global.com>.

## Copyright

Copyright subsists in all BSI publications. BSI also holds the copyright, in the UK, of the publications of the international standardization bodies. Except as permitted under the Copyright, Designs and Patents Act 1988 no extract may be reproduced, stored in a retrieval system or transmitted in any form or by any means – electronic, photocopying, recording or otherwise – without prior written permission from BSI.

This does not preclude the free use, in the course of implementing the standard, of necessary details such as symbols, and size, type or grade designations. If these details are to be used for any other purpose than implementation then the prior written permission of BSI must be obtained.

Details and advice can be obtained from the Copyright & Licensing Manager.  
Tel: +44 (0)20 8996 7070. Fax: +44 (0)20 8996 7553.  
Email: [copyright@bsi-global.com](mailto:copyright@bsi-global.com).