

Execution of concrete structures

ICS 91.080.40

National foreword

This British Standard is the UK implementation of EN 13670:2009. It supersedes DD ENV 13670-1:2000 which is withdrawn.

The UK participation in its preparation was entrusted to Technical Committee B/525/2, Structural use of concrete.

A list of organizations represented on this committee can be obtained on request to its secretary.

The Execution Specification requirements provided by the UK committee are given in the National Annex NA (informative).

This publication does not purport to include all the necessary provisions of a contract. Users are responsible for its correct application.

Compliance with a British Standard cannot confer immunity from legal obligations.

This British Standard was published under the authority of the Standards Policy and Strategy Committee on 28 February 2010

© BSI 2010

ISBN 978 0 580 67067 1

Amendments/corrigenda issued since publication

Date	Comments

EUROPEAN STANDARD

EN 13670

NORME EUROPÉENNE

EUROPÄISCHE NORM

December 2009

ICS 91.080.40

Supersedes ENV 13670-1:2000

English Version

Execution of concrete structures

Exécution des structures en béton

Ausführung von Tragwerken aus Beton

This European Standard was approved by CEN on 17 September 2009.

CEN members are bound to comply with the CEN/CENELEC Internal Regulations which stipulate the conditions for giving this European Standard the status of a national standard without any alteration. Up-to-date lists and bibliographical references concerning such national standards may be obtained on application to the CEN Management Centre or to any CEN member.

This European Standard exists in three official versions (English, French, German). A version in any other language made by translation under the responsibility of a CEN member into its own language and notified to the CEN Management Centre has the same status as the official versions.

CEN members are the national standards bodies of Austria, Belgium, Bulgaria, Cyprus, Czech Republic, Denmark, Estonia, Finland, France, Germany, Greece, Hungary, Iceland, Ireland, Italy, Latvia, Lithuania, Luxembourg, Malta, Netherlands, Norway, Poland, Portugal, Romania, Slovakia, Slovenia, Spain, Sweden, Switzerland and United Kingdom.



EUROPEAN COMMITTEE FOR STANDARDIZATION
COMITÉ EUROPÉEN DE NORMALISATION
EUROPÄISCHES KOMITEE FÜR NORMUNG

Management Centre: Avenue Marnix 17, B-1000 Brussels

Contents

Page

Foreword.....	5
Introduction	6
1 Scope	7
2 Normative references	7
3 Definitions	8
4 Execution management	11
4.1 Assumptions	11
4.2 Documentation.....	11
4.2.1 Execution specification.....	11
4.2.2 Quality Plan	12
4.2.3 Execution record documentation.....	12
4.2.4 Special record documentation	12
4.3 Quality Management.....	12
4.3.1 Execution classes	12
4.3.2 Inspection of materials and products.....	13
4.3.3 Inspection of execution.....	13
4.4 Action in the event of a non-conformity.....	14
5 Falsework and formwork	15
5.1 Basic requirements.....	15
5.2 Materials	15
5.2.1 General.....	15
5.2.2 Release agents.....	15
5.3 Design and installation of falsework	15
5.4 Design and installation of formwork.....	16
5.5 Special formwork.....	16
5.6 Inserts in formwork and embedded components	16
5.6.1 General.....	16
5.6.2 Making good of temporary recesses and holes	17
5.7 Removal of formwork and falsework	17
6 Reinforcement.....	17
6.1 General.....	17
6.2 Materials	17
6.3 Bending, cutting, transport and storage of the reinforcement	18
6.4 Welding.....	19
6.5 Joints	19
7 Prestressing	19
7.1 General.....	19
7.2 Materials for prestressing	20
7.2.1 Post-tensioning systems	20
7.2.2 Sheaths	20
7.2.3 Tensile elements	20
7.2.4 Anchorage elements and accessories	20
7.2.5 Tendon supports.....	20
7.2.6 Cement-based grout.....	21
7.2.7 Grease, wax or other products.....	21
7.3 Transport and storage.....	21
7.4 Installation of tendons	21
7.4.1 General.....	21

7.4.2	Pre-tensioned tendons.....	21
7.4.3	Post-tensioned bonded tendons	22
7.4.4	Internal and external unbonded tendons.....	22
7.5	Tensioning	22
7.5.1	General	22
7.5.2	Pre-tensioned tendons.....	22
7.5.3	Post-tensioned bonded tendons	23
7.5.4	Internal and external unbonded tendons.....	23
7.6	Protective measures (grouting, greasing)	23
7.6.1	General	23
7.6.2	Pre-tensioned tendons.....	23
7.6.3	Post-tensioned bonded tendons	23
7.6.4	Internal or external unbonded tendons.....	23
7.6.5	Grouting operations	23
7.6.6	Greasing operations.....	24
7.6.7	Sealing	24
8	Concreting.....	24
8.1	Specification of concrete.....	24
8.2	Pre-concreting operations.....	24
8.3	Delivery, reception and site transport of fresh concrete	25
8.4	Placing and compaction	25
8.4.1	General	25
8.4.2	Lightweight Aggregate Concrete	26
8.4.3	Self Compacting Concrete.....	26
8.4.4	Sprayed concrete	26
8.4.5	Slipforming.....	26
8.4.6	Underwater concreting	26
8.5	Curing and protection.....	26
8.6	Post-concreting operations.....	28
8.7	Concreting of composite structures	28
8.8	Surface Finish.....	28
9	Execution with precast concrete elements.....	28
9.1	General	28
9.2	Factory produced precast elements.....	28
9.3	Site manufactured precast elements.....	29
9.4	Handling and storage.....	29
9.4.1	General	29
9.4.2	Handling	29
9.4.3	Storage	29
9.5	Placing and adjustment	29
9.5.1	General	29
9.5.2	Placing.....	29
9.6	Jointing and completion works	30
9.6.1	General	30
9.6.2	In-situ works	30
9.6.3	Structural connections	30
10	Geometrical tolerances.....	31
10.1	General	31
10.2	Reference system.....	32
10.3	Base supports (foundations).....	32
10.4	Columns and walls	32
10.5	Beams and slabs	34
10.6	Sections.....	35
10.7	Surfaces and edge straightness	37
10.8	Tolerances for holes and inserts	37
Annex A	(informative) Guidance on documentation	38
Annex B	(informative) Guidance on Quality Management.....	43

Annex C (informative) Guidance on falsework and formwork	45
Annex D (informative) Guidance on reinforcement	47
Annex E (informative) Guidance on prestressing	49
Annex F (informative) Guidance on concreting	52
Annex G (informative) Guidance on geometrical tolerances	58
Annex H (informative) Guidance on National Annex	65
Bibliography	66

Foreword

This document (EN 13670:2009) has been prepared by Technical Committee CEN/TC 104 "Concrete and related products", the secretariat of which is held by DIN.

This European Standard shall be given the status of a national standard, either by publication of an identical text or by endorsement, at the latest by June 2010, and conflicting national standards shall be withdrawn at the latest by June 2010.

Attention is drawn to the possibility that some of the elements of this document may be the subject of patent rights. CEN [and/or CENELEC] shall not be held responsible for identifying any or all such patent rights.

This document supersedes ENV 13670-1:2000.

This document has been prepared under a mandate given to CEN by the European Commission and the European Free Trade Association, and supports essential requirements of EC Directive(s).

Because of the close connection between design rules and rules for execution, CEN/TC 104/SC 2 has developed this standard in liaison with CEN/TC 250/SC 2, and CEN TC 229

According to the CEN/CENELEC Internal Regulations, the national standards organizations of the following countries are bound to implement this European Standard: Austria, Belgium, Bulgaria, Cyprus, Czech Republic, Denmark, Estonia, Finland, France, Germany, Greece, Hungary, Iceland, Ireland, Italy, Latvia, Lithuania, Luxembourg, Malta, Netherlands, Norway, Poland, Portugal, Romania, Slovakia, Slovenia, Spain, Sweden, Switzerland and the United Kingdom.

Introduction

This European Standard applies to the execution of concrete structures to achieve the intended level of safety and serviceability during its service life, as given by EN 1990, *Eurocode – Basis of structural design*, EN 1992, *Eurocode 2 – Design of concrete structures* and EN 1994, *Eurocode 4 – Design of composite steel and concrete structures*, with the Nationally Determined Parameters (NDPs) applicable in the place of use.

This European Standard has three functions:

- a) to transfer the requirements set during design to the constructor i.e. to be a link between design and execution;
- b) to give a set of standardized technical requirements for the execution when ordering a concrete structure;
- c) to serve as a check list for the designer to ensure that he provides the constructor with all relevant technical information for the execution of the structure (see Annex A).

In order to achieve these objectives, the design shall result in a set of documents and drawings giving all information required for the execution of the work in accordance with the plans. This set of documents is, in this European Standard, referred to as the "execution specification". This standard leaves a number of items open to be decided in the execution specification.

In areas where national provisions shall apply these should be referred to in the execution specification.

It is recognised in this European Standard that areas such as detailed requirements for competence of personnel, and details related to the Quality Management are within the competence of the Member States.

If the national CEN member publishes a National Annex to this standard, it may refer to national standards approved and published by the CEN member or national provisions, which supplement this standard, alternatively the supplementing rules can be given directly in the National Annex

A detailed overview of the system of European Standards related to concrete works is shown in Figure 1.

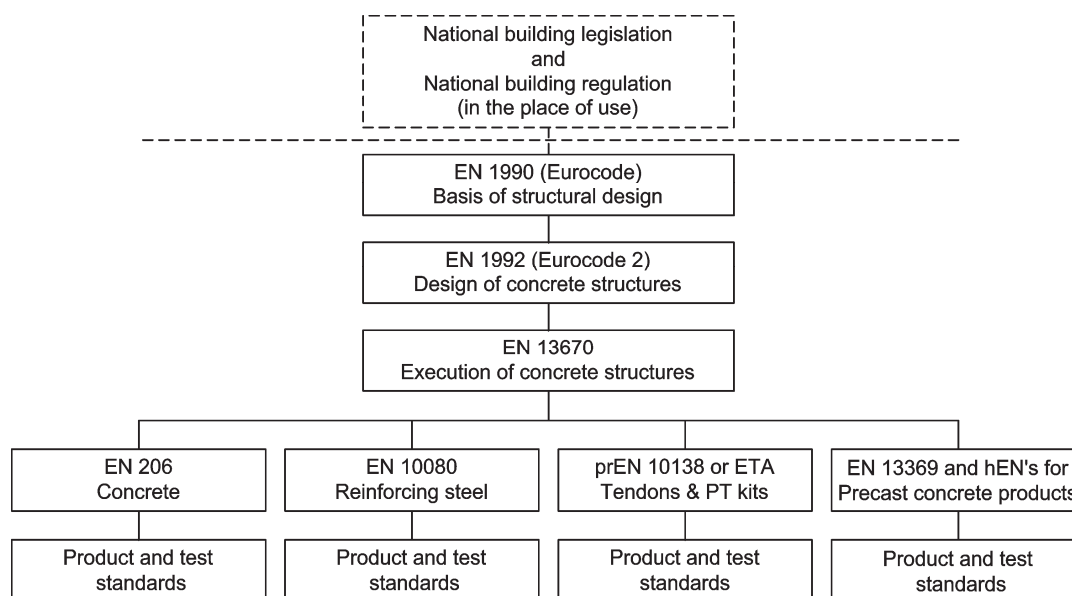

Figure 1 — System of European Standards as basis for design, execution and materials selection for concrete works (only main modules)

1 Scope

- (1) This European Standard gives common requirements for execution of concrete structures, it applies to both in-situ works and construction using prefabricated concrete elements.
- (2) This standard expects the execution specification to state all the specific requirements relevant to the particular structure.
- (3) This standard is applicable to permanent as well as temporary concrete structures.
- (4) Additional or different requirements should be considered and, if required, given in the execution specification when using:
 - a) lightweight aggregate concrete;
 - b) other materials (e.g. fibres) or constituent materials;
 - c) special technologies/innovative designs.
- (5) This standard does not apply to concrete members used only as equipment or construction aids for the execution.
- (6) This standard does not cover the specification, production and conformity of concrete.
- (7) This standard is not applicable to the production of precast concrete elements made in accordance with product standards.
- (8) This standard does not cover safety and health aspects of execution, or third party safety requirements.
- (9) This standard does not cover contractual issues or responsibilities for the identified actions.

NOTE It is within the concept of this standard that supplementing requirements can be given for the individual project in the execution specification, on a national level in a national annex, or on a general basis in European standards for special applications e.g. standards for special geotechnical works.

2 Normative references

The following referenced documents are indispensable for the application of this document. For dated references, only the edition cited applies. For undated references, the latest edition of the referenced document (including any amendments) applies.

EN 206-1, *Concrete — Part 1: Specification, performance, production and conformity*

EN 446, *Grout for prestressing tendons — Grouting procedures*

EN 447, *Grout for prestressing tendons — Basic requirements*

EN 523, *Steel strip sheaths for prestressing tendons — Terminology, requirements, quality control*

EN 10080, *Steel for the reinforcement of concrete — Weldable reinforcing steel — General*

EN ISO 17660-1, *Welding — Welding of reinforcing steel — Part 1: Load-bearing welded joints (ISO 17660-1:2006)*

EN ISO 17660-2, *Welding — Welding of reinforcing steel — Part 2: Non load-bearing welded joints (ISO 17660-2:2006)*

ETAG 013, *Guideline for European Technical Approval of Post-tensioning kits for prestressing of structures*
These are commonly called post-tensioning systems¹⁾

3 Terms and definitions

For the purposes of this document, the following terms and definitions apply.

3.1 backpropping

propping installed at levels below the slab that supports the falsework in order to distribute the load to suitable support

3.2 chair for reinforcement

device used to secure the position between reinforcement layers e.g. supporting top reinforcement in a slab

3.3 construction works

everything that is constructed or results from construction operations

[EN 1990]

NOTE The term covers both building and civil engineering works. It refers to the complete construction works comprising structural and non-structural and geotechnical elements.

3.4 constructor

organization executing the works

3.5 erection specification

documents covering all drawings, technical data and requirements required for the safe erection of precast elements

3.6 execution

all activities carried out for the physical completion of the work, i.e. procurement, scaffolding, formwork, reinforcing, concreting, curing, erection of precast elements etc., and the inspection and documentation thereof

3.7 execution class

classified set of requirements specified for the execution of the works as a whole or an individual component

3.8 execution specification

documents covering all drawings, technical data and requirements necessary for the execution of a particular project

NOTE The execution specification is not one document but signifies the total sum of documents required for the execution of the work as provided by the designer to the constructor. It includes the project specification prepared to supplement and qualify the requirements of this European Standard, as well as referring to the national provisions relevant in the place of use.

1) Available free online at www.eota.be

3.9

falsework

temporary support for a part of a structure while it is not self-supporting and for associated service load

3.10

formwork

structure, permanent or temporary, for containing poured concrete, moulding it to the required dimensions and supporting it until it is able to support itself

NOTE Formwork consists of the face contact material and the bearers directly supporting the face contact material.

3.11

inspection

conformity evaluation by observation and judgement accompanied as appropriate by measurement, testing or gauging

[EN ISO 9000]

3.12

method statement

documentation describing the methods and procedures to be used to perform the work

3.13

permitted deviation

permitted algebraic differences between the limits of size and the corresponding reference size

[Adapted from ISO 1803:1997, 3.8]

3.14

precast concrete element

concrete element cast and cured in a place other than the final location of use (factory produced or site manufactured)

NOTE 1 Precast concrete element manufactured in compliance with relevant European product standard is called precast concrete product.

NOTE 2 In this standard the shorter terms "precast element" and "precast product" are used.

3.15

project specification

project specific document describing the requirements applicable for the particular project

3.16

quality plan

document specifying which procedures and associated resources shall be applied by whom and when to a specific project, product, process or contract

[EN ISO 9000:2005, 3.7.5]

NOTE Guidance might be found in EN ISO 9000 concerning the content of a quality plan.

3.17

reference line

line defined in the execution specification to which positions are related

3.18
secondary line

any line used for the purpose of setting-out the proposed building and for checking and compliance of the building or building parts

[ISO 4463-1:1989, 4.4]

3.19
spacer

device used to secure correct spacing between the formwork and the reinforcement

3.20
surface finish

description of the appearance of the concrete surface including aspects of geometry, texture, colour etc.

3.21
temporary structure

structure designed for a short design working life

3.22
tolerance

difference between upper limit of size and the lower limit of size

[ISO 1803:1997, 3.11]

NOTE 1 Geometrical tolerances for precast concrete elements are subdivided as follows:

- a) production tolerances as defined in the product standards;
- b) erection tolerances i.e. geometrical tolerances relating to location, verticality, horizontality or other characteristics of the construction assembly;
- c) construction tolerances i.e. geometrical tolerances that are a combination of production, site construction and erection tolerances.

NOTE 2 Tolerance is an absolute value without sign, it is however commonly expressed by "the sum of the \pm permitted deviation" so that the value of the tolerance is implicit.

3.23
normal tolerances

basic limits for geometrical deviations that ensures that the structure:

- a) satisfies the design assumptions;
- b) achieves other functional requirements of the construction works.

NOTE In this standard, normal tolerances are referred to as tolerance class 1.

3.24
special tolerances

other tolerances than normal tolerances

3.25
works

parts of the construction works that are structural concrete work and are described in the execution specification

4 Execution management

4.1 Assumptions

(1) This European standard assumes:

- a) the availability of a comprehensive design of the structure;
- b) a project management in charge of the supervision of the works which will enable the execution of a conforming structure;
- c) a site management which will take charge of the organisation of the works and enable the correct and safe use of the equipment and machinery, the required quality of materials, the execution of a conforming structure and its safe use up to the delivery of the works.

(2) When precast elements are used, the following additional assumptions are made:

- a) the availability of a specific design of the precast elements conforming to the relevant standards;
- b) the availability of a design coordination between precast elements and site manufactured components;
- c) a technical specification of the precast structure with requirements for installation;
- d) there is an erection management to direct the erection team.

(3) This European standard presupposes that the work is carried out with the necessary skill and adequate equipment and resources to perform the work in accordance with this European Standard and the requirements of the execution specification.

NOTE In some countries, there are special requirements regarding the level of knowledge, training and experience of personnel involved in the various tasks.

(4) It is assumed that the constructor will comply with national regulations and standards e.g. with respect to:

- a) quality management;
- b) qualifications for the personnel doing the various activities covered by this standard;
- c) health and safety aspects of construction;
- d) environmental aspects.

(5) This standard assumes that the structure after completion is used as intended in the design and submitted to the planned inspection and maintenance necessary to achieve the intended design working life and to detect weaknesses or any unexpected behaviour.

4.2 Documentation

4.2.1 Execution specification

(1) Before commencement of execution of any part of the works, the execution specification relevant to that part of the works shall be complete and available.

(2) The following items shall be included in the execution specification:

- a) a reference to this European standard and, if published, and its National Annex;

- b) a reference to other relevant European standards and ETA's;
- c) a reference to relevant national regulations and standards;
- d) a project specification giving information and requirements for the particular project prepared to supplement and qualify the requirements of the above listed documents;
- e) drawings and other technical documents needed for the execution.

NOTE Informative Annex A, Table A.1 contains a checklist of requirements and information that may have to be included in the execution specification as appropriate. Informative Annex H gives guidance on the content of a national annex to this standard, a national annex may cover any of the areas referred to as open for specification by the execution specification.

- (3) In addition where relevant, procedures shall be established for:
- a) making alterations to previously agreed requirements;
 - b) the distribution, the filing and recording of technical documents used for the works.

4.2.2 Quality Plan

- (1) Where a quality plan is required by the execution specification, it shall be available at site.
- (2) There may be one quality plan covering all activities or one overall plan supplemented by separate plans for the various phases and activities to be performed.

4.2.3 Execution documentation

- (1) A record shall be made giving the required information as specified for the Execution Class in Tables 1, 2 and 3.

4.2.4 Special record documentation

- (1) If special documentation is required, the type and extent of the documentation shall be stated in the execution specification.

4.3 Quality Management

4.3.1 Execution classes

- (1) Supervision and inspection of the work shall verify that the construction is completed in accordance with the execution specification.
- (2) Inspection in this context refers to verifying conformity of the properties of products and materials to be used as well as inspection of the execution of the works.
- (3) Requirements for quality management are specified using one of the following 3 classes, for which the required strictness increases from class 1 to class 3:
- a) Execution Class 1;
 - b) Execution Class 2;
 - c) Execution Class 3.

(4) The execution class may refer to the complete structure, to components of the structure or to certain materials/technologies used for the execution.

(5) The execution class to be used shall be stated in the execution specification.

(6) This European Standard does not deal with provisions related to degree of independence of the personnel performing the inspection.

(7) Further detailing of the requirements for the quality management regime in excess of what is given in this document, may be stated in the execution specification.

NOTE Informative Annex B gives guidance on quality management.

4.3.2 Inspection of materials and products

(1) The inspection requirements for conformity with the execution specification are given in Table 1.

Table 1 — Inspection for materials and products

Subject	Execution Class 1	Execution Class 2	Execution Class 3
Materials for scaffold, formwork and falsework ^a	In accordance with 5.1 and 5.2		
Reinforcing steel ^a	In accordance with 6.2		
Prestressing system components ^a	Not to be used in this class	In accordance with 7.2	
Fresh concrete, ^{a, c} ready-mixed or site-mixed	In accordance with 8.1 and 8.3 At reception of ready-mixed concrete a delivery ticket shall be present		
Other items ^{a, b}	In accordance with the execution specification		
Precast elements ^a	In accordance with 9.2 and 9.3		
Inspection report	Not required	Required	
<p>^a Products bearing the CE mark or certified by an approved certification body shall be checked against the delivery ticket and visually inspected. In cases of doubt, further inspection shall be undertaken to check that the product conforms to its specification. Other products shall be subject to inspection and acceptance testing as defined in the execution specification.</p> <p>^b For example, items such as embedded steel components etc.</p> <p>^c If prescribed concrete is used, the relevant properties are to be checked by tests.</p>			

4.3.3 Inspection of execution

(1) The inspection requirements for conformity with the execution specification are given in Table 2 and Table 3.

Table 2 — Subjects for inspection of execution

Subject	Execution Class 1	Execution Class 2	Execution Class 3
Scaffolding, formwork and falsework	According to requirements given in 5		
Embedded items	According to requirements given in 5.6		
Ordinary reinforcement	According to requirements given in 6		
Prestressing reinforcement	Not to be used in this class	According to requirements given in 7	
Site transport and casting and curing of concrete	According to requirements given in 8		
Erection of precast elements	According to requirements given in 9		

Table 3 — Type and documentation of inspection

	Execution Class 1	Execution Class 2	Execution Class 3
Type of inspection	Visual inspection and random measurements	Visual inspection and systematic and regular measurements of major works	Visual inspection. Detailed inspection of all works which are significant for the load-bearing capacity and durability of the structure
Party which carries out the inspection	Self inspection	Self inspection Inspection in accordance with the procedures of the constructor Possible additional requirements by execution specification	Self inspection Inspection in accordance with the procedures of the constructor Additional requirements by execution specification
Extent	All works	In addition to the self inspection, there shall be a systematic and regular inspection of the works	In addition to the self inspection, there shall be a systematic and regular inspection of the works
Inspection report	Not required	Required	
As-built geometry	Not required	According to execution specification	

4.4 Action in the event of a non-conformity

(1) Where inspection reveals a non-conformity, appropriate action shall be taken to ensure that the structure is able to perform as designed.

(2) The following aspects shall be investigated in the listed order:

- a) the implications of the non-conformity on further execution and fitness for intended design purpose;
- b) the measures necessary to make the component acceptable;
- c) the necessity of rejection and replacement of the non-repairable component.

(3) If required in the execution specification, the rectification of non-conformity shall be in accordance with a procedure stated in the execution specification or as agreed.

5 Falsework and formwork

5.1 Basic requirements

(1) Falsework and formwork including their supports and foundations shall be designed and constructed so that they are:

- a) capable of resisting any foreseeable action to which they are submitted during the construction process;
- b) stiff enough to ensure that the tolerances specified for the structure are satisfied and the integrity of the structural member is not affected.

(2) The form, function, appearance and durability of the permanent works shall not be impaired or damaged due to the performance of the falsework, formwork and backpropping or their removal.

(3) Falsework and formwork shall comply with this standard and the relevant European Standard if available or be demonstrably fit for the intended use.

NOTE 1 Informative Annex C gives guidance on falsework and formwork.

NOTE 2 Falsework and formwork that comply with European Standards prepared for systems for temporary equipment should be deemed to satisfy this standard (e.g. EN 12812 and EN 12813).

5.2 Materials

5.2.1 General

(1) Any materials may be used provided that its use fulfils the criteria for the structure given in 5.1 and Clause 8. The material should comply with the relevant product standard or where none exists, the material may be used provided that the characteristics of the material are taken into account.

5.2.2 Release agents

(1) Release agents where used shall be selected and applied in such a way that they are not harmful to concrete, reinforcing steel, prestressing steel or formwork and in such a way that they have no detrimental effects on the permanent structure.

(2) Release agents shall have no unintended effect on the colour, surface quality of the permanent structure or specified subsequent coatings.

5.3 Design and installation of falsework

(1) A method statement, where required by the execution specification, shall give the design parameters/class adopted and describe the method of erection and dismantling of temporary structures including backpropping. It shall specify the requirements for handling, adjusting, intentional precambering, loading, unkeying, striking and dismantling.

(2) The design of the falsework shall take into account the deformation during and after concreting to prevent deleterious cracking in the young concrete.

(3) The layout of falsework shall not restrain the elastic deformation of the concrete during post-tensioning.

(4) Where the design of the finished permanent structure requires support of part of the structure until further parts or supporting structures, including backfilling, are completed, such requirements shall be stated in the execution specification.

5.4 Design and installation of formwork

(1) A method statement, where required by the execution specification, shall describe the methods of support, erection and dismantling. It shall specify the requirements for handling, adjusting, tying, intentional precambering, loading, unkeying, striking and dismantling.

(2) Formwork shall keep the concrete in its required shape until it is sufficiently hardened.

(3) Formwork and joints shall be sufficiently tight so as to minimize loss of fines.

(4) Formwork likely to absorb significant amounts of water from the concrete or facilitate evaporation shall be suitably treated to reduce water uptake from the concrete, unless intended specifically for that purpose.

(5) The internal surface of the formwork shall be clean. If the formwork is required by the execution specification to produce visible concrete surfaces, the treatment of the formwork surfaces shall be such that the specified finish is achievable.

(6) Where the design of the finished permanent structure requires a particular surface finish it shall be stated in the execution specification.

(7) Where the design of the finished permanent structure requires temporary support and/or specific deflection criteria it shall be stated in the execution specification.

(8) The formwork shall not restrain the elastic deformation of the concrete during post-tensioning.

(9) When using slipforming, the design of the system shall take into account the properties of the formwork material and make provision for controlling the geometry of the works.

5.5 Special formwork

(1) Requirements shall be given in the execution specification.

5.6 Inserts in formwork and embedded components

5.6.1 General

(1) Temporary inserts to keep the formwork in place, bars, ducts and similar items to be cast within the section and embedded components shall:

- a) be fixed robustly enough to ensure that they will keep their prescribed position during concreting;
- b) be provided with adequate corrosion protection;
- c) be of sufficient strength and stiffness to preserve their shape during the concreting operation;
- d) be given the specified concrete cover unless surface treated;
- e) not introduce unacceptable actions on the structure;
- f) not react harmfully with the concrete, the reinforcement or prestressing steel;
- g) not produce blemishes to the specified surface finish;

- h) not impair the functional performance and the durability of the structural member;
- i) not prevent adequate placing and compaction of the fresh concrete.

5.6.2 Making good of temporary recesses and holes

(1) Recesses and holes used for temporary works shall be filled and finished with a material of similar characteristics to the surrounding concrete, or as given in the execution specification.

5.7 Removal of formwork and falsework

(1) Falsework, backpropping and formwork shall not be removed until the concrete has gained sufficient strength:

- a) to resist damage to surfaces that may arise during the striking;
- b) to carry the actions imposed on the concrete member at that stage;
- c) to avoid deflections beyond the specified deviation in this standard and the execution specification;
- d) to avoid damage due to climatic effects.

(2) Striking shall be made in a manner that will not subject the structure to impact, overload or damage the permanent structure.

(3) The loads in falsework shall be released in a sequence that ensures the other falsework members and any supporting permanent constructions are not subject to excessive loads. The stability of falsework and formwork shall be maintained when loads are released and during dismantling.

(4) The sequence of removal, where backpropping and/or re-propping of the structure is used, shall be detailed in a method statement or the execution specification.

(5) If formwork is part of the curing system, the timing of its removal shall be taken into account in accordance with the requirements of 8.5.

6 Reinforcement

6.1 General

(1) The following clauses apply to prefabricated and site fabricated reinforcement.

NOTE Informative Annex D gives guidance on reinforcement.

6.2 Materials

(1) Reinforcing steel shall be in accordance with the requirements given in the execution specification. Properties shall be tested and documented in accordance with EN 10080. This applies also for stainless steel when used as reinforcement, unless otherwise specified by the execution specification.

NOTE The properties of reinforcement suitable for use with EN 1992-1-1:2004 are given in Annex C (Normative) of that standard. The classification of reinforcement may be given according to a national standard applicable in the place of use.

(2) Each product shall be clearly identifiable.

(3) Anchorage devices and couplers shall be used as specified by the execution specification.

(4) The surface of the reinforcement shall be free from loose rust and deleterious substances which may adversely affect the steel, concrete, or the bond between them. Light surface rust will be acceptable.

(5) When galvanised reinforcement is used the zinc coating shall be sufficiently passive to avoid chemical reactions with the cement, or the concrete shall be made with cement that has no detrimental effect on the bond to the galvanised reinforcement.

NOTE Natural passivation of zinc coating can be achieved by storing the zinc coated products outdoor for a period. Normally about 4 weeks is enough. Instant passivation can be achieved by dipping the coated products in passivation solution.

(6) Materials other than steel to be used as reinforcement such as composite carbon-, glass- or aramid fibre bars shall have an established suitability and be in accordance with the requirements given in the execution specification.

NOTE Suitability can be established by compliance with European Standards, European Technical Approvals, national standards or national provisions in the place of use.

(7) Chairs and spacers shall be suitable for achieving the specified cover to the reinforcement. Concrete and cementitious spacers should have at least the same strength and should at least give the same corrosion protection as the concrete in the structure.

NOTE Steel spacers in direct contact with the concrete surface are only permitted in a dry environment i.e. exposure class X0 and XC1 of EN 206-1.

6.3 Bending, cutting, transport and storage of the reinforcement

(1) The cutting and bending of reinforcing steel shall conform to the execution specification; bent bars shall be without cracks and other damage. The following requirements apply:

- a) bending shall be done in one operation. When using automated bending machines it may be continuous or incremental.
- b) bending of steel at temperatures below -5°C is permitted only if allowed by the execution specification and provided the procedure conforms to given additional precautions;
- c) unless permitted by the execution specification, bending by heating the bars is not permitted.

NOTE Bar schedules for cutting and bending of reinforcement should be in accordance with EN ISO 3766.

(2) For bending bars, the diameter of the mandrel used shall be in accordance with the execution specification.

(3) For welded reinforcement and fabric bent after welding, the diameter of the mandrel used shall be in accordance with the execution specification.

(4) Steel reinforcing bars, welded fabric and prefabricated reinforcement cages shall not be damaged during transporting, storing, handling and placing into position and shall be stored clear of the ground.

(5) Straightening of bent bars is not allowed unless permitted by the execution specification and, in such cases:

- a) the mandrel used for the original bend is at least twice the minimum mandrel allowed for that steel, unless a smaller mandrel diameter is documented by a rebend test in accordance with EN 10080;
- b) if a smaller mandrel diameter is documented by a rebend test in accordance with EN 10080 the actual bending diameter should be not less than 1,3 times the test diameter in the rebend test;
- c) special equipment to limit local stresses shall be used;

- d) a procedure for straightening shall be prepared;
- e) straightened bars are inspected visually for cracks or other damage.

NOTE The requirements above do not exclude the use of type tested products where the original bend is that which can be documented by a test of tensile strength, demonstrating a tensile strength as required for the actual grade of steel, after a procedure of bending, aging and straightening.

(6) Reinforcement from coils shall not be used unless appropriate equipment is available and the straightening procedures are in accordance with the manufacturer's instructions. The de-coiled and straightened bars shall meet the requirements for the reinforcement given in the relevant standards, after straightening, and tested as specified in EN 10080.

6.4 Welding

(1) Welding is permitted on reinforcing steel classified as weldable unless otherwise specified in the execution specification.

(2) Welding of reinforcing steel, and welding of reinforcing steel to structural steel, in loadbearing joints shall be performed as specified in the execution specification, and in accordance with EN ISO 17660-1 unless otherwise specified.

(3) Spot welding of non-loadbearing welds performed according to EN ISO 17660-2 is permitted unless otherwise specified in the execution specification.

6.5 Joints

(1) The reinforcement shall be placed according to the execution specification, which shall give details of cover, spacing, joints, overlaps, lap lengths and layout of bars.

NOTE Special attention should be given to reinforcement and cover at the location of holes of small dimensions which are not considered in the structural design.

(2) Where permitted by the execution specification the reinforcement may be placed as "*running metres*". In such cases the laps shall be well distributed, maximum 25 % lapped in the same section, and the longitudinal distance between two adjacent laps should not be less than the lap length, the minimum lap length shall be stated.

NOTE This system is only used in cases where the actual position of overlapping joints is not of importance i.e. secondary reinforcement in walls and slabs, but not in beams or columns or joints between structural members.

(3) The reinforcement shall be fixed and secured so that its final position is within the tolerances given in this standard. The assembly of reinforcement may be done with tie wire or spot welding (see 6.4 (3)). Unless otherwise specified overlapping bars should be placed in contact, and in beams and columns the laps should in general be tied.

(4) The specified cover applies to the nominal value, c_{nom} , and applies to the surface of any reinforcement including possible assembly reinforcement.

7 Prestressing

7.1 General

(1) The following requirements apply to prestressed concrete construction including:

- a) bonded pre-tensioned construction;

- b) bonded post-tensioned construction;
- c) unbonded post-tensioned, internal or external construction.

NOTE Informative Annex E gives guidance on prestressing.

(2) This standard assumes that the work is performed by adequately experienced specialist companies. Additional requirements for the installation of post-tensioning kits for prestressing of structures and qualification of the specialist company and its personnel, may be stated in the execution specification.

NOTE Guidance can be found in CEN Workshop Agreement CWA 14646.

7.2 Materials for prestressing

7.2.1 Post-tensioning systems

(1) Post-tensioning systems shall hold a European Technical Approval (ETA) and be in accordance with the requirements given in the execution specification.

(2) All parts of the post-tensioning system shall be compatible e.g. from the same prestressing system.

NOTE Guidance on requirements concerning post-tensioning kits for prestressing of structure can be found in ETAG 013.

7.2.2 Sheaths

(1) Steel strip sheaths shall conform to EN 523.

(2) Sheaths of materials other than steel shall be in accordance with the European Technical Approval for the prestressing system.

NOTE In CEN documents the term "duct" is also used instead of "sheath".

7.2.3 Tensile elements

(1) The prestressing steel (wires, strands, bars) shall conform to EN 10138²⁾ and be in accordance with the requirements given in the execution specification.

(2) Materials other than steel to be used for prestressing shall be in accordance with the requirements given in the execution specification.

NOTE At the time of publishing this standard, there are no European standards or ETAGs covering the design, specification and application for materials other than steel (e.g. carbon-, glass- or aramid fibres).

7.2.4 Anchorage elements and accessories

(1) Anchorage components for the prestressing system shall be those specified in the European Technical Approval.

7.2.5 Tendon supports

(1) Tendon supports shall:

2) European Standard for prestressing steels (EN 10138) is presently in preparation. Until it is issued and implemented, national standards apply. In lack of national standards, ISO 6934 may be applied.

- a) not be deleterious to either steel or concrete;
- b) be stiff enough to ensure a stable fixing of the tendons in their required position during concreting;
- c) not damage the sheaths.

(2) The spacing of the tendon supports shall be such as to ensure the sheaths conform to the required line and level.

7.2.6 Cement-based grout

(1) Grout for filling ducts and anchorages shall conform to EN 446 / EN 447.

7.2.7 Grease, wax or other products

(1) Grease or wax for filling ducts and anchorages of unbonded tendons shall be as specified in the European Technical Approval.

7.3 Transport and storage

(1) Materials sensitive to corrosion e.g. prestressing steel, sheaths, anchorage devices, couplers, prefabricated tendons and tendons fabricated on site, shall be protected from harmful influences during transport and storage and also whilst placed in the structure prior to permanent protection. Materials that have corroded to an extent which is likely to impair their performance shall be replaced by conforming materials.

NOTE The ETA holder will provide relevant instructions related to transportation, storage and handling (See ETAG 013).

(2) Materials for grout shall be protected from water and moisture during delivery and storage on site and shall be used within the specified shelf life.

7.4 Installation of tendons

7.4.1 General

(1) The prestressing tendons shall be assembled, placed and secured in accordance with the European Technical Approval and as specified in the execution specification. It shall follow a smooth line without sags or kinks and within the permissible tolerances (see 10.6).

(2) The type and class of prestressing steel and source documentation for all components shall be recorded in the inspection record documentation.

(3) Welding of prestressing steel or anchorages is not permitted. Oxygen cutting or welding of steel in the vicinity of prestressing steel is not permitted unless under conditions stated in the execution specification. Welding of local anchorage zone reinforcement, anchor plates and spot welding of perforated plates is not permitted unless under conditions stated in the execution specification.

(4) All joints in sheaths, anchorages and couplers shall be sealed against the ingress of water.

(5) Care shall be taken to prevent twisting or crossing of strands both in assembly and installation.

7.4.2 Pre-tensioned tendons

(1) Any de-bonded lengths of the prestressing steel shall be adequately protected against corrosion.

7.4.3 Post-tensioned bonded tendons

- (1) Vents on the sheaths shall be provided at both ends and at the points of the tendon where air or water may accumulate. Vents or inlets will normally be required at intermediate positions.
- (2) Vents shall be properly marked to identify the cable.
- (3) The sheaths and vents shall be secured to withstand the effects of placing and compacting of the concrete.

7.4.4 Internal and external unbonded tendons

- (1) Unbonded tendons shall be adequately sealed throughout their length against penetration of moisture.

7.5 Tensioning

7.5.1 General

- (1) Tensioning shall conform to a prearranged and approved tensioning programme. Force (pressure) and elongation shall be recorded in an inspection record document.

NOTE The ETA specifies the maximum force for the system.

- (2) Written instructions for the tensioning shall be available on site.
- (3) Jacking anchorages as well as dead end anchorages shall be as shown in the drawings.
- (4) Stressing equipment shall be selected from those permitted by the European Technical Approval for the system.
- (5) The valid calibration records for the force measuring devices shall be available on site before the tensioning starts.
- (6) Application and/or transfer of prestressing to a structure is only allowed when the concrete strength is equal to or greater than the minimum compressive strength specified in the execution specification.

NOTE The ETA for the particular prestressing system will give minimum required compressive strength of concrete to allow full prestressing of tendons, P_{max} .

- (7) The results of the tensioning programme and its conformity or non-conformity to the requirements shall be recorded in an inspection report.

NOTE Guidance on common practice is given in E.7.5.

7.5.2 Pre-tensioned tendons

- (1) If during the stressing of pre-tensioning tendons to the specified force, the actual elongation of the group of all tendons at a particular cross-section of the structure is not within $\pm 3\%$ of the calculated elongation, or of a single tendon is not within $\pm 5\%$ of the calculated elongation, action shall be taken in accordance with the execution specification.
- (2) If the fresh concrete cannot be cast in due time after tensioning, temporary protective measures shall be taken which will not have a detrimental effect on the steel and/or the concrete. It shall be verified that any reduction of bond due to the temporary protective measure is acceptable for the design of the structure.

7.5.3 Post-tensioned bonded tendons

(1) If during the stressing of post-tensioning tendons to the specified force, the actual elongation of the group of all tendons at a particular cross-section of the structure is not within $\pm 5\%$ of the calculated elongation, or of a single tendon in a group is not within $\pm 15\%$ of the calculated elongation, action shall be taken in accordance with the execution specification.

(2) In the case of deviation from the planned performance during tensioning, the cutting off of tendon ends or grouting is not permitted. Work, which can impair the re-tensioning, shall not be carried out. Such work shall be postponed until the causes have been investigated and a revised tensioning report has been approved.

7.5.4 Internal and external unbonded tendons

(1) 7.5.3 applies.

7.6 Protective measures (grouting, greasing)

7.6.1 General

(1) Written instructions shall be provided for the preparation and execution of the protective measures against e.g. corrosion, frost and mechanical damages.

(2) Grouting equipment shall be in accordance with EN 446 and be selected from those permitted by the European Technical Approval (ETAG 013).

(3) Results from the inspection and whether the work conforms to the requirements for the protection shall be recorded in the inspection report, see 4.3 and Annex E.

(4) Anchorage areas and end caps shall be protected as well as the tendons.

(5) If permanent protection cannot be applied within due time after installation or tensioning of the tendons, temporary protective measures shall be taken (see Annex E and EN 446).

7.6.2 Pre-tensioned tendons

(1) The ends of the tendons shall be protected against corrosion under service.

7.6.3 Post-tensioned bonded tendons

(1) Grouting of post-tensioned bonded tendons shall conform to EN 446.

7.6.4 Internal or external unbonded tendons

(1) Where external tendons are to be protected by grout, grout and grouting shall conform to 7.6.3.

(2) In other cases, the sheaths and anchorages of the tendons shall be filled by the specified method with a non-corrosive grease or wax conforming to European Technical Approval (ETA).

7.6.5 Grouting operations

(1) The mixing process (batching, w/c ratio, procedure, time etc.) shall be in accordance with EN 446 and EN 447.

(2) Grouting shall be performed in accordance with EN 446.

(3) If grouting cannot be performed in due time after tensioning, temporary protective measures shall be taken which will not have a detrimental effect on the prestressing steel and/or the grout. It shall be verified that any reduction of bond due to the temporary protective measure is acceptable for the design of the structure.

7.6.6 Greasing operations

(1) Injection of grease or wax shall be carried out at a continuous and steady rate.

(2) The volume injected shall be comparable with the theoretical free volume in the duct. The change of volume with temperature shall be taken into account.

(3) After completion of injection, unintended loss of grease or wax from the ducts shall be prevented by sealing them under pressure.

(4) Materials, connections and equipment shall be suitable for the temperature range needed for injection of grease or wax. Special safety precautions may be necessary for works at elevated temperatures.

7.6.7 Sealing

(1) Anchorages shall be sealed after grouting to assure a corrosion protection equivalent to that provided along the tendon (e.g. sufficient depth of dense, low permeability concrete, or cap, or combination of measures).

(2) Anchorage zones shall be protected from drainage water.

(3) All vents and grout inlets and outlets shall be suitably sealed and protected.

8 Concreting

NOTE Informative Annex F gives guidance on concreting.

8.1 Specification of concrete

(1) Concrete and its specification shall comply with EN 206-1.

(2) The concrete specification shall include requirements given in the execution specification and requirements related to the actual method of execution.

(3) The actual upper sieve size D of the aggregate to be used in the concrete shall not be less than that given in the execution specification.

NOTE See F.8.1.

(4) Information on concrete strength development shall be obtained from the concrete producer when required for the execution of the concrete works, e.g. deciding curing class.

8.2 Pre-concreting operations

(1) A concreting plan shall be prepared where required by the execution specification.

(2) Initial testing of concreting by trial casting shall be performed where required by the execution specification. The results of these tests shall be documented before the start of the execution.

(3) All preparatory works shall be completed, inspected and documented as required for the actual Execution Class before the casting is initiated.

- (4) Construction joints shall be prepared in accordance with the requirements given in the execution specification; they shall be clean, free of laitance, and wetted to a damp condition.
- (5) The form should be free of detritus, ice, snow and standing water.
- (6) Where concrete is placed directly against ground, the fresh concrete shall be protected against intermixing with the substrate.
- (7) Where there is risk that rain or other flowing water can wash out the cement and fines of the fresh concrete during casting, precautions shall be planned to protect the concrete against damaging effects.
- (8) Ground, rock, formwork or structural parts in contact with the section to be cast shall have a temperature which does not result in freezing of the concrete before it has sufficient strength to resist the effects of freezing.
- (9) Where the ambient temperature is low, or forecast to be low at the time of casting or in the curing period, precautions shall be taken to protect the concrete against damage due to freezing.
- (10) Where the ambient temperature at the time of setting and curing is likely to be high, precautions shall be planned to protect the concrete against damaging effects.

8.3 Delivery, reception and site transport of fresh concrete

- (1) The receiving inspection shall comprise a check of the delivery ticket prior to discharge.
- (2) The concrete shall be visually inspected during unloading. Unloading shall be stopped if the appearance, judged by experience, is not normal.
- (3) Detrimental changes of the fresh concrete, such as segregation, bleeding, paste loss or any other changes shall be minimised during loading, transport and unloading as well as during conveyance on site.
- (4) Where required by the execution specification, samples for testing shall be taken at the point of placing or in the case of ready-mixed concrete, at the point of delivery.

NOTE Test methods and criteria for determining the conformity and identity of concrete to EN 206-1 are given in that standard.

- (5) Fresh concrete shall not come into contact with aluminium alloy, unless permitted by the execution specification and gas generation is not considered to be a problem.

8.4 Placing and compaction

8.4.1 General

- (1) The concrete shall be placed and compacted in order to ensure that all reinforcement and cast-in items are properly embedded and that the concrete achieves its intended strength and durability.
- (2) Particular care in ensuring proper compaction is required at changes in cross-sections, in narrow locations, at box-outs, at congested reinforcement arrangements and at construction joints.
- (3) The rate of placing and compaction shall be high enough to avoid cold joints and low enough to prevent excessive settlements or overloading of the formwork and falsework.

NOTE A cold joint may form during casting if the concrete on the casting front sets before placing and compaction of the next layer of concrete. Particular attention is required when revibration of the joint is not possible.

- (4) Additional requirements on the placing method and rates of placing may be needed where there are special requirements for the surface finishes.

(5) Segregation shall be minimised during placing and compaction.

(6) The concrete shall be protected against adverse effects of solar radiation, strong wind, freezing, water, rain and snow, during placing and compaction.

8.4.2 Lightweight Aggregate Concrete

(1) Where lightweight aggregate concrete is to be pumped, documentation shall be available showing that pumping will have no significant effect on the strength of the hardened concrete.

NOTE A strength loss would reflect a weakening of the transition zone between the paste and the lightweight aggregates due to water squeezed in and out of the aggregate during and after pumping. A remixing of the concrete after pumping could compensate for the effect.

8.4.3 Self Compacting Concrete

(1) By the use of concrete described as Self Compacting Concrete (SCC), the compaction of the fluid concrete is achieved due to the effect of gravity. Working procedures for the actual cast shall be established, based on the constructor's experience and/or pretesting, to enable the required compaction to be obtained. Additional requirements to those given in EN 206-1 to the fresh concrete properties and its conformity criteria, if any, shall be agreed with the producer.

8.4.4 Sprayed concrete

(1) For concrete placed by spraying the execution of the work shall comply with the requirements given in EN 14487 Part 1 and Part 2 and as specified in the execution specification.

NOTE EN 14487-2 gives requirements for the information and the technical requirements to be included in the execution specification.

8.4.5 Slipforming

(1) Concrete for slipforming shall have an appropriate consistency and set. Slipforming shall be performed with appropriate equipment and methods ensuring that the specified cover to the reinforcement, concrete quality and surface finish are achieved.

(2) The execution specification, for instance the detailing of the reinforcement, and the actual slipforming equipment shall be compatible.

8.4.6 Underwater concreting

(1) Underwater concreting shall be executed with adequate equipment and methods ensuring that the requirements specified in the execution specification are fulfilled.

(2) The execution specification, for instance the detailing of the reinforcement, and the actual method of concreting shall be compatible.

8.5 Curing and protection

(1) Concrete in its early life shall be cured and protected:

- a) to minimise plastic shrinkage;
- b) to ensure adequate surface strength;
- c) to ensure adequate surface zone durability;

- d) from harmful weather conditions;
- e) from freezing;
- f) from harmful vibration, impact or damage.

(2) If concrete in its early life needs to be protected against harmful contact with aggressive agents (e.g. chlorides), such requirements shall be stated in the execution specification.

(3) Methods of curing shall achieve low evaporation rates from the concrete surface or keep the surface permanently wet, guidance is given in Annex F.

Natural curing is sufficient when conditions throughout the required curing period are such that evaporation rates from the concrete surface are low, e.g. in damp, rainy or foggy weather.

(4) On completion of compaction and finishing operations on the concrete, the surface shall be cured without delay. If needed to prevent plastic shrinkage cracking on free surfaces, temporary curing shall be applied prior to finishing.

(5) If concrete with low bleeding tendency is used, e.g. high strength concrete and self-compacting concrete, special considerations shall be given to prevent plastic shrinkage cracking. This applies also for concreting under weather conditions that cause strong evaporation like hot weather, wind as well as in cold and dry air.

(6) The duration of applied curing shall be a function of the development of the concrete properties in the surface zone.

This development is described by curing classes defined by curing period or percentage of the specified characteristic 28 day compressive strength, according to Table 4.

Table 4 — Curing Classes

	Curing class 1	Curing class 2	Curing class 3	Curing class 4
Period (hours)	12 ^a	NA	NA	NA
Percentage of specified characteristic 28 days compressive strength	Not applicable (NA)	35 %	50 %	70 %
^a Provided the set does not exceed 5 hours, and the surface concrete temperature is equal to or above 5 °C				

(7) The curing class to be used shall be stated in the execution specification.

(8) Special curing requirements (higher than 70 %) may be given in the execution specification.

(9) Recommendations on curing methods and minimum curing times are given in informative Annex F.

(10) Curing compounds are not permitted on construction joints, on surfaces to be treated or surfaces where bonding of other materials is required, unless they are fully removed prior to the subsequent operation, or they are proven to have no detrimental effects on the subsequent operations.

(11) Curing compounds shall not be used on surfaces with special requirements for the surface finish unless they are proven to have no adverse effects.

(12) The concrete surface temperature shall not fall below 0 °C until the concrete surface compressive strength has reached a minimum value of 5 MPa.

(13) Unless specified otherwise, the peak temperature of the concrete within a component exposed to wet or cyclic wet environment shall not exceed 70 °C, unless data is provided to prove that, with the combination of materials used, higher temperatures will have no significant adverse effect on the service performance of the concrete.

NOTE If concrete is exposed to high temperature over a certain period in its early life, delayed ettringite formation can occur depending on humidity and concrete mix design (alkali content, chemical composition of cement, use of additions etc.).

(14) Requirements related to accelerated curing by application of external or internal heat are not given in this standard.

(15) A possible strength loss has to be taken into account when high temperature curing is used.

(16) The execution specification may include requirements to reduce the possibility of early age thermal cracking (e.g. use of low heat concrete, cooling pipes, insulation etc.).

8.6 Post-concreting operations

(1) After form striking, all surfaces shall be inspected in accordance with the Execution Class for conformity to the requirements.

(2) The surface shall not be damaged or disfigured during construction.

8.7 Concreting of composite structures

(1) Concreting of composite structures shall conform to this standard.

8.8 Surface Finish

(1) Requirements, if any, for the finish of formed and unformed surfaces shall be given in the execution specification.

9 Execution with precast concrete elements

9.1 General

(1) This clause gives requirements for the construction operations involving structural precast elements from their reception at the site or, in the case of site manufactured elements from removal from the forms, until the completion of their installation and final acceptance.

(2) Precast elements shall be used as specified in the execution specification and the design coordination between them and the structural performance of the overall structure shall be verified.

9.2 Factory produced precast elements

(1) The factory produced precast elements, up to the receipt of the elements at the site, are in the scope of the relevant European product standards (precast products).

(2) The provisions of this standard apply to the manufacturing of precast elements not conforming to the relevant European product standard.

9.3 Site manufactured precast elements

- (1) Site manufactured elements may be treated as precast products if they conform to the relevant European product standards.
- (2) Site manufacturing of elements which are not conforming to any European product standard shall not be considered as precast products, and their manufacture is covered by this standard.
- (3) The requirements for operations following the production of site manufactured precast elements are the same as for factory produced precast elements.

9.4 Handling and storage

9.4.1 General

- (1) Handling, storage and protection of the precast elements shall be carried out in accordance with the execution specification.
- (2) The total weight shall be available for each precast element.
- (3) Marking for product identification shall be available on each precast element and, where required by the execution specification, the relevant position of each precast element within the works.

NOTE See EN 13369 for marking of precast products.

9.4.2 Handling

- (1) A lifting scheme defining the suspension points and forces, the arrangement of the lifting system and, where necessary, any special provisions shall be available.

9.4.3 Storage

- (1) Storage instructions for the precast element shall define the storage position and the permissible support points, the maximum height of the stack, the protective measures and, where necessary, any provisions required to maintain stability.

9.5 Placing and adjustment

9.5.1 General

- (1) Before any delivery of precast elements, the erection specification necessary for their handling and possible on site storage shall be available at site.
- (2) Requirements for the placing and adjustment of the precast elements shall be given in the erection specification.
- (3) The work programme with the sequence of on-site operations shall be available at site.
- (4) Erection shall not be started until the above items are satisfactorily verified.

9.5.2 Placing

- (1) The erection specification shall define the arrangement of the supports, the necessary props and, where necessary, the temporary stability provisions.

NOTE The normal content of an erection specification is given in EN 13369, see also 10.5 (3)

(2) Where necessary, the access and work positions shall be shown in the erection specification for the guiding of any precast element and the reach and capacity of lifting devices.

(3) Construction measures are to be applied which ensure that supports remain stable during construction and which minimise the risk of damage to such supports.

NOTE Special advice may be required to ensure safe installation and to avoid accidental damage. For beams and slabs minimum support lengths and edge distances should be specified in a manner that facilitates both easy installation and easy inspection.

(4) The erection of the precast elements shall conform to the erection and execution specification and the operation sequence of the work programme.

(5) During installation, the correct position of the precast elements, the dimensional accuracy of the supports, the conditions of the joints and the overall arrangement of the structure shall be checked and any necessary adjustments made.

9.6 Jointing and completion works

9.6.1 General

(1) An inspection of the erection shall be carried out before the execution of jointing and before any completion works.

(2) The completion work shall be carried out on the basis of the requirements given in the erection specification and taking climatic conditions into account.

9.6.2 In-situ works

(1) The placing of any additional reinforcement for the completion of the structure shall conform to Clauses 6 and 7.

(2) The in-situ concreting shall conform to Clause 8.

9.6.3 Structural connections

(1) Connections of any type shall be used in accordance with manufacturer's instructions.

(2) Threaded and glued connections shall be executed according to the specific technology of the materials used.

(3) The execution specification should contain requirements to ensure that:

- a) joints have a size compatible with the sealing method;
- b) steel inserts of any type, used for joint connections, are properly protected against corrosion and fire by an appropriate choice of materials or covering;
- c) welded structural connections are made with compatible weldable materials and are inspected.

10 Geometrical tolerances

10.1 General

(1) The completed structure shall be within the maximum allowable deviations to avoid detrimental effects in terms of:

- a) mechanical resistance and stability in transient and in service stages;
- b) service performance during the use of the construction works;
- c) placing compatibility for the erection of the structure and its non-structural components.

Deviations from the specified tolerance range shall be handled in accordance with 4.4. Small deviations which have no significant consequence on the performance of the finished structure may be ignored.

(2) This clause contains the types of geometrical deviations relevant to building structures. They may be applied also for civil engineering works, as relevant, or amended in the execution specification. Numerical values are given for structural tolerances, i.e. tolerances that have influence on the structural safety. Two structural tolerance classes are identified for geometrical tolerances. Unless otherwise stated in the execution specification, tolerance class 1 applies.

NOTE 1 Tolerance class 1 is considered as normal tolerances (see 3.23). The tolerances given in 10.4 to 10.6, tolerance class 1, achieves the design assumptions of EN 1992 and the required level of safety and are related to partial factors of materials given in clause 2.4.2.4 of EN 1992-1-1:2004. These are considered essential for the mechanical resistance and stability of structures in order to fulfil 10.1(1) a. Tolerance class 2 is primarily intended to be used with reduced material factors in EN 1992-1-1:2004, Annex A.

NOTE 2 Where tolerances are specified according to class 2 in Figure 4a and Figure 4b and reduced material factors according to Annex A of Eurocode 2 are used in the design, the execution specification should request documentation that the assumptions made in the design are actually fulfilled in the finished structure.

(3) Values for permitted geometrical deviations in terms of service performance and placing compatibility may be given in the execution specification. Recommended values are given in informative Annex G. Unless otherwise specified the tolerances given in Annex G apply.

(4) Any requirements for special tolerances shall be identified in the execution specification and the following information shall then be given:

- a) any amendments to the permitted deviations given in this standard;
- b) any further type of deviation to be controlled, together with defined parameters and permitted values;
- c) whether these special tolerances apply to all relevant components or to particular components which are identified;
- d) if the "box principle" shall be applied, and what deviation is permitted, see 10.1 (5).

(5) The "box principle" will require that all points of the structure are within the specified theoretical position with a margin in any direction corresponding to the permitted deviation. A recommended value when applying the box principle is ± 20 mm.

(6) Tolerances for surfaces between components where forces are intended to be transmitted by full contact bearing between the surfaces are not defined in this standard. Any requirements to such surfaces shall be stated in the execution specification.

(7) Tolerances for components cast under water are not given in this standard.

(8) If a certain geometrical deviation is covered by different requirements, the strictest tolerance is applicable.

(9) The requirements of this clause relate to the completed structure. Where components are incorporated in a structure, any intermediate checking of such components shall be subordinate to the final checking of the completed structure.

(10) This standard does not give requirements for the combination of construction tolerances and structural deformations. Permitted deviations are valid for the situation before deformations caused by loading and time dependent effects takes place, unless otherwise specified in the execution specification, see 10.1 (4).

10.2 Reference system

- (1) Tolerances of position in plane refer to the secondary lines in plane.
- (2) Tolerances of position in height refer to the secondary lines in height e.g. a transferred bench mark.
- (3) Any requirement for the secondary lines shall be stated in the execution specification.

NOTE ISO 4463-1 gives guidance for setting-out the secondary lines.

10.3 Base supports (foundations)

(1) Base supports may be direct foundations on the ground, pile caps etc. Recommended values for the position of the centres of the base supports are given in Figure G.1 in Annex G.

NOTE Foundation on the ground may be either cast directly or made from precast concrete elements. Tolerance requirements to deep foundations, such as piles, slurry walls, diaphragms, special anchorages etc., are not given in this standard.

10.4 Columns and walls

(1) Values for permitted structural deviations for columns and walls are given in Figure 2.

NOTE Guidance for permitted deviations for the positions of columns and walls measured relative to the secondary lines is given in Figure G.2 in Annex G.

No	Type of deviation	Description	Permitted deviation Δ
Tolerance Class 1			
a	 <p>h - free height</p>	Inclination of a column or wall at any level in a single- or a multi-storey building $h \leq 10$ m $h > 10$ m	The larger of 15 mm or $h/400$ 25 mm or $h/600$
b	 <p>$t = (t_1 + t_2)/2$</p>	Deviation between centres	The larger of $t/30$ or 15 mm but not more than 30 mm
c		Curvature of a column or wall between adjacent storey levels	The larger of $h/300$ or 15 mm but not more than 30 mm
d	 <p>Σh_i - sum of height of storeys considered</p>	Location of a column or a wall at any storey level, from a vertical line through its intended centre at base level in a multi-storey structure n is the number of storeys, where $n > 1$	The smaller of 50 mm or $\Sigma h_i / (200 n^{1/2})$

Figure 2 — Permitted vertical deviations for columns and walls

10.5 Beams and slabs

- (1) The given deviations for the line and level of beams and slabs also apply to other horizontal and sloping structural components.
- (2) Values for permitted structural deviations for beams and slabs are given in Figure 3.
- (3) Tolerances for bearing length of precast beams and slabs are not given in this standard, they shall be given in the erection specification or by technical information on the precast element.

No	Type of deviation	Description	Permitted deviation Δ
			Tolerance Class 1
a	 <p>1 - beam, section 2 - column, elevation</p>	<p>Location of a beam-to-column-connection measured relative to the column</p> <p>$b =$ dimension of column in the same direction as Δ</p>	<p>The larger of</p> <p>$\pm b/30$</p> <p>or</p> <p>± 20 mm</p>
b	 <p>1 - actual bearing axis of support</p>	<p>Position of bearing axis of support when structural bearings are used</p> <p>$\ell =$ Intended distance from edge</p>	<p>The larger of</p> <p>$\pm \ell/20$</p> <p>or</p> <p>± 15 mm</p>

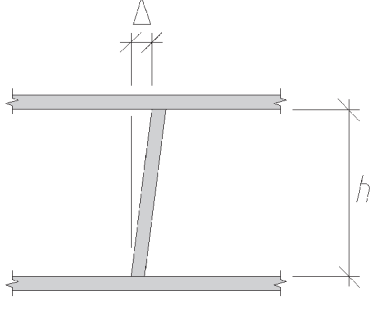
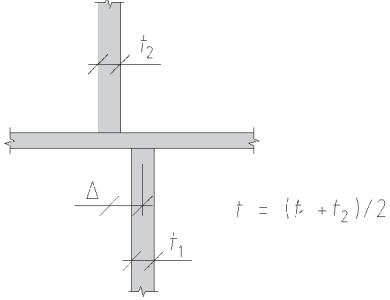
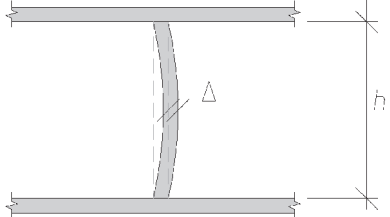
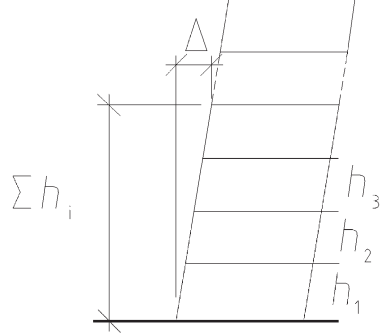
Figure 3 — Permitted deviations for beams and slabs

10.6 Sections

(1) The dimensions of cross-section, the cover and position of reinforcement and prestressing reinforcement shall not deviate more from the nominal values than given in Figure 4.

NOTE The values for deviations given do not apply to precast products. They should conform to the relevant product standard.

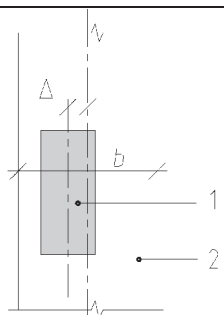
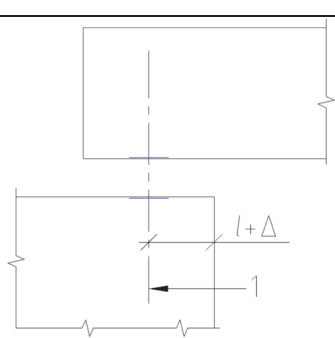
(2) Conformity with the cover requirements shall be assessed for each individual reading unless provisions valid at the construction site permit a statistical approach.

No.	Type of deviation	Description	Permitted deviation Δ	
			Tolerance Class 1	Tolerance Class 2
				see 10.1(2) Notes
a	<p>l_i - length of cross-sectional dimension</p>	<p>Cross-sectional dimensions</p> <p>Applicable to beams, slabs and columns</p> <p>For $l_i < 150$ mm $l_i = 400$ mm $l_i \geq 2500$ mm</p> <p>with linear interpolation for intermediate values</p>	<p>± 10 mm ± 15 mm ± 30 mm</p>	<p>± 5 mm ± 10 mm ± 30 mm</p>
<p>NOTE 1 For foundations, permitted plus-deviations shall be stated in the execution specification, if required. Minus-deviations are as stated.</p> <p>NOTE 2 Tolerances for special geotechnical concrete members cast directly into the ground are not covered by this standard, e.g. slurry-walls, bored piles, etc. However, ordinary, normal foundations cast directly onto the ground are covered (i.e. blindings etc.).</p>				

Figure 4 — Permitted sectional deviations

No.	Type of deviation	Description	Permitted deviation Δ	
			Tolerance Class 1	Tolerance Class 2
b	 <p>Requirement:</p> $c_{nom} + \Delta c_{(plus)} > c > c_{nom} - \Delta c_{(minus)} $	Location of ordinary reinforcement $\Delta c_{(plus)}$ $h \leq 150 \text{ mm},$ $h = 400 \text{ mm},$ $h \geq 2500 \text{ mm},$ with linear interpolation for intermediate values	 + 10 mm + 15 mm + 25 mm ^b	 + 5 mm + 10 mm + 20 mm
	c_{min} = required minimum cover c_{nom} = nominal cover = $c_{min} + \Delta c_{(minus)} $ c = actual cover Δc = permitted deviation from c_{nom} h = height of cross-section	$\Delta c_{(minus)}$	Δc_{dev}^a	Δc_{dev}^a
<p>^a Δc_{dev} can be found in national annex to EN 1992-1-1. Unless otherwise specified, $\Delta c_{dev} = 10 \text{ mm}$. The execution specification may state if a statistical approach allowing a certain percentage of values with covers less than c_{min} is permitted.</p> <p>^b Permitted plus-deviations for cover to reinforcement for foundations and concrete members in foundations may be increased by 15 mm. The given minus-deviations apply.</p>				

Figure 4 — (continued)

No.	Type of deviation	Description	Permitted deviation Δ
			Tolerance Class 1
c		Lap-joints $l = \text{Lap length}$	$- 0,06 l$
d	 <p>Longitudinal section; y - nominal position (normally a function of position x) along the prestressing tendon)</p>	Location of prestressing reinforcement ^{a)} For $h \leq 200 \text{ mm}$ For $h > 200 \text{ mm}$: Concrete cover measured to sheath $\Delta c_{(\text{minus})}$	$\pm 6 \text{ mm}$ The smaller of $\pm 0,03 h$ or $\pm 30 \text{ mm}$ $\Delta c_{\text{dev}}^{\text{b)}}$
<p>^a The values given apply to thickness and transverse direction. For transverse direction h is the width of the element. For tendons in slabs larger deviations than $\pm 30 \text{ mm}$ may be permitted if necessary to avoid small openings, ducts, chases and inserts. The tendon profile of such deviations shall be smooth.</p> <p>^b Permitted minus-deviation Δc_{dev} as for ordinary reinforcement, see case b.</p>			

Figure 4 — (continued)

10.7 Surfaces and edge straightness

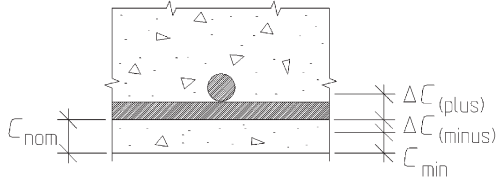
Recommended values for deviations for surfaces and straightness are given in Figure G.5 in Annex G.

10.8 Tolerances for holes and inserts

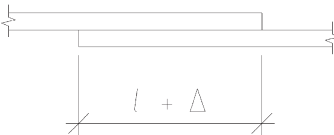
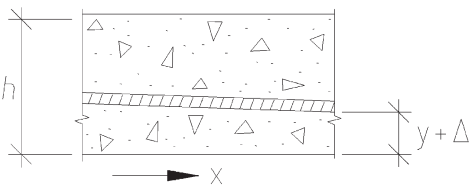
Recommended values for deviations for holes, block-outs, recesses and inserts are given in Figure G.6 in Annex G.

Annex A (informative)

Guidance on documentation

Main clause numbers mirror those in Clause 4.2: Documentation

A.4.2.1 Execution specification

- (1) The execution specification should include:
- a) Description of all products to be used with any requirement for the application of the products. This information should be given on the drawings and/or in the project specification.
 - b) Project specification, which is the document that describes the Execution classes to be applied, any special tolerance, requirements for the properties of surface finish etc. A checklist for information to be included is given in Table A.1. The project specification should also include all requirements for execution of the work, i.e. sequence of operations, temporary supports, work procedures etc.
 - c) Construction drawings, giving all necessary information such as:
 - 1) geometry of the structure;
 - 2) amount and position of reinforcing and prestressing steel;
 - 3) for precast concrete elements, lifting devices, weights, inserts, etc.
 - d) Where relevant, an erection specification for precast concrete elements. An erection specification should include:
 - 1) installation drawings consisting of plans and sections showing the positions and the connections of the elements in the completed works;
 - 2) installation data with the required in-situ material properties and inspections;
 - 3) installation instructions with the necessary data for the handling, storing, setting, adjusting, connection and completion works (see 9.4, 9.5 and 9.6).
- (2) Table A.1 gives a summary of the information that should be included into the execution specification, as relevant, to be in accordance with this standard.

Table A.1 — List of information for inclusion in the execution specification, where relevant

Clause	Clause	Text
1 Scope	1 (2)	Specify all the specific requirements relevant for the particular structure
	1 (4)	If required, specify any additional requirements regarding lightweight concrete, other materials or special technology
	1 (5)	State any requirements on concrete members used as equipment for the execution
2 Normative references	2 (1)	Add all relevant national standards or provisions valid at the construction site
3 Definitions	3.17	Define the reference line for setting out
4 Execution management	4.1 (1)	All necessary technical information to be set out in the execution specification
	4.1 (3)	Specify requirements related to qualifications of personnel
	4.1 (4) and 4.2.1 (2)	National provisions which need to be respected
	4.2.1 (3)	Include procedure for altering execution specification
	4.2.1 (3)	Requirements for document distribution
	4.2.2 (1)	State if a quality plan is required
	4.2.4 (1)	State extent of special documentation if required
	4.3.1 (5)	Specify execution class and define who is responsible for the inspection
	4.3.1 (6)	Specify provisions related to inspection personnel
	4.3.1 (7)	If necessary, specify further requirements for the quality management regime
	4.3.2 (1) Table 1	Define inspections and acceptance testing of products without a CE marking or third party certification
	4.3.3 (1) Table 2 and Table 3	Check if the scopes of these inspections are adequate. If not give additional requirements
	4.4 (3)	If required specify rectification of possible non-conformances
5 Falsework and formwork	5.3 (1) and 5.4 (1)	If required specify if method statements shall be worked out
	5.3 (4)	Specify requirements to temporary support structures, if any
	5.4 (5)	Specify any requirements for surface finish
	5.4 (6)	Specify any requirements for special finishes or trial panels
	5.4 (7)	Specify any requirement for temporary support of the permanent structure
	5.5 (1)	Specify any requirements for special formwork
	5.6.2 (1)	Requirements for filling temporary holes etc.
	5.7 (1)	Requirements for removal of falsework and formwork to avoid deflections
5.7 (4)	If relevant, specify sequence of removal, where backpropping and/or re-propping of the structure is used	
6 Reinforcement	6.2 (1)	Specify types of reinforcement
	6.2 (3)	Specify permitted types of anchorages or couplers
	6.2 (6)	Requirement for reinforcement materials other than steel if used
	6.3 (1)	Provide cutting and bending schedules or identify that this is a task for the constructor
	6.3 (1)	Is bending at temperatures below $-5\text{ }^{\circ}\text{C}$ permitted and if so specify the precautions to be taken

Table A.1 (continued)

Clause	Clause	Text
	6.3 (1)	State if bending by heating is permitted
	6.3 (2)	Specify mandrel diameter for bending bars
	6.3 (3)	Specify mandrel diameter for welded reinforcement and fabric bent after welding
	6.3 (5)	Specify any requirements to straighten bent bars
	6.4 (1) and 6.4 (2)	Provisions for welding of reinforcement
	6.4 (3)	Specify if spot-welding is not permitted
	6.5 (1)	Specify the position of reinforcement including cover, the position of laps and joints etc.
	6.5 (2)	Specify if reinforcement by <i>running meters</i> is permitted
	6.5 (3)	Specify special requirements if any
	6.5 (4)	Specify nominal concrete cover, i.e. the required minimum cover + the numerical value of the permitted minus-deviation (ref. Clause 10 Figure 3b)
7 Prestressing	7.1 (2)	Requirements for installation of post-tensioning kits and qualification of personnel to perform the installation
	7.2.1 (1)	Requirements to the post-tensioning system
	7.2.3 (1)	Specify requirements for the prestressing steel
	7.2.3 (2)	State if alternatives to prestressing steel are permitted, and the requirements
	7.2.5 (2)	Description of tendon support
	7.4.1 (1)	Provisions for assembling of prestressing tendons
	7.4.1 (3)	Specify if welding of local anchorage zone reinforcement, anchor plates and spot welding of perforated plates is permitted
	7.5.1(3)	Identify stressing anchors and passive/dead end anchors
	7.5.1 (6)	Requirement relating to minimum compressive strength of concrete when application and/or transfer of prestressing force to the structure
	7.5.2 (1)	Actions to be taken when accuracy of elongation of pre-tensioning tendons cannot be achieved
	7.5.3 (1)	Actions to be taken when accuracy of elongation of post-tensioning tendons cannot be achieved
8 Concreting	8.1 (1)	Check that all the required concrete properties have been specified according to EN 206-1 and national standards or provisions valid in the place of use of the concrete
	8.1(3)	State the minimum upper sieve size, D, for the concrete
	8.2 (1)	State if a concreting plan is required
	8.2 (2)	State if a trial casting is required
	8.2 (4)	State requirements to construction joints where relevant
	8.2 (6)	State if an increased cover to the reinforcement is needed when casting directly on ground
	8.3 (4)	State if samples shall be taken
	8.3 (5)	State if contact with aluminium alloy is permitted e.g. aluminium
	8.4.4 (1)	If sprayed concrete is applied, the execution specification shall be according to EN 14487-2

Table A.1 (continued)

Clause	Clause	Text
	8.4.5 (2)	If slipforming is applied, the detailing and the equipment used shall be compatible
	8.4.6 (1)	Specify special requirements to underwater casting, methodology etc. if any
	8.4.6 (2)	If the concrete is to be cast under water, the detailing and the concreting method shall be compatible
	8.5 (2)	Specify if there are any need to protect the concrete in its early age from aggressive agents
	8.5 (7)	Specify the curing class to be applied
	8.5 (8)	Specify if there are any special curing requirements
	8.5 (16)	Specify if special measures to reduce the risk of thermal cracking are needed
	8.8 (1)	Specify possible surface finish requirements
9 Execution with precast concrete elements	9.1 (2)	Specify the precast concrete elements to be used
	9.4.1 (1) and 9.4.1 (3)	Specify special requirements to handling, storage, protection and position
	9.4.2 (3)	Specify requirements to product identification
	9.5.1 (1)	Requirements for placing and adjustments
	9.5.2 (4)	Input for the erection if relevant
	9.6	In situ works required for completion
	9.6.3 (1)	Detailing of structural connections
	9.6.3 (2)	Specify acceptable specific technologies
	9.6.3 (3)	Specify requirements to connections, inserts for joint connections and welded structural connections
10 Geometrical tolerances	10.1 (2)	Specify if tolerance class 2 applies (and where)
	10.1 (2) and 10.1 (4)	Specify any special tolerances and the elements to which they apply
	10.1 (3)	Specify if the tolerance requirements in Annex G do not apply
	10.1 (4) and 10.1 (5)	Specify if "box-principle" apply and with what tolerance, if different from ± 20 mm
	10.1 (6)	Specify requirements for surfaces with full contact bearing
	10.1 (7)	Specify tolerances for sections that are to be cast under water
	10.1 (10)	Possible requirements for the combination of construction tolerances and structural deflections
	10.2 (3)	State any requirements for the secondary lines

A.4.2.3 Execution record documentation

- (1) The following subjects should be considered for inclusion in the execution record documentation:
- a) sources of materials, material test reports and/or suppliers' declaration of conformity;
 - b) applications for variations and the responses;

- c) as-built drawings or sufficient information to enable as-built drawings to be produced for the entire structure including any precast elements;
- d) a description of non-conformities and where applicable, the corrective actions taken;
- e) a record of accepted changes to the project specification;
- f) records of any dimensional checks at hand-over;
- g) documentation of the inspections;
- h) events of significance for the properties of the finished structure;
- i) weather conditions during casting and curing.

Annex B (informative)

Guidance on Quality Management

Main clause numbers mirror those in Clause 4: Execution Management

B.4.3.1 Execution classes

- (1) Supervision and inspection are parts of the quality management.
- (2) The three execution classes give the option to specify the required level of quality management based on the importance of the component/structure and the criticality of the execution for its ability in fulfilling its function.

Execution class 1 should only be used for structures where consequences in case of failure are small or negligible.

- (3) The execution classes comprise requirements for inspection and, dependant on the relevant national annex or the execution specification, requirements for quality planning focusing on organisational measures and allocation of resources and personnel.

- (4) The three Execution Classes given in 4.3.1 are connected to the 3 levels of reliability differentiation given in EN 1990:2002, Annex B.

- (5) The extent of inspection to be applied shall be according to national regulations and shall be stated in the execution specification by the selection of the appropriate "Execution class".

B.4.3.2 Inspection of materials and products and

B.4.3.3 Inspection of execution

- (1) An inspection plan should, for each inspection point, state:
 - a) requirements;
 - b) references to the standard and the execution specification;
 - c) method of inspection, monitoring or testing;
 - d) definition of inspection section;
 - e) frequency of inspection, monitoring or testing;
 - f) acceptance criteria;
 - g) documentation;
 - h) responsible inspector;
 - i) possible involvement of other parties in the inspection.
- (2) An inspection plan may be prepared as a summary table with references to the inspection procedures and inspection instructions giving the details of inspection, monitoring and testing.
- (3) An inspection as described in this and the following paragraphs will normally satisfy the requirements of this standard with respect to the extent of inspection.

- a) Inspection in Execution class 1 is an inspection that might be carried out by the operator that performed the work. This implies an inspection to be carried out on all work done - self inspection.
 - b) For inspection in Execution class 2, there should, in addition to the self inspection, be an internal systematic and regular inspection with fixed routines within the company that performed the work - an internal systematic inspection.
 - c) For inspection in Execution class 3, there may be required, in addition to the self inspection and the internal systematic inspection performed by the constructor themselves, an extended inspection according to national regulations and/or the execution specification. This extended inspection may be performed by another company - an independent inspection
- (4) For structures in Execution class 3, the internal systematic inspection should include any concrete works of significance for the load-bearing capacity and durability of the structure. This includes inspection of formwork, reinforcement, cleaning before casting, concrete, concreting and curing, prestressing, injection etc.

In case extended (or independent) inspection is required, this should at least have an extent as that described for the internal systematic inspection in Execution class 2, see (5) below.

- (5) For structures in the Execution class 2, the internal systematic inspection should include an inspection of all concrete and reinforcement works for important structural members such as columns and beams. For other structural members inspection by spot checks should be carried out to an extent depending on the significance of the structural members for the load-bearing capacity and durability.
- (6) For structures of precast concrete elements all load-bearing supports and joints in the load-bearing system should be inspected.

Annex C (informative)

Guidance on falsework and formwork

Main clause numbers mirror those in Clause 5: Falsework and formwork

C.5.1 Basic Requirements

(1) The principal actions to be taken into account in the design are those set out in the Eurocodes principally EN 1990, *Eurocode – Basis of structural design*, and 1991-1-6, *Eurocode 1 – Actions on structures – General actions – Actions during execution*, including the governing combinations of:

- a) selfweight of formwork, reinforcement and concrete;
- b) pressure on formwork taking into account concrete type (including possible uplift);
- c) construction loads (crew, equipment, etc.), including static and dynamic effects of placing, compacting and construction traffic;
- d) wind and snow loads;
- e) particular actions at the place of execution such as provision for seismic actions.

NOTE Earthquake is normally not considered for temporary works like formwork and falsework.

(2) The provision of adequate bracing and its means of connection are important.

C.5.3 Design and Installation of falsework

(1) Wedges for the correct adjustment of falsework supports must be properly secured against slip during concreting.

(2) Differential settlements should be taken into account, for example when propping off the ground.

(3) Prevention of deleterious cracking in young concrete may be achieved by;

- a) limiting the deflection and/or settlement;
- b) controlling the casting sequence and/or concrete specification.

C.5.4 Design and Installation of formwork

(1) A closable window (opening) at the bottom of the form can be helpful when cleaning out the forms.

(2) Slipforming

- a) The form should have adequate batter to limit the form friction on the young concrete.
- b) A continuous guidance system between the reinforcement and the form should be used to ensure the required concrete cover within the tolerances given in Clause 10.

C.5.5 Special formwork

General

- (1) When proprietary formwork systems are used the manufacturer's requirements should be adhered to.
- (2) Permeable formwork lining can be used to improve the quality of the concrete in the cover zone and significantly reduces the number and size of blowholes.

C.5.6 Inserts in formwork and embedded components

General

- (1) When aluminium or galvanized steel inserts are to be used, special measures should be taken to avoid chemical reactions between the metal and the concrete.
- (2) Metallic materials of different electrical potential should not be electrically connected.

C.5.7 Removal of formwork and falsework

- (1) Where guidance on the required strength for removal of formwork and falsework is not given in the formwork or falsework design or the execution specification, then the following are suggested:
 - a) 5 MPa concrete strength to resist damage to surfaces that may arise during the striking;
 - b) backpropping or other support can be used to carry the actions imposed on the concrete member at that stage;
 - c) protection can be used to avoid surface damage due to weather until the concrete has achieved the design strength.

Annex D (informative)

Guidance on reinforcement

Main clause numbers mirror those in Clause 6: Reinforcement

D.6.2 Materials

(1) Reinforcing steel shall be specified in accordance with a national or European standard complying with EN 10080. Steel classes according to EN 1992-1-1:2004, Annex C, Table C.1, are not necessarily in accordance with such standards. The classes of EN 1992-1-1 refer to the ductility related parameters not strength, the execution specification should specify the characteristic yield strength required as well as the ductility parameters by reference to an applicable standard.

(2) In the selection of suitable chairs and spacers consideration of the loading during placing of the reinforcement and casting of the concrete should be taken into account. The chairs and spacers should not lead to enclosure of air, crack formation, penetration of water or damage the reinforcement over the design service life of the structure. Long continuous chairs that can be crack initiators are generally not suitable in a corrosive environment.

D.6.3 Bending, cutting, transport and storage of the reinforcement

(1) Measures should be taken to avoid:

- a) mechanical damage (e.g. notches or dents);
- b) rupture of welds;
- c) reduction of the section through corrosion.

(2) Minimum mandrel diameter is a Nationally Determined Parameters (NDPs) and their values for use in a country are given in the national annex to EN 1992-1-1. EN 10080 gives a minimum requirement for the bending test of reinforcement consistent with the recommended values in EN 1992-1-1. Steels with documented improved bending properties will allow smaller mandrel size. It is essential to ensure the consistency between the minimum mandrel size used and the bending properties of the actual reinforcement.

Unless otherwise specified the mandrel shall not be less than 4 times the bar diameter if the bar diameter is 16 mm or less, and 7 times the bar diameter if the bar diameter is larger than 16 mm. In case of rebending the mandrel should be twice this size, unless the rebend properties of the reinforcement are documented.

The actual bending diameter shall be as specified in the execution specification, taking account of the requirements of EN 1992-1-1 to avoid damage to the concrete in the bend eg. $\phi_{\text{actual}} \geq \phi_{\text{m,min}}$ where $\phi_{\text{m,min}}$ is per expression (8.1) of EN 1992-1-1.

The use of mandrels in the Renard series is recommended, diameter (in mm); 16, 20, 25, 32, 40, 50, 63, 80, 100, 125, 160, 200, 250, 320, 400, 500, 630.

(3) For welded reinforcement and fabric bent after welding, unless otherwise specified, when bending inside the heat affected zone (HAZ), the mandrel shall not be less than 5 times the bar diameter in case the welded bar is on the inside of the bend, if the weld is on the outside of the bend the mandrel diameter should be 20 times the bar diameter.

(4) The following conditions should be satisfied when cold bending reinforcing steel:

- a) the execution specification specifying shape and actual mandrel diameter;
- b) the execution specification will state if rebending at the same point is permitted;
- c) boxes used to cover reinforcing bars for later connection should be designed not to adversely affect the load bearing capacity of the concrete section or the corrosion protection of the reinforcement.

Annex E (informative)

Guidance on prestressing

Main clause numbers mirror those in Clause 7: Prestressing

E.7.3 Transport and storage

- (1) Prestressing steel, anchorages, couplers, and ready-made tendons should be transported on carriages, which are clean and free from chemical substances aggressive to the steel. Any contact with detrimental substances should be avoided by special packing in the mill or by supporting the steel in a way that prevents it from coming into contact with the carriage surfaces.
- (2) Transport by water should not be allowed without suitable protection.
- (3) The bar diameters that can be transported and stored as coils is to be approved.
- (4) Prestressing steel should not be stored in contact with the ground nor exposed to rain. Prestressing steel should preferably be stored in closed rooms at a relative humidity of less than 60 %.
- (5) Ready-made tendons within sheaths should be protected at their ends against the penetration of moisture, against condensation, and supported at distances, which does not impair the stability and tightness of the sheaths.
- (6) Corrosion of prestressing components should be avoided if possible. Light rusting on tensile elements is generally acceptable if it can be removed by a soft cloth. More significant rust can generally be accepted on the external surfaces of anchorage castings.

E.7.4 Installation of the tendons

- (1) Connections to anchorages and other connections should meet the same requirements as the sheaths.
- (2) Tapes for sealing of the sheaths should be free of chloride.
- (3) Prestressing steel should be cut with a disk cutter.

E.7.4.4 Post-tensioned tendons

- (1) Resistance against buckling of sheaths can be achieved by using a sufficiently stiff sheath or with temporary support from a polythene tube or similar.

E.7.5 Tensioning

E.7.5.1 General

- (1) Tensioning is a complex operation working with high forces on the jacks and the prestressing tendons. It is an operation which requires suitable safety measures and supervision by experienced personnel.

E.7.5.2 Pre-tensioned tendons

- (1) In addition to the requirements in 7.5.1 and 7.5.2, the tensioning programme should specify:
 - a) any special sequence of tensioning;

- b) the jack pressure and its equivalent jack force to be attained;
 - c) the minimum and maximum permissible tension in the tendons and their seating in the anchorages;
 - d) the required concrete strength at the time of releasing the prestressing force.
- (2) The operational suitability of reusable anchorage components should be proven by a check.

E.7.5.3 Post-tensioned tendons

- (1) In addition to the requirements in 7.5.1 and 7.5.3, the tensioning programme should specify:
- a) the prestressing system to be used;
 - b) the type and grade of prestressing steel;
 - c) the number of bars, wires or strands in each tendon;
 - d) the required concrete strength for the application of tension;
 - e) the order in which successive tendons have to be tensioned and any requirements for phased tensioning on a tendon;
 - f) the calculated tensioning and jacking force as well as the elongation of the tendons;
 - g) the anticipated seating at the anchorage;
 - h) any necessary partial or full release of the falsework.
- (2) The following should be recorded:
- a) the verification of the required concrete strength for the tensioning;
 - b) the type of prestressing jack used;
 - c) the measured jack force and the elongation of the tendon in each stage of tensioning;
 - d) the observed seating;
 - e) any severe deviation from the calculated tensioning force or elongation;
 - f) if specified, the release of falsework.

E.7.5.4 Internal and external unbonded tendons

- (1) Subclauses (1) and (2) of E.7.5.3 apply.

E.7.6 Protective measures

E.7.6.1 General

- (1) If the penetration of water or excessive humidity can be prevented, and if provisions valid at the construction site do not specify otherwise, the following construction periods are recommended:
- a) maximum of 12 weeks between fabrication of tendons and grouting;
 - b) maximum of 4 weeks in the formwork before casting of concrete;

- c) approximately 2 weeks in the tensioned condition before applying the protective measures in severe exposure conditions / environment. In benign exposure conditions / environment this period may be extended to 4 weeks.
- (4) If the period above between tensioning and grouting is exceeded, temporary protection should be maintained by an approved method. Application of approved water soluble oils or flushing of the ducts at appropriate intervals with dried air can provide suitable means of protection.

Annex F (informative)

Guidance on concreting

Main clause numbers mirror those in Clause 8: Concreting

F.8.1 Specification of concrete

EN 206-1 defines concrete as “ ... mixing cement, coarse and fine aggregate and water ...”.

EN 12620 defines coarse aggregates as aggregate with $D \geq 4$ mm where D is the actual upper sieve size of the aggregate. Included in this definition are both a maximum and a minimum percentage passing on D .

Concrete with aggregates of upper size as small as 4 mm might in some cases not support the design assumptions in EN 1992. A requirement for a larger upper sieve size D than 4 mm will therefore often be needed.

The D_{\max} defined in EN 206-1 as “maximum nominal upper aggregate size” corresponds to the definition in EN 1992-1-1 of d_g as “largest nominal maximum aggregate size”. d_g (D_{\max}) shall be selected to ensure a proper casting taking into account the cover and free spacing between the reinforcement bars.

The actual maximum size of the aggregate to be used must then be between the specified D and D_{\max} .

F.8.2 Pre-concreting operations

- (1) Construction joints should not be made at critical positions.
- (2) Structural elements should be isolated from the ground by a blinding layer of at least 50 mm unless the concrete cover to the reinforcement is increased according to the provisions of EN 1992-1-1.
- (3) Concreting onto frozen ground should not be permitted, unless special procedures are followed.
- (4) The surface temperature at the construction joint should be above 0 °C at the time of concreting.
- (5) The execution specification may define ambient temperatures above which precautions have to be planned to protect the concrete against damaging effects.

F.8.3 Delivery, reception and site transport of fresh concrete

- (1) The receiving inspection should be documented by signing the delivery ticket when relevant.
- (2) For SCC, receiving inspection should include testing of fresh state properties.

F.8.4.1 Placing and compaction – ordinary vibrated concrete

- (1) Compaction should be performed by internal or external vibration, unless otherwise agreed.
- (2) Concrete should be placed as near as practical to its final location. Vibration should be used to compact the concrete and not as a means of moving the concrete long distances.
- (3) Vibration by poker or surface vibrator should be applied systematically after placing until the expulsion of entrapped air has practically ceased. Excessive vibration, which might promote weak surface layers or segregation, should be avoided.
- (4) Normally the thickness of the concrete layer placed should be less than the length of the poker vibrator. Vibration should be systematic and include re-vibration of the top of the previous layer.

- (5) Where permanent formwork is incorporated in the structure, its energy absorption should be taken into account when deciding the method of compaction and consistency of the concrete.
- (6) In deep sections, re-compaction of the surface layer is recommended to prevent plastic settlement below horizontal top reinforcement.
- (7) Where only surface vibrators are used, the layer of concrete after compaction should, in normal situations, not exceed 100 mm unless proved acceptable by trial castings. Additional vibration near the supports may be required to obtain adequate compaction.
- (8) Surface finishing by screeding, trowelling or floating should be carried out in a manner and at the necessary time to achieve the specified surface finish.
- (9) Surface finishing should not result in laitance.
- (10) Water, cement, surface hardeners or other materials should not be added during the finishing operations unless specified or agreed.
- (11) When placing and compacting fresh concrete near prestressing tendons special care has to be taken in order not to damage or displace the tendons.

F.8.4.3 Placing and compaction – self compacting concrete

- (1) SCC mix design should comply with specific requirements in the fresh state depending on the type of application, and especially on:
 - a) confinement conditions related to the concrete element geometry and the quantity, type and location of reinforcement, inserts and recesses;
 - b) placing equipment (pump, truck-mixer, skip, etc);
 - c) placing methods (number of delivery points);
 - d) finishing method.

Those requirements might be expressed and justified in terms of:

- e) flowability and filling ability;
 - f) viscosity (measure of the speed of flow);
 - g) passing ability, (flow without blocking);
 - h) segregation stability.
- (2) The required consistence retention time depends on the transportation and placing time. This should be determined and specified.
 - (3) Self-compacting concrete should, as much as possible, be placed in one continuous pour so delivery rates should be matched to placing rate. The maximum allowed period of time between successive concrete layers should be known and not exceeded.
 - (4) Free-fall and horizontal flow of SCC should be limited in order to avoid any adverse effect on concrete quality and homogeneity.
 - (5) Vibration of SCC should generally be avoided as it is likely to result in significant segregation of the coarse aggregate. A carefully controlled and light vibration can be used if it is demonstrated that there is no adverse effect on concrete quality and homogeneity.

NOTE 1 At the time of publishing this standard, CEN has not completed its work to standardize test methods characterizing the properties of SCC nor additional provisions for its specification in EN 206-1. This work includes:

prEN 206-9 "Concrete – Part 9: Additional rules for self-compacting concrete (SCC)"

prEN 12350-8 "slump-flow test" characterizing the SCC's flowability and filling ability

prEN 12350-9 "V-funnel test" characterizing the SCC's viscosity

prEN 12350-10 "L-box test" characterizing the SCC's passing ability

prEN 12359-11 "Sieve segregation test" characterizing the SCC's segregation resistance

prEN 12350-12 "J-ring test" characterizing the SCC's passing ability

The constructor and the concrete producer might find additional guidance in national and European guidelines published by other bodies.

NOTE 2 Guidance regarding limitation of free-fall and horizontal flow can be found in published guidelines (e.g. RILEM SCC Technical Committee report).

F.8.5 Curing and protection

(1) The following methods are suitable for curing used separately or in sequence:

- a) keeping the formwork in place;
- b) covering the concrete surface with vapour-proof sheets which are secured at the edges and joints to prevent draughts;
- c) placing of wet coverings on the surface and protection of these coverings against drying out;
- d) keeping the concrete surface visibly wet with suitable water;
- e) application of a curing compound of established suitability.

Other curing methods of equal effectiveness may be used.

NOTE At the time of publishing this standard, CEN has not completed its work to standardize test methods characterizing the properties of curing compound, guidance can be found in CEN/TS 14754-1.

(2) The development of properties in the surface zone should be based on the relationship of compressive strength to maturity.

(3) Detailed estimates of the development of concrete properties may be based on one of the following methods:

- a) maturity calculation from temperature measurements taken at a maximum depth of 10 mm below the surface;
- b) maturity calculation based on the daily average air temperature;
- c) temperature-matched curing;
- d) rebound hammer testing (after calibration on relevant concrete test sample);
- e) other methods of established suitability.

(4) Maturity calculations should be based on an appropriate maturity function, proven for the type of cement or combination of cement and addition in use.

(5) Tables F.1 to F.3 give the duration of curing in number of days deemed to satisfy curing class 2 to curing class 4 respectively and should be used if no more accurate method is used for determining concrete strength in the cover zone.

Table F.1 — Minimum curing period for curing class 2 (corresponding to a surface concrete strength equal to 35 % of the specified characteristic strength)

Surface concrete temperature (<i>t</i>), °C	Minimum curing period, days ^a		
	Concrete strength development ^{c, d}		
	$(f_{cm2}/f_{cm28}) = r$		
	rapid $r \geq 0,50$	medium $0,50 > r \geq 0,30$	slow $0,30 > r \geq 0,15$
$t \geq 25$	1,0	1,5	2,5
$25 > t \geq 15$	1,0	2,5	5
$15 > t \geq 10$	1,5	4	8
$10 > t \geq 5^b$	2,0	5	11

^a Plus any period of set exceeding 5 h.

^b For temperatures below 5 °C, the duration should be extended for a period equal to the time below 5 °C.

^c The concrete strength development is the ratio of the mean compressive strength after 2 days to the mean compressive strength after 28 days determined from initial tests or based on known performance of concrete of comparable composition (see EN 206-1).

^d For very slow concrete strength development, special requirements should be given in the execution specification.

Table F.2 — Minimum curing period for curing class 3 (corresponding to a surface concrete strength equal to 50 % of the specified characteristic strength)

Surface concrete temperature (<i>t</i>), °C	Minimum curing period, days ^a		
	Concrete strength development ^{c, d}		
	$(f_{cm2}/f_{cm28}) = r$		
	rapid $r \geq 0,50$	medium $0,50 > r \geq 0,30$	slow $0,30 > r \geq 0,15$
$t \geq 25$	1,5	2,5	3,5
$25 > t \geq 15$	2,0	4	7
$15 > t \geq 10$	2,5	7	12
$10 > t \geq 5^b$	3,5	9	18

^a Plus any period of set exceeding 5 h.

^b For temperatures below 5 °C, the duration should be extended for a period equal to the time below 5 °C.

^c The concrete strength development is the ratio of the mean compressive strength after 2 days to the mean compressive strength after 28 days determined from initial tests or based on known performance of concrete of comparable composition (see EN 206-1).

^d For very slow concrete strength development, special requirements should be given in the execution specification.

Table F.3 — Minimum curing period for curing class 4 (corresponding to a surface concrete strength equal to 70 % of the specified characteristic strength)

Surface concrete temperature (t), °C	Minimum curing period, days ^a		
	Concrete strength development ^{c, d}		
	$(f_{cm2}/f_{cm28}) = r$		
	rapid $r \geq 0,50$	medium $0,50 > r \geq 0,30$	slow $0,30 > r \geq 0,15$
$t \geq 25$	3	5	6
$25 > t \geq 15$	5	9	12
$15 > t \geq 10$	7	13	21
$10 > t \geq 5$ ^b	9	18	30

^a Plus any period of set exceeding 5 h.
^b For temperatures below 5 °C, the duration should be extended for a period equal to the time below 5 °C.
^c The concrete strength development is the ratio of the mean compressive strength after 2 days to the mean compressive strength after 28 days determined from initial tests or based on known performance of concrete of comparable composition (see EN 206-1).
^d For very slow concrete strength development, special requirements should be given in the execution specification.

(6) The choice of curing classes is dependant on exposure classes, choice of concrete composition and choice of concrete cover to the reinforcement. Climatic conditions and size of elements are also important parameters.

(7) Curing compounds may penetrate the surface and make removal very difficult, therefore grit blasting or high pressure water jetting will normally be necessary if they have to be removed.

(8) The use of a curing compound containing a dye makes verification of application simple.

(9) Possible adverse effects of high concrete temperatures during curing include:

- a) delayed ettringite formation;
- b) significant reductions of strength;
- c) significant increase in porosity;
- d) increase in the temperature difference between the cast element and previously cast restraining elements.

F8.8 Surface finish

(1) The following requirements should be given as appropriate for each finish:

- a) The formwork face material: Acceptability of face material leaving an imprint on the concrete which is not specifically part of the finish. The constructor's freedom to use different face materials, to give greater re-use of the form face.
- b) Colour: No requirements for colour consistency or shade unless using special coloured materials.
- c) Blowholes: Limits on size, depth and frequency should be given where visual effects are important.

d) Abrupt and gradual irregularities: Size and frequency should be given. These irregularities are independent of any tolerance deviation allowed in the element and should encompass formwork face irregularities only.

e) Making Good: whether making good is permitted to improve the finish.

(2) A typical use of the finish types is given in Table F.4 to indicate the requirements for an execution specification.

Table F.4 — Types of surface finish

Type	Normal application	Examples
Formed surfaces		
Basic Finish:	Where no particular requirement is needed.	Foundations
Ordinary Finish:	Where not of visual importance or to receive applied finishes.	Areas with applied render finish or unseen surfaces such as inside ducts or lift shafts.
Plain Finish:	Where visual effect is of some importance.	Areas seen occasionally and areas which are prepared, direct painted areas where there are some particular requirements.
Special Finish:	Where special requirements have to be given	Areas where surface regularity and / or colour are important
Unformed surfaces		
Basic Finish:	A closed uniform surface produced by levelling. No further work is required.	Area to receive a screeded finish or other applied finishes.
Ordinary Finish:	A level uniform surface produced by floating or similar process.	Area for false floor and other applied floorings.
Plain Finish:	A dense smooth surface produced by trowelling or similar	Normal warehouses and factories, areas of plant rooms and work areas without other finish than paint.
Special Finish:	A surface where special requirements have to be given for further working of another finish.	Areas of warehouse floors for special trafficking.

Annex G (informative)

Guidance on geometrical tolerances

Main clause numbers mirror those in Clause 10: Geometrical tolerances

G.10.1 General

(1) In this annex, guidance is given for permitted geometrical deviations in terms of service performance placing compatibility. These are tolerances for geometrical quantities, which are considered to have small structural influence.

G.10.3 Base supports (foundations)

No	Type of deviation	Description	Permitted deviation Δ
			Tolerance Class 1
a	 <p>1 - support centre lines (horizontal section) y - secondary line in y - direction x - secondary line in x - direction</p>	Position in plan of a base support relative to the secondary lines	± 25 mm
b	 <p>1 - secondary level (vertical section) h - intended distance to base from secondary level</p>	Position in vertical direction of a base support relative to the secondary level	± 20 mm

Figure G.1 — Permitted deviations for the position of base supports (foundations)

G.10.4 Columns and walls

No	Type of deviation	Description	Permitted deviation Δ
Tolerance Class 1			
a	 <p>1 - column centre lines (horizontal section) y - secondary line in y - direction x - secondary line in x - direction</p>	Position in plane of a column relative to the secondary lines	± 25 mm
b	 <p>y - secondary line in y - direction</p>	Position in plane of a wall relative to the secondary line	± 25 mm
c		Free space between adjacent columns or walls	The larger of ^a ± 20 mm or ± $l/600$ But not larger than 60 mm
<p>a NOTE Stricter position tolerances may be required for columns and walls supporting precast elements depending on the length tolerance of the supported member and required support length.</p>			

Figure G.2 — Permitted deviations for position of columns and walls, horizontal sections

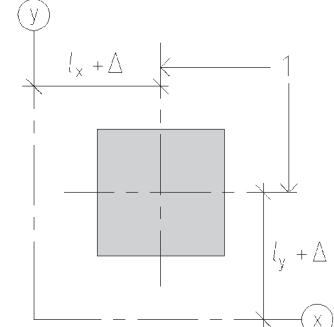
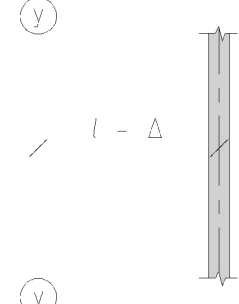
G.10.5 Beams and slabs

No	Type of deviation	Description	Permitted deviation Δ
			Tolerance Class 1
a		Horizontal straightness of beams	The larger of ± 20 mm or $\pm l/600$
b		Distance between adjacent beams, measured at corresponding points	The larger of ^a ± 20 mm or $\pm l/600$ but not more than 40 mm
a NOTE Stricter position tolerances may be required for beams supporting precast elements depending on the length tolerance of the supported member and required support length.			
c		Inclination of a beam or a slab	$\pm (10 + l/500)$ mm
d		Level of adjacent beams, measured at corresponding points	$\pm (10 + l/500)$ mm
e		Levels of adjacent floors at supports	± 20 mm

No	Type of deviation	Description	Permitted deviation Δ
f	 <p data-bbox="280 689 523 721">1 - secondary level</p>	<p data-bbox="995 405 1233 521">Level of upper floor measured relative to the secondary system</p> <p data-bbox="1054 555 1174 586">$H \leq 20$ m</p> <p data-bbox="1054 620 1174 651">20 m $<$ H</p>	<p data-bbox="1347 506 1406 537">± 20</p> <p data-bbox="1289 593 1461 624">$\pm 0,5 (H + 20)$</p> <p data-bbox="1265 689 1485 745">but not more than 50 mm</p>

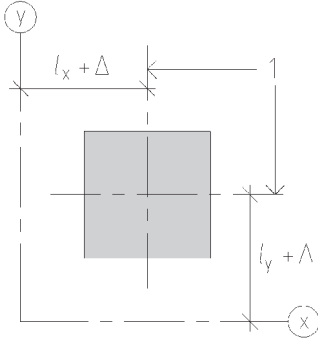
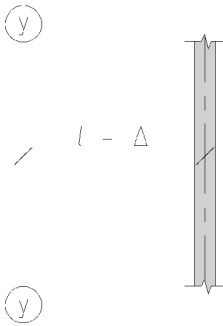
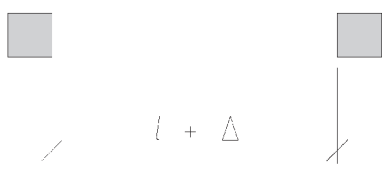
Figure G.3 — Permitted deviations for beams and slabs

G.10.6 Sections

No.	Type of deviation	Description	Permitted deviation Δ
			Tolerance Class 1
a	 <p data-bbox="309 1386 810 1417">a - length of cross-sectional dimension</p>	<p data-bbox="970 1146 1187 1202">Orthogonality of a cross-section</p>	<p data-bbox="1259 1146 1417 1202">The larger of $\pm 0,04 a$</p> <p data-bbox="1262 1240 1409 1272">or ± 10 mm,</p> <p data-bbox="1230 1301 1441 1357">but not more than ± 20 mm.</p>

Figure G.4 — Permitted cross-sectional deviations

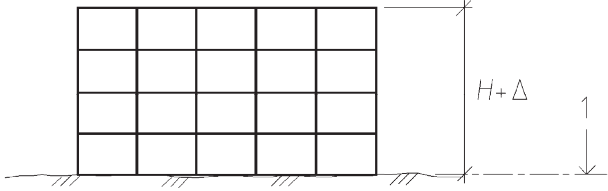
G.10.7 Tolerances for surfaces and edge straightness

No.	Type of deviation	Description	Permitted deviation Δ
			Tolerance Class 1
a	<p>Moulded or smoothed surface:</p> <p style="text-align: right;">global</p> <p style="text-align: right;">local</p> <p>Not moulded surface:</p> <p style="text-align: right;">global</p> <p style="text-align: right;">local</p> 	<p>Flatness</p> <p>$l = 2,0 \text{ m}$</p> <p>$l = 0,2 \text{ m}$</p> <p>$l = 2,0 \text{ m}$</p> <p>$l = 0,2 \text{ m}$</p>	<p>9 mm</p> <p>4 mm</p> <p>15 mm</p> <p>6 mm</p>
b		Skewness of cross-section	<p>The greater of</p> <p>$\pm a/25$ or $\pm b/25$,</p> <p>but not more than $\pm 30 \text{ mm}$.</p>
c		<p>Edge straightness</p> <p>For lengths:</p> <p>$l < \pm 1 \text{ m}$</p> <p>$l > 1 \text{ m}$</p>	<p>$\pm 8 \text{ mm}$</p> <p>$\pm 8 \text{ mm/m}$,</p> <p>but not more than $\pm 20 \text{ mm}$</p>

Figure G.5 — Permitted deviations for surfaces and edges

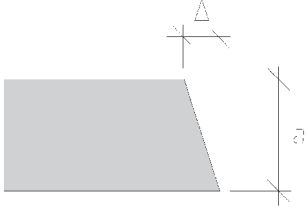
G.10.8 Tolerances for holes (round and rectangular) and inserts

No.	Type of deviation	Description	Permitted deviation Δ
Tolerance Class 1			
a	 <p>Δ_x and Δ_y - deviation from secondary line in x- and y-direction</p> <p>Δ_D - deviation on diameter</p>	<p>Holes and conduit inserts</p> <p>Δ_x and Δ_y</p> <p>Δ_D</p>	<p>± 25 mm</p> <p>± 10 mm</p> <p>Unless otherwise stated in the execution specification</p>
b	 <p>Δ_x and Δ_y - deviation from secondary line in x- and y-direction</p> <p>Δ_1 and Δ_2 - deviations on block-out</p> <p>Alternatively measured to centrelines as in fig a).</p>	<p>Blockout and recesses</p> <p>$\Delta_x, \Delta_y, \Delta_1, \Delta_2$</p>	<p>± 25 mm</p> <p>Unless otherwise stated in the execution specification</p>
c	 <p>l_1 - distance between bolt groups</p> <p>l_2 - distance between bolts within group</p> <p>l_3 - free length of bolt</p>	<p>Anchor bolts and similar inserts</p> <p>Placing of bolts and centre of a bolt group</p> <p>Internal distance between bolts in a group</p>	<p>$\Delta_1 = \pm 10$ mm</p> <p>$\Delta_2 = \pm 3$ mm</p>

		Protrusion	$\Delta_3 = + 25 \text{ mm};$ - 5 mm
		Inclination	$\Delta_s = \text{the greater of}$ 5 mm or $l_3/200$
			Unless otherwise stated in the execution specification
d	 <p>1 - nominal position in depth 2 - nominal position in plane</p>	Anchoring plates and similar inserts	$\Delta_x, \Delta_y = \pm 20 \text{ mm}$ $\Delta_z = \pm 10 \text{ mm}$ Unless otherwise stated in the execution specification

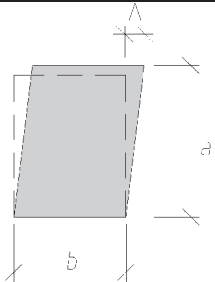
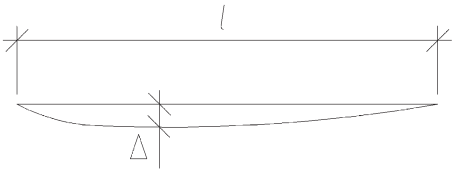
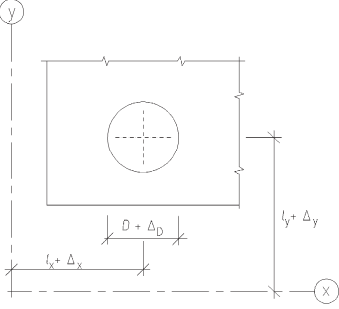
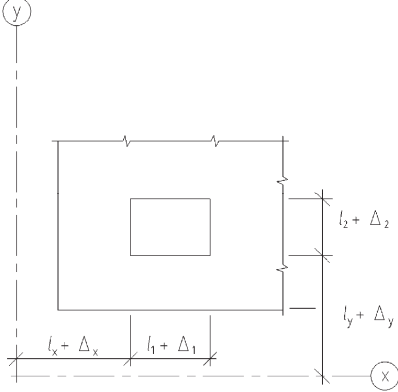
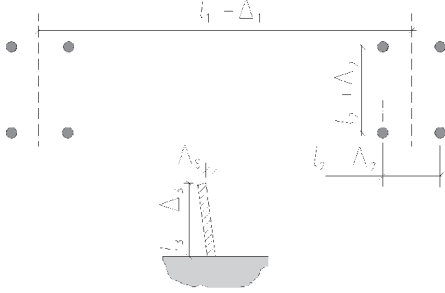
Figure G.6 — Permitted deviations for holes and inserts

Annex H (informative)

Guidance on National Annex

Guidance on a National Annex

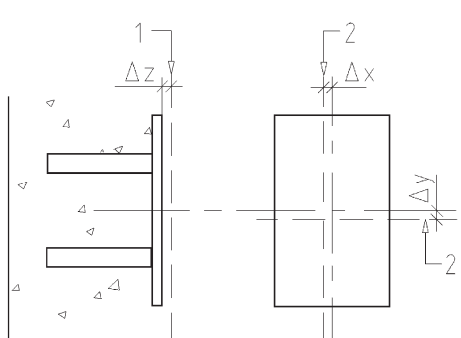
A number of clauses in this standard refer to requirements that should be given in the execution specification. These requirements may be project execution specific but in many situations such requirements can be given on a national basis either in national regulations or as national standards. It is foreseen that the use of a national annex to this standard can be helpful, either by referring to national requirements or alternatively by giving the national provisions directly for any items that are referred to as open for specification by the execution specification.

A national annex to this standard may include or give reference to national requirements on items such as the following:

- 1) Execution management; requirements to the organisation of construction works and the competence of the personnel performing the various tasks.
- 2) Project documentation; minimum requirements for documentation and records to be prepared and stored.
- 3) Quality management; requirements related to the use of Execution Classes and the extent and type of inspection required, see Table 3 and Annex B.
- 4) Reinforcement; give types of reinforcement consistent with the national application of EN 1992 and refer NDPs relevant to the execution of reinforcement.
- 5) Concreting; give requirements related to minimum D (upper sieve size of the aggregate), curing and selection of curing classes.
- 6) Surface finish; give reference to systems for surface finish descriptions.
- 7) Geometrical tolerances; give tolerance to minimum cover to reinforcement in accordance with EN 1992 and NDPs. Give values for tolerance class 2 where such values are not given, and for special structures (e.g. bridges, silos).

Bibliography

- [1] EN 1990, *Eurocode — Basis of structural design*
- [2] EN 1991 (all parts), *Eurocode 1: Actions on structures*
- [3] EN 1992 (all parts), *Eurocode 2: Design of concrete structures*
- [4] EN 1994 (all parts), *Eurocode 4: Design of composite steel and concrete structures*
- [5] EN 12620, *Aggregates for concrete*
- [6] EN 12812, *Falsework — Performance requirements and general design*
- [7] EN 12813, *Temporary works equipment — Load bearing towers of prefabricated components — Particular methods of structural design*
- [8] CWA 14646, *Requirements for the installation of post-tensioning kits for prestressing of structures and qualification of the specialist company and its personnel*
- [9] EN ISO 9000, *Quality management systems — Fundamentals and vocabulary (ISO 9000:2000)*
- [10] ISO 1803, *Building construction — Tolerances — Expression of dimensional accuracy — Principles and terminology*
- [11] ISO 4463-1, *Measurement methods for building — Setting-out and measurement — Part 1: Planning and organization, measuring procedures, acceptance criteria*
- [12] ISO 6934 (all parts), *Steel for the prestressing of concrete*
- [13] EN ISO 3766, *Construction drawings — Simplified representation of concrete reinforcement (ISO 3766:2003)*
- [14] EN 10139, *Cold rolled uncoated mild steel narrow strip for cold forming — Technical delivery conditions³⁾*

3) European Standard for prestressing steels (EN 10138) is presently in preparation. Until it is issued and implemented, national standards apply. In lieu of national standards, ISO 6934 may be applied.

National Annex (informative) to BS EN 13670

Execution Specification requirements

Introduction

This National Annex provides the UK requirements for information required by the Clauses in this Standard, listed in Table NA.1.

Scope

This National Annex gives:

- a) The UK requirements for the Execution Specification options described in the following subclauses of BS EN 13670:2009:

• 1 (2)	• 5.3 (4)	• 6.4 (1) & (2)	• 7.5.3 (1)	• 9.1 (2)
• 1 (4)	• 5.4 (5)	• 6.4 (3)	• 8.1 (1)	• 9.4.1 (1) & 9.4.1 (3)
• 1 (5)	• 5.4 (6)	• 6.5 (1)	• 8.1 (3)	• 9.4.2 (3)
• 2 (1)	• 5.4 (7)	• 6.5 (2)	• 8.2 (1)	• 9.5.1 (1)
• 3.17	• 5.5 (1)	• 6.5 (3)	• 8.2 (4)	• 9.5.2 (4)
• 4.1 (1)	• 5.6.2 (1)	• 6.5 (4)	• 8.2 (6)	• 9.6
• 4.1 (3)	• 5.7 (1)	• 7.1 (2)	• 8.3 (4)	• 9.6.3 (1)
• 4.1 (4) & 4.2.1 (2)	• 5.7 (4)	• 7.2.1 (1)	• 8.3 (5)	• 9.6.3 (2)
• 4.2.1 (3)	• 6.2 (1)	• 7.2.3 (1)	• 8.4.4 (1)	• 9.6.3 (3)
• 4.2.2 (1)	• 6.2 (3)	• 7.2.3 (2)	• 8.4.5 (2)	• 10.1 (2)
• 4.2.4 (1)	• 6.2 (6)	• 7.2.5 (2)	• 8.4.6 (1)	• 10.1 (2) & 10.1 (4)
• 4.3.1(5)	• 6.3 (1)	• 7.4.1 (1)	• 8.4.6 (2)	• 10.1 (3)
• 4.3.1 (7)	• 6.3 (1) b)	• 7.4.1 (3)	• 8.5 (2)	• 10.1(4) & 10.1 (5)
• 4.3.2 (1) Table 1	• 6.3 (1) c)	• 7.5.1 (3)	• 8.5 (7)	• 10.1 (6)
• 4.3.3 (1) Table 2 & 3	• 6.3 (2)	• 7.5.1 (6)	• 8.5 (8)	• 10.1 (7)
• 4.4 (3)	• 6.3 (3)	• 7.5.2 (1)	• 8.5 (16)	• 10.1 (10)
• 5.3 (1) & 5.4 (1)	• 6.3 (5)		• 8.8 (1)	• 10.2 (3)

- b) Decisions on the status of BS EN 13670:2009 informative annexes
c) References to non-contradictory complementary information.

NA.1 Nationally Determined Requirements

The UK requirements for the Execution specification options, as described in BS EN 13670:2009, are given in Table NA.1.

Table NA.1 UK requirement for Execution Specification requirements described in BS EN 13670:2009

Clause	Description	Option	UK requirement
1(2)	Scope: Special requirements	Specify all relevant specific requirements	Specify in Project Specification
1(4)	Scope: Special technologies	Specify requirement for special technologies	Specify in Project Specification
1 (5)	Scope: Use of concrete members	Specify requirement	Specify in Project Specification

	in execution		
2 (1)	Normative References: Relevant national standards or provisions	Add valid national standards or provisions	Add in Project Specification
3.17	Definition: Reference line location	Give defined position	Define position in project drawings
4.1 (1)	Execution Management: All necessary technical information	All necessary technical information	Specify in Project Specification
4.1 (3)	Execution Management: Skill of personnel	Specify requirement	Specify in Project Specification
4.1 (4) & 4.2.1(2)	Execution Management: National provisions to be respected	Specify provisions	Specify in Project Specification
4.2.1(3)	Execution Management: Altering Execution Specification	Specify procedure	Specify in Project Specification
4.2.1(3)	Execution Management: Document distribution	Specify requirement	Specify in Project Specification
4.2.2 (1)	Execution Management: Quality Plan requirement	Specify requirement	Quality Plan, as per the example specified in ISO 9000, is recommended, or use agreed alternative unless specified in Project Specification
4.2.4 (1)	Execution Management: Special documentation	Specify requirement	Specify in Project Specification
4.3.1 (5)	Execution Management: Execution Class	Specify class	Class 2 unless specified otherwise in Project Specification
4.3.1 (6)	Execution Management: Inspection personnel	Specify requirement	Specify in Project Specification
4.3.1 (7)	Execution Management: Additional quality management requirement	Specify requirement	Specify in Project Specification
4.3.2 (1) Table 1	Execution Management: Define inspection and acceptance testing	Specify requirement	Specify in Project Specification
4.3.3 (1) Table 2 & 3	Execution Management: Inspection scope – additional requirement	Specify requirement	Specify in Project Specification
4.4 (3)	Execution Management: Rectification of nonconformity	Specify procedures	All nonconformities to be rejected unless procedures for acceptance are given in Project Specification
5.3 (1) & 5.4 (1)	Falsework & Formwork: Method Statement	Specify requirement	Method Statement required unless specified otherwise in Project Specification
5.3 (4)	Falsework & Formwork: Temporary Support of permanent structure	Specify requirement	Specify in Project Specification
5.4 (5)	Falsework & Formwork: Surface finish	Specify requirement	Specify in Project Specification
5.4 (6)	Falsework & Formwork:	Specify requirement	Specify in Project Specification

	Special finish or trial panels		
5.4 (7)	Falsework & Formwork: Support of permanent structure	Specify requirement	Specify in Project Specification
5.5 (1)	Falsework & Formwork: Requirement for special formwork	Specify requirement	Specify in Project Specification
5.6.2 (1)	Falsework & Formwork: Temporary hole filling and finish	Specify requirement	Specify in Project Specification
5.7 (1)	Falsework & Formwork: Removal	Specify requirement	Specify in Project Specification
5.7 (4)	Falsework & Formwork: Sequence of removal	Specify requirement	Specify in Project Specification
6.2 (1)	Reinforcement: Type	Specify requirement	Specify in Project Specification
6.2 (3)	Reinforcement: Type of anchorage or couplers	Specify requirement	Specify in Project Specification
6.2 (6)	Reinforcement: Type other than steel	Specify requirement	Specify in Project Specification
6.3 (1)	Reinforcement: Bending and cutting schedules	Specify provider	Designer to provide unless specified otherwise in Project Specification
6.3 (1)	Reinforcement: Bending at temperatures below -5°C	Specify requirement	Not permitted unless specified otherwise in Project Specification
6.3 (1)	Reinforcement: Bending by heating	Specify requirement	Not permitted unless Specified otherwise in Project Specification
6.3 (2)	Reinforcement: Mandrel diameter for bending bars	Specify requirement	Mandrel size in accordance with BS EN 1992-1-1:2004, Table NA.6 a)
6.3 (3)	Reinforcement: Mandrel diameter for bending welded reinforcement and fabric after welding	Specify requirement	Mandrel size in accordance with BS EN 1992-1-1:2004, Table NA.6 b)
6.3 (5)	Reinforcement: Straightening of bent bars	Specify requirement	Specify in Project Specification
6.4 (1) & 6.4 (2)	Reinforcement: Welding reinforcement	Specify requirement	Not permitted unless specified otherwise in Project Specification
6.4 (3)	Reinforcement: Spot welding	Specify requirement	Permitted unless specified otherwise in Project Specification
6.5 (1)	Reinforcement: Position of reinforcement	Specify requirement	Give in drawings unless specified otherwise in Project Specification
6.5 (2)	Reinforcement: Running meters of reinforcement	Specify requirement	Give in drawings unless specified otherwise in Project Specification
6.5 (3)	Reinforcement: Special requirements	Specify requirement	Specify in Project Specification

6.5 (4)	Reinforcement: Nominal Concrete cover	Specify requirement	Give in drawings unless specified otherwise in Project Specification
7.1 (2)	Prestressing: Installation of post-tensioning kits and qualification of personnel	Specify requirement	Specify in Project Specification
7.2.1 (1)	Prestressing: Post-tensioning system	Specify requirement	Specify in Project Specification
7.2.3 (1)	Prestressing: Steel	Specify alternate National standard until EN 10138 is implemented	Prestressing steel to BS 5896 and BS 4486
7.2.3 (2)	Prestressing: Alternatives to prestressing steel	Specify requirement	Specify in Project Specification
7.2.5 (2)	Prestressing: Tendon support	Specify requirement	Specify in Project Specification
7.4.1 (1)	Prestressing: Assembling of prestress tendons	Specify requirement	Specify in Project Specification
7.4.1 (3)	Prestressing: Welding at local anchorages	Specify requirement	Specify in Project Specification
7.5.1 (3)	Prestressing: Stressing and end anchors	Identify position on drawings	Identify position on drawings
7.5.1 (6)	Prestressing: Concrete strength at transfer	Specify requirement	Specify in Project Specification
7.5.2 (1) & 7.5.3 (1)	Prestressing: Accuracy of elongation of tendons cannot be met	Specify action	Specify action in Project Specification
8.1 (1)	Concrete: Specification	Specify requirement	Specify in Project Specification using BS 8500
8.1 (3)	Concrete: Specification	Specify minimum upper sieve size D	8mm unless specified otherwise in Project Specification
8.2 (1)	Concrete: Concreting plan	Specify requirement	Required unless specified otherwise in Project Specification
8.2 (2)	Concrete: Trial casting	Specify requirement	Specify in Project Specification
8.2 (4)	Concrete: Construction joint preparation	Specify requirement	Specify in Project Specification
8.2 (6)	Concrete: Additional reinforcement cover	Specify requirement	Specify in Project Specification
8.3 (4)	Concrete: Taking of samples	Specify requirement	Take in accordance with BS 8500 unless specified otherwise in Project Specification
8.3 (5)	Concrete: Contact with aluminum	Specify requirement	No contact unless specified otherwise in Project Specification
8.4.4 (1)	Concrete: Sprayed concrete application	Specify using EN 14487 Part -1 and -2	Specify in Project Specification
8.4.5 (2)	Concrete: Slipforming	Specify compatible detail and equipment	Specify in Project Specification
8.4.6 (1)	Concrete: Underwater casting	Specify compatible detail and equipment	Specify in Project Specification
8.4.6 (2)	Concrete:	Specify compatible	Specified in Project Specification

	Underwater concreting	detail and methods	
8.5 (2)	Concrete: Protection from aggressive agents	Specify requirement	Specify in Project Specification
8.5 (7)	Concrete: Curing class	Specify requirement	Curing class 2 unless specified otherwise in Project Specification
8.5 (8)	Concrete: Special curing requirements	Specify requirement	Specify in Project Specification
8.5 (16)	Concrete: Early age cracking reduction	Specify requirement	Specify in Project Specification
8.8 (1)	Concrete: Surface finish	Specify requirement	Specify in Project Specification
9.1 (2)	Execution with precast elements: Elements	Specify requirement	Specify in Project Specification
9.4.1 (1) & 9.4.1 (3)	Execution with precast elements: Handling, storage, protection and position	Specify requirement	Specify in Project Specification
9.4.2 (3)	Execution with precast elements: Product identification	Specify requirement	Specify in Project Specification
9.5.1 (1)	Execution with precast elements: Placing and adjustment	Specify requirement	Specify in Project Specification
9.5.2 (4)	Execution with precast elements: Erection input	Specify requirement	Specify in Project Specification
9.6	Execution with precast elements: <i>In situ</i> works required for completion	Specify requirements	Specify in Project Specification
9.6.3 (1)	Execution with precast elements: Connections	Specify requirements	In accordance with manufacturer's instruction unless specified otherwise in Project Specification
9.6.3 (2)	Execution with precast elements: Special connection technologies	Specify acceptable technologies	Specify in Project Specification
9.6.3 (3)	Execution with precast elements: Connections	Specify requirements	Specify in Project Specification
10.1 (2)	Geometric Tolerances: Tolerance class 2	Specify where class 2 applies	Class 1 applies unless specified otherwise in Project Specification
10.1 (2) & 10.1 (4)	Geometric Tolerances: Special tolerances and location	Specify requirements	Specify in Project Specification
10.1 (3)	Geometric Tolerances: Tolerances in Annex G	Specify if tolerances in Annex G do not apply	Tolerances in Annex G apply unless specified otherwise in Project Specification
10.1 (4) & 10.1 (5)	Geometric Tolerances: "Box principle"	Specify application	Not to apply unless specified otherwise in Project Specification
10.1 (6)	Geometric Tolerances: Surfaces with full contact bearing	Specify requirements	Specify in Project Specification
10.1 (7)	Geometric Tolerances: Sections cast under water	Specify requirements	Specify in Project Specification
10.1 (10)	Geometric Tolerances: Combination of	Specify requirements	Specify in Project Specification

	construction tolerances and structural deflections		
10.2 (3)	Geometric Tolerances: Secondary lines	Specify requirements	Specify in Project Specification

NA.2 Decisions on the status of informative annexes in BS EN 13670:2009

Annex NA: This National Annex sets out UK requirements for information to be specified.

Annex B to F inclusive: Informative status.

Annex G: Should be used for all works unless specified otherwise in Project Specification.

Annex H: Guidance adopted in this National Annex.

NA.3 References to non-contradictory complementary information

The specification requirements for types of concrete structures, such as buildings or bridges, will require particular requirements in a Project Specification or, for simplification, the adoption of a National Specification for a type of concrete structure.

NSCS Ed 4 is such a document that deal with building structures and is considered to contain Non-contradictory complementary information.

Bibliography

Standards publications

BS 5896, *Specification for high tensile steel wire and strand for the prestressing of concrete*

BS 4486, *Specification for hot rolled and hot rolled and processed high tensile alloy steel bars for the prestressing of concrete*

BS 8500-1, *Concrete. Complementary British Standard to BS EN 206-1. Method of specifying and guidance for the specifier*

BS 8500-2, *Concrete. Complementary British Standard to BS EN 206-1. Specification for constituent materials and concrete*

BS EN 1992-1-1:2004, *Eurocode 2: Design of concrete structures. General rules and rules for buildings*

BS EN 13670:2009, *Execution of concrete structures*

Other publications

ISO 9000, *Quality management systems. Fundamentals and vocabulary*

BSI - British Standards Institution

BSI is the independent national body responsible for preparing British Standards. It presents the UK view on standards in Europe and at the international level. It is incorporated by Royal Charter.

Revisions

British Standards are updated by amendment or revision. Users of British Standards should make sure that they possess the latest amendments or editions.

It is the constant aim of BSI to improve the quality of our products and services. We would be grateful if anyone finding an inaccuracy or ambiguity while using this British Standard would inform the Secretary of the technical committee responsible, the identity of which can be found on the inside front cover. Tel: +44 (0)20 8996 9000. Fax: +44 (0)20 8996 7400.

BSI offers members an individual updating service called PLUS which ensures that subscribers automatically receive the latest editions of standards.

Buying standards

Orders for all BSI, international and foreign standards publications should be addressed to Customer Services. Tel: +44 (0)20 8996 9001. Fax: +44 (0)20 8996 7001 Email: orders@bsigroup.com You may also buy directly using a debit/credit card from the BSI Shop on the Website <http://www.bsigroup.com/shop>

In response to orders for international standards, it is BSI policy to supply the BSI implementation of those that have been published as British Standards, unless otherwise requested.

Information on standards

BSI provides a wide range of information on national, European and international standards through its Library and its Technical Help to Exporters Service. Various BSI electronic information services are also available which give details on all its products and services. Contact Information Centre. Tel: +44 (0)20 8996 7111 Fax: +44 (0)20 8996 7048 Email: info@bsigroup.com

Subscribing members of BSI are kept up to date with standards developments and receive substantial discounts on the purchase price of standards. For details of these and other benefits contact Membership Administration. Tel: +44 (0)20 8996 7002 Fax: +44 (0)20 8996 7001 Email: membership@bsigroup.com

Information regarding online access to British Standards via British Standards Online can be found at <http://www.bsigroup.com/BSOL>

Further information about BSI is available on the BSI website at <http://www.bsigroup.com>.

Copyright

Copyright subsists in all BSI publications. BSI also holds the copyright, in the UK, of the publications of the international standardization bodies. Except as permitted under the Copyright, Designs and Patents Act 1988 no extract may be reproduced, stored in a retrieval system or transmitted in any form or by any means – electronic, photocopying, recording or otherwise – without prior written permission from BSI.

This does not preclude the free use, in the course of implementing the standard, of necessary details such as symbols, and size, type or grade designations. If these details are to be used for any other purpose than implementation then the prior written permission of BSI must be obtained.

Details and advice can be obtained from the Copyright and Licensing Manager. Tel: +44 (0)20 8996 7070 Email: copyright@bsigroup.com