

Plastics piping systems for renovation of underground non-pressure drainage and sewerage networks —

Part 7: Lining with spirally-wound pipes

The European Standard EN 13566-7:2007 has the status of a
British Standard

ICS 93.030

National foreword

This British Standard was published by BSI. It is the UK implementation of EN 13566-7:2007.

The UK participation in its preparation was entrusted by Technical Committee PRI/88, Plastics piping systems, to Subcommittee PRI/88/3, Rehabilitation of pipeline systems using plastics piping materials and components.

A list of organizations represented on this committee can be obtained on request to its secretary.

This publication does not purport to include all the necessary provisions of a contract. Users are responsible for its correct application.

Compliance with a British Standard cannot confer immunity from legal obligations.

This British Standard was published under the authority of the Standards Policy and Strategy Committee on 30 April 2007

Amendments issued since publication

Amd. No.	Date	Comments

© BSI 2007

ISBN 978 0 580 50586 7

ICS 93.030

English Version

Plastics piping systems for renovation of underground non-pressure drainage and sewerage networks - Part 7: Lining with spirally-wound pipes

Systèmes de canalisations plastiques pour la rénovation des réseaux d'assainissement enterrés sans pression - Partie 7 : Tubage par enroulement hélicoïdal avec espace annulaire

Kunststoff-Rohrleitungssysteme für die Renovierung von erdverlegten drucklosen Entwässerungsnetzen (Freispiegelleitungen) - Teil 7: Wickelrohr-Lining

This European Standard was approved by CEN on 3 February 2007.

CEN members are bound to comply with the CEN/CENELEC Internal Regulations which stipulate the conditions for giving this European Standard the status of a national standard without any alteration. Up-to-date lists and bibliographical references concerning such national standards may be obtained on application to the CEN Management Centre or to any CEN member.

This European Standard exists in three official versions (English, French, German). A version in any other language made by translation under the responsibility of a CEN member into its own language and notified to the CEN Management Centre has the same status as the official versions.

CEN members are the national standards bodies of Austria, Belgium, Bulgaria, Cyprus, Czech Republic, Denmark, Estonia, Finland, France, Germany, Greece, Hungary, Iceland, Ireland, Italy, Latvia, Lithuania, Luxembourg, Malta, Netherlands, Norway, Poland, Portugal, Romania, Slovakia, Slovenia, Spain, Sweden, Switzerland and United Kingdom.



EUROPEAN COMMITTEE FOR STANDARDIZATION
COMITÉ EUROPÉEN DE NORMALISATION
EUROPÄISCHES KOMITEE FÜR NORMUNG

Management Centre: rue de Stassart, 36 B-1050 Brussels

Contents	Page
Foreword	4
Introduction	6
1 Scope	7
2 Normative references	7
3 Terms and definitions, symbols and abbreviations	8
3.1 Terms and definitions.....	8
3.2 Symbols and abbreviations.....	8
3.2.1 Symbols	8
3.2.2 Abbreviations	8
4 Pipes at the “M” stage — Requirements for profiled plastics strips	9
4.1 Materials.....	9
4.2 General characteristics	9
4.3 Material characteristics	9
4.4 Geometric characteristics	10
4.5 Mechanical characteristics.....	11
4.6 Physical characteristics.....	11
4.7 Jointing.....	11
4.8 Marking	11
5 Fittings at the “M” stage	11
6 Ancillary components	12
7 Fitness for purpose of the lining system at the “I” stage	12
7.1 Materials.....	12
7.2 General characteristics	12
7.3 Material characteristics	12
7.4 Geometric characteristics	12
7.5 Mechanical characteristics.....	12
7.6 Physical characteristics.....	13
7.7 Additional characteristics	13
8 Installation practice	13
8.1 Preparatory work.....	13
8.2 Storage, handling and transportation of profiled plastics strips and fittings	13
8.3 Equipment.....	13
8.4 Installation	13
8.5 Process-related inspection and testing.....	14
8.6 Lining termination.....	14
8.7 Reconnecting to existing manholes and laterals	14
8.8 Final inspection and testing	14
8.9 Documentation.....	14
Annex A (informative) Recommended scheme for assessment of conformity	15
A.1 Scope	15
A.2 General	15
A.3 Testing and inspection	15
A.3.1 Material specification PVC	15
A.3.2 Grouping	16
A.3.3 Type testing (TT).....	16

A.3.4	Batch release tests (BRT).....	17
A.3.5	Process verification testing.....	17
A.3.6	Audit testing tests (AT)	18
A.3.7	Indirect testing (IT).....	18
A.3.8	Inspection and test records.....	18
Annex B (normative) Test method for watertightness of SWO pipes whilst subjected to bending.....		19
B.1	Scope.....	19
B.2	Principle	19
B.3	Apparatus	19
B.4	Test piece	20
B.5	Test temperature	20
B.6	Test procedure.....	20
B.7	Requirements	21
B.8	Test Report.....	21
Bibliography.....		22

Foreword

This document (EN 13566-7:2007) has been prepared by Technical Committee CEN/TC 155 "Plastics piping systems and ducting systems", the secretariat of which is held by NEN.

This European Standard shall be given the status of a national standard, either by publication of an identical text or by endorsement, at the latest by September 2007, and conflicting national standards shall be withdrawn at the latest by March 2009.

System standards for renovation dealing with the following applications are either available or in preparation:

- **Plastics piping systems for renovation of underground non-pressure drainage and sewerage networks (this application);**
- Plastics piping systems for renovation of underground water supply networks;
- Plastics piping systems for renovation of underground gas supply networks;
- Plastics piping systems for renovation of underground drainage and sewerage networks under pressure;
- Plastics piping systems for renovation of industrial pipelines.

These system standards are distinguished from systems standards for conventionally installed plastics piping systems by setting requirements for certain characteristics in the as installed condition, after site processing. This is in addition to requirements for characteristics of plastics piping systems as manufactured.

These system standards are complemented by the information contained in ISO Technical Report 11295 [1] and supporting standard EN 13689 [2] listed in the Bibliography.

The system standard EN 13566 comprises six parts, as follows:

- *Part 1: General*
- *Part 2: Lining with continuous pipes*
- *Part 3: Lining with close-fit pipes*
- *Part 4: Lining with cured-in-place pipes*
- *Part 5: Lining with discrete pipes (possible future work)*
- *Part 7: Lining with spirally-wound pipes (the present standard)*

A consistent structure of clause headings has been adopted for all parts to facilitate direct comparisons across renovation families.

Figure 1 shows the common part and clause structure and the relationship between this standard and the system standards for other applications.

According to the CEN/CENELEC Internal Regulations, the national standards organizations of the following countries are bound to implement this European Standard: Austria, Belgium, Bulgaria, Cyprus, Czech Republic, Denmark, Estonia, Finland, France, Germany, Greece, Hungary, Iceland, Ireland, Italy, Latvia, Lithuania, Luxembourg, Malta, Netherlands, Norway, Poland, Portugal, Romania, Slovakia, Slovenia, Spain, Sweden, Switzerland and United Kingdom.

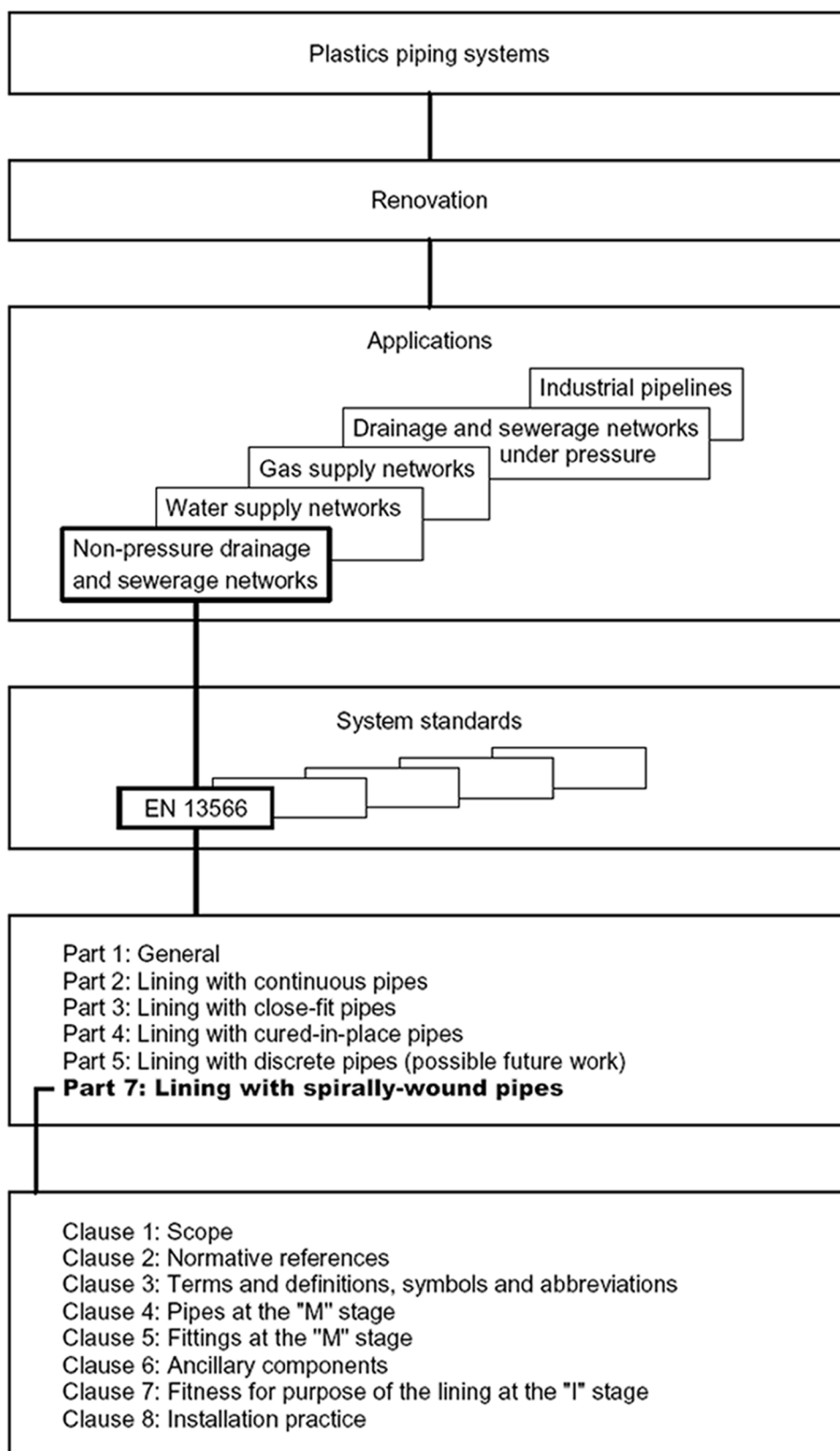

Figure 1 — Format of the renovation system standards

Introduction

The requirements for any given renovation technique family are covered by *Part 1: General*, used in conjunction with the relevant other part. For example, for the requirements relating to *Lining with spirally-wound pipes* it is necessary to refer to both part 1 and part 7. Complementary information is contained in ISO/TR 11295 [1] and EN 13689 [2], listed in the bibliography.

1 Scope

This part of EN 13566, read in conjunction with EN 13566-1, specifies requirements and test methods for pipes that are formed on site by spirally winding and jointing a pre-manufactured profiled plastics strip using a dedicated winding machine in front of the open end of an existing pipeline (e.g. in a manhole). The pipes thus formed are simultaneously inserted into the existing pipeline by the winding forces.

It covers spirally-wound pipes of a fixed diameter made of profiled plastics strips of unplasticized poly(vinyl chloride) (PVC-U) with an integral locking mechanism. These spirally-wound pipes are used for renovating non-pressure drainage and sewerage networks and are fixed in place by grouting the annular space.

NOTE The grouting procedure is outside the scope of this standard.

2 Normative references

The following referenced documents are indispensable for the application of this document. For dated references, only the edition cited applies. For undated references, the latest edition of the referenced document (including any amendments) applies.

EN 1979, *Plastics piping and ducting systems — Thermoplastics spirally-formed structured-wall pipes — Determination of the tensile strength of a seam*

EN 13566-1:2002, *Plastics piping systems for renovation of underground non-pressure drainage and sewerage networks — Part 1: General*

EN 13566-4:2002, *Plastic piping systems for renovation of underground non-pressure drainage and sewerage networks — Part 4: Lining with cured-in-place pipes*

EN ISO 179-2, *Plastics — Determination of Charpy impact properties — Part 2: Instrumented impact test (ISO 179-2:1997)*

EN ISO 306, *Plastics - Thermoplastic materials - Determination of Vicat softening temperature (VST) (ISO 306:2004)*

EN ISO 527-1, *Plastics - Determination of tensile properties - Part 1: General principles (ISO 527-1:1993 including Corr 1:1994)*

EN ISO 527-2, *Plastics — Determination of tensile properties — Part 2: Test conditions for moulding and extrusion plastics (ISO 527-2:1993 including Corr 1:1994)*

EN ISO 9967, *Plastics pipes — Determination of creep ratio (ISO 9967:1994)*

EN ISO 9969, *Thermoplastics pipes – Determination of ring stiffness (ISO 9969:1994)*

ISO 37, *Rubber, vulcanized or thermoplastic — Determination of tensile stress-strain properties*

ISO 7619-1, *Rubber, vulcanized or thermoplastic — Determination of indentation hardness — Part 1: Durometer method (Shore hardness)*

3 Terms and definitions, symbols and abbreviations

3.1 Terms and definitions

For the purposes of this document, the terms and definitions given in EN 13566-1:2002 and the following apply.

3.1.1

spirally-wound pipe

pipe formed by continuously winding and joining a profiled strip

3.1.2

seam

joint between adjacent profiled plastics strips formed by an integral locking mechanism and seam sealant

3.1.3

integral locking mechanism

mechanical interlock achieved by suitable design of the edges of the extruded profile

3.1.4

seam sealant

thermoplastic or adhesive material added to the integral locking mechanism to make the seam leaktight

3.2 Symbols and abbreviations

The symbols and abbreviations given in EN 13566-1:2002 and the following apply.

3.2.1 Symbols

A_w cross sectional area of the strip [mm^2/mm]

d_e external diameter [mm]

e_a neutral axis of the strip [mm]

e_o overall profile height [mm]

$e_{w,\text{min}}$ minimum waterway wall thickness [mm]

e_w waterway wall thickness at any point [mm]

I_w second moment of area of the strip [mm^4/mm]

l_s length of the test piece for short term tensile force resistance test of the locked seam [mm]

S ring stiffness of the pipe [kN/m^2]

w effective width of the strip [mm]

w_s width of the test piece for short term tensile force resistance test of the locked seam [mm]

3.2.2 Abbreviations

EPDM ethylene-propylene-diene monomer

PE-C	chlorinated polyethylene
PVC-U	unplasticized poly(vinyl chloride)
SWO	spirally-wound

4 Pipes at the “M” stage — Requirements for profiled plastics strips

NOTE This clause details the requirements for profiled plastics strips only.

4.1 Materials

The material of the profiled plastics strip shall be unplasticized poly(vinyl chloride) (PVC-U), to which are added those additives needed to facilitate the manufacture and/or installation of pipes conforming to this standard.

Depending on the design of the integral locking mechanism, the seam sealant shall comprise one or more of the following materials:

- elastomers (PE-C, EPDM, silicone);
- adhesives (amorphous poly-alpha-olefins) conforming to DIN 16970:1970 [3];

Only virgin and own reprocessable materials, as defined in EN 13566-1, are permitted for the profiled plastics strips and seam sealant. The material(s) used for the seam sealant shall be declared.

4.2 General characteristics

When viewed without magnification the surfaces of the profiled plastics strips shall be smooth, clean and free from scoring, cavities and other defects that may affect their performance.

4.3 Material characteristics

The material of the profiled plastics strip when extruded to a flat plate of thickness of 3 mm to 6 mm shall conform to the requirements given in Table 1.

Seam sealant materials shall conform to the requirements given in Table 2.

Table 1 — Material characteristics strips of PVC-U for profiled plastics

Characteristics	Requirements	Test parameters		Test method
		Parameter	Value	
<i>E</i> -Modulus (tensile)	≥ 2 000 MPa	Speed of testing Specimen	1 mm/min Type 1 B	EN ISO 527-2
Tensile strength Longitudinal	≥ 35 MPa	Speed of testing Specimen	5 mm/min Type 1 B	EN ISO 527-1
Elongation at break	≥ 40 %			
Charpy impact strength	≥ 10 kJ/m ²	Pendulum Specimen	1 J 1 FC, DV notch	EN ISO 179-2

Table 2 — Material characteristics of seam sealant

Characteristics	Requirements	Test Parameter		Test Method
		Parameter	Value	
PE-C				
Tensile strength Longitudinal	≥ 5 MPa	Speed of testing Specimen	5 mm/min Type 1B	EN ISO 527-1
Elongation at break	≥ 200 %			
Shore hardness A	60 ± 5	Shall conform to ISO 7619-1		ISO 7619-1
EPDM, silicone				
Tensile strength Longitudinal	≥ 1 MPa	Speed of testing Specimen	200 mm/min Type 1B	ISO 37
Elongation at break	≥ 200 %			
Shore hardness A	30 ± 5	Shall conform to ISO 7619-1		ISO 7619-1

4.4 Geometric characteristics

The dimensions and section properties, including tolerances of the profiled plastics strips and of the lock-seal mechanism, shall be declared by the profile plastics strips supplier.

The declared values shall conform to the requirements given in Table 3, where applicable.

Table 3 — Profile plastics strip dimensions and section properties

Characteristics	Symbol	Units	Requirements
Overall profile height	e_o	mm	Declared value but not less than 4,5 mm
	e_w	mm	Declared value but not less than 1,4 mm
	e_a	mm	Declared value
	W	mm	Declared value
	A_W	mm ² /mm	Declared value
	I_w	mm ⁴ /mm	Declared value
Minimum pipe diameter	$d_{e,min}$	mm	Declared value ^a
Maximum pipe diameter	$d_{e,max}$	mm	Declared value ^b
^a $d_{e,min}$ shall be limited by the maximum allowable winding strain in the profile strip. ^b $d_{e,max}$ shall be limited by the minimum pipe ring stiffness requirement specified in EN 13566-1:2002, 7.5.			

The profile plastics strip supplier shall assign to each profile strip a unique product code (see 4.8) from which the dimensions and section properties listed in Table 3 shall be declared.

An example of a profiled plastics strip excluding the seam is illustrated in Figure 2.

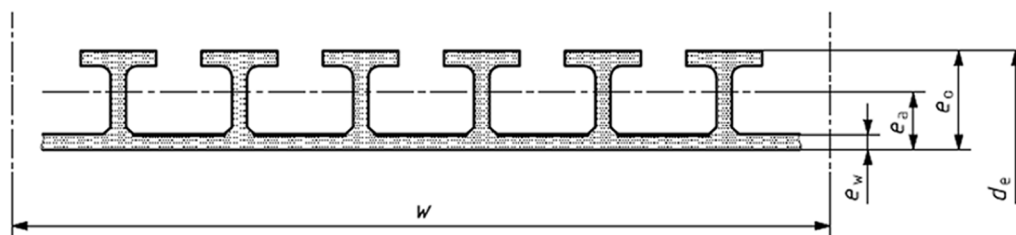

Figure 2 — Example of a cross-section of a profiled plastics strip

The overall profile height e_o and the waterway wall thickness e_w (see Figure 2) shall be measured with a micrometer accurate to within 0,1 mm, or by an equivalent method. The average of 4 measurements, each of e_o and e_w along 1 m of the profiled plastics strips shall be greater than their respective declared values.

The measured values shall conform to the declared values and tolerances.

4.5 Mechanical characteristics

No requirements at the “M” stage.

NOTE Because all mechanical characteristics of the profiled strip are measured after spirally winding into a pipe the related requirements and test methods are given in 7.5.

4.6 Physical characteristics

The Vicat softening temperature of the profiled plastics strips material shall conform to the requirements given in Table 4, when tested in accordance with Table 4.

Table 4 — The Vicat softening temperature of profiled plastics strips

Characteristic	Requirement	Test parameters		Test method
		Parameter	Value	
Vicat B 50	≥ 75 °C	Test piece thickness	3 mm minimum	EN ISO 306

4.7 Jointing

Profiled plastics strips shall be manufactured in such lengths that no jointing is required between points of access to the sewer.

4.8 Marking

Marking shall conform to EN 13566-1:2002, 4.8.

The requirements of items b) and c) of EN 13566-1:2002, 4.8 shall be covered by marking the profiled plastics strip code specified in 4.4.

5 Fittings at the “M” stage

Cured-in-place lateral connection collars shall conform to EN 13566-4:2002, Clause 5.

6 Ancillary components

This European standard does not give requirements and test methods for any ancillary component.

7 Fitness for purpose of the lining system at the “I” stage

7.1 Materials

The spirally-wound pipe and any fittings may consist of different material components selected from the ranges defined in 4.1 and Clause 5.

7.2 General characteristics

The general characteristics shall conform to EN 13566-1.

7.3 Material characteristics

The material characteristics shall conform to 4.3.

7.4 Geometric characteristics

The external diameter d_e of the SWO pipe shall be within the range of diameter ($d_{e,min}$ to $d_{e,max}$), which shall be declared by the profiled plastics strip supplier within the capability range of the dedicated winding machine.

7.5 Mechanical characteristics

Ring stiffness and creep ratio values of the largest and smallest diameter SWO pipes which can be wound from each profiled plastics strip by the dedicated winding machine, shall be declared by the profiled plastics strip supplier.

When tested in accordance with the methods given in Table 5, as applicable, SWO pipes, taken from actual or simulated installation in accordance with 7.7 shall have mechanical characteristics conforming to Table 5.

NOTE 1 Due to the influence of winding stresses, ring stiffness values cannot be predicted by calculation from the l_w value and E-modulus of the profiled plastics strip.

NOTE 2 The creep ratio value required in Table 5 is a 2 year value.

Table 5 — Mechanical characteristics of SWO pipes as installed

Characteristics	Requirements	Test parameters		Test method
		Parameters	Value	
Ring stiffness	Declared value, but not less than the minimum specified in EN 13566-1	Test temperature Deflection Deflection speed: 200 mm ≤ d_e < 400 mm 400 mm ≤ d_e < 700 mm d_e ≥ 700 mm	(23 ± 2) °C 3 % (10 ± 2) mm/min (20 ± 2) mm/min (50 ± 5) mm/min	EN ISO 9969
Creep ratio	Declared value, but not greater than 3,5	Shall conform to EN ISO 9967		
Tensile strength of a locked seam	Declared value, but not less than 4 N/mm	Test piece width Distance between grips Speed of testing	(15 ± 0,5) mm Both grips at (10 ± 1) mm of the seam border 5 mm/min	EN 1979

7.6 Physical characteristics

The physical characteristics shall conform to 4.6.

7.7 Additional characteristics

Samples of SWO pipes wound to the minimum external diameters d_e declared by the profiled plastics strip supplier (see 4.4) shall be watertight when tested in accordance with Annex B.

8 Installation practice

8.1 Preparatory work

Preparatory work shall conform to EN 13566-1.

8.2 Storage, handling and transportation of profiled plastics strips and fittings

Storage, handling and transportation of profiled plastics strips and fittings shall conform to EN 13566-1.

8.3 Equipment

The equipment necessary for producing an SWO pipe is a winding machine, which is dedicated to a certain profiled plastics strip.

The relevant machine settings for each individual profile plastics strip and external diameter, d_e , of the SWO pipe shall be documented in the installation manual.

8.4 Installation

The SWO pipe shall be formed by the winding machine placed in front of the open end of the existing pipe (e.g. in a manhole).

EN 13566-7:2007 (E)

After insertion the SWO pipe shall be fixed in the existing pipeline by grouting the annular space.

NOTE The grouting procedure (which is outside the scope of this standard) should be designed to avoid any damage to the SWO pipe, excessive deformation or flotation of the pipe.

The installation manual shall specify all parameters and details necessary to guarantee a successful installation including the minimum temperature during the installation process.

8.5 Process-related inspection and testing

Process-related inspection and testing shall conform to EN 13566-1:2002, 8.5.

8.6 Lining termination

The installation manual shall specify how the locked seam is secured when cutting the profiled plastics strip to remove the winding machine.

8.7 Reconnecting to existing manholes and laterals

Reconnecting to existing manholes and laterals shall conform to EN 13566-1:2002, 8.7. Measures shall be taken to prevent grout entering the lateral pipes. These measures shall be documented in the installation manual.

8.8 Final inspection and testing

After grouting and reconnection of any laterals, the installed SWO pipe shall be inspected internally to verify that it is free from defects throughout its entire length.

8.9 Documentation

The documentation shall conform to EN 13566-1:2002, 8.9.

Annex A (informative)

Recommended scheme for assessment of conformity

A.1 Scope

The following text, read in conjunction with EN 13566-1:2002, Annex A, provides a recommended scheme for assessment of conformity of pipes, fittings and the installed lining system.

A.2 General

Materials, components, joints and the installed lining system should preferably be sampled and tested with the minimum frequencies given in this annex, in order to demonstrate conformity to the requirements of Clause 4, Clause 5 and Clause 7 of this standard, as applicable.

A.3 Testing and inspection

A.3.1 Material specification PVC

For the purposes of this standard the material specification consists of a recipe/compound which defines types of PVC and additives and their dosage levels.

The dosage level of ingredients of a material shall not exceed the tolerance bands given in Table A.1. If any level exceeds the dosage band or if a type is changed, this variation in formulation constitutes a change in material.

The manufacturer shall specify the values of the parts X to be added to 100 parts of PVC resin in his or her quality plan.

Table A.1 — Material specification PVC compound

Ingredients	Type	Band
PVC resin	Nominal K-value: as specified	$^{+3}_0$ units
Type and content of stabiliser or master batch	Pb CaZn Sn CaSn Others	$X_1: \pm 25 \%$
Lubricants	All	$X_2: \pm 50 \%$ for $X_2 \leq 0,2$
Fillers	CaCO ₃ Others	$X_3: \begin{matrix} 0 \\ -6 \end{matrix}$ parts $X_{4,1}: \begin{matrix} 0 \\ -50 \end{matrix} \%$ $X_{4,n}: \begin{matrix} 0 \\ -50 \end{matrix} \%$
Impact modifiers	All	$X_5: \pm 1$ part
Flow agents	All	$X_6: \pm 25 \%$ for $X_6 \leq 2$ $X_6: \pm 0,5$ parts for $X_6 > 2$
Pigments	—	No requirement
Others	To be separately specified by the manufacture	$X_{7,1}: \pm 25 \%$ $X_{7,n}: \pm 25 \%$

A.3.2 Grouping

No grouping applies; in principle each profiled plastics strip should be tested.

A.3.3 Type testing (TT)

Type testing should demonstrate that the products conform to all the characteristics given in Table A.2.

Each profiled plastics strip should be separately type tested.

Table A.2 — Characteristics of PVC-U profiled plastics strips and SWO pipes that require type testing

Characteristics	Ref. to clause	Minimum sampling	Number of samples	Number of test pieces
PROFILED PLASTICS STRIPS at the "M" stage				
Classification of seam sealant	4.1	Once/profiled strip	1	
Appearance	4.2	Once/profiled strip	1	1
Vicat B 50	4.6	Once/material/profiled strip	1	1
Charpy Impact strength	4.3		1	1
E-modulus (tensile)	4.3		1	1
Longitudinal tensile strength	4.3		1	1
Elongation at break	4.3		1	1
Geometrical characteristics	4.4	Once/profiled strip	2	1
SWO pipes at the "I" stage				
Ring stiffness	7.5	Once/profiled strip at its declared minimum and maximum diameters	2	2
Creep ratio	7.5		1	1
Tensile strength of a locked seam	7.5		1	1
Watertightness	7.7	Once/profiled strip	1	1

A.3.4 Batch release tests (BRT)

Batch release testing is relevant only for the profiled plastics strips at the "M" stage.

The characteristics given in Table A.2 should be applicable for batch release testing. The batch release tests should be carried out at a minimum sampling frequency given in Table A.3.

Table A.3 — Characteristics of profiled plastics strips that require batch release testing

Characteristics	Ref. to clause	Minimum sampling frequency	Number of test pieces
Appearance	4.2	every 2 h	1
Geometric characteristics	4.4	one/extrusion run	1

A.3.5 Process verification testing

Those characteristics and process-related inspection of testing specified in Clause 4, Clause 7 and Clause 8 should preferably be process verification tested with the minimum test frequencies, as given in Table A.4.

Table A.4 — Characteristics and minimum test frequencies that require PVT

Characteristics	Ref. to clause	Minimum test frequency
Geometric characteristics	4.4	Once/profile type
Geometric characteristics	7.4	Once/installed length
Leaktightness	8.5	Minimum once/project where specified

A.3.6 Audit testing tests (AT)

The characteristics given in Table A.5 should be applicable in "M" and "I" stage for audit testing.

Table A.5 — Characteristics of material PVC-U and profiled plastics strips/SWO pipes that require audit testing

Characteristics	Ref. to clause	Minimum test frequency
PROFILED PLASTICS STRIPS at the "M" stage		
Appearance	4.2	Once/year/profiled strip
Vicat B 50	4.6	
Charpy impact strength	4.3	
E-modulus (tensile)	4.3	
Longitudinal tensile strength	4.3	
Elongation at break	4.3	
Geometric characteristics	4.4	
Tensile strength of a locked seam	7.5	Once/5 years
SWO pipes at the "I" stage		
Ring stiffness	7.5	Once/3 years
Creep ratio	7.5	Once/5 years
Watertightness	7.7	Once/3 years

A.3.7 Indirect testing (IT)

Indirect testing is not applicable.

A.3.8 Inspection and test records

For inspection and test reports, EN 13566-1:2002, A.3.7 applies.

Annex B (normative)

Test method for watertightness of SWO pipes subject to bending

B.1 Scope

This annex specifies a test method for watertightness of SWO pipes with a bending radius.

B.2 Principle

A test piece of SWO pipe of a minimum of 5 m is sealed at its ends, placed on a flat surface and filled with water. During the test the SWO pipe is held in a fixed bent condition at a pre-determined longitudinal bending radius. The SWO pipe is subjected to internal water pressure for a certain period of time, during which it is continuously monitored for leakage. To pass the test the SWO pipe shall exhibit no leakage during the test period.

B.3 Apparatus

The apparatus is shown schematically in Figure B.1.

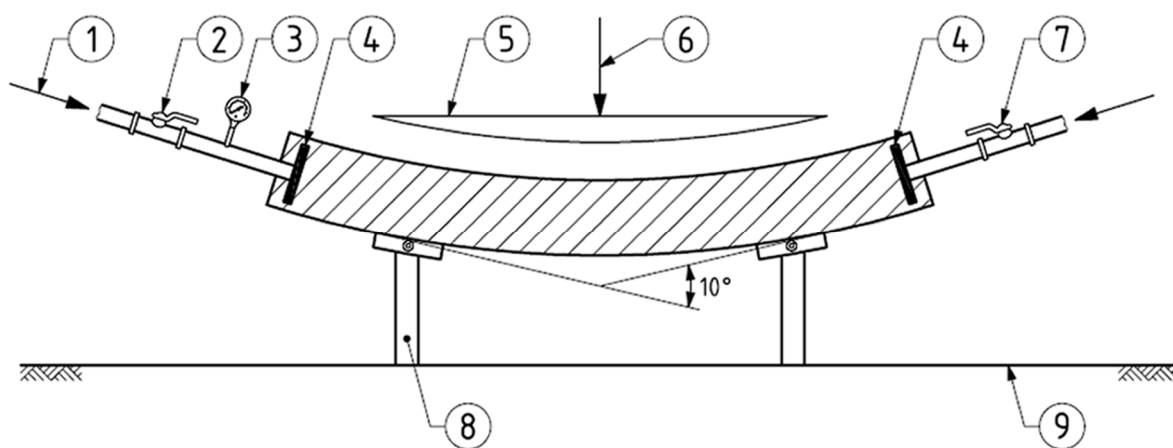

Key:

- | | |
|---|--|
| 1 connection to pressurisation device (e.g. pump) | 6 applied load |
| 2 closure valve | 7 air release valve |
| 3 pressure gauge | 8 pipe support with self aligning saddle |
| 4 sealing device | 9 flat surface |
| 5 fixed radius loading element | |

Figure B.1 — Horizontal projection of SWO pipe showing schematic test layout

The apparatus used for watertightness testing shall comprise:

- a) **compression testing machine**, with a semi-circular fixed radius loading element attached as shown in Figure B.1. The length and applied load on the semi-circular radius of the loading element shall produce an angular deflection bending radius of 10° of the SWO pipe between its supports as shown in Figure B.1;
- b) **flat surface**;
- c) **supports with self-aligning saddles**, mounted on the flat surface, with a distance between the supports the greater of $7 \times d_e$ and 3,5 m;
- d) **internal sealing devices** (e.g. inflatable plugs), capable of carrying the forces due to the internal test pressure;
- e) **devices for filling with water and for releasing of air**, each including a closure valve;
- f) **pressure gauge**, calibrated to be read accurately to the nearest 0,001 MPa;
- g) **pressurisation device** (e.g. a pump);
- h) **chronometer**;
- i) **ultraviolet light detection system**.

B.4 Test piece

The minimum of the SWO pipe length between the sealing elements shall be the greater of $10 \times d_e$ and 5 m.

The ends of samples cut from SWO pipes for testing purposes shall be secured as appropriate to prevent opening of the locked seam.

The length and applied load on the semi-circular radius of the loading element shall be such as to produce an angular deflection bending radius of 10° of the SWO pipe between its supports, as shown in Figure B.1.

B.5 Test temperature

The test shall be carried out at a temperature of $(23 \pm 2)^\circ\text{C}$, and any change of temperature during the test shall not exceed $\pm 2^\circ\text{C}$.

B.6 Test procedure

B.6.1 Measure and record the dimensions of the test piece and mount the test piece on the flat surface, see Figure B.1.

B.6.2 Apply and record the load on the semi-circular radius of the loading element to produce an angular deflection bending radius of 10° of the SWO pipe between its supports, as shown in Figure B.1.

B.6.3 During the steps B.6.4 through B.6.8, continuously monitor the outer surface of the SWO pipe for any signs of leakage of the fluorescent dyed water with the aid of ultraviolet light and record any leakage or weeping and the pressure level at which the event occurred.

B.6.4 Fill the test piece with water mixed with a fluorescent dye and vent all air.

B.6.5 Keep the test piece filled with water at atmospheric pressure for 5 min before closing the air release valve.

B.6.6 Gradually raise the internal pressure to +0,05 MPa in not less than 5 min and maintain and monitor this pressure for 15 min, the pressure level being measured at the air release valve. If necessary, adjust the internal pressure to compensate for expansion of the test piece.

B.6.7 Gradually lower the pressure to -0,05 MPa in not less than 5 min and maintain and monitor this pressure for 15 min, the pressure level being measured at the air release valve. If necessary, adjust the internal pressure to compensate for contraction of the test piece.

B.6.8 Return to atmospheric pressure in not less than 5 min.

B.7 Requirements

The outer surface of the SWO pipe shall remain free of visible leakage or weeping for the whole of the test period. A leakage or weeping should be detectable under the ultraviolet light.

B.8 Test Report

The test report shall include the following information:

- a) reference to this standard;
- b) name of the profiled plastics strip supplier and the dedicated winding machine;
- c) type/code and declared values of the profiled plastics strip;
- d) date of production of SWO pipe;
- e) measured dimensions of the test piece;
- f) load and radius applied to the test piece;
- g) test temperature and any variation during the test;
- h) graph of internal pressure versus time;
- i) any signs of leakage or weeping during the test period and associated pressure level;
- j) any factors that could have affected the results, such as any incidents, test interruptions or any operating details not specified in this standard;
- k) date of test.

Bibliography

- [1] ISO/TR 11295, Techniques for rehabilitation of pipeline systems by the use of plastics pipes and fittings
- [2] EN 13689, Guidance on the classification and design of plastics piping systems used for renovation
- [3] DIN 16970, Adhesives for bonding pipes and pipe system elements of rigid PVC, general quality requirements and testings.

BSI — British Standards Institution

BSI is the independent national body responsible for preparing British Standards. It presents the UK view on standards in Europe and at the international level. It is incorporated by Royal Charter.

Revisions

British Standards are updated by amendment or revision. Users of British Standards should make sure that they possess the latest amendments or editions.

It is the constant aim of BSI to improve the quality of our products and services. We would be grateful if anyone finding an inaccuracy or ambiguity while using this British Standard would inform the Secretary of the technical committee responsible, the identity of which can be found on the inside front cover.
Tel: +44 (0)20 8996 9000. Fax: +44 (0)20 8996 7400.

BSI offers members an individual updating service called PLUS which ensures that subscribers automatically receive the latest editions of standards.

Buying standards

Orders for all BSI, international and foreign standards publications should be addressed to Customer Services. Tel: +44 (0)20 8996 9001.
Fax: +44 (0)20 8996 7001. Email: orders@bsi-global.com. Standards are also available from the BSI website at <http://www.bsi-global.com>.

In response to orders for international standards, it is BSI policy to supply the BSI implementation of those that have been published as British Standards, unless otherwise requested.

Information on standards

BSI provides a wide range of information on national, European and international standards through its Library and its Technical Help to Exporters Service. Various BSI electronic information services are also available which give details on all its products and services. Contact the Information Centre.
Tel: +44 (0)20 8996 7111. Fax: +44 (0)20 8996 7048. Email: info@bsi-global.com.

Subscribing members of BSI are kept up to date with standards developments and receive substantial discounts on the purchase price of standards. For details of these and other benefits contact Membership Administration.
Tel: +44 (0)20 8996 7002. Fax: +44 (0)20 8996 7001.
Email: membership@bsi-global.com.

Information regarding online access to British Standards via British Standards Online can be found at <http://www.bsi-global.com/bsonline>.

Further information about BSI is available on the BSI website at <http://www.bsi-global.com>.

Copyright

Copyright subsists in all BSI publications. BSI also holds the copyright, in the UK, of the publications of the international standardization bodies. Except as permitted under the Copyright, Designs and Patents Act 1988 no extract may be reproduced, stored in a retrieval system or transmitted in any form or by any means – electronic, photocopying, recording or otherwise – without prior written permission from BSI.

This does not preclude the free use, in the course of implementing the standard, of necessary details such as symbols, and size, type or grade designations. If these details are to be used for any other purpose than implementation then the prior written permission of BSI must be obtained.

Details and advice can be obtained from the Copyright & Licensing Manager.
Tel: +44 (0)20 8996 7070. Fax: +44 (0)20 8996 7553.
Email: copyright@bsi-global.com.