

**Plastics piping systems for
non-pressure underground
drainage and sewerage —
Structured-wall piping
systems of unplasticized
poly(vinyl chloride) (PVC-U),
polypropylene (PP) and
polyethylene (PE) —**

**Part 2: Specifications for pipes and
fittings with smooth internal and
external surface and the system, Type A**

The European Standard EN 13476-2:2007 has the status of a
British Standard

ICS 23.040.20; 93.030

National foreword

This British Standard is the UK implementation of EN 13476-2:2007. It does not supersede any current British Standards. However, the Water Industry has indicated that following the publication of this British Standard, Industry Specification WIS 4-35-01 will be declared obsolescent by 29 May 2009 and retained for reference where applicable.

The UK participation in its preparation was entrusted by Technical Committee PRI/88, Plastics piping systems and components, to Subcommittee PRI/88/1, Thermoplastics piping systems and components for non-pressure applications.

A list of organizations represented on this subcommittee can be obtained on request to its secretary.

Sewerage undertakers and other entities deemed to be within the scope of the Public Procurement Directive (PPD) are obliged to use Parts 1 to 3 of this series of European Standards, produced under EC/U mandate, if they are to comply with structured wall pipe systems or components within its scope. National Annex NA (informative) gives additional guidance on the use of Parts 1 to 3 of BS EN 13476:2007.

This publication does not purport to include all the necessary provisions of a contract. Users are responsible for its correct application.

Compliance with a British Standard cannot confer immunity from legal obligations.

This British Standard was published under the authority of the Standards Policy and Strategy Committee on 31 July 2007

© BSI 2007

ISBN 978 0 580 53623 6

Amendments issued since publication

Amd. No.	Date	Comments

ICS 93.030

English Version

Plastics piping systems for non-pressure underground drainage and sewerage - Structured-wall piping systems of unplasticized poly(vinyl chloride) (PVC-U), polypropylene (PP) and polyethylene (PE) - Part 2: Specifications for pipes and fittings with smooth internal and external surface and the system, Type A

Systèmes de canalisations en plastiques pour les branchements et les collecteurs d'assainissement sans pression enterrés - Systèmes de canalisations à parois structurées en poly(chlorure de vinyle) non plastifié (PVC-U), polypropylène (PE) - Partie 2: Spécifications pour les tubes et raccords avec une surface interne et externe lisse et le système, de Type A

Kunststoff-Rohrleitungssysteme für erdverlegte drucklose Abwasserkanäle und -leitungen - Rohrleitungssysteme mit profilierter Wandung aus weichmacherfreiem Polyvinylchlorid (PVC-U), Polypropylen (PP) und Polyethylen (PE) - Teil 2: Anforderungen an Rohre und Formstücke mit glatter Innen- und Außenfläche und an das Rohrleitungssystem, Rohrtyp A

This European Standard was approved by CEN on 5 March 2007.

CEN members are bound to comply with the CEN/CENELEC Internal Regulations which stipulate the conditions for giving this European Standard the status of a national standard without any alteration. Up-to-date lists and bibliographical references concerning such national standards may be obtained on application to the CEN Management Centre or to any CEN member.

This European Standard exists in three official versions (English, French, German). A version in any other language made by translation under the responsibility of a CEN member into its own language and notified to the CEN Management Centre has the same status as the official versions.

CEN members are the national standards bodies of Austria, Belgium, Bulgaria, Cyprus, Czech Republic, Denmark, Estonia, Finland, France, Germany, Greece, Hungary, Iceland, Ireland, Italy, Latvia, Lithuania, Luxembourg, Malta, Netherlands, Norway, Poland, Portugal, Romania, Slovakia, Slovenia, Spain, Sweden, Switzerland and United Kingdom.



EUROPEAN COMMITTEE FOR STANDARDIZATION
COMITÉ EUROPÉEN DE NORMALISATION
EUROPÄISCHES KOMITEE FÜR NORMUNG

Management Centre: rue de Stassart, 36 B-1050 Brussels

Contents	Page
Foreword	4
Introduction	5
1 Scope	6
2 Normative references	6
3 Terms, definitions, symbols and abbreviations	8
3.1 Symbols	8
3.2 Abbreviations	9
4 Material	10
4.1 General	10
4.2 Unplasticized poly(vinyl chloride) (PVC-U).....	10
4.3 Polypropylene (PP).....	11
4.4 Polyethylene (PE).....	12
4.5 Sealing rings	14
4.6 Fused or welded joints	14
4.7 Adhesives for PVC-U	14
5 Designation of wall constructions and examples of typical jointing methods	15
5.1 General	15
5.2 Wall constructions designated as Type A.....	15
5.3 Designation and design of joints	16
6 Appearance and colour	16
7 Geometrical characteristics	16
7.1 General	16
7.2 Dimensions	16
7.3 Types of fittings.....	22
7.4 Design length of fittings.....	22
8 Physical characteristics	22
8.1 Unplasticized poly(vinyl chloride) (PVC-U).....	22
8.2 Polypropylene (PP).....	23
8.3 Polyethylene (PE).....	24
9 Mechanical characteristics	25
9.1 Mechanical characteristics of pipes	25
9.2 Mechanical characteristics of fittings	27
10 Performance Requirements	28
11 Marking	30
11.1 General	30
11.2 Minimum required marking	30
11.3 Additional marking	31
Annex A (normative) Virgin PVC-U material	32
Annex B (normative) Utilisation of non-virgin PVC-U material	33
B.1 Reprocessable and recyclable material from pipes and fittings	33
B.2 External reprocessable and recyclable materials with agreed specifications.....	33
B.3 External reprocessable and recyclable materials not covered by an agreed specification	34
Annex C (normative) Virgin PP material	36

Annex D (normative) Utilisation of non-virgin PP material	37
D.1 Reprocessable and recyclable material from pipes and fittings	37
D.2 External reprocessible and recyclable materials with an agreed specification	37
D.3 External reprocessible and recyclable materials not covered by an agreed specification	37
Annex E (normative) Virgin PE material.....	38
Annex F (normative) Utilisation of non-virgin PE material	39
F.1 Reprocessable and recyclable material from pipes and fittings	39
F.2 External reprocessible and recyclable materials with an agreed specification	39
F.3 External reprocessible and recyclable materials not covered by an agreed specification	39
F.4 External reprocessible and recyclable material from PE rotational-moulded fittings and other components	40
Annex G (normative) Impact test at 23 °C.....	41
Annex H (normative) Impact test at – 10 °C.....	42
Annex I (normative) Ring flexibility test at 20 % diametric deflection	43
Annex J (informative) Survey of possible use of reprocessible and recyclable material	44
National Annex NA (informative) to BS EN 13476-2:2007	
Additional guidance for UK users	45

Foreword

This document (EN 13476-2:2007) has been prepared by Technical Committee CEN/TC 155 “Plastics piping systems and ducting systems”, the secretariat of which is held by NEN.

This European Standard shall be given the status of a national standard, either by publication of an identical text or by endorsement, at the latest by November 2007, and conflicting national standards shall be withdrawn at the latest by November 2007.

This standard is a part of a System Standard for plastics piping systems of particular materials for a specified application. There are a number of such System Standards.

System Standards are based on the results of the work being undertaken in ISO/TC 138 “Plastics pipes, fittings and valves for the transport of fluids”, which is a Technical Committee of the International Organization for Standardization (ISO).

They are supported by separate standards on test methods to which references are made throughout the System Standard.

The System Standards are consistent with general standards on functional requirements and on recommended practice for installation.

EN 13476 consists of the following Parts under the general title Plastics piping systems for non-pressure underground drainage and sewerage — Structured-wall piping systems of unplasticized poly(vinyl chloride) (PVC-U), polypropylene (PP) and polyethylene (PE)

- *Part 1: General requirements and performance characteristics;*
- *Part 2: Specifications for pipes and fittings with smooth internal and external surface and the system, Type A (this standard);*
- *Part 3: Specifications for pipes and fittings with a smooth internal surface and profiled external surface and the system, Type B;*
- *Part 4: Assessment of conformity (CEN/TS);*
- *Part 5: Guidance for installation (CEN/TS).¹*

For pipes and fittings which have conformed to the relevant national standard before May 2007, as shown by the manufacturer or by a certification body, the national standard may continue to be applied until May 2009.

National standards specifically for pipes and fittings for the transport of surface water are not considered to be conflicting with this standard and may thus be allowed to coexist.

According to the CEN/CENELEC Internal Regulations, the national standards organizations of the following countries are bound to implement this European Standard: Austria, Belgium, Bulgaria, Cyprus, Czech Republic, Denmark, Estonia, Finland, France, Germany, Greece, Hungary, Iceland, Ireland, Italy, Latvia, Lithuania, Luxembourg, Malta, Netherlands, Norway, Poland, Portugal, Romania, Slovakia, Slovenia, Spain, Sweden, Switzerland and United Kingdom.

¹ The feasibility of this project is under study.

Introduction

This standard provides optional choices for impact resistance (see Annex G and Annex H) and ring flexibility, see Annex I.

As appropriate, the individual countries may select between those options in their national forewords.

1 Scope

This part of EN 13476, together with EN 13476-1, specifies the definitions and requirements for pipes, fittings and the system based on unplasticized poly(vinyl chloride) (PVC-U), polypropylene (PP) and polyethylene (PE) structured-wall piping systems that are intended to be used for non-pressure underground drainage and sewerage systems.

This part is applicable to pipes and fittings with smooth internal and external surfaces, designated as Type A.

It specifies test methods and test parameters as well as requirements.

This part is applicable to:

- a) structured-wall pipes and fittings, which are intended to be used buried underground outside the building structure; reflected in the marking of products by "U";
- b) structured-wall pipes and fittings, which are intended to be used buried underground both outside (application area code "U") and within the building structure (application area code "D"); reflected in the marking of products by "UD".

This part is applicable to structured-wall pipes and fittings with or without an integral socket with elastomeric ring seal joints as well as welded and fused joints.

This part covers a range of pipe and fitting sizes, materials, pipe constructions, stiffness classes, application classes, and tolerance classes and gives recommendations concerning colours.

NOTE 1 It is the responsibility of the purchaser or specifier to make the appropriate selections from these aspects, taking into account their particular requirements and any relevant national regulations and installation practices or codes.

NOTE 2 For dimensions larger than DN 1200 OD/ID this document may be applied regarding appearance, colour, physical and mechanical characteristics as well as performance requirements.

2 Normative references

The following referenced documents are indispensable for the application of this document. For dated references, only the edition cited applies. For undated references, the latest edition of the referenced document (including any amendments) applies.

EN 476, *General requirements for components used in discharge pipes, drains and sewers for gravity systems*

EN 580, *Plastics piping systems — Unplasticized poly(vinyl chloride) (PVC-U) pipes — Test method for the resistance to dichloromethane at a specified temperature (DCMT)*

EN 681-1, *Elastomeric seals — Materials requirements for pipe joint seals used in water and drainage applications — Part 1: Vulcanized rubber*

EN 681-2, *Elastomeric seals — Materials requirements for pipe joint seals used in water and drainage applications — Part 2: Thermoplastic elastomers*

EN 681-4, *Elastomeric seals — Materials requirements for pipe joint seals used in water and drainage applications — Part 4: Cast polyurethane sealing elements*

EN 727, *Plastics piping and ducting systems — Thermoplastics pipes and fittings — Determination of Vicat softening temperature (VST)*

EN 728, *Plastics piping and ducting systems — Polyolefin pipes and fittings — Determination of oxidation induction time*

- EN 744, *Plastics piping and ducting systems — Thermoplastics pipes — Test method for resistance to external blows by the round-the-clock method*
- EN 922, *Plastics piping and ducting systems — Pipes and fittings of unplasticized poly(vinyl chloride) (PVC-U) — Specimen preparation for determination of the viscosity number and calculation of the K-value*
- EN 1053, *Plastics piping systems — Thermoplastics piping systems for non-pressure applications — Test method for watertightness*
- EN 1055:1996, *Plastics piping systems — Thermoplastics piping systems for soil and waste discharge inside buildings — Test method for resistance to elevated temperature cycling*
- EN 1277, *Plastics piping systems — Thermoplastics piping systems for buried non-pressure applications — Test methods for leaktightness of elastomeric sealing ring type joints*
- EN 1401-1, *Plastics piping systems for non-pressure underground drainage and sewerage — Unplasticized poly(vinyl chloride) (PVC-U) — Part 1: Specifications for pipes, fittings and the system*
- EN 1411, *Plastics piping and ducting systems — Thermoplastics pipes — Determination of resistance to external blows by the staircase method*
- EN 1437, *Plastics piping systems — Piping systems for underground drainage and sewerage — Test method for resistance to combined temperature cycling and external loading*
- EN 1446, *Plastics piping and ducting systems — Thermoplastics pipes — Determination of ring flexibility*
- EN 1852-1, *Plastics piping systems for non-pressure underground drainage and sewerage — Polypropylene (PP) — Part 1: Specifications for pipes, fittings and the system*
- EN 1905, *Plastics piping systems — Unplasticized poly(vinyl chloride) (PVC-U) pipes, fittings and material — Method for assessment of the PVC content based on total chlorine content*
- EN 1979, *Plastics piping and ducting systems — Thermoplastics spirally-formed structured-wall pipes — Determination of the tensile strength of a seam*
- EN 12061, *Plastics piping systems — Thermoplastics fittings — Test method for impact resistance*
- EN 12256, *Plastics piping systems — Thermoplastics fittings — Test method for mechanical strength or flexibility of fabricated fittings*
- EN 12666-1, *Plastics piping systems for non-pressure underground drainage and sewerage — Polyethylene (PE) — Part 1: Specifications for pipes, fittings and the system*
- EN 13476-1:2007, *Plastics piping systems for non-pressure underground drainage and sewerage — Structured-wall piping systems of unplasticized poly(vinyl chloride) (PVC-U), polypropylene (PP) and polyethylene (PE) — Part 1: General requirements and performance characteristics*
- EN 13476-3, *Plastics piping systems for non-pressure underground drainage and sewerage — Structured-wall piping systems of unplasticized poly(vinyl chloride) (PVC-U), polypropylene (PP) and polyethylene (PE) — Part 3: Specifications for pipes and fittings with smooth internal and profiled external surface and the system, Type B*
- CEN/TS 14541:2007, *Plastics pipes and fittings for non-pressure applications — Utilisation of non-virgin PVC-U, PP and PE materials*
- EN 14741, *Thermoplastics piping and ducting systems — Joints for buried non-pressure applications — Test method for the long-term sealing performance of joints with elastomeric seals by estimating the sealing pressure*

EN 14758-1, *Plastics piping systems for non-pressure underground drainage and sewerage — Polypropylene with mineral modifiers (PP-MD) — Part 1: Specifications for pipes, fittings and the system*

EN ISO 580, *Plastics piping and ducting systems — Injection-moulded thermoplastics fittings — Methods for visually assessing the effects of heating (ISO 580:2005)*

EN ISO 1133:2005, *Plastics — Determination of the melt mass-flow rate (MFR) and the melt volume-flow rate (MVR) of thermoplastics (ISO 1133:2005)*

EN ISO 1167-1, *Thermoplastics pipes, fittings and assemblies for the conveyance of fluids — Determination of the resistance to internal pressure — Part 1: General method (ISO 1167-1:2006)*

EN ISO 1167-2, *Thermoplastics pipes, fittings and assemblies for the conveyance of fluids — Determination of the resistance to internal pressure — Part 2: Preparation of pipe test pieces (ISO 1167-2:2006)*

EN ISO 1183-1, *Plastics — Methods for determining the density of non-cellular plastics — Part 1: Immersion method, liquid pycnometer and titration method (ISO 1183-1:2004)*

EN ISO 2505, *Thermoplastics pipes — Longitudinal reversion — Test method and parameters (ISO 2505:2005)*

EN ISO 3126, *Plastics piping systems — Plastics piping components — Determination of dimensions (ISO 3126:2005)*

EN ISO 3451-1, *Plastics—Determination of ash — Part 1: General methods (ISO 3451-1:1997)*

EN ISO 9967, *Plastics pipes — Determination of creep ratio (ISO 9967:1994)*

EN ISO 9969, *Thermoplastics pipes — Determination of ring stiffness (ISO 9969:1994)*

ISO 13967, *Thermoplastics fittings — Determination of ring stiffness*

3 Terms, definitions, symbols and abbreviations

For the purposes of this document, the terms and definitions given in EN 13476-1:2007 apply.

3.1 Symbols

A	length of engagement, or maximum pull-out whilst maintaining tightness
C	length of the sealing zone
d_e	outside diameter
d_{em}	mean outside diameter
d_{im}	mean inside diameter
d_n	nominal diameter
$d_{sm,min}$	minimum mean inside diameter of socket
e	wall thickness (at any point)
e_c	construction height
e_{min}	minimum wall thickness of pipe or spigot
e_2	wall thickness at any point of the cylindrical part of a socket

e_3	wall thickness at any point of a sealing ring groove of a socket
e_4	wall thickness of the inside layer (waterway wall thickness)
e_5	wall thickness of the inside layer under a hollow section
l	effective length of a pipe
$L_{1,\min}$	minimum length of a spigot
IMP 23C	impact resistance determined at +23 °C
❄	impact resistance determined at –10 °C

3.2 Abbreviations

CaCO_3	calcium carbonate
CT	close tolerance
DN	nominal size
DN/ID	nominal size related to inside diameter
DN/OD	nominal size related to outside diameter
H50	value for impact resistance of a pipe
MgCO_3	magnesium carbonate
$\text{Mg}_3\text{Si}_4\text{O}_{10}(\text{OH})_2$	magnesium silicate, talcum
MFR	melt mass-flow rate
OIT	oxidation induction time
PE	polyethylene
PP	polypropylene
PP-MD	mineral modified PP
PVC-U	unplasticized poly(vinyl chloride)
RF	ring flexibility performance
S	pipe series S
SDR	standard dimension ratio
SN	ring stiffness class

TIR	true impact rate
TPE	thermo plastic elastomer
VST	Vicat softening temperature

4 Material

4.1 General

The material shall be one of the following: unplasticized poly(vinyl chloride) (PVC-U), polypropylene (PP) or polyethylene (PE), to which are added additives needed to facilitate the manufacture of components conforming to this document, including the relevant annexes.

4.2 Unplasticized poly(vinyl chloride) (PVC-U)

4.2.1 General

The raw material shall be PVC-U to which are added additives needed to facilitate the manufacture of components conforming to the requirements of this document (see also Annex A).

NOTE Additional information on the characteristics of PVC-U material or components is given in Annex A of EN 13476-1:2007.

4.2.2 Pipe and fitting material characteristics

When tested in accordance with the test method as specified in Table 1 using the indicated parameters, the material shall have characteristics conforming to the requirements given in Table 1.

Table 1 — Material characteristics of PVC-U pipes and injection-moulded fittings

Characteristic	Requirements	Test parameters		Test method
Resistance to internal pressure <small>a b c</small>	No failure during the test period	End caps Orientation Number of test pieces Test temperature Circumferential stress - pipe material - fitting material Conditioning period Type of test Test period	Type A or Type B Free 3 60 °C 10 MPa 6,3 MPa Shall conform to EN ISO 1167-1 Water-in-water 1 000 h	EN ISO 1167-1 and EN ISO 1167-2
<p><small>a</small> This requirement does not apply to the specified intermediate layer of a Type A1 pipe.</p> <p><small>b</small> For the extrusion compounds for the internal and external layers of a multilayer pipe, this test shall be carried out in the form of a solid wall pipe made from the relevant material(s).</p> <p><small>c</small> For injection-moulding compounds, this test shall be carried out in the form of an injection-moulded or extruded sample in solid wall pipe form made from the relevant material.</p>				

4.2.3 Utilisation of non-virgin materials

For the utilisation of non-virgin PVC-U materials, conditions and requirements are given in Annex B.

NOTE Annex J offers a survey of the possible use of reprocessible and recyclable materials.

4.3 Polypropylene (PP)

4.3.1 General

The compound for pipes and fittings shall be PP based material to which are added additives needed to facilitate the manufacture of components conforming to the requirements of this document. See also Annex C.

NOTE Additional information of the characteristics of PP material or components made thereof is given in Annex A of EN 13476-1:2007.

4.3.2 Pipe and fitting material characteristics

When tested in accordance with the test methods as specified in Table 2 using the indicated parameters, the material shall have characteristics conforming to the requirements given in Table 2.

Table 2 — Material characteristics of PP pipes and injection-moulded fittings

Characteristic	Requirements	Test parameters		Test method
Resistance to internal pressure, 140 h ^{a b c}	No failure during the test period	End caps Test temperature Orientation Number of test pieces Circumferential stress Conditioning period Type of test Test period	Type A or Type B 80 °C Free 3 4,2 MPa Shall conform to EN ISO 1167-1 Water-in-water 140 h	EN ISO 1167-1 and EN ISO 1167-2
Resistance to internal pressure 1000 h ^{a b c}	No failure during the test period	End caps Test temperature Orientation Number of test pieces Circumferential stress Conditioning period Type of test Test period	Type A or Type B 95 °C Free 3 2,5 MPa Shall conform to EN ISO 1167-1 Water-in-water 1 000 h	EN ISO 1167-1 and EN ISO 1167-2
Melt mass-flow rate	≤ 1,5 g/10 min	Temperature Loading mass	230 °C 2,16 kg	EN ISO 1133:2005 condition M
Thermal stability, OIT ^d	≥ 8 min	Temperature	200 °C	EN 728
<p>^a This requirement does not apply to the specified intermediate layer of a Type A1 pipe.</p> <p>^b For the extrusion compounds for the internal and external layers of a multilayer pipe, this test shall be carried out in the form of a solid wall pipe made from the relevant material(s).</p> <p>^c For injection-moulding compounds this test shall be carried out in the form of an injection-moulded, or extruded sample in solid wall pipe form made from the relevant material.</p> <p>^d This requirement is only valid for pipes and fittings intended to be jointed in field by fusing or welding.</p>				

4.3.3 Melt mass-flow rate classification

Materials for pipes and fittings intended for in field jointing by fusion or welding, shall be designated by the following MFR classes:

- Class A: MFR ≤ 0,3 g/10 min;
- Class B: 0,3 g/10 min < MFR ≤ 0,6 g/10 min;
- Class C: 0,6 g/10 min < MFR ≤ 0,9 g/10 min;
- Class D: 0,9 g/10 min < MFR ≤ 1,5 g/10 min.

In the case where a raw material, because of its MFR tolerance arbitrarily falls in one of two adjacent classes, the manufacturer of the components may mark the MFR class on the product as follows:

- MFR value across the border between A and B it is permitted to classify as class A;
- MFR value across the border between B and C it is permitted to classify as class C;
- MFR value across the border between C and D it is permitted to classify as class D.

4.3.4 Utilisation of non-virgin materials

For the utilisation of non-virgin PP materials, conditions and requirements are given in Annex D.

NOTE Annex J gives a survey of the possible use of reprocessible and recyclable materials.

4.4 Polyethylene (PE)

4.4.1 General

The base material shall be polyethylene (PE) to which are added additives needed to facilitate the manufacture of components conforming to this document. See also Annex E.

NOTE Additional information of the characteristics of PE material or components is given in EN 13476-1.

4.4.2 Material characteristics of pipes and injection-moulded fittings

When tested in accordance with the test method as specified in Table 3 using the indicated parameters, the material shall have characteristics conforming to the requirements given in Table 3.

Table 3 — Material characteristics of PE pipes and injection-moulded fittings

Characteristic	Requirements	Test parameters		Test method
Resistance to internal pressure 165 h ^{a,b,c}	No failure during the test period	End caps Test temperature Orientation Number of test pieces Circumferential stress Conditioning period Type of test Test period	Type A or Type B 80 °C Free 3 4,0 MPa Shall conform to EN ISO 1167-1 Water-in-water 165 h	EN ISO 1167-1 and EN ISO 1167-2
Resistance to internal pressure 1 000 h ^{a,b,c}	No failure during the test period	End caps Test temperature Orientation Number of test pieces Circumferential stress Conditioning period Type of test Test period	Type A or Type B 80 °C Free 3 2,8 MPa Shall conform to EN ISO 1167-1 Water-in-water 1 000 h	EN ISO 1167-1 and EN ISO 1167-2
Melt mass-flow rate	≤ 1,6 g/10 min	Temperature Loading mass	190 °C 5 kg	EN ISO 1133:2005 condition T
Thermal stability, OIT ^d	≥ 20 min	Temperature	200 °C	EN 728
Reference density	≥ 930 kg/m ³	Shall conform to EN ISO 1183-1		EN ISO 1183-1
<p>^a This requirement does not apply to the specified intermediate layer of a Type A1 pipe.</p> <p>^b For the extrusion compounds for the internal and external layers of a multilayer pipe this test shall be carried out in the form of a solid wall pipe made from the relevant material(s).</p> <p>^c For injection-moulding compounds this test shall be carried out in the form of an injection-moulded, or extruded sample in solid wall pipe form made from the relevant material.</p> <p>^d This requirement is only valid for pipes and fittings intended to be jointed in field by fusing or welding.</p>				

4.4.3 Material characteristics of rotational-moulded fittings

When tested in accordance with the test methods as specified in Table 4 using the indicated parameters, the material shall have characteristics conforming to the requirements given in Table 4

Table 4 — Material characteristics of PE rotational-moulded fittings

Characteristic	Requirements	Test parameters		Test
Resistance to internal pressure 165 h ^a	No failure during the test period	End caps Orientation Number of test pieces Temperature Circumferential stress Conditioning period	Type A or Type B Free 3 60 °C 3,9 MPa Shall conform to EN ISO 1167-1 Water-in-water 165 h	EN ISO 1167-1 and EN ISO 1167-2
Resistance to internal pressure 1000 h ^a	No failure during the test period	End caps Orientation Number of test pieces Temperature Circumferential stress Conditioning period	Type A or Type B Free 3 60 °C 3,2 MPa Shall conform to EN ISO 1167-1 Water-in-water 1000 h	EN ISO 1167-1 and EN ISO 1167-2
Melt mass-flow rate	3 g/10 min ≤ MFR ≤ 16 g/10 min	Temperature Loading mass	190 °C 5 Kg	EN ISO 1133:2005 Condition T
Thermal stability	≥ 10 min	Temperature	200 °C	EN 728
Density	≥ 925 kg/m ³	Temperature	(23 ± 2) °C	EN ISO 1183-1
^a This test shall be carried out in the form of an injection-moulded, or extruded sample in solid wall pipe form made from the relevant material.				

4.4.4 Utilisation of non-virgin materials

For the utilisation of non-virgin PE materials, conditions and requirements are given in Annex F.

NOTE Annex J gives a survey of the possible use of reprocessible and recyclable materials.

4.4.5 Sealing ring retaining components

It is permitted that sealing rings are retained using components made from any polymer.

4.5 Sealing rings

The sealing ring material shall conform to EN 681-1, EN 681-2 or EN 681-4, as applicable.

The sealing ring shall have no detrimental effects on the properties of the components and shall not cause the test assembly to fail the performance requirements given in clause 10.

4.6 Fused or welded joints

The design of fused or welded joints together with the manufacturer's instructions for the jointing process shall not cause the test assembly to fail the performance requirements given in clause 10.

4.7 Adhesives for PVC-U

The adhesive for jointing of PVC-U shall be solvent cement and shall be as specified by the manufacturer of the pipes or fittings where appropriate.

The adhesive shall have no detrimental effects on the properties of components and shall not cause the test assembly to fail the performance requirements given in Clause 10.

5 Designation of wall constructions and examples of typical jointing methods

5.1 General

NOTE The figures are schematic sketches only to indicate the relevant dimensions. They do not necessarily represent the manufactured components.

5.2 Wall constructions designated as Type A

5.2.1 Multilayer construction or hollow-wall construction with axial hollow sections, Type A1 constructions

A pipe or fitting with a smooth internal and external surface and in which the outer and inner walls are connected by internal axial ribs or a foamed or non-foamed intermediate layer of thermoplastics, shall be designated Type A1.

Typical examples of Type A1 constructions are shown in Figure 1.

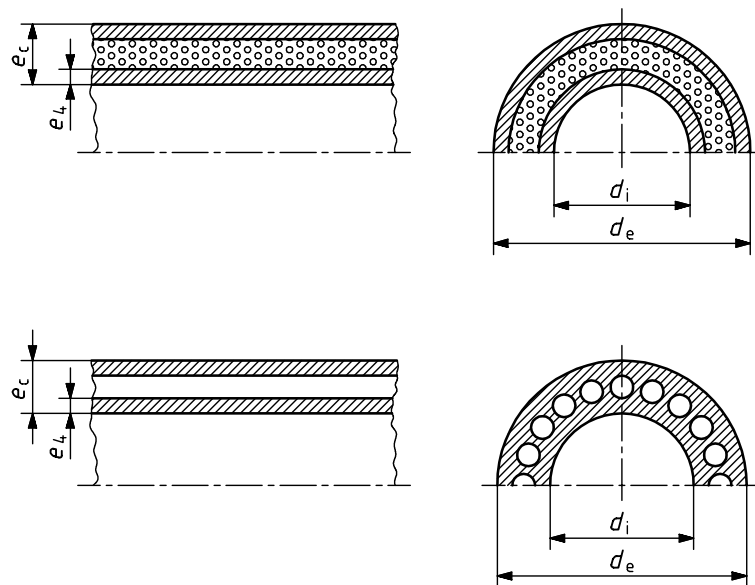

Figure 1 — Typical examples of wall construction Type A1

5.2.2 Hollow-wall construction with spirally or radial formed hollow sections, Type A2 construction

A pipe or fitting with a smooth inside and external surface and in which the outer and inner walls are connected by internal spiral or radial formed ribs, shall be designated Type A2.

A typical example of Type A2 constructions is shown in Figure 2.

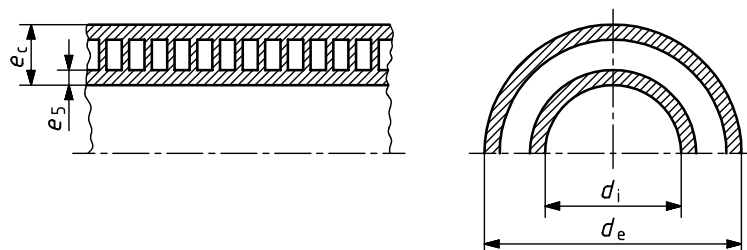

Figure 2 — Typical example of wall construction Type A2

5.2.3 Typical jointing methods for structured-wall pipes Type A

Relevant dimensions for typical joints of Type A pipes are shown in Figure 3. When factory mounted sealing rings are used, dimensions *A* and *C* may be defined relative to the effective sealing point.

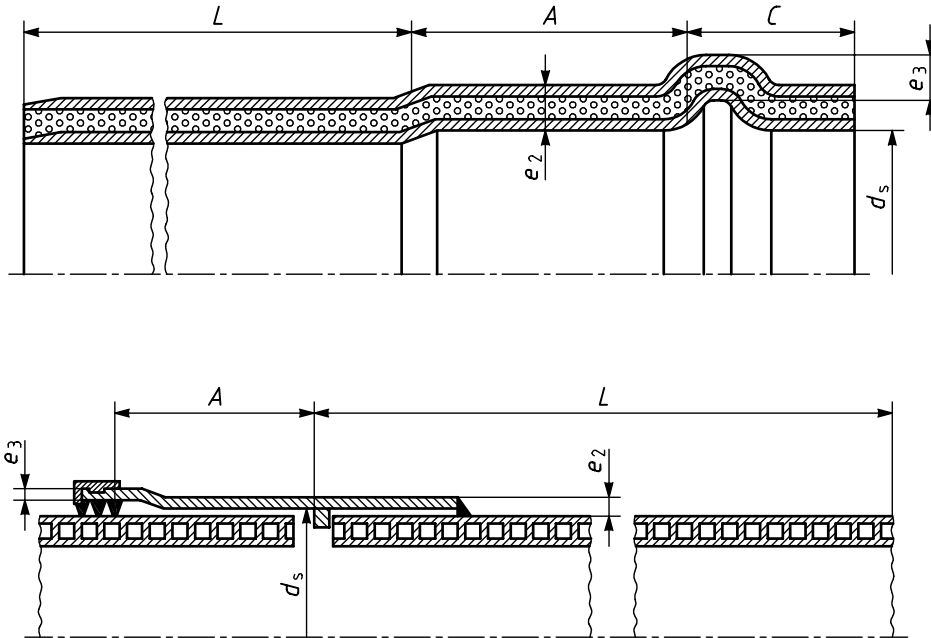

Figure 3 — Typical examples of joints for Type A constructions

5.3 Designation and design of joints

Pipes and fittings may be designed with spigot ends and sockets of another construction than the pipe or fitting body. Such constructions may be Type A1, Type A2 or Type B or solid plain. For definitions and specifications for Type B pipes, see part 3 of this standard.

6 Appearance and colour

The appearance and colour shall conform to EN 13476-1.

7 Geometrical characteristics

7.1 General

All dimensions shall be measured in accordance with EN ISO 3126.

7.2 Dimensions

7.2.1 Designation

Pipes and fittings are sized either according to their outside diameter (DN/OD-series) and/or according to their inside diameter (DN/ID-series).

NOTE Because of the permitted variations in geometric details, conformity to this standard does not ensure interchangeability of pipes, fittings and other components from different manufacturers and/or different designs. Within the same class of tolerances, the Type A1 and solid wall components in accordance with EN 1401-1, EN 1852-1, EN 14758-1 or EN 12666-1, are interchangeable. EN 1852-1, EN 14758-1 and EN 12666-1 include two sets of tolerances on the outside diameters of spigots.

7.2.2 Lengths of pipe

The effective length of the pipe l , shall not be less than that specified by the manufacturer when measured as shown in Figure 3.

7.2.3 Diameters of Type A pipes and Type A spigots of pipes or fittings

The outside diameters and their tolerances are specified in Table 5 and the other dimensions in Table 6.

Outside diameters of Type A pipes and plain spigots for OD series pipes and fittings intended to have jointing dimensions conforming to EN 1401-1, EN 1852-1, EN 14758-1 or EN 12666-1, shall meet the values specified in Table 5.

Other nominal sizes greater than DN/ID 100 and DN/OD 110 and less than DN/OD 1 200 and DN/ID 1 200, than given in Table 5 and Table 6 are permitted. They should preferably be selected from the Renard series R 40 or traditional national dimensions.

In such cases the nominal size DN/ID of pipes and fittings, shall be selected in such a way that the designed minimum mean inside diameter $d_{im,min}$ conforms to the requirement to maximum limit deviations on internal diameters in EN 476.

For DN/ODs and DN/IDs not specified in Table 5 and Table 6, the dimensions shall be linearly interpolated between the adjacent values specified in the tables.

Table 5 — Outside diameters of Type A pipes and plain spigots for OD series pipes and fittings

Nominal size DN/OD	Dimensions in millimetres		
	Mean outside diameter ^a		
	$d_{em,min}$	Close tolerances, CT $d_{em,max}$	Normal tolerances $d_{em,max}$
110	110,0	110,3	111,0
125	125,0	125,3	126,2
160	160,0	160,4	161,5
200	200,0	200,5	201,8
250	250,0	250,5	252,3
315	315,0	315,6	317,9
400	400,0	400,7	403,6
500	500,0	500,9	504,5
630	630,0	631,1	635,7
800	800,0	801,3	807,2
1 000	1 000,0	1 001,6	1 009,0
1 200	1 200,0	1 202,0	1 210,0

^a The CT series is identical to the corresponding tolerances in EN 1401-1.
Plain spigots of PVC-U and spigots used with PVC pipes and fittings shall always conform to the CT series.
Plain spigots of PP or PE shall either conform to the close tolerance or the normal tolerance series. When they have close tolerances they shall be marked "CT".

Table 6 — Nominal sizes, minimum mean inside diameters, thickness of inside layers and socket length

Dimensions in millimetres

Minimum mean inside diameters				Minimum wall thickness			Socket ^a		
DN/OD series		DN/ID series		A1		A2	PVC-U	PP/PE	
DN/OD	PVC-U ^b	PP/ PE ^{b,c}	DN/ID	^c	Multi layer	Hollow wall			
	$d_{im,min}$	$d_{im,min}$		$d_{im,min}$	$e_{4,min}$	$e_{4,min}$	$e_{5,min}$	A_{min}	A_{min}
110	97	90	100	95	0,4	0,6	1,0	32	40
125	107	105			0,4	0,6	1,0	35	43
			125	120			1,0	38	46
160	135	134			0,5	0,8	1,0	42	50
			150	145			1,0	43	51
200	172	167			0,6	1,0	1,1	50	58
			200	195			1,1	54	66
250	216	209	225	220	0,7	1,1	1,4	55	68
			250	245			1,5	59	76
315	270	263			0,8	1,2	1,6	62	81
			300	294			1,7	64	84
400	340	335			1,0	1,5	2,0	70	98
			400	392			2,3	74	106
500	432	418			1,3	2,1	2,8	80	118
			500	490			3,0	85	128
630	540	527			1,6	2,6	3,3	93	144
			600	588			3,5	96	146
800	680	669			2,0	3,0	4,1	110	160
			800	785			4,5	118	168
1 000	864	837			2,5	3,5	5,0	130	180
			1 000	985			5,0	140	190
1 200	1 037	1 005			2,8	4,7	5,0	150	200
			1 200	1 185			5,0	162	212

^a For selection of the A_{min} requirements for a socket, refer to the pipe material and construction. For pipes longer than 6 m it is recommended to produce larger A_{min} than specified in this table.

^b Actual inside diameter of a pipe depends on the material, construction and stiffness. It may be higher than the minimum specified in this table. For more information see the manufacturer's documentation.

^c Minimum mean inside diameter, $d_{sm,min}$, of a fitting shall not be less than 98 % of the specified minimum mean inside diameter of the pipe for which it is designed or conform to this table whichever is the greater value.

7.2.4 Diameters and jointing dimensions of sockets and spigots

Diameters of spigots and jointing dimensions of sockets and spigots shall conform to Table 5 and Table 6.

Minimum and maximum outside diameters of pipes and spigots, $d_{em,min}$ and $d_{em,max}$, and minimum inside diameter of sockets, $d_{sm,min}$, for the preferred sizes are given in Table 7. For sizes other than those given in Table 7, the values shall be calculated using the below mentioned equations.

The minimum inside diameter of sockets, $d_{sm,min}$, shall be equal to $d_{em,max}$.

For pipes and fittings not intended to have jointing dimensions as pipes and/or fittings according to EN 1401-1, EN 1852-1, EN 14758-1 or EN 12666-1 for PVC, PP, PP-MD or PE, the tolerance of the outside diameter of pipe and spigot shall be:

$$d_{em,min} \geq 0,994 \times d_e \quad (1)$$

$$d_{em,max} \leq 1,003 \times d_e \quad (2)$$

where

d_e equals either the nominal size of a DN/OD pipe or the outside diameter as specified by the manufacturer of a DN/ID pipe.

The results are to be rounded to the next highest 0,1 mm.

Table 7 — Outside diameter tolerances and inside diameters of sockets

Dimensions in millimetres

Nominal size DN/OD ^a	Minimum mean outside diameter, $d_{em,min}$	Maximum mean outside diameter, $d_{em,max}$		Minimum mean inside diameter of socket, $d_{sm,min}$	
		close tolerance	normal tolerance	close tolerance	normal tolerance
110	110,0	110,3	111,0	110,3	111,0
125	125,0	125,3	126,2	125,3	126,2
160	160,0	160,4	161,5	160,4	161,5
200	200,0	200,5	201,8	200,5	201,8
250	250,0	250,5	252,3	250,5	252,3
315	315,0	315,6	317,9	315,6	317,9
400	400,0	400,7	403,6	400,7	403,6
500	500,0	500,9	504,5	500,9	504,5
630	630,0	631,1	635,7	631,1	635,7
800	800,0	801,3	807,2	801,3	807,2
1 000	1 000,0	1 001,6	1 009,0	1 001,6	1 009,0
1 200	1 200,0	1 202,0	1 210,0	1 202,0	1 210,0

^a For requirements to other nominal sizes and DN/ID series, use the equations in 7.2.4.

Type A1 and Type A2 sockets and spigots of PVC, PP or PE intended to have jointing dimensions as pipes and fittings conforming to EN 1401-1, EN 1852-1, EN 14758-1 or EN 12666-1, shall conform to one or more of those standards regarding the socket and spigot dimensions, A_{min} , C_{max} , $d_{sm,min}$ and $L_{1,min}$.

In the case where other nominal sizes than specified in those standards are selected for Type A1 and Type A2 pipes and spigots, see 7.2.3.1, the requirements regarding the socket and spigot dimensions, A_{min} , C_{max} , $d_{sm,min}$ and $L_{1,min}$ shall be linearly interpolated between the adjacent values specified in those standards.

7.2.5 Wall thicknesses

7.2.5.1 General

To facilitate easy tracking wall thickness requirements the following information is given:

Wall thickness of pipes	are given in	7.2.5.2
sockets		7.2.5.3
spigots		7.2.5.4
injection moulded fittings		7.2.5.5
fabricated fittings		7.2.5.6
rotational moulded fittings		7.2.5.7

7.2.5.2 Wall thickness of pipes

The wall thickness of the inside layer e_4 (see Figure 1 and Figure 2) and e_5 shall conform to Table 6.

The construction height, e_c , for pipes and spigots of pipes or fittings up to DN/OD 200 and up to 200 mm actual outside diameter of pipes DN/ID series shall be at least as specified for e_{\min} in:

- SDR 41 series in EN 1401-1;
- S 16 series in EN 1852-1;
- SDR 26 series in EN 12666-1;

for PVC-U, PP and PE.

For sizes not specified in those standards, the values shall be linearly interpolated between the adjacent dimensions.

For DN/ID series pipes, the calculation shall be based on the actual outside diameter of the pipes.

7.2.5.3 Wall thickness of sockets

Type A1 and Type A2 sockets and spigots of PVC, PP or PE intended to conform to EN 1401-1, EN 1852-1, EN 14758-1 or EN 12666-1, shall comply with one or more of those standards regarding the socket wall-thickness.

In the case where other nominal sizes than specified in those standards are selected for Type A1 and Type A2 pipes and spigots, see 7.2.3.1, the requirements regarding the socket wall-thickness shall be linearly interpolated between the adjacent values specified in those standards.

When a socket is heat formed on a pipe or pipe segment after extrusion, a maximum reduction of the wall-thicknesses e_4 , e_5 , e_c , as applicable, of 25 % in the sealing ring groove and 15 % in the cylindrical area of the socket is permitted. The base for calculated values is the manufacturer's specified minimum values for the wall-thicknesses.

For other socket designs see EN 13476-3.

7.2.5.4 Wall thickness of spigots

The wall thickness e , of solid plain spigots shall conform to Table 8. The values shall be calculated to the second decimal place and rounded to the next highest 0,1 mm.

Table 8 — Minimum required wall thickness of solid plain spigots.

Material	Outside diameter in mm	Minimum required wall thickness, e_{\min} in mm
PVC-U	$d_e \leq 500$	$d_e/51$, but not less than 3,2
	$d_e > 500$	9,8
PP	$d_e \leq 500$	$d_e/41$, but not less than 3,4
	$d_e > 500$	12,2
PE	$d_e \leq 500$	$d_e/33$, but not less than 4,2
	$d_e > 500$	15,2

Fittings or ancillaries based on Type B and adapted to Type A components shall conform to the minimum dimensions given in EN 13476-3.

7.2.5.5 Wall thickness of injection-moulded fittings

The minimum wall thickness in the body of injection-moulded fittings of Type A1 construction, $e_{4,\min}$, shall conform to the requirements to $e_{4,\min}$ for Type A1 pipes in Table 6.

The construction height of the body wall, e_c , for injection-moulded fittings up to 200 mm, DN/OD and up to 200 mm actual outside diameter of pipes DN/ID series shall be at least as specified for e_{\min} for:

- SDR 41 series in EN 1401-1;
- S 16 series in EN 1852-1;
- SDR 26 series in EN 12666-1;

for PVC-U, PP and PE.

For ID series fittings, the calculation shall be based on the actual outside diameter of the corresponding pipe.

The jointing design shall conform to 7.2.4

The socket and spigot dimensions shall conform to 7.2.5.3 or 7.2.5.4 as appropriate.

7.2.5.6 Wall thickness of fabricated fittings

The wall thickness of the body of fittings fabricated from pipes shall conform to the requirements of the corresponding pipe. Wall thickness reduction due to the process is permitted provided it conforms to the mechanical requirements in Table 17.

The jointing design shall conform to 7.2.4.

The socket and spigot dimensions shall conform to 7.2.5.3 or 7.2.5.4 as applicable.

7.2.5.7 Wall thickness of rotational moulded fittings

The minimum wall thickness in the body of rotational-moulded fittings, $e_{4,\min}$, shall be 1,25 times the values specified for Injection moulded fittings, rounded to the next highest 0,1 mm.

If a rotational moulded fitting has a solid plain spigot and or socket, the minimum required wall-thicknesses e_2 and e_3 as applicable shall be 1,25 times the values derived from 7.2.5.4.

7.3 Types of fittings

The types of fittings covered by this standard are given in EN 13476-1.

7.4 Design length of fittings

The design length of fittings shall conform to with 8.2 of EN 13476-1:2007.

8 Physical characteristics

8.1 Unplasticized poly(vinyl chloride) (PVC-U)

8.1.1 Physical characteristics of PVC-U pipes

When tested in accordance with the test methods as specified in Table 9 using the indicated parameters, the pipe shall have physical characteristics conforming to the requirements given in Table 9.

Table 9 — Physical characteristics of PVC-U pipes

Characteristic	Requirements	Test parameters		Test
Vicat softening temperature (VST) ^a	VST ≥ 79 °C	Shall conform to EN 727		EN 727
Resistance to dichloromethane ^b	No attack	Test temperature	15 °C	EN 580
		Immersion time	30 min	
Longitudinal reversion	≤ 5 % The pipe shall show no delaminations cracks or bubbles ^d	Temperature	(150 ± 2) °C	EN ISO 2505, liquid
		Immersion time ^c for:		
		Or		
		Temperature	(150 ± 2) °C	EN ISO 2505, air
		Heating time ^c for:		

^a Not applicable to the foamed part of a pipe. If e_4 is less than 1,8 mm, the test shall be carried out on a profile extruded from the material. Indirect testing may be carried out using the pipe sample.

^b Only applicable to pipes with a wall thickness $e_4 > 3$ mm. Not applicable to the foamed part of a pipe. Profiles for spirally wound pipes may be tested before winding.

^c For the wall thickness, e , the maximum measured wall thickness of the pipe shall be taken.

^d Bubbles in the foamed structure are exempt from this requirement.

8.1.2 Physical characteristics of PVC-U fittings

When tested in accordance with the test methods as specified in Table 10 using the indicated parameters, the fitting shall have physical characteristics conforming to the requirements given in Table 10.

Table 10 — Physical characteristics of PVC-U injection moulded fittings

Characteristic	Requirements	Test parameters		Test
Vicat softening temperature (VST) ^a	For application UD : VST ≥ 78 °C; U : VST ≥ 77 °C	Shall conform to EN 727		EN 727
Effect of heating ^a	^b	Test temperature Heating time ^c for: $e \leq 3$ mm $3 < e \leq 10$ mm $10 < e \leq 20$ mm	(150 ± 2) °C 15 min 30 min 60 min	EN ISO 580, air
^a Only applicable to injection-moulded fittings and injection-moulded components for fabricated fittings.				
^b				
a) Within a radius of 15 times the wall thickness around the injection point(s), the depth of cracks, delamination or blisters shall not exceed 50 % of the wall thickness at that point.				
b) Within a distance of 10 times the wall thickness from the diaphragm zone, the depth of cracks, delamination or blisters shall not exceed 50 % of the wall thickness at that point.				
c) Within a distance of 10 times the wall thickness from the ring gate the length of cracks running through the overall thickness of the wall shall not exceed 50 % of the wall thickness at that point.				
d) The weld line shall not have opened more than 50 % of the wall thickness at that line.				
e) In all other parts of the surface the depth of cracks and delaminations shall not exceed 30 % of the wall thickness at that point. Blisters shall not exceed a length of 10 times the wall thickness.				
^c For the wall thickness, e , the maximum measured wall thickness of the fitting, excluding e_c shall be taken.				

8.2 Polypropylene (PP)

8.2.1 Physical characteristics of PP pipes

When tested in accordance with the test methods as specified in Table 11 using the indicated parameters, the pipe shall have physical characteristics conforming to the requirements given in Table 11.

Table 11 — Physical characteristics of PP pipes

Characteristic	Requirements	Test parameters		Test method
Longitudinal reversion	≤ 2 %; The pipe shall show no delaminations, cracks or bubbles ^b	Temperature Immersion time ^a for: $e \leq 8$ mm $e > 8$ mm	(150 ± 2) °C 15 min 30 min	EN ISO 2505, liquid
		OR		
		Temperature Heating time ^a for: $e \leq 8$ mm $e > 8$ mm	(150 ± 2) °C 30 min 60 min	EN ISO 2505, air
^a For the wall thickness, e , the maximum measured wall thickness of the pipe shall be taken.				
^b Bubbles in the foamed structure are exempt from this requirement.				

8.2.2 Physical characteristics of PP fittings

When tested in accordance with the test method as specified in Table 12 using the indicated parameters, the fittings shall have physical characteristics conforming to the requirements given in Table 12.

Table 12 — Physical characteristics of PP injection moulded components

Characteristic	Requirements	Test parameters		Test method
Effect of heating ^a	^b	Test temperature Heating time ^c for: $e \leq 3$ mm $3 < e \leq 10$ mm $10 < e \leq 20$ mm	(150 ± 2) °C 15 min 30 min 60 min	EN ISO 580, air
^a Only applicable to injection-moulded fittings and injection-moulded components for fabricated fittings. ^b The depth of cracks, delamination or blisters shall not be more than 20 % of the wall thickness around the injection point(s). No part of the weld line shall open to a depth of more than 20 % of the wall thickness. ^c For the wall thickness, e , the maximum measured wall thickness of the fitting, excluding e_c , shall be taken.				

8.3 Polyethylene (PE)

8.3.1 Physical characteristics of PE pipes

When tested in accordance with the test methods as specified in Table 13 using the indicated parameters, the pipe shall have physical characteristics conforming to the requirements given in Table 13.

Table 13 — Physical characteristics of PE pipes

Characteristic	Requirements	Test parameters		Test method
Longitudinal reversion	≤ 3 %; The pipe shall show no delaminations, cracks or bubbles ^b	Temperature Immersion time ^a for: $e \leq 8$ mm $e > 8$ mm	(110 ± 2) °C 15 min 30 min	EN ISO 2505, liquid
		OR		
		Temperature Heating time ^a for: $e \leq 8$ mm $e > 8$ mm	(110 ± 2) °C 30 min 60 min	EN ISO 2505, air
^a For the wall thickness, e , the maximum measured wall thickness of the pipe shall be taken. ^b Bubbles in the foamed structure are exempt from this requirement.				

8.3.2 Physical characteristics of PE fittings

When tested in accordance with the test method as specified in Table 14 using the indicated parameters, the fitting shall have physical characteristics conforming to the requirements given in Table 14.

Table 14 — Physical characteristics of PE injection moulded components

Characteristic	Requirements	Test parameters		Test
Effect of heating ^a	^b	Test temperature Heating time ^c for: $e \leq 3$ mm $3 < e \leq 10$ mm $10 < e \leq 20$ mm	(110 ± 2) °C 15 min 30 min 60 min	EN ISO 580, air
^a	Only applicable to injection-moulded fittings and injection-moulded components for fabricated fittings.			
^b	The depth of cracks, delamination or blisters shall not be more than 20 % of the wall thickness around the injection point(s). No part of the weld line shall open to a depth of more than 20 % of the wall thickness.			
^c	For the wall thickness, e , the maximum measured wall thickness of the fitting, excluding e_c shall be taken.			

9 Mechanical characteristics

9.1 Mechanical characteristics of pipes

9.1.1 General requirements

When tested in accordance with the test methods as specified in Table 15 using the indicated parameters, the pipe shall have mechanical characteristics conforming to the requirements given in Table 15.

The pipes shall be designated in one of the following nominal ring stiffness classes (SN):

- $DN \leq 500$: SN 4, SN 8 or SN 16;
- $DN > 500$: SN 2, SN 4, SN 8 or SN 16.

For $DN \geq 500$ the manufacturers guaranteed minimum stiffness, between the SN values, of a component may be used for calculation purposes only. Such pipes shall be classified and marked as the next lower stiffness class.

Table 15 — Mechanical characteristics of pipes

Characteristic	Requirements	Test parameters		Test
Ring stiffness	≥ relevant SN	Shall conform to EN ISO 9969		EN ISO 9969
Impact strength at 0 °C (Round the clock method)	TIR ≤ 10 %	Test temperature Conditioning medium Type of striker Mass of striker for : $d_{im,max} \leq 100$ $100 < d_{im,max} \leq 125$ $125 < d_{im,max} \leq 160$ $160 < d_{im,max} \leq 200$ $200 < d_{im,max} \leq 250$ $250 < d_{im,max} \leq 315$ $315 < d_{im,max}$ Fall height of striker for ^b : $d_{em,min} \leq 110$ $d_{em,min} > 110$	(0 ± 1) °C Water or air d90 0,5 kg 0,8 kg 1,0 kg 1,6 kg 2,0 kg 2,5 kg 3,2 kg 1 600 mm 2 000 mm	EN 744
Ring flexibility 30 °C	Shall conform to 9.1.2	Deflection Length of test piece	30 % of d_{em} (300 ± 10) mm	EN 1446
Creep ratio	PVC-U: ≤ 2,5 at 2 years extrapolation. PP and PE: ≤ 4 at 2 years extrapolation	Shall conform to EN ISO 9967		EN ISO 9967
Tensile strength of seam ^d	Shall conform to 9.1.3	Rate of movement	15 mm/min	EN 1979
^a In countries where a less stringent impact resistance test is permitted, Annex G may be applied instead of the impact test at 0 °C (for details see national Foreword). In countries where a more stringent impact resistance test is required, Annex H applies in addition to the impact test at 0 °C (for details see national Foreword). ^b Refer to the specified $d_{em,min}$. ^c In countries where a less stringent ring flexibility test is permitted, Annex I may be applied in stead of the method given in this table (for details see national Foreword). ^d Only applicable to spirally formed pipes.				

9.1.2 Ring flexibility

When tested in accordance with the test method as described in Table 15 using the indicated parameters and visually inspected without magnification, a) and b) shall be conformed to during the test:

- a) there shall be no decrease of the measured force;
- b) there shall be no cracking in any part of the wall structure. For spirally formed pipes, tears initiated along the cut of a rib shall not be considered as a failure if less than $0,075d_{em}$ mm or 75 mm, whichever is smaller; and
- c) to e) shall be conformed to after the test;
- c) there shall be no wall delamination with the exception of possible delamination between the outside and inside wall of double wall pipes occurring in reduced welding zone in the ends of the test piece.
- d) there shall be no other types of rupture in the test piece;
- e) permanent buckling in any part of the structure of the pipe wall, including depressions and craters, shall not occur in any direction.

9.1.3 Tensile strength of seams (Type A.2)

When tested in accordance with Table 15 the minimum required tensile strength of the seam shall conform to Table 16.

Table 16 — Minimum tensile strength of seam

Nominal size DN/ID or DN/OD	Minimum tensile strength N
DN < 400	380
$400 \leq \text{DN} < 600$	510
$600 \leq \text{DN} < 800$	760
DN \geq 800	1 020

9.2 Mechanical characteristics of fittings

The mechanical characteristics of solid-wall fittings are described in the relevant product standards (EN 1401-1, EN 1852-1, or EN 12666-1) or EN 13476-3.

For other fitting designs the following apply:

When tested in accordance with the test methods as specified in Table 17 using the indicated parameters, the fitting shall have mechanical characteristics conforming to the requirements given in Table 17.

The fittings shall be designated in one of the following nominal stiffness classes (SN):

DN \leq 500: SN 4, SN 8 or SN 16;

DN > 500: SN 2, SN 4, SN 8 or SN 16.

For DN \geq 500, the manufacturers guaranteed minimum stiffness, between the SN nominal values of a component, may be used for calculation purposes.

Table 17 — Mechanical characteristics of fittings

Characteristic	Requirements	Test parameters		Test method
Stiffness ^a	≥ relevant SN	Shall conform to ISO 13967		ISO 13967
Impact test	No cracks through the wall; jumped off sealing elements shall be able to be restored into the correct position manually	Test temperature Drop height for: $d_e \leq 125$: $d_e > 125$: Position of impact	0 °C 1 000 mm 500 mm Mouth of the socket	EN 12061
Mechanical strength or flexibility ^b	No signs of splitting, cracking, separation and/or leakage	EITHER		
		Test period Minimum moment for: $d_e \leq 250$ $d_e > 250$	15 min 0,15[DN] ³ × 10 ⁻⁶ kNm 0,01[DN] kNm	EN 12256
		OR		
		Minimum displacement	170 mm	EN 12256
^a	When a fitting according to this standard has the same wall construction as a corresponding pipe, the stiffness of the fitting, because of its geometry, is equal to or greater than that of the pipe. Such fittings can be classified with the same stiffness class as that pipe without testing the stiffness.			
^b	Only for fabricated fittings made from more than one piece (a sealing ring retaining component is not considered as a piece) or when the minimum wall thickness in the body, $e_{4,min}$, is less than $(0,9 \times d_{em}/51)$, $(0,9 \times d_{em}/41)$ (or $0,9 \times d_{em}/33$) for PVC, PP and PE respectively.			

10 Performance Requirements

When tested in accordance with the test methods as specified in Table 18 using the indicated parameters, the joints and the system shall have characteristics conforming to the requirements given in Table 18.

Table 18 — Performance requirements

Characteristic	Requirements	Test parameters		Test method
Tightness of elastomeric ring seal joint		Temperature	(23 ± 2) °C	EN 1277, Condition B
		Spigot deflection	10 %	
		Socket deflection	5 %	
	No leakage	Water pressure	0,05 bar	
Tightness of elastomeric ring seal joint	No leakage	Water pressure	0,5 bar	EN 1277, Condition C
	≤ -0,27 bar	Air pressure	-0,3 bar	
		Temperature	(23 ± 2) °C	
		Joint deflection for:		
	$d_e \leq 315$	2°		
	$315 < d_e \leq 630$	1,5°		
	$630 < d_e$	1°		
Resistance to combined temp. cycling and external Loading ^b	a	For $d_{im} \leq 160$ mm: Shall conform to Method A of EN 1437		Method A of EN 1437 (hot and cold water)
		For $d_{im} > 160$ mm: Shall conform to Method B of EN 1437		Method B of EN 1437 (hot water)
Elevated temperature cycling ^c	No leakage	Shall conform to EN 1055		EN 1055:1996, Figure 2
Long-term performance of TPE seals	Tube pressure: extrapolated 100 years value ≥ 1,5 bar	Test temperature	(23 ± 2) °C	EN 14741
Watertightness ^d	No leakage	Water pressure Duration	0.5 bar 1 min	EN 1053
Tensile test of welded or fused joints	No break in the joint	Minimum tensile force	Shall conform to Table 15	EN 1979 ^e
<p>a The following requirements apply:</p> <ul style="list-style-type: none"> - vertical deformation: ≤ 9 %; - deviation from surface evenness in bottom: ≤ 3 mm; - radius of bottom: ≥ 80 % of original; - opening of weld line: ≤ 20 % of wall thickness; - tightness at 0,35 bar/15 min: No leakage allowed. <p>b Only for components in accordance with this document with DN/OD ≤ 315 and DN/ID ≤ 300 and marked UD.</p> <p>c Only for components in accordance with this document with DN/OD ≤ 200 and DN/ID ≤ 180 and marked UD.</p> <p>d Only for fabricated fittings made from more than one piece. A sealing ring retaining component is not considered as a piece.</p> <p>e This test is applicable for all pipe and fitting constructions when jointed by fusion or welding. The test pieces shall be cut longitudinally in the fusion area. The length of the test piece shall include the joint plus a length at each end sufficient to ensure a proper grip in the tensile testing machine.</p>				

11 Marking

11.1 General

The requirements given in EN 13476-1 apply.

11.2 Minimum required marking

11.2.1 Pipes

Pipes shall be marked at intervals of a maximum of 2 m, at least once per pipe.

The minimum required marking of pipes shall conform to Table 19.

Table 19 — Minimum required marking of pipes

Aspect	Marking or symbols	Legibility ^a
Number of this document	EN 13476-2	a
Diameter series, nominal size/actual guaranteed min. inside diameter ^b for:		
DN/OD series	DN 250 ^c	a
DN/ID series	DN/ID 225 ^c	a
Manufacturer's name and/or trade mark	XXX	a
Stiffness class	e.g. SN 8	a
Ring flexibility	"RF20" (when applicable, see Annex I)	a
Material	Either PVC-U, PVC ^d , PP or PE	a
Application area code	"U" or "UD" as applicable	a
Manufacturer's information	^e	a
Impact resistance – 10 °C	* (ice crystal) (when applicable, see Annex H)	b
Impact resistance + 23 °C	IMP 23 C (when applicable, see Annex G)	b
Close tolerance class ^f	CT	b
^a Legibility codes a denotes durable in use; b denotes legible at least until the system is installed. ^b Marking of the guaranteed minimum mean inside diameter is voluntary, but if marked it shall be as shown. ^c If a component is designed for both DN/OD and DN/ID series, one of them may be marked on a label. ^d PVC-U is preferred to PVC. ^e Shall be given in clear figures or in a code providing traceability to the following details: - production period year and month. - production site if the manufacturer is producing in different sites, nationally and/or internationally. ^f Only applicable for PP and PE pipes with CT spigots as specified in EN 1852-1 or EN 12666-1.		

11.2.2 Fittings

The minimum required marking of fittings shall conform to Table 20.

Table 20 — Minimum required marking of fittings

Aspect	Marking or symbols	Legibility ^a
Number of this document	EN 13476-2	b
Diameter series, nominal size/actual guaranteed min. inside diameter ^b for:		
DN/OD series	DN 200 ^c	a
DN/ID series	DN/ID 200 ^c	a
Manufacturer's name and/or trade mark	xxx	a
Nominal angle	e.g. 45°	b
Stiffness class	e.g. SN 8	b
Material	Either PVC-U ^c , PVC, PP or PE	a
Application area code	"U" or "UD" as applicable	a
Manufacturer's information	e	b
Close tolerance class ^f	CT	b
^a Legibility codes a denotes durable in use; b denotes legible at least until the system is installed. ^b Marking of the guaranteed minimum mean inside diameter is voluntary, but if marked it shall be as shown. ^c If a component is designed for both DN/OD and DN/ID series, one of them may be marked on a label. ^d PVC-U is preferred to PVC. ^e Shall be given in clear figures or in a code providing traceability to the following details: - production period year. - production site if the manufacturer is producing in different sites, nationally and/or internationally. ^f Only applicable for PP and PE fittings with CT spigots as specified in EN 1852-1 or EN 12666-1.		

11.3 Additional marking

11.3.1 General

Pipes and fittings conforming to this standard, which also conform to other standard(s), may be additionally marked with the required marking of that/those other standard(s).

NOTE Attention is drawn to the possible need to include CE marking when required for legislative purposes.

11.3.2 Third party certified pipes and fittings

Pipes and fittings conforming to this standard that are third party certified may be marked accordingly.

Annex A (normative)

Virgin PVC-U material

The virgin material shall be PVC-U to which are added additives needed to facilitate the manufacture of components conforming to the requirements of this standard.

When calculated on the basis of a known formulation or, in case of dispute/not known formulation, determined in accordance with EN 1905, the PVC-U content shall be at least 80 % by mass for pipes and 85 % by mass for injection-moulded fittings;

A further reduction of the PVC-U content for pipes to the following levels:

- Specified intermediate layer of Type A1 pipes : ≥ 60 % by mass;
- Other pipe layers : ≥ 75 % by mass;

is permitted provided the PVC-U is substituted by coated or uncoated CaCO_3 conforming to the following:

1) The composition of the CaCO_3 , before coating if any, shall conform to the following:

- Content of CaCO_3 : ≥ 96 % by mass.
- Content of MgCO_3 : ≤ 4 % by mass.
- Content of CaCO_3 and MgCO_3 in total : ≥ 98 % by mass.

2) The physical properties of the material shall conform to the following:

- Mean particle size, D50 : $\leq 2,5$ μm
- Top cut, D98 : ≤ 20 μm

Annex B (normative)

Utilisation of non-virgin PVC-U material

B.1 Reprocessable and recyclable material from pipes and fittings

NOTE For the purpose of this Annex the term pipes refers to extruded pipes and any parts of a fabricated fitting which is made from an extruded pipe. The term fitting means injection-moulded fittings and injection-moulded parts of a fabricated fitting.

The use of clean, own reprocessable material from components in conformity with this standard for the production of pipes and fittings is permitted without limitations. If fitting material is used for the production of pipes it shall be considered as recyclable material.

B.2 External reprocessable and recyclable materials with agreed specifications

B.2.1 Material from PVC-U pipes and fittings

External reprocessable and recyclable material with an agreed specification from PVC-U pipes and fittings that are available in relevant quantities and intervals of time shall be permitted to be used alone or added to virgin or own reprocessable material or a mixture of those two materials for the production of pipes (and fittings, if relevant), provided that all the conditions specified in 4.1.2 of CEN/TS 14541:2007 are met.

B.2.2 Material from PVC-U products other than pipes and fittings

External reprocessable and recyclable material with an agreed specification from PVC-U products that are available in relevant quantities and intervals of time shall be permitted to be used up to 100 % by mass or added to virgin or own reprocessable material or a mixture of those two materials for the specified intermediate layer of Type A1 pipes under the following conditions:

- a) all of the conditions specified in 4.1.2 of CEN/TS 14541:2007 are met;
- b) all of the additional specifications given in Table B.1 are met.

Table B.1 — Specifications for external reprocessable and recyclable material from PVC-U products other than pipes and fittings

Characteristic	Requirements	Test method
PVC-content	≥ 80 % by mass	EN 1905
K-value	56 ≤ K-value ≤ 70	EN 922
Density	1 390 kg/m ³ ≤ density ≤ 1 500 kg/m ³	EN ISO 1183
Vicat softening temperature (VST)	≥ 62 °C	EN 727
Impurities	≤ 1 500 ppm for particle size ≤ 1 000 μm ≤ 1 500 ppm for 1 000 μm < particle size < 1400 μm	^a
Particle size	> 1 000 μm: maximum 15 % by mass < 1 400 μm: 100 % by mass	sieve analyse
Source of the material	PVC-U products	
^a Based on the source of material and the recycling process, a relevant test method and requirements shall be agreed and stated in the specification. Both the test method and the requirements shall be published.		
NOTE Attention is drawn to possible national regulations regarding heavy metals, e.g. cadmium.		

B.3 External reprocessable and recyclable materials not covered by an agreed specification

B.3.1 Material from PVC-U pipes and fittings

External reprocessable and recyclable material not covered by an agreed specification from PVC-U pipes and fittings that are available in relevant quantities and intervals of time, shall be permitted to be used alone or added to virgin or own reprocessable material or a mixture of those two materials for the production of pipes provided that all of the following conditions are met:

- a) when this material is used the production shall be considered as at least one batch and shall be tested accordingly;
- b) the material shall be clean and dry;
- c) for specified intermediate layers of a pipe of Type A1 up to 100 % by mass of external reprocessable or recyclable material is permitted to be used;
- d) in other cases the maximum allowed amount of reprocessable and recyclable material shall depend on the difference in K-value of the virgin material and the reprocessable and recyclable material as follows:
 - if the difference in K-value, when determined in accordance with EN 922, is ≤ 4 units, then up to 10 % by mass may be added;
 - if the difference in K-value is > 4 units or not determined, then up to 5 % by mass may be added;
- e) quantity of external reprocessable and recyclable materials that is actually added in each production series shall be recorded by the pipe manufacturer.

B.3.2 Material from other PVC-U products than pipes and fittings

External reprocessible and/or recyclable material not covered by an agreed specification from other PVC-U products than pipes and fittings shall not be used for the production of pipes and fittings conforming to this standard.

Annex C (normative)

Virgin PP material

The virgin material shall be PP to which are added additives needed to facilitate the manufacture of components conforming to the requirements of this standard. Coated calcium carbonate (CaCO_3) conforming to a), or talcum conforming to b), may be added as mineral modifiers under the following conditions.

When calculated on the basis of a known formulation or, in case of dispute/not known formulation, determined in accordance with EN ISO 3451-1 the PP content shall be at least 75 % by mass for pipes, 80 % by mass for injection-moulded fittings and 60 % by mass for specified intermediate layer of Type A1 pipes.

a) Specification for CaCO_3 :

1) Composition of the CaCO_3 , before coating, shall conform to the following:

- Content of CaCO_3 ≥ 96 % by mass;
- Content of MgCO_3 ≤ 4 % by mass;
- Content of CaCO_3 and MgCO_3 in total ≥ 98 % by mass.

2) Physical properties of the CaCO_3 shall conform to the following:

- Mean particle size, D50 $\leq 2,5$ μm ;
- Top cut, D98 ≤ 20 μm .

b) Specification for talcum:

1) Content of magnesiumsilicate, $\text{Mg}_3\text{Si}_4\text{O}_{10}(\text{OH})_2$ shall be at least 97 % by mass

2) Physical properties of the talcum shall conform to the following:

- Mean particle size, D50 ≤ 7 μm ;
- Top cut, D98 ≤ 30 μm .

Annex D **(normative)**

Utilisation of non-virgin PP material

D.1 Reprocessable and recyclable material from pipes and fittings

NOTE For the purpose of this Annex, the term pipes refers to extruded pipes and any parts of a fabricated fitting which is made from an extruded pipe. The term fitting means injection-moulded fittings and injection-moulded parts of a fabricated fitting.

The use of clean reprocessable material of components conforming to this standard for the production of pipes and fittings is permitted without limitations.

D.2 External reprocessable and recyclable materials with an agreed specification

D.2.1 Material from PP pipes and fittings

External reprocessable and recyclable materials with an agreed specification from PP from pipes and fittings that are available in relevant quantities and intervals of time may be used alone or added to virgin or own reprocessable or a mixture of those two materials for production of pipes (and fittings, if relevant), provided that all of the conditions specified in 4.1.2 of CEN/TS 14541:2007 are met.

D.2.2 Material from PP products other than pipes and fittings

External reprocessable and/or recyclable material from PP products, other than pipes and fittings, shall not be used for the production of pipes and fittings conforming to this standard.

D.3 External reprocessable and recyclable materials not covered by an agreed specification

D.3.1 Material from PP pipes and fittings.

External reprocessable and recyclable materials not covered by an agreed specification from PP from pipes and fittings shall not be used for the production of pipes and fittings conforming to this standard.

D.3.2 Material from other PP products than pipes and fittings

External reprocessable and/or recyclable material from other PP products than pipes and fittings shall not be used for the production of pipes and fittings conforming to this standard.

Annex E (normative)

Virgin PE material

The virgin material shall be PE to which are added additives needed to facilitate the manufacture of components conforming to the requirements of this standard. Coated calcium carbonate (CaCO_3) conforming to a), or talcum conforming to b), may be added as mineral modifiers under the following conditions.

When calculated on the basis of a known formulation or, in case of dispute/not known formulation, determined in accordance with EN ISO 3451-1, the PE content shall be at least 75 % by mass for pipes, 80 % by mass for injection-moulded fittings and 60 % by mass for specified intermediate layer of Type A1 pipes.

a) Specification for CaCO_3 :

1) composition of the CaCO_3 , before coating, shall conform to the following:

- Content of CaCO_3 ≥ 96 % by mass.
- Content of MgCO_3 ≤ 4 % by mass.
- Content of CaCO_3 and MgCO_3 in total ≥ 98 % by mass.

2) physical properties of the CaCO_3 shall conform to the following:

- Mean particle size, D50 $\leq 2,5$ μm .
- Top cut, D98 ≤ 20 μm .

b) Specification for talcum:

1) content of magnesiumsilicate, $\text{Mg}_3\text{Si}_4\text{O}_{10}(\text{OH})_2$ shall be at least 97 % by mass

2) physical properties of the talcum shall conform to the following:

- Mean particle size, D50 ≤ 7 μm
- Top cut, D98 ≤ 30 μm

Annex F (normative)

Utilisation of non-virgin PE material

F.1 Reprocessable and recyclable material from pipes and fittings

NOTE For the purpose of this annex the term pipes refers to extruded pipes and any parts of a fabricated fitting which is made from an extruded pipe. The term fitting means injection-moulded fittings and injection-moulded parts of a fabricated fitting.

The use of clean own reprocessable material from components complying to this standard for the production of pipes and fittings shall be permitted without limitations.

F.2 External reprocessable and recyclable materials with an agreed specification

F.2.1 Material from PE pipes and injection moulded fittings

External reprocessable and recyclable materials with an agreed specification from PE from pipes and injection moulded fittings that are available in relevant quantities and intervals of time may be used alone or added to virgin or own reprocessable, or a mixture of those two materials for production of pipes (and injection moulded fittings, if relevant) provided all of the conditions specified in 4.1.2 of CEN/TS 14541:2007 are met.

F.2.2 Material from products other than pipes and injection moulded fittings

External reprocessable and/or recyclable material from PE products other than pipes and injection moulded fittings shall not be used for the production of pipes and injection moulded fittings conforming to this standard.

F.3 External reprocessable and recyclable materials not covered by an agreed specification

F.3.1 Material from PE pipes and injection-moulded fittings

External reprocessable and recyclable materials not covered by an agreed specification from PE pipes and injection moulded fittings shall not be used for the production of pipes and injection moulded fittings conforming to this standard.

F.3.2 Material from other PE products than pipes and injection moulded fittings

External reprocessable and/or recyclable material from other PE products than pipes and injection moulded fittings shall not be used for the production of pipes and injection moulded fittings conforming to this standard.

F.4 External reprocessable and recyclable material from PE rotational-moulded fittings and other components

External reprocessable and recyclable materials of PE from:

- rotational moulded fittings covered or not covered by an agreed specification;
- other rotational moulded components covered by an agreed specification.

Those available in relevant quantities and intervals of time shall be permitted to be added to virgin or own reprocessable material for production of rotational moulded fittings provided all of the following conditions are met:

- a) up to 5 % by mass may be used;
- b) when this material is used, the production shall be considered as at least one batch and shall be tested accordingly;
- c) when determined in accordance with EN ISO 1133, the melt mass-flow rate of the material shall not deviate more than 20 % from the value of the virgin material;
- d) when determined in accordance with EN ISO 1183-1 the density of the material shall not be less than the virgin material;
- e) material shall be clean and free from visible contamination;
- f) material of the end product shall conform to the requirements as specified in 4.4 and Annex E;
- g) quantity of reprocessable and/or recyclable material that is actually added shall be recorded by the fitting manufacturer.

Annex G (normative)

Impact test at 23 °C

The impact strength test at 23 °C conforming to this annex may replace the impact strength test at 0 °C (see Table 15) provided it is permitted in the national foreword.

If the national foreword does not permit the impact strength test at 23 °C, this annex shall be considered to be of informative nature for the country concerned.

Pipes tested in accordance with Table G.1 shall conform to the requirement given in this table and shall be marked "IMP 23 C", see Table 19.

Table G.1 — Test parameters and requirements for Impact testing at 23 °C

Characteristic	Requirement	Test parameters		Test method
Impact strength at + 23 °C (round the clock method)	TIR ≤ 10 %	Test temperature	(23 ± 1) °C	EN 744
		Conditioning medium	Water or air	
		Type of striker	d90	
		Mass of striker for:		
		$d_{im,max} \leq 100$	0,5 kg	
		$100 < d_{im,max} \leq 125$	0,8 kg	
		$125 < d_{im,max} \leq 160$	1,0 kg	
		$160 < d_{im,max} \leq 200$	1,6 kg	
		$200 < d_{im,max} \leq 250$	2,0 kg	
		$250 < d_{im,max} \leq 315$	2,5 kg	
		$315 < d_{im,max}$	3,2 kg	
		Fall height of striker for ^a :		
		$d_{em,min} \leq 110$	1 600 mm	
		$d_{em,min} > 110$	2 000 mm	
^a Refer to the specified $d_{em,min}$.				

Annex H (normative)

Impact test at – 10 °C

The impact strength test at -10 °C conforming to this annex may be required as an addition to the impact strength test at 0 °C (see Table 15), provided it is required in the national foreword.

If the national foreword does not require the impact strength test at -10 °C, this annex shall be considered to be of informative nature for the country concerned.

Pipes tested in accordance with Table H.1 shall conform to the requirement given in this table and shall be marked with an ice crystal "❄", see Table 19.

Table H.1 — Mechanical characteristics of pipes

Characteristic	Requirements	Test parameters		Test method
Impact strength at (–10) °C ❄ (Staircase method)	H50 ≥ 1000 mm	Test and conditioning temperature	(– 10 ± 1) °C	EN 1411
	No break below 500 mm	Type of striker	d 90	
		Fall mass for :		
		$d_{em,min} \leq 110$	4,0 kg	
		$110 < d_{em,min} \leq 125$	5,0 kg	
		$125 < d_{em,min} \leq 160$	6,25 kg	
		$160 < d_{em,min} \leq 200$	8,0 kg	
	$200 < d_{em,min} \leq 225$	10,0 kg		
	$225 < d_{em,min}$	12,5 kg		

Annex I (normative)

Ring flexibility test at 20 % diametric deflection

The ring flexibility test at 20 % diametric deflection conforming to this annex may replace the ring flexibility test at 30 % diametric deflection (see Table 15) for DN/ID \geq 300 and DN/OD \geq 400 pipes, installed under conditions "WELL COMPACTION", see Table B.1 of EN 13476-1:2007, provided it is permitted in the national foreword.

If the national foreword does not permit the ring flexibility test at 20 % deflection, this annex shall be considered to be of informative nature for the country concerned.

Pipes tested in accordance with Table I.1 conform to the requirements of this table and shall be marked "RF20", see Table 20.

Table I.1 — Test parameters and requirements for ring flexibility testing at 20 % diametric deflection

Characteristic	Requirements	Test parameters		Test method
Ring flexibility 20 (RF20)	Shall conform to 9.1.2	Deflection Length of test piece Position of test piece	20 % of d_{em} Shall incorporate at least 5 reinforcement ribs. Mould split line, when applicable, at 0°, 45° and 90° from the upper plate	EN 1446

Annex J (informative)

Survey of possible use of reprocessable and recyclable material

A survey of possible use of reprocessable and recyclable material is given in Table J.1.

Table J.1

Material	Description	Reprocessable and recyclable material from pipes and fittings		Reprocessable and recyclable material from non pipes and fittings	
		With agreed specification	Without agreed specification	With agreed specification	Without agreed specification
See subclause		B.2.1	B.3.1	B.2.2	B.3.2
PVC-U	Specified intermediate layer	Up to 100 %	Up to 100 %	Any PVC-U product, up to 100 %	Not permitted
	Other layers	Up to 100 %	5 or 10 %	Not permitted	Not permitted
	Fittings	Up to 100 %	Not permitted	Not permitted	Not permitted
See subclause		D.2.1	D.3.1	D.2.2	D.3.2
PP	Specified intermediate layer	Up to 100 %	Up to 100 %	Not permitted	Not permitted
	Other layers	Up to 100 %	Not permitted	Not permitted	Not permitted
	Fittings	Up to 100 %	Not permitted	Not permitted	Not permitted
See subclause		F.2.1	F.3.1	F.2.2	F.3.2
PE	Specified intermediate layer	Up to 100 %	Up to 100 %	Not permitted	Not permitted
	Other layers	Up to 100 %	Not permitted	Not permitted	Not permitted
	Fittings Injection moulded	Up to 100 %	Not permitted	not permitted	Not permitted
See subclause		F.4	F.4	F.4	F.4
PE	Fittings Rotational moulded	Up to 5%	Up to 5%	Up to 5%	Not permitted
<p>NOTE Experience of recycling of Polyolefines (PP and PE) is for the time being too limited to bring it into an EN. Ongoing work in CEN/TC155/WG25 and the development in recycling technology and experience obtained is expected to make it possible to extend the permitted use of reprocessable and recyclable materials for all three materials in the future.</p> <p>The situation is monitored and considered for the next revision of this standard.</p>					

National Annex NA (informative) to BS EN 13476-2:2007

Additional guidance for UK users

NA.1 Designation of pipes and corresponding fittings

Annex C of BS EN 13476-1 'Designation of pipes and corresponding fittings' gives the requirement options a specifier is responsible for ensuring are identified.

NA.1.1 Initial ring stiffness

BS EN 13476 specifies four nominal ring stiffness classes (SN):

DN ≤ 500: SN 4, SN 8 or SN 16;

DN > 500: SN 2, SN 4, SN 8 or SN 16.

From the viewpoint of installation, SN 8 or SN 4 are the traditionally recommended classes used in the UK for Water Company adopted sewers and are to be used if the system is to be installed in accordance with BS EN 752, BS EN 1610 or BS 5955-6 in order to achieve the intended resistance to long-term deformation.

If it is intended to use SN 2 class of pipe or fitting, the installation should be first subject to a structural design soil load/traffic load calculation and the installation technique modified to suit the results of that calculation.

The appropriate calculation method is given in the National Annex NA (informative) for BS EN 1295-1. The short-term E modulus for the material should be taken from Table A.1 of BS EN 13476-1. The long-term value of E should be taken as the short-term value divided by the creep ratio. The creep ratio is derived from the tests specified in the mechanical characteristics section in BS EN 13476-2 or -3 as appropriate.

NA.1.2 Ring flexibility

Annex I of BS EN 13476-2 and -3 permits a ring flexibility test at 20 % diametric distortion. This is permitted in the UK for diameters greater than 300 mm.

NA.1.3 Impact

Annex G of BS EN 13476-2 and -3 details an impact resistance test at 23 °C. This is the preferred test in the UK in line with the current requirements in WIS 4-35-01.

NA.2 General

NA.2.1 Recycled material

The use of recyclable / reprocessable materials is encouraged in the UK. However, their use should be strictly in accordance with the requirements specified in this standard.

NA.2.2 Interchangeability

The standard does not guarantee interchangeability between manufacturers. It is strongly advised that users specify the bore series of pipes (DN/ID), as specified in BS EN 13476-2 and -3 to maximize the hydraulic performance of these products.

NA.2.3 Colour

For colour, it is the practice of UK sewerage undertakers and installers for the outside layer of structured wall plastic pipes and fittings to be brown in the range 06D45 to 06D43 of BS 4901:1976 to facilitate identification of buried utilities in accordance with the recommendations of the National Joint Utilities Group (NJUG) concerning the colour coding of pipelines and other services.

NA.2.4 Jetting resistance

A requirement for jetting resistance is not included within the standard. A suitable test that is applicable to UK practice is included in WIS 4-35-01.

NA.2.5 Puncture resistance

A requirement for resistance to internal puncture is not included within the standard. A suitable test that is applicable to UK practice is included in WIS 4-35-01.

NA.2.6 Longitudinal bending resistance

No requirement has been given in respect of resistance to longitudinal bending as included in WIS 4-35-01. In the absence of such a requirement it is advised that shorter lengths of pipe than the 6 m allowed by EN 13476 should be specified.

BSI — British Standards Institution

BSI is the independent national body responsible for preparing British Standards. It presents the UK view on standards in Europe and at the international level. It is incorporated by Royal Charter.

Revisions

British Standards are updated by amendment or revision. Users of British Standards should make sure that they possess the latest amendments or editions.

It is the constant aim of BSI to improve the quality of our products and services. We would be grateful if anyone finding an inaccuracy or ambiguity while using this British Standard would inform the Secretary of the technical committee responsible, the identity of which can be found on the inside front cover.
Tel: +44 (0)20 8996 9000. Fax: +44 (0)20 8996 7400.

BSI offers members an individual updating service called PLUS which ensures that subscribers automatically receive the latest editions of standards.

Buying standards

Orders for all BSI, international and foreign standards publications should be addressed to Customer Services. Tel: +44 (0)20 8996 9001.
Fax: +44 (0)20 8996 7001. Email: orders@bsi-global.com. Standards are also available from the BSI website at <http://www.bsi-global.com>.

In response to orders for international standards, it is BSI policy to supply the BSI implementation of those that have been published as British Standards, unless otherwise requested.

Information on standards

BSI provides a wide range of information on national, European and international standards through its Library and its Technical Help to Exporters Service. Various BSI electronic information services are also available which give details on all its products and services. Contact the Information Centre.
Tel: +44 (0)20 8996 7111. Fax: +44 (0)20 8996 7048. Email: info@bsi-global.com.

Subscribing members of BSI are kept up to date with standards developments and receive substantial discounts on the purchase price of standards. For details of these and other benefits contact Membership Administration.
Tel: +44 (0)20 8996 7002. Fax: +44 (0)20 8996 7001.
Email: membership@bsi-global.com.

Information regarding online access to British Standards via British Standards Online can be found at <http://www.bsi-global.com/bsonline>.

Further information about BSI is available on the BSI website at <http://www.bsi-global.com>.

Copyright

Copyright subsists in all BSI publications. BSI also holds the copyright, in the UK, of the publications of the international standardization bodies. Except as permitted under the Copyright, Designs and Patents Act 1988 no extract may be reproduced, stored in a retrieval system or transmitted in any form or by any means – electronic, photocopying, recording or otherwise – without prior written permission from BSI.

This does not preclude the free use, in the course of implementing the standard, of necessary details such as symbols, and size, type or grade designations. If these details are to be used for any other purpose than implementation then the prior written permission of BSI must be obtained.

Details and advice can be obtained from the Copyright & Licensing Manager.
Tel: +44 (0)20 8996 7070. Fax: +44 (0)20 8996 7553.
Email: copyright@bsi-global.com.