

Cryogenic vessels — Static vacuum insulated vessels —

Part 2: Design, fabrication, inspection and testing

The European Standard EN 13458-2:2002 has the status of a
British Standard

ICS 23.020.40

National foreword

This British Standard is the official English language version of EN 13458-2:2002.

The UK participation in its preparation was entrusted to Technical Committee PVE/18, Cryogenic vessels, which has the responsibility to:

- aid enquirers to understand the text;
- present to the responsible international/European committee any enquiries on the interpretation, or proposals for change, and keep the UK interests informed;
- monitor related international and European developments and promulgate them in the UK.

A list of organizations represented on this committee can be obtained on request to its secretary.

Cross-references

The British Standards which implement international or European publications referred to in this document may be found in the *BSI Catalogue* under the section entitled “International Standards Correspondence Index”, or by using the “Search” facility of the *BSI Electronic Catalogue* or of British Standards Online.

This publication does not purport to include all the necessary provisions of a contract. Users are responsible for its correct application.

Compliance with a British Standard does not of itself confer immunity from legal obligations.

This British Standard, having been prepared under the direction of the Engineering Sector Policy and Strategy Committee, was published under the authority of the Standards Policy and Strategy Committee on 29 November 2002

Summary of pages

This document comprises a front cover, an inside front cover, the EN title page, pages 2 to 107 and a back cover.

The BSI copyright date displayed in this document indicates when the document was last issued.

Amendments issued since publication

Amd. No.	Date	Comments

ICS 23.020.40

English version

Cryogenic vessels - Static vacuum insulated vessels - Part 2: Design, fabrication, inspection and testing

Réceptacles cryogéniques - Réceptacles fixes isolés sous vide
- Partie 2: Conception, fabrication, inspection et essais

Kryo-Behälter - Ortsfeste vakuum-isolierte Behälter - Teil 2:
Bemessung, Herstellung und Prüfung

This European Standard was approved by CEN on 12 August 2002.

CEN members are bound to comply with the CEN/CENELEC Internal Regulations which stipulate the conditions for giving this European Standard the status of a national standard without any alteration. Up-to-date lists and bibliographical references concerning such national standards may be obtained on application to the Management Centre or to any CEN member.

This European Standard exists in three official versions (English, French, German). A version in any other language made by translation under the responsibility of a CEN member into its own language and notified to the Management Centre has the same status as the official versions.

CEN members are the national standards bodies of Austria, Belgium, Czech Republic, Denmark, Finland, France, Germany, Greece, Iceland, Ireland, Italy, Luxembourg, Malta, Netherlands, Norway, Portugal, Spain, Sweden, Switzerland and United Kingdom.



EUROPEAN COMMITTEE FOR STANDARDIZATION
COMITÉ EUROPÉEN DE NORMALISATION
EUROPÄISCHES KOMITEE FÜR NORMUNG

Management Centre: rue de Stassart, 36 B-1050 Brussels

Contents

	page
Foreword	3
1 Scope	4
2 Normative references	4
3 Terms, definitions and symbols	6
4 Design	8
5 Fabrication	54
6 Inspection and testing	61
Annex A (normative) Elastic stress analysis	68
Annex B (normative) Additional requirements for 9 % Ni steel	77
Annex C (informative) Pressure strengthening of vessels from austenitic stainless steels	79
Annex D (normative) Pressure limiting systems	90
Annex E (normative) Further use of the material cold properties to resist pressure loads	91
Annex F (informative) Specific weld details	95
Annex G (normative) Additional requirements for flammable fluids	99
Annex H (informative) Non-design requirements for flammable fluids	100
Annex I (normative) Outer jacket relief devices	101
Annex J (informative) Increased material property for austenitic stainless steel	103
Annex K (normative) Base materials	104
Annex L (informative) Other materials	105
Annex ZA (informative) Clauses of this European Standard addressing essential requirements or other provisions of EU directives	106
Bibliography	107

Foreword

This document (EN 13458-2:2002) has been prepared by Technical Committee CEN/TC 268 "Cryogenic vessels", the secretariat of which is held by AFNOR.

This European Standard shall be given the status of a national standard, either by publication of an identical text or by endorsement, at the latest by May 2003, and conflicting national standards shall be withdrawn at the latest by May 2003.

This document has been prepared under a mandate given to CEN by the European Commission and the European Free Trade Association, and supports essential requirements of EU Directive(s).

For relationship with EU Directive(s), see informative Annex ZA, which is an integral part of this document.

In this European Standard the annexes A, B E, G, I and K are normative and the annexes C, D, F, H and J are informative.

EN 13458 consists of the following Parts under the general title, *Cryogenic vessels – Static vacuum insulated vessels*

- *Part 1: Fundamental requirements*
- *Part 2: Design, fabrication, inspection and testing*
- *Part 3: Operational requirements*

According to the CEN/CENELEC Internal Regulations, the national standards organizations of the following countries are bound to implement this European Standard: Austria, Belgium, Czech Republic, Denmark, Finland, France, Germany, Greece, Iceland, Ireland, Italy, Luxembourg, Malta, Netherlands, Norway, Portugal, Spain, Sweden, Switzerland and the United Kingdom.

1 Scope

This European Standard specifies requirements for the design, fabrication, inspection and testing of static vacuum insulated cryogenic vessels designed for a maximum allowable pressure of more than 0,5 bar.

This European Standard is applicable to static vacuum insulated cryogenic vessels for fluids as specified in EN 13458-1, and does not apply to vessels designed for toxic fluids.

For static vacuum insulated cryogenic vessels designed for a maximum allowable pressure of not more than 0,5 bar this standard can be used as a guide.

2 Normative references

This European Standard incorporates by dated or undated reference, provisions from other publications. These normative references are cited at the appropriate places in the text, and the publications are listed hereafter. For dated references, subsequent amendments to or revisions of any of these publications apply to this European Standard only when incorporated in it by amendment or revision. For undated references the latest edition of the publication referred to applies (including amendments).

EN 287-1, *Approval testing of welders – Fusion welding – Part 1: Steels.*

EN 287-2, *Approval testing of welders – Fusion welding – Part 2: Aluminium and aluminium alloys.*

EN 288-3:1992, *Specification and approval of welding procedures for metallic materials – Part 3: Welding procedure tests for the arc welding of steels.*

EN 288-4:1992, *Specification and approval of welding procedures for metallic materials – Part 4: Welding procedure tests for the arc welding of aluminium and its alloys.*

EN 288-8, *Specification and approval of welding procedures for metallic materials – Part 8: Approval by a pre-production welding test.*

EN 473, *Qualification and certification of NDT personnel – General principles.*

EN 875:1995, *Destructive tests on welds in metallic materials – Impact tests – Test specimen location, notch orientation and examination.*

EN 895:1995, *Destructive tests on welds in metallic materials – Transverse tensile test.*

EN 910:1996, *Destructive tests on welds in metallic materials – Bend tests.*

EN 1252-1:1998, *Cryogenic vessels – Materials – Part 1: Toughness requirements for temperatures below –80 °C.*

EN 1252-2, *Cryogenic vessels – Materials – Part 2: Toughness requirements for temperatures between –80 °C and –20 °C.*

EN 1418, *Welding personnel – Approval testing of welding operators for fusion welding and resistance weld setters for fully mechanised and automatic welding of metallic materials.*

EN 1435, *Non-destructive examination of welds – Radiographic examination of welded joints.*

EN 1626, *Cryogenic vessels – Valves for cryogenic service.*

EN 1797, *Cryogenic vessels – Gas/material compatibility.*

EN 10028-4, *Flat products made of steels for pressure purposes – Part 4: Nickel alloy steels with specified low temperature properties.*

EN 10028-7:2000, *Flat products made of steels for pressure purposes – Part 7: Stainless steels.*

prEN 10216-5, *Seamless steel tubes for pressure purposes - Technical delivery conditions - Part 5: Stainless steel tubes.*

prEN 10217-7, *Welded steel tubes for pressure purposes - Technical delivery conditions - Part 7: Stainless steel tubes.*

EN 12300, *Cryogenic vessels – Cleanliness for cryogenic service.*

EN 13068-3, *Non-destructive testing – Radioscopic testing – Part 3: General principles of radioscopic testing of metallic materials by X- and gamma rays.*

EN 13133, *Brazing – Brazer approval.*

EN 13134, *Brazing – Procedure approval.*

EN 13445-3, *Unfired pressure vessels – Part 3: Design.*

EN 13445-4, *Unfired pressure vessels – Part 4: Fabrication.*

EN 13458-1:2002, *Cryogenic vessels – Static vacuum insulated vessels - Part 1: Fundamental requirements.*

prEN 13458-3, *Cryogenic vessels – Static vacuum insulated vessels – Part 3: Operational requirements.*

prEN 13648-1, *Cryogenic vessels – Safety devices for protection against excessive pressure – Part 1: Fundamental requirements*

prEN 13648-3, *Cryogenic vessels – Safety devices for protection against excessive pressure – Part 3: Determination of required discharge – Capacity and sizing.*

prEN ISO 4126-2, *Safety devices for protection against excessive pressure – Part 2: Bursting disc safety devices (ISO/DIS 4126-2:1996).*

EN ISO 6520-1:1998, *Welding and allied processes – Classification of geometrical imperfections in metallic materials – Part 1: Fusion welding (ISO 6520-1:1998).*

ISO 1106-1, *Recommended practice for radiographic examination of fusion welded joints - Part 1: Fusion welded butt joints in steel plates up to 50 mm thick.*

SA-353/A353M, *Specification for pressure vessel plates, alloy steel, 9 percent nickel, double-normalized and tempered.*

SA-479/SA-479M, *Specification for stainless steel bars and shapes for use in boilers and other pressure vessels.*

SA-522/SA-522M, *Specification for forged or rolled 8 and 9% nickel alloy steel flanges, fittings, valves and parts for low-temperature service.*

SA-553/SA-553M, *Specification for pressure vessel plates, alloy steel quenched and tempered 8 and 9 percent nickel.*

3 Terms, definitions and symbols

3.1 Terms and definitions

For the purposes of this European Standard, the following terms and definitions apply.

3.1.1

static vessel

stationary unit capable of receiving, storing (under pressure) and dispensing cryogenic fluids. The vessel is not intended to be used for transporting liquid product

3.1.2

inner vessel

pressure vessel proper intended to contain the cryogenic fluid

3.1.3

outer jacket

gas-tight enclosure which contains the inner vessel and enables a vacuum to be established

3.1.4

automatic welding

welding in which the parameters are automatically controlled. Some of these parameters may be adjusted to a limited extent, either manually or automatically, during welding to maintain the specified welding conditions

3.1.5

maximum allowable pressure, p_s

maximum pressure for which the equipment is designed, as specified by the manufacturer, defined at a location specified by the manufacturer, being the location of connection of protective or limiting devices or the top of the equipment

NOTE p_s is equivalent to PS used in article 1, 2.3 of the PED.

3.1.6

relief plate/plug

plate or plug retained by atmospheric pressure only which allows relief of excess internal pressure

3.1.7

bursting disc device

non-reclosing pressure relief device ruptured by differential pressure. It is the complete assembly of installed components including where appropriate the bursting disc holder

3.2 Symbols

NOTE Throughout this European Standard p_s is equivalent to PS used in article 1, 2.3 of the PED and p_T is equivalent to PT used in Annex I of the PED.

For the purposes of this standard, the following symbols apply:

c	allowances	mm
d_i	diameter of opening	mm
d_a	outside diameter of tube or nozzle	mm
f	narrow side of rectangular or elliptical plate	mm
l_b	buckling length	mm

n	number	-
p	design pressure as defined by 4.2.3.2 j) and 4.3.3.2	bar
p_e	allowable external pressure limited by elastic buckling	bar
p_k	strengthening pressure	bar
p_p	allowable external pressure limited by plastic deformation	bar
p_T	pressure test (see 4.2.3.2 g))	bar
r	radius e.g. inside knuckle radius of dished end and cones	mm
s	minimum wall thickness	mm
s_e	actual wall thickness	mm
v	factor indicative of the utilisation of the permissible design stress in joints or factor allowing for weakenings	-
x	(decay-length zone) distance over which governing stress is assumed to act	mm
A	area	mm ²
A_5	elongation at fracture	
C	design factors	-
D	shell diameter	mm
D_a	outside diameter e.g. of a cylindrical shell	mm
D_i	internal diameter e.g. of a cylindrical shell	mm
E	Young's modulus	N/mm ²
I	moment of inertia of stiffening ring	mm ⁴
K	material property (see 4.3.2.3.1)	N/mm ²
K_{20}	see 4.3.2.3.2	
K_t	see 4.3.2.3.3	
K_{design}	a value defined by the manufacturer for a particular design case	
R	radius of curvature e.g. inside crown radius of dished end	mm
S	safety factor at design pressure	-
S_k	safety factor against elastic buckling at design pressure	-
S_p	safety factor against plastic deformation at design pressure	-
S_T	safety factor against plastic deformation at proof test pressure	-

Z	auxiliary value	-
ν	Poisson's ratio	-
u	out of roundness	
σ_k	design stress value	N/mm ²

4 Design

4.1 Design options

4.1.1 General

The design shall be carried out in accordance with one of the options given in 4.1.2, 4.1.3 or 4.1.4.

In the case of 9 % Ni steel, the additional requirements of annex B shall be satisfied.

For carbon and low alloy steels the requirements of EN 1252-2 shall be satisfied.

When further use of cold properties is considered the requirements of annex E shall be satisfied.

4.1.2 Design by calculation

Calculation of all pressure and load bearing components shall be carried out. The pressure part thicknesses of the inner vessel and outer jacket shall not be less than required by 4.3. Additional calculations may be required to ensure the design is satisfactory for the operating conditions including an allowance for external loads (e.g. seismic).

4.1.3 Design by calculation when adopting pressure strengthening

The pressure retaining capability of inner vessels manufactured from austenitic stainless steel, strengthened by pressure, is calculated in accordance with the informative annex C.

4.1.4 Design by calculation supplemented with experimental methods

Where it is not possible to design by calculation alone planned and controlled experimental means may be used providing that the results confirm the standards of design required in 4.3. An example would be the application of strain gauges to assess stress levels.

4.2 Common design requirements

4.2.1 General

The requirements of 4.2.2 to 4.2.8 are applicable to all vessels irrespective of the design option used.

In the event of an increase in at least one of the following parameters:

- maximum allowable pressure;
- specific mass (density) of the densest gas for which the vessel is designed;
- maximum tare weight of the inner vessel;
- nominal length and/or diameter of the inner shell;

or, in the event of any change relative:

- to the type of material or grade (e.g. stainless steel to aluminium or change of stainless steel grade);
- to the fundamental shape;
- to the decrease in the minimum properties of material being used;
- to the modification of the design of an assembly method concerning any part under stress, particularly as far as the support systems between the inner vessel and the outer jacket or the inner vessel itself or the protective frame, if any, are concerned;

the initial design programme shall be repeated to take account of these modifications.

4.2.2 Design specification and documentation

To enable the design to be prepared the following information shall be available:

- maximum allowable pressure;
- fluids intended to be used;
- liquid capacity;
- volume of the inner vessel;
- configuration;
- method of handling and securing during transit and site erection;
- site conditions e.g. ambient temperatures, seismic etc.;
- fill and withdrawal rates.

A design document in the form of drawings with text if any shall be prepared, it shall contain the information given above plus the following where applicable:

- definition of which components are designed by calculation, by pressure strengthening, by experiment and by satisfactory in-service experience;
- drawings with dimensions and thicknesses of load bearing components;
- specification of all load bearing materials including grade, class, temper, testing etc. as relevant;
- type of material test certificates;
- location and details of welds and other joints, welding and other joining procedures, filler, joining materials etc. as relevant;
- calculations to verify compliance with this standard;
- design test programme;
- non destructive testing requirements;
- pressure test requirements;
- piping configuration including type, size and location of all valves and relief devices;

- details of lifting points and lifting procedure;
- wind, seismic loads.

4.2.3 Design loads

4.2.3.1 General

Static vessels are not considered to be in cyclic service, therefore fatigue analysis needs normally not to be performed.

The static cryogenic vessel shall be able to safely withstand the mechanical and thermal loads encountered during normal operation and pressure test, as specified in 4.2.3.2 to 4.2.3.7.

4.2.3.2 Inner vessel

The following loads shall be considered to act in the combinations specified in 4.2.3.2 j):

- a) pressure during operation when the vessel contains cryogenic liquid product

$$p_{cL} = p_s + p_L + 1 \text{ bar}$$

where

p_s maximum allowable pressure (in bar);

p_L pressure (in bar) exerted by the weight of the liquid contents when the vessel is filled to capacity with either:

- 1) boiling liquid at atmospheric pressure; or
- 2) cryogenic fluid at its equilibrium triple point or melting point temperature at atmospheric pressure.

p_L may be neglected if less than 5 % of $(p_s + 1)$. Otherwise the pressure in excess of 5 % of $(p_s + 1)$ shall be used;

- b) pressure during operation when the vessel contains only gaseous product at 20 °C

$$p_{cG} = p_s + 1 \text{ bar}$$

- c) reactions at the support points of the inner vessel during operation when the vessel contains cryogenic liquid product. The reactions shall be determined by the weight of the inner vessel, the weight of the maximum contents of the cryogenic liquid and vapour and seismic loadings where appropriate. The seismic loadings shall consider any forces exerted on the vessel by the insulation;
- d) reactions at the support points of the inner vessel during operation when the vessel contains only gaseous product at 20 °C. The reactions shall be determined by the weight of the inner vessel, its contents and seismic loadings where appropriate. The seismic loadings shall consider any forces exerted on the vessel by the insulation;
- e) load imposed by the piping due to the differential thermal movement of the inner vessel, the piping and the outer jacket.

The following cases shall be considered:

- cool down (inner vessel warm - piping cold);
- filling and withdrawal (inner vessel cold - piping cold); and

— storage (inner vessel cold - piping warm);

f) load imposed on the inner vessel at its support points when cooling from ambient to operating temperature.

g) pressure test : the value used for design purposes shall be the higher of:

$$p_T = 1,43 (p_s + 1) \text{ or see 6.5.1 or}$$

$$p_T = 1,25 (p_s + p_L + 1) \frac{K_{20}}{K_{design}} \text{bar}$$

considered for each element of the vessel e.g. shell, courses, head, etc.

The 1 bar is added to allow for the external vacuum;

h) loads imposed during transit and site erection;

i) load imposed by pressure in annular space equal to the set pressure of the outer jacket relief device and atmospheric pressure in inner vessel;

j) the vessel shall be capable of withstanding the following combinations of loadings. The design pressure p is equal to pressure specified therein, in each combination 1, 2 and 3:

1) operation at maximum allowable working pressure when vessel is filled with cryogenic liquid:
a) + c) + e) + f);

2) operation at maximum allowable working pressure when vessel is filled with warm gas: b) + d);

3) pressure test: g);

4) shipping and lifting: h);

5) vessel subject to external pressure developed in the vacuum jacket: i).

The inner vessel shall, in addition, be capable of holding the pressure test fluid without gross plastic deformation.

4.2.3.3 Outer jacket

The following loads shall be considered to act in combination where relevant:

a) an external pressure of 1 bar;

b) an internal pressure equal to the set pressure of the outer jacket pressure relief device;

c) load imposed by the supporting systems in the outer jacket taking into consideration site conditions, e.g. wind and seismic loadings etc.;

d) load imposed by piping as defined in 4.2.3.2 e);

e) load imposed at the inner vessel support points in the outer jacket when the inner vessel cools from ambient to operating temperature and during operation;

f) loads imposed during transit and site erection;

g) external loads from e.g. wind, seismic or other site conditions;

h) gross mass.

4.2.3.4 Inner vessel supports

The inner vessel supports shall be suitable for the load defined in 4.2.3.2 c) plus loads due to differential thermal movements.

4.2.3.5 Outer jacket supports

The outer jacket supports shall be suitable for the load defined in 4.2.3.3.

4.2.3.6 Lifting points

Lifting points shall be suitable for lifting the static cryogenic vessel when empty and lifted in accordance with the specified procedure.

4.2.3.7 Piping and accessories

Piping including valves, fittings and supports shall be designed for the following loads. With the exception a) the loads shall be considered to act in combination where relevant:

- a) pressure test : in accordance with 6.5.4;
- b) pressure during operation : not less than the set pressure of the system pressure relief devices, e.g. set pressure of the thermal relief device;
- c) thermal loads defined in 4.2.3.2 e);
- d) loads generated during pressure relief discharge;
- e) a design pressure not less than the maximum allowable pressure p_s of the inner vessel plus any appropriate liquid head. For piping inside the vacuum jacket a further 1 bar shall be added.

4.2.4 Corrosion allowance

Corrosion allowance is not required on surfaces in contact with the operating fluid. Corrosion allowance is not required on other surfaces if they are adequately protected against corrosion.

4.2.5 Inspection openings

Inspection openings are not required in the inner vessel or the outer jacket, providing the requirements of prEN 13458-3 are followed.

NOTE 1 Due to the combination of materials of construction and operating fluids, internal corrosion cannot occur.

NOTE 2 The inner vessel is inside the evacuated outer jacket and hence external corrosion of the inner vessel cannot occur.

NOTE 3 The elimination of inspection openings also assists in maintaining the integrity of the vacuum in the interspace.

4.2.6 Pressure relief

4.2.6.1 General

Relief devices for the inner vessel shall be in accordance with prEN 13648-1.

Relief devices for the outer jacket shall be in accordance with annex I.

4.2.6.2 Inner vessel

The inner vessel shall be provided with a pressure limiting system to protect the vessel against excessive pressure. Examples of current practice are shown in annex D. The system shall:

- be designed so that it is fit for purpose;
- be independent of other functions, unless its safety function is not affected by such other functions;
- limit the vessel pressure to 110 % maximum allowable pressure in a momentary surge;
- fail safely;
- contain redundant features;
- contain non-common mode failure mechanisms (diversity).

The capacity of the protection system shall be established by considering all of the probable conditions contributing towards internal excess pressure. For example:

- a) normal vessel heat leak;
- b) heat leak with loss of vacuum;
- c) failure in the open position of the make-up pressure control valve;
- d) any other valve in a line connecting a high pressure source to the inner vessel;
- e) recycling of any possible combination of pumps;
- f) flash gas, plus liquid, from maximum plant capacity fed into a tank which is at operating temperature.

The excess pressure created by any combination of conditions 'a' to 'f' shall be limited to not more than 110 % of maximum allowable pressure by at least one re-closable device. The required capacity of this re-closable device may be calculated in accordance with prEN 13648-3.

NOTE Where, in addition, a non re-closable, fail open device is fitted, its operating pressure should be chosen such that its ability to retain pressure is unaffected by the operation of the re-closable device at 110 % of maximum allowable pressure and is, in any case, not more than the top of vessel strength test pressure less 1 bar. The required capacity of any device provided for redundancy should be equal to the required capacity of the primary device.

An external fire condition only to be considered if determined by location of the cryogenic vessel.

Shut off valves or equivalent may be installed upstream of pressure relief devices, provided that interlocks are fitted to ensure that the vessel has sufficient relief capacity at all times.

The relief valve system piping shall be sized such that the pressure drops during discharge are fully taken into account so that the vessel pressure is not excessive and also that the valve does not reseat instantly, i.e. chatter.

The maximum pressure drop of the pipework to the pressure relief valve should not exceed that specified in prEN 13648-3.

4.2.6.3 Outer jacket

A pressure relief device shall be fitted to the outer jacket. The device shall be set to open at a pressure which prevents collapse of the inner vessel and is not more than 0,5 bar. The discharge area of the pressure relief device shall be not less than 0,34 mm²/l capacity of the inner vessel and in any case need not exceed 5 000 mm².

4.2.6.4 Piping

Any section of pipework containing cryogenic fluid which can be isolated shall be protected by a relief valve or other suitable relief device.

4.2.7 Valves

4.2.7.1 General

Valves shall conform to EN 1626.

4.2.7.2 Isolating valves

To prevent any large spillage of liquid, a secondary means of isolation shall be provided for those lines emanating from below the liquid level that are:

- greater than 9 mm bore and exhausting to atmosphere; or
- greater than 50 mm bore when forming part of a closed system.

The secondary means of isolation may be within the user installation and shall provide an equivalent level of protection.

The secondary means of isolation, where provided, may be achieved, for example, by the installation of a second valve, positioned so that it can be operated safely in emergency, an automatic fail-closed valve or a non-return valve or fixed or removable cap on the open end of the pipe.

4.2.8 Filling ratio

Means shall be provided to ensure that the vessel is not filled to more than 98 % of its total volume with liquid at the filling condition.

4.3 Design by calculation

4.3.1 General

When design is by calculation in accordance with 4.1.2, the dimensions of the inner vessel and outer jacket shall not be less than that determined in accordance with this subclause.

4.3.2 Inner vessel

4.3.2.1 General

The information in 4.3.2.2 to 4.3.2.6 shall be used to determine the pressure part thicknesses in conjunction with the calculation formulae of 4.3.6.

4.3.2.2 Design loads and allowable stresses

- a) In accordance with 4.2.3.2 j) 1)

Material properties determined either in accordance with 4.3.2.3.2 or 4.3.2.3.3 shall be adopted at the discretion of the vessel manufacturer.

- b) In accordance with 4.2.3.2 j) 2), 3), 4) and 5)

Material properties determined in accordance with 4.3.2.3.2 shall be adopted.

4.3.2.3 Material property K

4.3.2.3.1 General

The material property K to be used in the calculations shall be as follows:

- for austenitic stainless steel and unalloyed aluminium, 1 % proof strength;
- for all other metals the yield strength, and if not available 0,2 % proof strength.

NOTE Upper yield strength can be used.

4.3.2.3.2 K_{20}

K shall be the minimum value at 20 °C taken from the material standard, (see annex J).

4.3.2.3.3 K_t

The permissible value of K shall be determined for the material at the operating temperature corresponding to the saturation temperature at the maximum allowable pressure of the vessel, of the contained cryogenic fluid. The value of K and E shall be determined from the material standard (see EN 10028-7:2000, annex F for austenitic stainless steels) or shall be guaranteed by the material manufacturer.

4.3.2.4 Safety factors S , S_T , S_p and S_k

Safety factors are the ratio of material property K over the maximum allowable stress.

a) internal pressure (pressure on the concave surface):

- at vessel maximum allowable pressure

$$S = 1,5$$

- at vessel proof test pressure

$$S_T = 1,05$$

b) external pressure (pressure on the convex surface):

- cylinders and cones $S_p = 1,6$

$$S_k = 3,0$$

- spherical region $S_p = 2,4$

$$S_k = 3,0 + 0,002 R/s$$

- knuckle region $S_p = 1,8$

4.3.2.5 Weld joint factors v

For internal pressure (pressure on the concave surface) $v = 0,85$ or $1,0$ (see clause 6, Table 6).

For external pressure (pressure on the convex surface) $v = 1,0$.

4.3.2.6 Allowances c

$$c = 0$$

4.3.3 Outer jacket

4.3.3.1 General

The following shall be used to determine the pressure part thicknesses in conjunction with the calculation formulae of 4.3.6.

4.3.3.2 Design pressure p

The internal design pressure p shall be equal to the set pressure of the outer jacket pressure relief device.

The external design pressure p shall be 1 bar.

4.3.3.3 Material property K

The material property K to be used in the calculations shall be at 20 °C, as defined in 4.3.2.3.

4.3.3.4 Safety factors S , S_p and S_k

Internal pressure (pressure on the concave surface)

$$S = 1,1$$

External pressure (pressure on the convex surface)

— cylinders and cones $S_p = 1,1$

$$S_k = 2,0^*)$$

— spherical region $S_p = 1,6$

$$S_k = 2,0 + 0,001\ 4\ R/s$$

— knuckle region $S_p = 1,2$

4.3.3.5 Weld joint factors v

For internal pressure (pressure on the concave surface) $v = 0,7$.

For external pressure (pressure on the convex surface) $v = 1,0$.

*) For well proven designs a factor of safety S_k equal to 1,5 is acceptable provided that :

D is not more than 2 300 mm ;

l_b is not more than 10 200 mm ;

and the annular space is perlite insulated.

4.3.3.6 Allowances c

No allowance is required.

$$c = 0$$

NOTE External surfaces should be adequately protected against corrosion.

4.3.4 Supports and lifting points

The supports and lifting points shall be designed for the loads defined in 4.2, using established structural design methods and safety factors.

When designing the inner vessel support system the temperature and corresponding mechanical properties to be used may be those of the component in question when the inner vessel is filled to capacity with cryogenic fluid.

4.3.5 Piping and accessories

Piping shall be designed for the loads defined in 4.2.3.7 using established piping design methods and safety factors.

4.3.6 Calculation formulae**4.3.6.1 Cylinders and spheres subject to internal pressure (pressure on the concave surface)****4.3.6.1.1 Field of application**

Cylinders and spheres where:

$$D_a/D_i \leq 1,2$$

4.3.6.1.2 Openings

For reinforcement of openings see 4.3.6.7.

4.3.6.1.3 Calculation

The required minimum wall thickness s is:

— for cylinders

$$s = \frac{D_a p}{20(K/S)v + p} + c \quad (1)$$

— for spheres

$$s = \frac{D_a p}{40(K/S)v + p} + c \quad (2)$$

4.3.6.2 Cylinders subject to external pressure (pressure on the convex surface)

4.3.6.2.1 Field of application

Cylinders where

$$D_a/D_i \leq 1,2$$

4.3.6.2.2 Openings

Openings shall be calculated in accordance with 4.3.6.7 using for the pressure in the formula a value equal to the external pressure as though it were internally applied.

4.3.6.2.3 Calculation

Calculations shall be performed for elastic buckling and for plastic deformation. The lowest calculated pressure p_e or p_p shall not be less than the external design pressure.

NOTE 1 The buckling length l_b is the length of the unsupported cylinder (see Figures 1 and 2). Other forms of stiffening section can be used.

NOTE 2 For vessels with dished ends, the buckling length starts at the junction of the cylinder and the knuckle region of the dished end (see Figure 3).

4.3.6.2.4 Elastic buckling

Calculations are performed using the following formula:

$$p_e = \frac{E}{S_k} \left\{ \frac{20}{(n^2 - 1) \cdot [1 + (n/Z)^2]^2} \cdot \frac{s - c}{D_a} + \frac{80}{12 \cdot (1 - \nu^2)} \cdot \left[n^2 - 1 + \frac{2n^2 - 1 - \nu}{1 + (n/Z)^2} \right] \cdot \left[\frac{s - c}{D_a} \right]^3 \right\} \quad (3)$$

where $Z = 0,5\pi D_a/l_b$ and n is an integer equal to or greater than 2 and greater than Z , so determined that the value for p_e is a minimum. n denotes the number of lobes produced by the buckling process which can occur at the circumference in the event of failure. The number of lobes can be estimated using the following approximation equation :

$$n = 1,63 \cdot \sqrt[4]{\frac{D_a^3}{l_b^2 (s - c)}} \quad (4)$$

For tubes and pipes, calculations may be performed using the following simplified formula:

$$p_e = \frac{E}{S_k} \cdot \frac{20}{(1 - \nu^2)} \cdot \left(\frac{s - c}{D_a} \right)^3 \quad (5)$$

If a test pressure higher than 1,25 p is specified, an additional assessment shall be made to ensure that the adopted material thickness is not less than that determined at test pressure with a safety factor of 0,74 S_k .

4.3.6.2.5 Plastic deformation

When $D_a/l_b \leq 5$

$$p_p = \frac{20K}{S_p} \cdot \frac{s-c}{D_a} \cdot \frac{1}{1 + \frac{1,5u(1-0,2D_a/l_b)D_a}{100(s-c)}} \quad (6)$$

When $D_a/l_b > 5$

the higher pressure obtained using equations (7) and (8) shall not be less than the external design pressure.

$$p_p = \frac{20K}{S_p} \cdot \frac{s-c}{D_a} \quad (7)$$

$$p_p = \frac{30K}{S_p} \left(\frac{s-c}{l_b} \right)^2 \quad (8)$$

If a test pressure higher than $1,25 p$ is specified, an additional assessment shall be made to ensure that the adopted material thickness is not less than that determined at the test pressure with a safety factor of $0,74 S_k$.

4.3.6.2.6 Stiffening rings

In addition to the ends, stiffening may be provided in the form of the examples shown in Figures 1 and 2. Other forms of stiffening may be used. The stiffening rings welded to the shell shall satisfy the following conditions:

$$I \geq \frac{0,124 p D_a^3}{10E} \sqrt{D_a(s-c)} \quad (9)$$

$$A \geq \frac{0,75 p D_a}{10K} \sqrt{D_a(s-c)} \quad (10)$$

The moment of inertia I is relative to the neutral axis of the reinforcing elements cross-section parallel to the shell axis (see axis $x - x$ in Figures 1 and 2). Narrow and high reinforcing elements of the kind shown in Figure 1 may undergo severe buckling. Where the height of the element is greater than 8 times its width, a more accurate calculation shall be made.

Where stiffening rings are joined to the shell by means of intermittent welds, the fillet welds at each side shall cover at least one third of the shell circumference and the number of weld discontinuities shall be at least $2n$. The number of buckling lobes n is obtained as indicated in 4.3.6.2.4.

If a test pressure, p_T , higher than $1,25 p$ is specified, an additional assessment shall be made to ensure that the adopted values of I and A are not less than those determined by formulae (9) and (10) at a pressure of $0,74 p_T$.

4.3.6.3 Spheres subject to external pressure (pressure on the convex surface)

Spheres subject to external pressure shall be evaluated in accordance with the appropriate part of 4.3.6.4.4.

4.3.6.4 Dished ends subject to internal or external pressure

4.3.6.4.1 Field of application

Hemispherical ends where $D_a/D_i \leq 1,2$

10 % torispherical ends where $R = D_a$ and $r = 0,1 D_a$

and

2:1 torispherical ends where $R = 0,8 D_a$ and $r = 0,154 D_a$

In the case of torispherical ends $0,001 \leq \frac{(s-c)}{D_a} \leq 0,1$

NOTE Other end shapes can be used provided suitable calculations are carried out.

4.3.6.4.2 Straight flange

The straight flange length h_1 (Figure 4a)) shall be not less than:

— for 10 % torispherical ends, $3,5 s$;

— for 2:1 torispherical ends, $3,0 s$.

The straight flange may be shorter providing that in the case of inner vessels the circumferential joint between the dished end and the cylinder is non-destructively tested as required for a weld joint factor of 1,0.

NOTE Other flange/weld configurations can be used providing suitable calculations are carried out.

4.3.6.4.3 Intermediate heads

Heads, without limit to thickness, may be installed in accordance with of Figure F.2. The outside diameter of the head skirt shall be a close fit inside the ends of the adjacent sections of the cylinder.

The butt weld and fillet weld shall be adequately sized to jointly resist any relevant pressure, mechanical and thermal loads. This may be achieved by accurate detailed stress analysis and by adopting the criteria for acceptable stresses of annex A.

Where only pressure stresses are present, a simplified approach may be adopted such that the butt weld and fillet weld are sized to resist in shear a load equivalent to 1,5 times the maximum differential pressure across the head multiplied by the cross sectional area of the shell.

The allowable shear stress in this simplified case should not exceed $K/3$ where the area of the butt weld in shear is the width at the root of the weld multiplied by the circumferential length of the weld and the area of the fillet weld is the throat thickness multiplied by times the circumferential length of the weld.

Where the stresses in the attachment are fully analysed and assessed in accordance with annex A, the fillet weld may be omitted. In other cases the fillet weld shall be continuous.

4.3.6.4.4 Internal pressure calculation (pressure on concave surface)

4.3.6.4.4.1 Crown and hemisphere thickness

The wall thickness of the crown region of dished ends and of hemispherical ends shall be determined using 4.3.6.1.3 for spheres with $D_a = 2(R + s)$.

Openings within the crown area of $0,6 D_a$ of torispherical ends, see Figure 4b), and in hemispherical ends shall be reinforced in accordance with 4.3.6.7. When pad type reinforcement is used the edge of the pad shall not extend beyond the area of $0,8 D_a$ for 10 % torispherical ends or $0,7 D_a$ for 2:1 torispherical ends.

4.3.6.4.4.2 Torispherical end knuckle thickness and hemispherical end to shell junction thickness

The required thickness of the knuckle region and hemispherical end junction shall be:

$$s = \frac{D_a p \beta}{40 \left(\frac{K}{S} \right)^v} + c \quad (11)$$

For hemispherical ends a β value of 1,1 shall be applied within the distance x from the tangent line joining the end to the cylinder,

where

$$x = 0,5 \sqrt{R(s - c)}$$

β is taken from Figure 5 for 10 % torispherical ends and from Figure 6 for 2:1 torispherical ends as a function of $\frac{(s - c)}{D_a}$. Iteration is necessary.

When there are openings outside the area $0,6 D_a$ the required thickness is found using β from Figures 5 and 6 using the appropriate curve for the relevant value of $\frac{d_i}{D_a}$.

The β factor is derived from the lower curves of Figures 5 and 6 when there are no openings outside the area $0,6 D_a$.

D_a is the diameter of the end as shown in Figures 4a) and 4b).

4.3.6.4.4.3 If a domed end is welded together from crown and knuckle components, the joint shall be at a sufficient distance x from the knuckle. The distance regarded as sufficient is as follows, but with a minimum, however, of at least 100 mm (see Figure 4c)):

— the crown and knuckle are of different wall thickness:

$$x = 0,5 \sqrt{R(s - c)}$$

where s is the required wall thickness of the knuckle.

— the crown and knuckle are of equal wall thickness:

— for 10 % torispherical ends $x = 3,5 s$;

— for 2:1 torispherical ends $x = 3,0 s$.

$v = 1,0$ may be applied if the scope of testing corresponds to that specified for a design stress level equal to the permissible design stress level or in the case of one-piece ends.

$v = 1,0$ may also be applied in the case of welded domed ends - except hemispherical ends - regardless of the scope of testing provided the weld intersects the crown area of $0,6 D_a$ (see Figures 4e) and 4f (left-hand side)).

4.3.6.4.4 If the ligament on the connecting line between adjacent openings is not entirely within the $0,6 D_a$ region the ligament shall not be less than half the sum of the opening diameters.

4.3.6.4.5 External pressure calculations (pressure on the convex surface)

Elastic buckling

There is adequate resistance to elastic buckling when:

$$p \leq 3,66 \frac{E}{S_k} \left(\frac{s-c}{R} \right)^2 \tag{12}$$

If a test pressure higher than $1,25 p$ is specified, the adopted material thickness shall not be less than:

$$s = R \cdot \sqrt{\frac{0,2 \cdot S_k \cdot \text{Test pressure}}{E}} + c \tag{13}$$

where

S_K safety factor determined from 4.3.2.4 or 4.3.3.4.

Plastic deformation and plastic buckling

Resistance to plastic deformation shall be determined by using 4.3.6.4.4 with the appropriate safety factor S_p defined in 4.3.2.4 and 4.3.3.4.

If a test pressure higher than $1,25 p$ is specified, an additional assessment shall be made to ensure that the adopted material thickness is not less than that determined at the pressure with a safety factor not less than $0,74 S_k$.

4.3.6.5 Cones subject to internal or external pressure

4.3.6.5.1 Symbols and units

For the purposes of 4.3.5.5, the following symbols apply in addition to those given in 3.2:

A	area of reinforcing ring	mm ²
D_{a1}	outside diameter of connected cylinder (see Figure 7)	mm
D_{a2}	outside diameter at effective stiffening (see Figure 9)	mm
D_k	design diameter (see Figure 7)	mm
D_s	shell diameter at nozzle (see Figure 8)	mm
I	moment of inertia about the axis parallel to the shell	mm ⁴
l	cone length between effective stiffenings (see Figure 9)	mm

s_g	required wall thickness outside corner area	mm
s_l	required wall thickness within corner area	mm
x_i	characteristic lengths ($i = 1,2,3$) to define corner area (Figures 7a and 7b and 4.3.5.5.5)	mm
φ	cone angle	°
r	inside radius of knuckle	mm

4.3.6.5.2 Field of application

Cones according to Figure 7 where:

$$0,001 \leq \frac{s_g c}{D_{a1}} \leq 0,1$$

and

$$0,001 \leq \frac{s_1 c}{D_{a1}} \leq 0,1$$

Small ends with a knuckle can be safely assessed and verified as a small end with a corner joint.

For external pressure $|\varphi| \leq 70^\circ$

Other cone angles may be used providing suitable calculations are carried out.

4.3.6.5.3 Openings

Openings outside of the corner area (see Figure 8) shall be designed as follows.

If $|\varphi| < 70^\circ$ design according to 4.3.6.7 using an equivalent cylinder diameter of:

$$D_i = \frac{D_s + d_i |\sin \varphi|}{\cos \varphi} \quad (14)$$

$|\varphi| \geq 70^\circ$ design according to 4.3.5.6.

4.3.6.5.4 Non destructive testing

All corner joints shall be subject to the examination required for a weld joint factor v of 1,0. See Table 6 in clause 6.

4.3.6.5.5 Corner area

The corner area is that part of the cone where the dominant stresses are bending stresses in the longitudinal direction.

The corner area is defined in Figures 7a and 7b by x_1, x_2, x_3 calculated from the following equations:

$$x_1 = \sqrt{D_{a1}(s_l - c)} \tag{15}$$

$$x_2 = 0,7 \sqrt{\frac{D_{a1}(s_l - c)}{\cos\varphi}} \tag{16}$$

$$x_3 = 0,5x_1 \tag{17}$$

4.3.6.5.6 Internal pressure calculation (pressure on concave surface) $|\varphi| \leq 70^\circ$

a) within corner area

The required wall thickness (s_1) within the corner area is calculated from Figures 10 a) to g) for the large end and Figure 10 h) for the small end of a cone using the following variables:

$$\varphi, \frac{pS}{15KV}, \text{ and } \frac{r}{D_{a1}}$$

For a corner joint use the curve for $\frac{r}{D_{a1}} = 0$.

For intermediate cone angles use linear interpolation. The wall thickness s_l in the corner area shall not be less than the required thickness s_g outside of the corner area as calculated in formula (18).

b) outside corner area

The required wall thickness, s_g , outside the corner area is calculated from:

$$s_g = \frac{D_k p}{20 \frac{K}{S} v - p} \div \frac{1}{\cos\varphi} + c \tag{18}$$

where

for the large end, $D_k = D_{a1} - 2[s_1 + r(1 - \cos\varphi) + x_2 \sin\varphi]$.

For the small end, D_k is the maximum diameter of the cone, where the wall thickness is s_g .

4.3.6.5.7 Internal pressure calculation (pressure on the concave surface) $|\varphi| > 70^\circ$

If $r \geq 0,01 D_{a1}$ the required wall thickness is

$$s_l = s_g = 0,3(D_a l - r) \frac{|\varphi|}{90} \sqrt{\frac{p}{10 \left(\frac{k}{S}\right)^v}} + c \tag{19}$$

4.3.6.5.8 External pressure calculation (pressure on the convex surface)

Stability against elastic buckling and plastic deformation shall be verified using 4.3.6.2 and an equivalent cylinder.

For the example shown in Figure 9 the equivalent cylinder diameter between the knuckle and the stiffener is:

$$D_a = \frac{D_{a1} + D_{a2}}{2 \cos|\varphi|} \quad (20)$$

and the equivalent cylinder length is:

$$l = \frac{D_{a1} - D_{a2}}{2 \sin|\varphi|} \quad (21)$$

Depending on the relevant boundary conditions the equivalent length between two effective stiffening sections shall be reliably estimated within the meaning of 4.3.6.2.

When $\varphi \geq 10^\circ$ the corner area of a large end can be considered as effective stiffening.

For small ends the thickness in the corner area shall not be less than 2,5 times the required thickness of the conical shell with the same angle $|\varphi|$ or a stiffener shall be fitted with the following properties:

$$l \geq \frac{p(D_{a1})^4}{960 \left(\frac{E}{S_k} \right)} \tan|\varphi| \quad (22)$$

If a test pressure higher than $1,25 p$ is specified, an additional assessment shall be made to ensure that the adopted value of l is not less than that determined at the test pressure with a safety factor of $0,74 S_k$.

$$A \geq \frac{p(D_{a1})^2}{80 \left(\frac{K}{S_p} \right)} \tan|\varphi| \quad (23)$$

If a test pressure higher than $1,25 p$ is specified, an additional assessment shall be made to ensure that the adopted value of A is not less than that determined at the test pressure with a safety factor of $0,74 S_p$.

S_k (cylinder) is the safety factor to prevent elastic buckling from 4.3.2.4 or 4.3.3.4.

S_p (cylinder) is the safety factor to prevent plastic deformation from 4.3.2.4 or 4.3.3.4.

D_{a1} is the diameter according to Figure 7b).

The shell over a width of $0,5\sqrt{D_{a1}s_1}$ can be used to calculate the moment of inertia and the area.

In addition the corner joint should not be regarded as a classical boundary condition i.e. the overall length should be formed from the individual meridional length of the cone and cylinder.

In addition, the cone shall be verified using 4.3.6.5.6 and the safety factors S_p for cylinders from 4.3.2.4 or 4.3.3.4. If a test pressure higher than $1,25 p$ is specified, an additional assessment shall be made to ensure that the adopted material thickness is not less than that determined at the test pressure with a safety factor of $0,74 S_k$. For thickness calculations in the corner area v shall be the value applicable for internal pressure.

4.3.6.6 Flat ends

4.3.6.6.1 Symbols

For the purposes of 4.3.6.6, the following symbols apply in addition to those given in 3.2:

- d_1, d_2 etc. opening diameters in mm;
- D_1, D_2 etc. flat end diameters in mm.

4.3.6.6.2 Field of application

Welded or solid flat ends where Poisson's ratio is approximately 0,3, and

$$\frac{(s - c)}{D} \geq 4 \sqrt{\frac{0,0087 p}{E}}$$

and

$$\frac{(s - c)}{D} \leq \frac{1}{3}$$

4.3.6.6.3 Openings

Openings are calculated in accordance with 4.3.6.6.4 but with the C factor multiplied by C_A , where C_A is given in Figure 11.

4.3.6.6.4 Calculation

The required minimum wall thickness of a circular flat end is:

$$s = CD_1 \sqrt{\frac{0,1pS}{K}} + c \tag{24}$$

C and D_1 are taken from Figure 12.

The required minimum wall thickness of a rectangular or elliptical flat end is

$$s = CC_{Ef} \sqrt{\frac{0,1pS}{K}} + c \tag{25}$$

where C_E is taken from Figure 13.

4.3.6.7 Openings in cylinders, spheres and cones

4.3.6.7.1 Symbols and units

For the purposes of 4.3.6.7, the following symbols apply in addition to those given in 3.2:

b	width of pad, ring or shell reinforcement	mm
h	thickness of pad-reinforcement	mm
l	ligament (web) between two nozzles	mm

l'_s	length of nozzle reinforcement outstandings	mm
m	protruding length of nozzle	mm
s	length of nozzle reinforcement instand	mm
s_A	required wall thickness at opening edge	mm
s_S	wall thickness of nozzle	mm
t	In this context : centre-to-centre distance between two nozzles	mm

4.3.6.7.2 Field of application

Round openings and the reinforcement of round openings in cylinders, spheres and cones within the following limits:

$$0,002 \leq \frac{(s-c)}{D_a} \leq 0,1$$

$$\frac{(s-c)}{D_a} < 0,002 \text{ is acceptable if } \frac{d_i}{D_a} \leq \frac{1}{3}.$$

These rules only apply to cones if the wall thickness is determined by the circumferential stress.

NOTE 1 Additional external forces and moments are not covered by this sub-clause and are to be considered separately where necessary.

NOTE 2 These design rules permit plastic deformations of up to 1 % at highly stressed local areas during pressure test. Openings should therefore be carefully designed to avoid abrupt changes in geometry.

The design rules for non perpendicular nozzles shall be based on a perpendicular nozzle, using the dimension of the major elliptical axis or shall be calculated in accordance with EN 13445-3.

4.3.6.7.3 Reinforcement methods

Openings may be reinforced by one or more of the following typical but not exclusive methods:

- increase of shell thickness, see Figures 14 and 15;
- set in or set on ring reinforcement, see Figures 16 and 17;
- pad reinforcement, see Figure 18;
- increase of nozzle thickness, see Figures 19 and 20;
- pad and nozzle reinforcement, see Figure 21.

Where ring or pad reinforcement is used on the inner vessel the space between the two fillet welds shall be vented into the vacuum interspace.

4.3.6.7.4 Design of openings

The fillet weld on a reinforcing pad shall have a minimum throat thickness of half of the pad thickness.

The critical dimensions of each nozzle to shell weld shall be not less than the required thickness of the thinner part.

Where the strength of the reinforcing material is lower than the strength of the shell material an allowance in accordance with 4.3.6.7.5 shall be made in the design calculations. If the strength of the reinforcing material is higher than the strength of the shell material no allowance for the increased strength is permitted.

4.3.6.7.5 Calculation

Where the material property K of the reinforcement is lower than that of the shell the cross section of pad reinforcement and the thickness of nozzle reinforcement shall be reduced by the ratio of K values. In the case of a shell subjected only to internal pressure, with a row of nozzles joined to the shell by fully penetrating welds, it is not necessary to calculate the individual reinforcement required for each nozzle. However the thickness of the shell to resist internal pressure shall be calculated using the least value of weakening factor of either v_A obtained from equation (34) or v .

Openings shall also be reinforced according to the following relationship:

$$\frac{p}{10} \left(\frac{A_p}{A_\sigma} + \frac{1}{2} \right) \leq \frac{K}{S} \quad (26)$$

which is based on equilibrium between the pressurised area A_p and the load bearing cross sectional area A_σ . The wall thickness obtained from this relationship shall be not less than the thickness of the unpierced shell.

The pressurised area A_p and the load bearing cross sectional area A_σ which equals $A_{\sigma 0} + A_{\sigma 1} + A_{\sigma 2}$ are obtained from Figures 22 to 25.

The maximum extent of the load bearing cross sectional area shall be not more than b as defined in formula (28) for shells and l_s as defined in formulae (30) or (31) for nozzles, as appropriate.

The protrusion of nozzles l'_s may be included as load bearing cross sectional area up to a maximum length of:

$$l'_s = 0,5 l_s$$

The restrictions of 4.3.6.7.7 and 4.3.6.7.8 shall be observed.

If the material property K_1 , K_2 etc. of the reinforcing material is lower than that of the shell the dimensions shall comply with:

$$\left(\frac{K}{S} - \frac{p}{20} \right) A_{\sigma 0} + \left(\frac{K_1}{S} - \frac{p}{20} \right) A_{\sigma 1} + \left(\frac{K_2}{S} - \frac{p}{20} \right) A_{\sigma 2} \geq \frac{p}{10} A_p \quad (27)$$

4.3.6.7.6 Ring or pad reinforcement or increased shell thickness

If the actual wall thickness of the cylinder or sphere is less than the required thickness s_A at the opening, the opening is adequately reinforced if the wall thickness s_A is available round the opening over a width of:

$$b = \sqrt{(D_i + s_A - c)(s_A - c)} \quad (28)$$

with a minimum of $3 s_A$ (see Figures 16, 17 and 18).

For calculation purposes s_A shall be limited to not more than twice the actual wall thickness.

The thickness of pad reinforcement in accordance with Figure 18 preferably shall be not more than the actual wall thickness to which the pad is attached.

Internal pad reinforcement is not allowed.

The width of the pad reinforcement may be reduced to b_1 provided the pad thickness is increased to h_1 according to:

$$b_1 \cdot h_1 \geq b \cdot h \quad (29)$$

and the limits given above are observed.

4.3.6.7.7 Reinforcement by increased nozzle thickness

For calculation purposes s_s shall be not more than twice the actual wall thickness.

The thickness of the nozzle shall preferably be not greater than twice the actual shell thickness.

The wall thickness s_A at the opening shall extend over a width b in accordance with formula (28) with a minimum of $3 s_A$.

The limits of reinforcement normal to the vessel wall are:

— for cylinders and cones, $l_s = 1,25 \sqrt{(d_i - s_s - c)(s_s - c)}$ (30)

— for spheres, $l_s = \sqrt{(d_i - s_s - c)(s_s - c)}$ (31)

The length l_s may be reduced to l_{s1} provided that the thickness s_s is increased to s_{s1} according to the following:

$$l_{s1} \cdot s_{s1} \geq l_s \cdot s_s \quad (32)$$

and the limits given above are observed.

4.3.6.7.8 Reinforcement by a combination of increased shell and nozzle thicknesses

Shell and nozzle thicknesses may be increased in combination for the reinforcement of openings (see Figure 21). For the calculation of reinforcement 4.3.6.7.6 and 4.3.6.7.7 shall be applied together. The increase in shell thickness may be achieved by an actual increase in shell thickness or the addition of a pad.

4.3.6.7.9 Multiple openings

Multiple openings are regarded as single openings provided the distance l between two adjacent openings, Figures 24 and 26, complies with:

$$l \geq 2 \sqrt{(D_i + s_A - c)(s_A - c)} \quad (33)$$

If l is less than required by formula (33) a check shall be made to determine whether the cross section between openings is able to withstand the load acting on it. Adequate reinforcement is available if the requirement of formula (26) or (27), as appropriate is met.

Where adjacent openings in a cylinder are arranged intermediately between the longitudinal and circumferential direction the calculation scheme for the longitudinal direction (see Figure 24) shall be applied, but the part of the pressurised area corresponding to the unpierced cylinder $\left(\frac{tD_i}{2}\right)$ may be reduced with an arrangement factor $= 0,5 (1 + \cos^2 \varphi)$.

See Figure 25 for angle φ .

Nozzles joined to the shell in line by full penetration welds with the wall thickness calculated for internal pressure only may be designed with a weakening factor:

$$v_A = \frac{(t - d_i)}{t} \tag{34}$$

If the nozzles are not attached by full penetration welds, D_a shall be used in formula (34).

4.3.7 Design by analysis

Unless the design has been validated by experiment, calculations in addition to those in 4.3.6 may be required to ensure that stresses due to operating loads are within acceptable limits. All load conditions expected during service shall be considered (see 4.2.3).

In these calculations static loads are substituted for static plus dynamic loads.

The analysis shall take account of gross structural discontinuities, but need not consider local stress concentrations.

Annex A provides terminology and acceptable stress limits when an elastic stress analysis is performed.

Acceptable calculation methods include:

- finite element ;
- finite difference ;
- boundary element ;
- recognised text books, published papers, codes and standards.

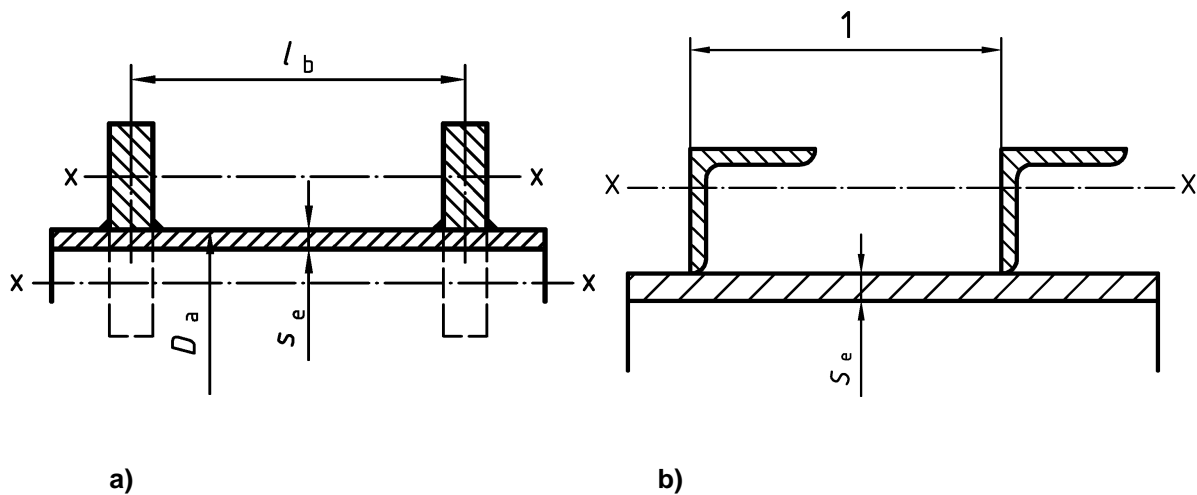

Figure 1 — Stiffening rings

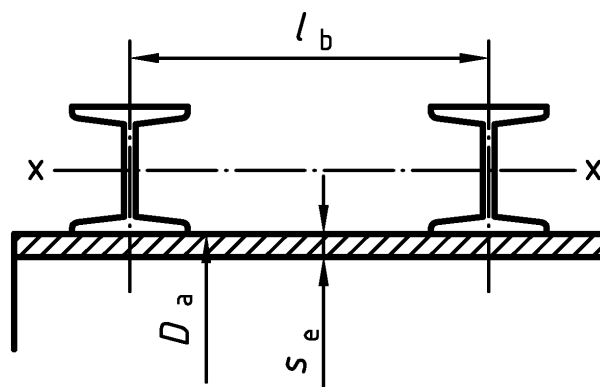

Figure 2 — Sectional materials stiffeners

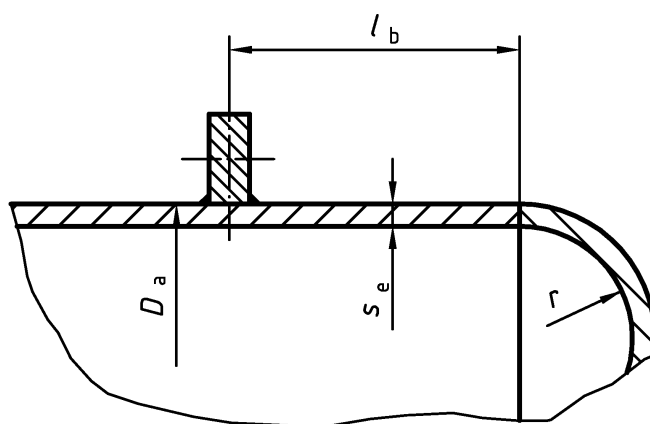
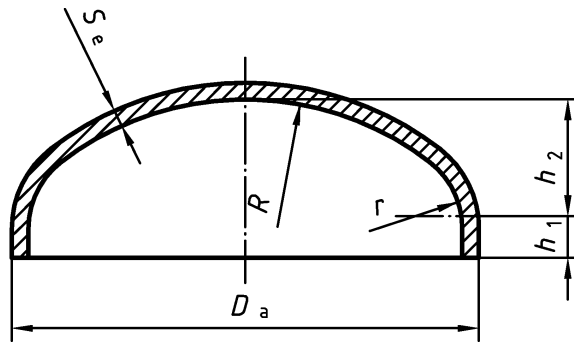
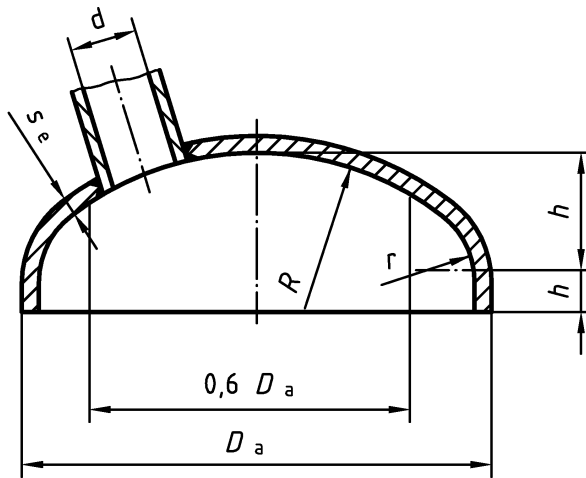

Figure 3 — Dished ends



a) — Unpierced dished end



b) — Dished end with nozzle

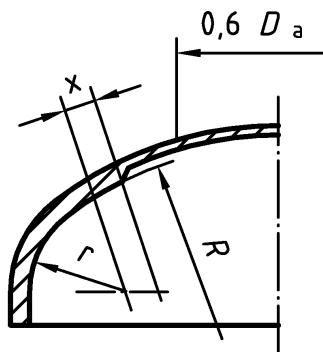

c) — End with knuckle and crown of unequal wall thickness

Figure 4

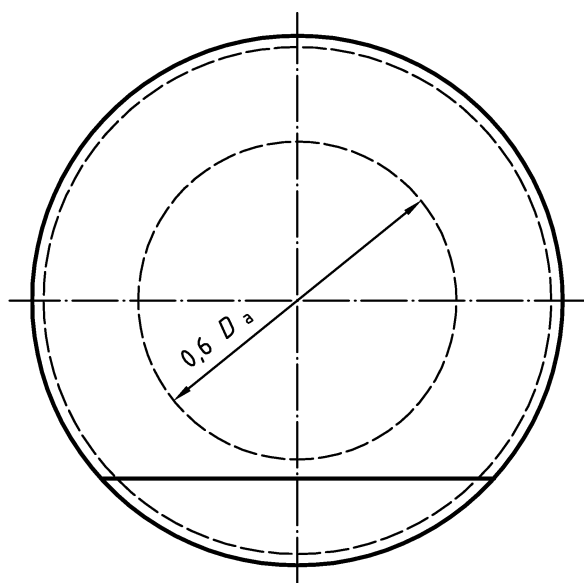

$v = 0,85$ or $1,0$

d) — Weld outside $0,6 D_a$

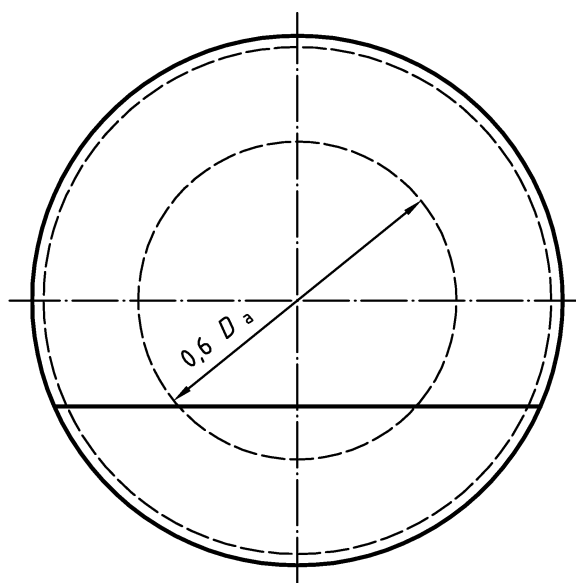

$v = 1,0$

e) — Weld inside $0,6 D_a$

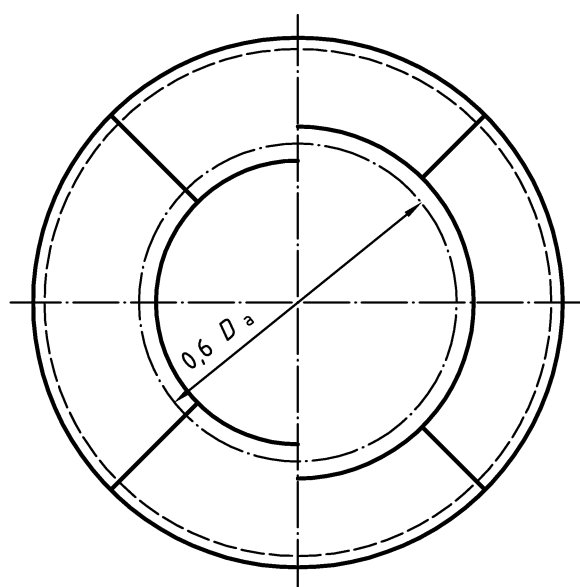

$v = 1,0$

$v = 0,85$ or $1,0$

f) — End welded together from round plate and segments

Figure 4

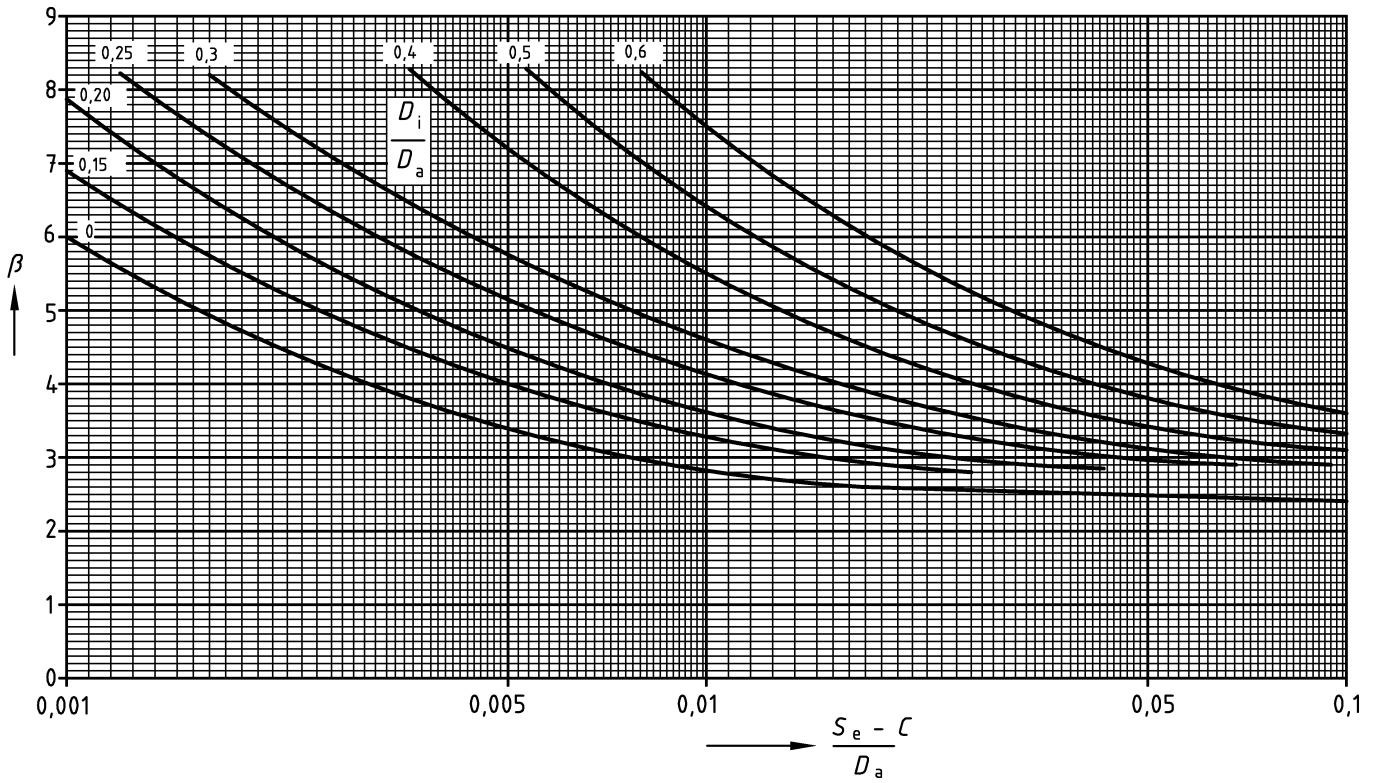

Figure 5 — Design factors β for 10 % torispherical dished ends

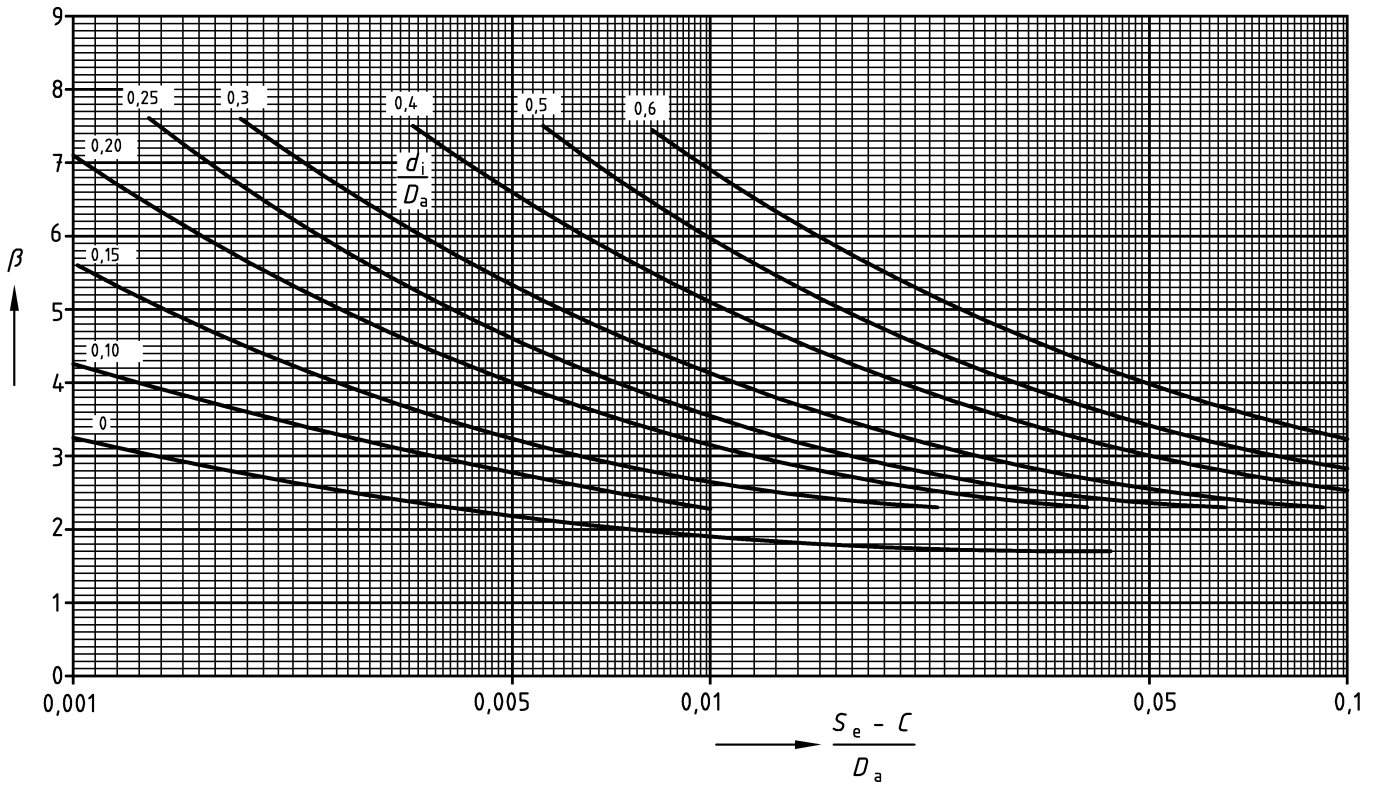
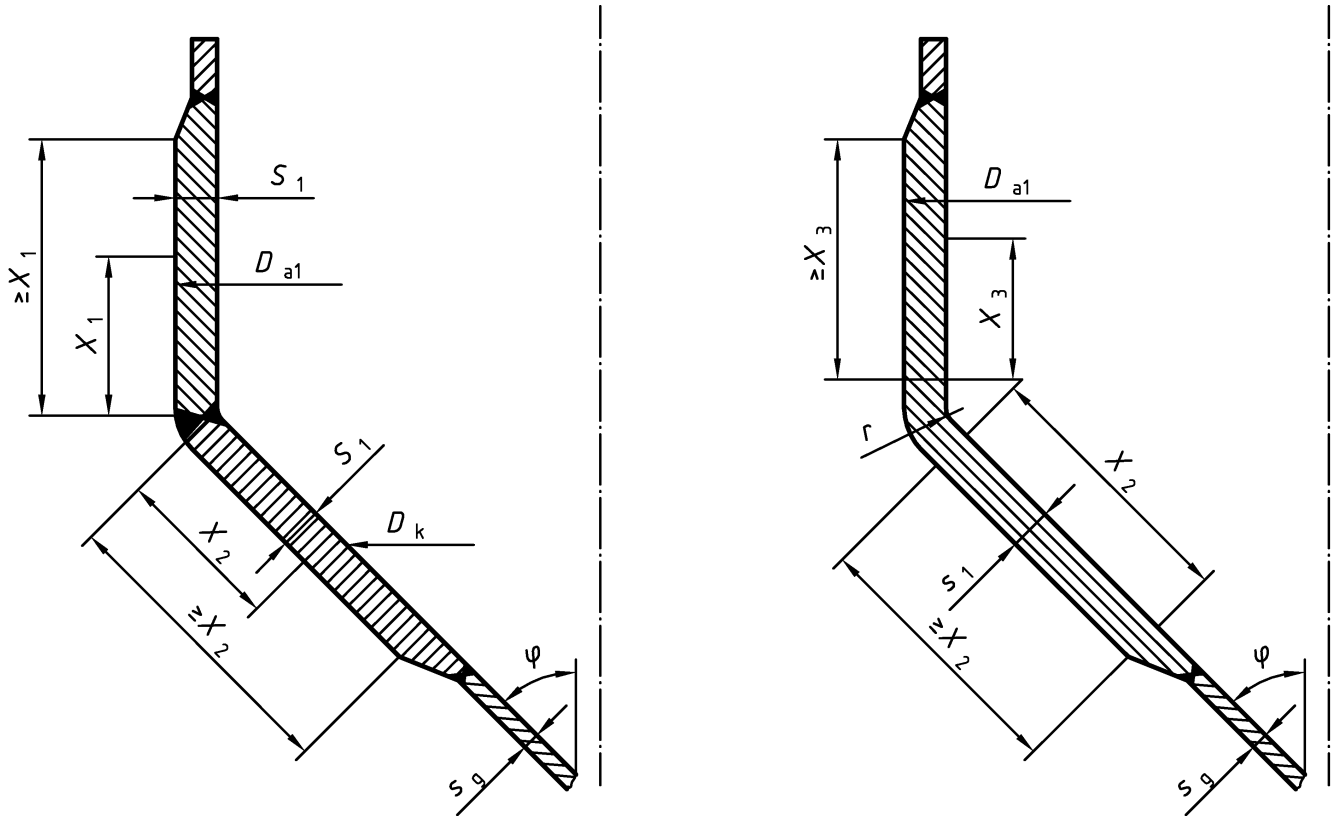
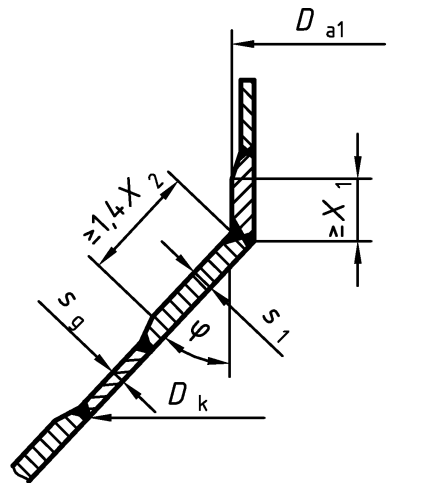

Figure 6 — Design factors β for 2:1 torispherical dished ends



a) — Geometry of convergent conical shells



b) — Geometry of a divergent conical shell

Figure 7

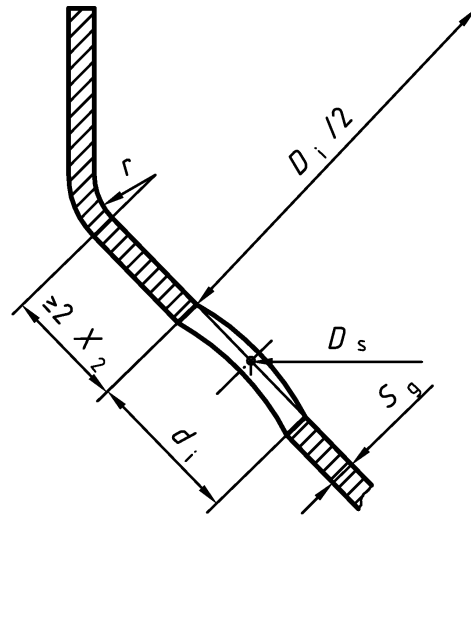

Figure 8 — Geometry of a cone opening

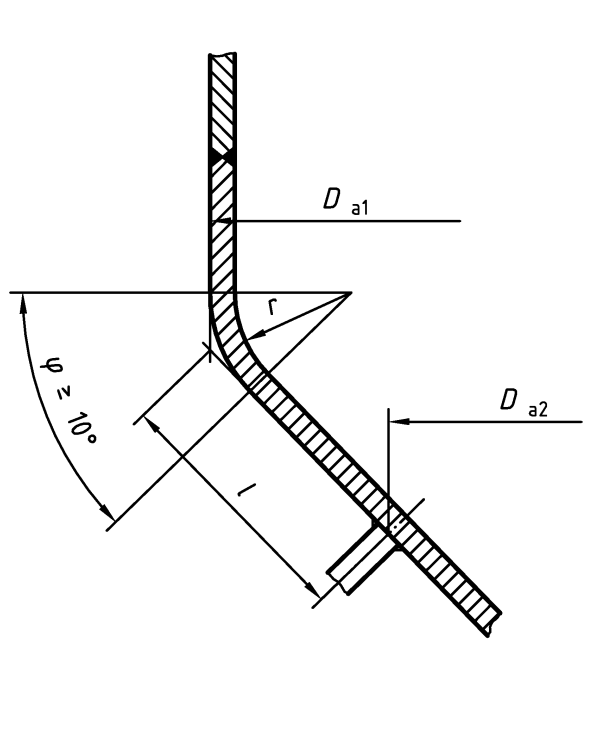

Figure 9 — Geometrical quantities in the case of loading by external pressure

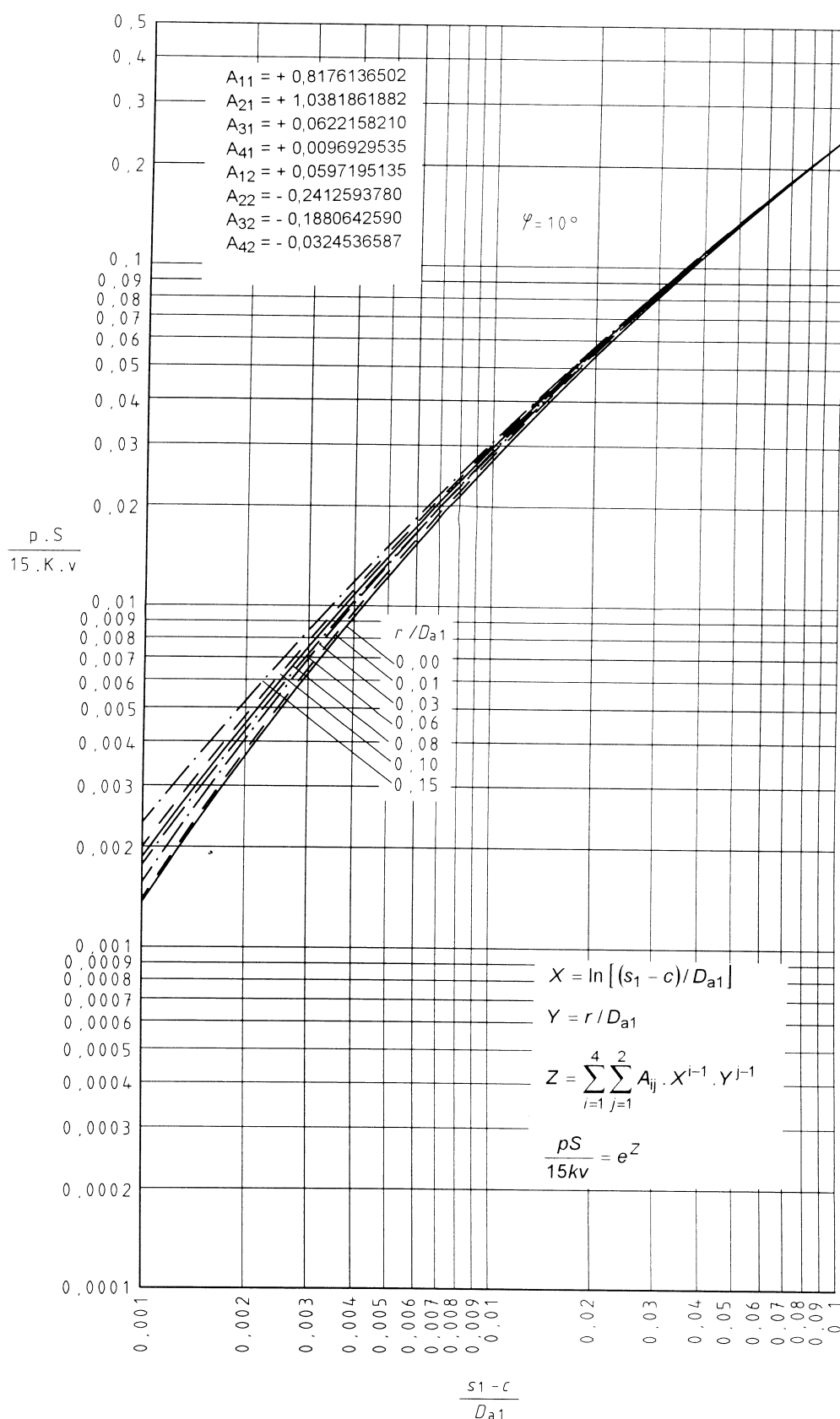

Figure 10 a) — Permissible value $\frac{pS}{15Kv}$ for convergent cone with an opening angle $\varphi = 10^\circ$

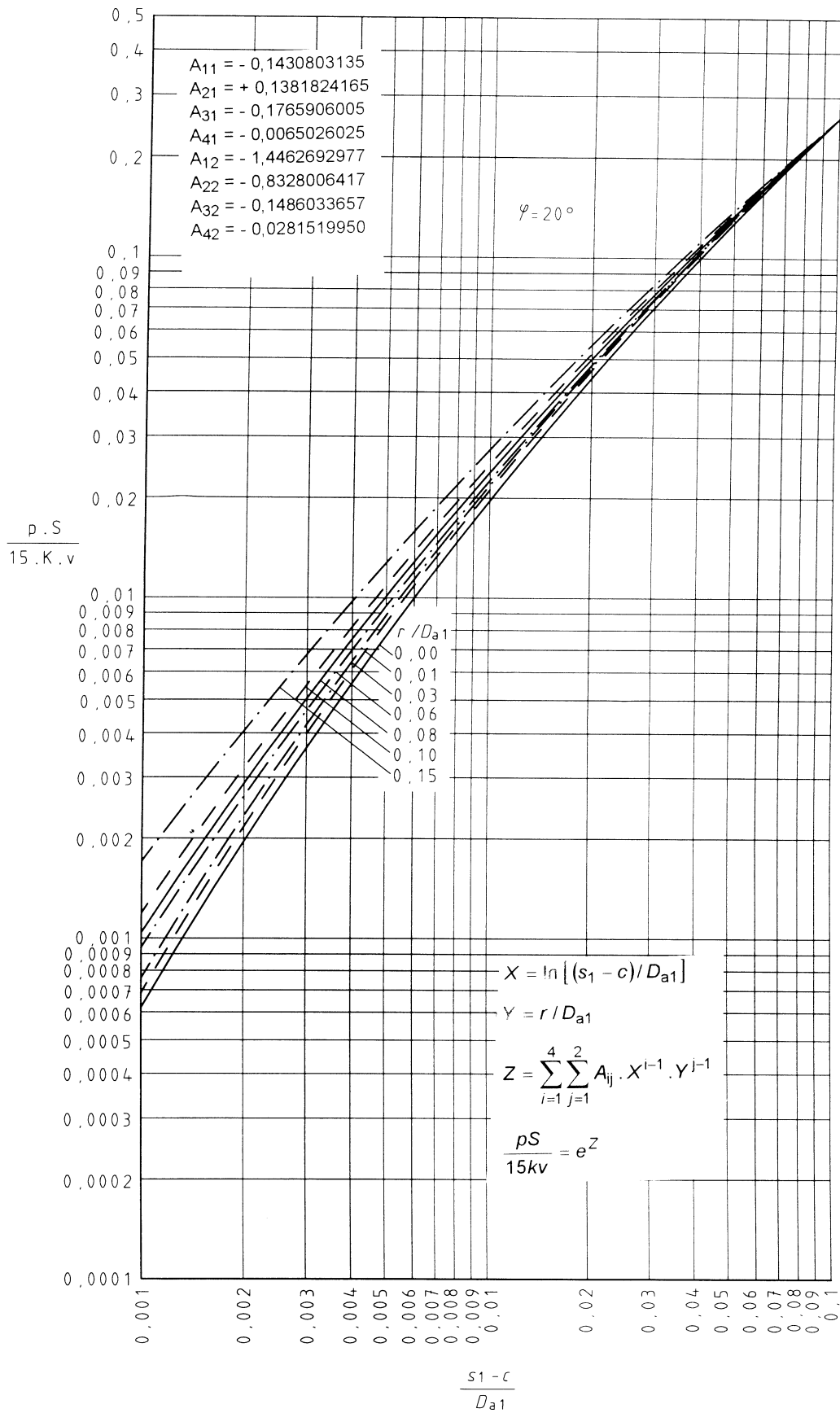

Figure 10 b) — Permissible value $\frac{pS}{15Kv}$ for convergent cone with an opening angle $\varphi = 20^\circ$

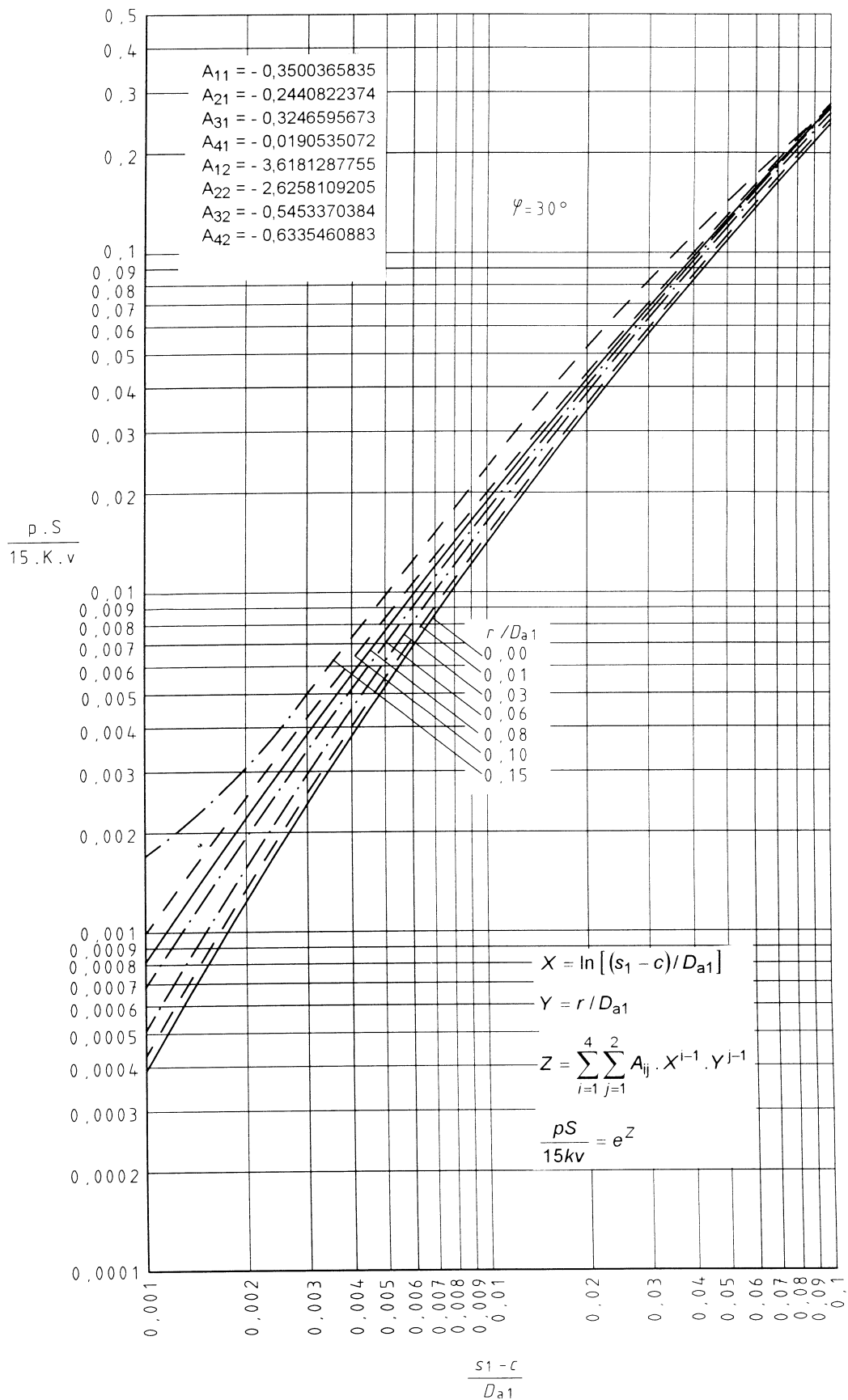

Figure 10 c) — Permissible value $\frac{pS}{15Kv}$ for convergent cone with an opening angle $\varphi = 30^\circ$

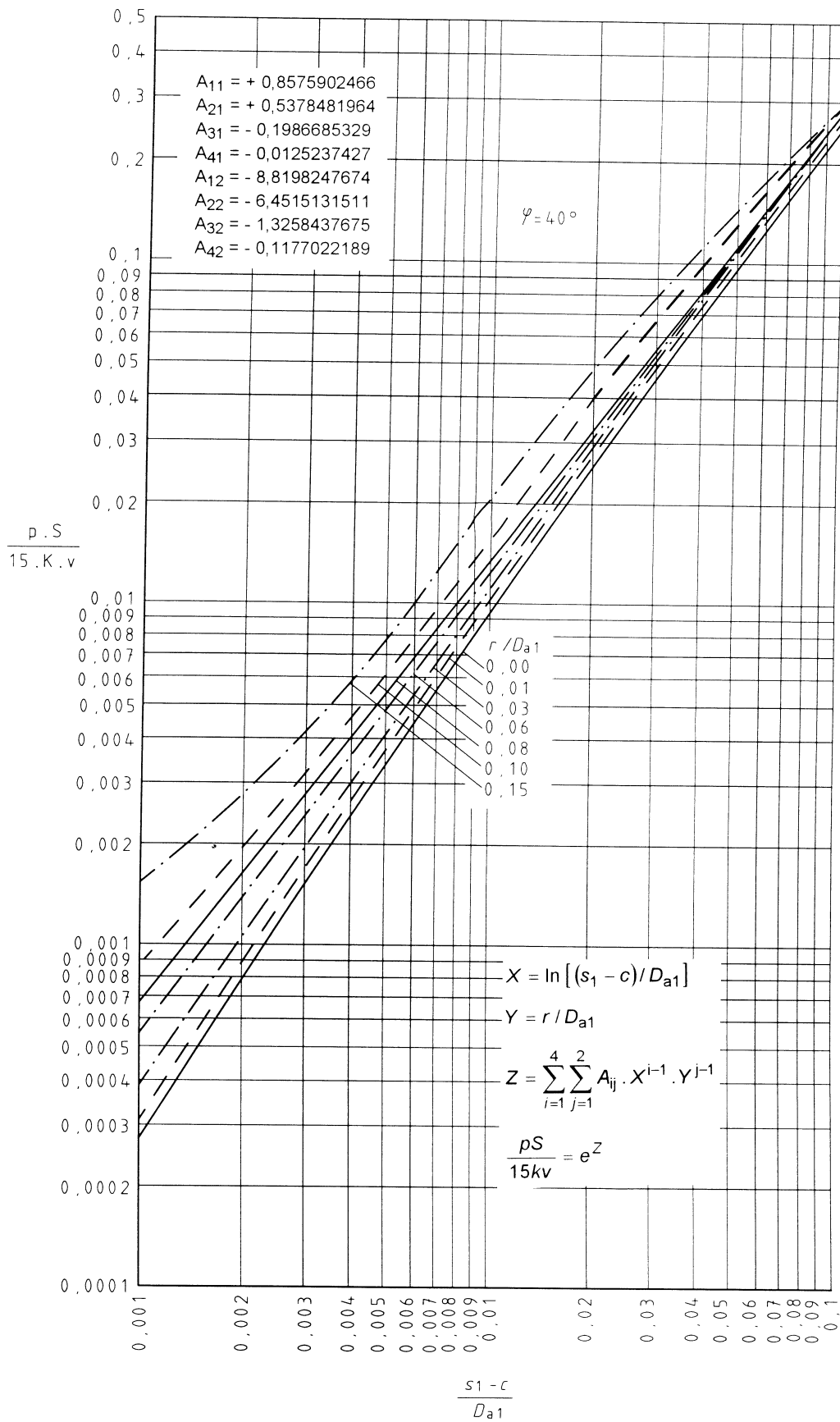

Figure 10 d) — Permissible value $\frac{pS}{15Kv}$ for convergent cone with an opening angle $\varphi = 40^\circ$

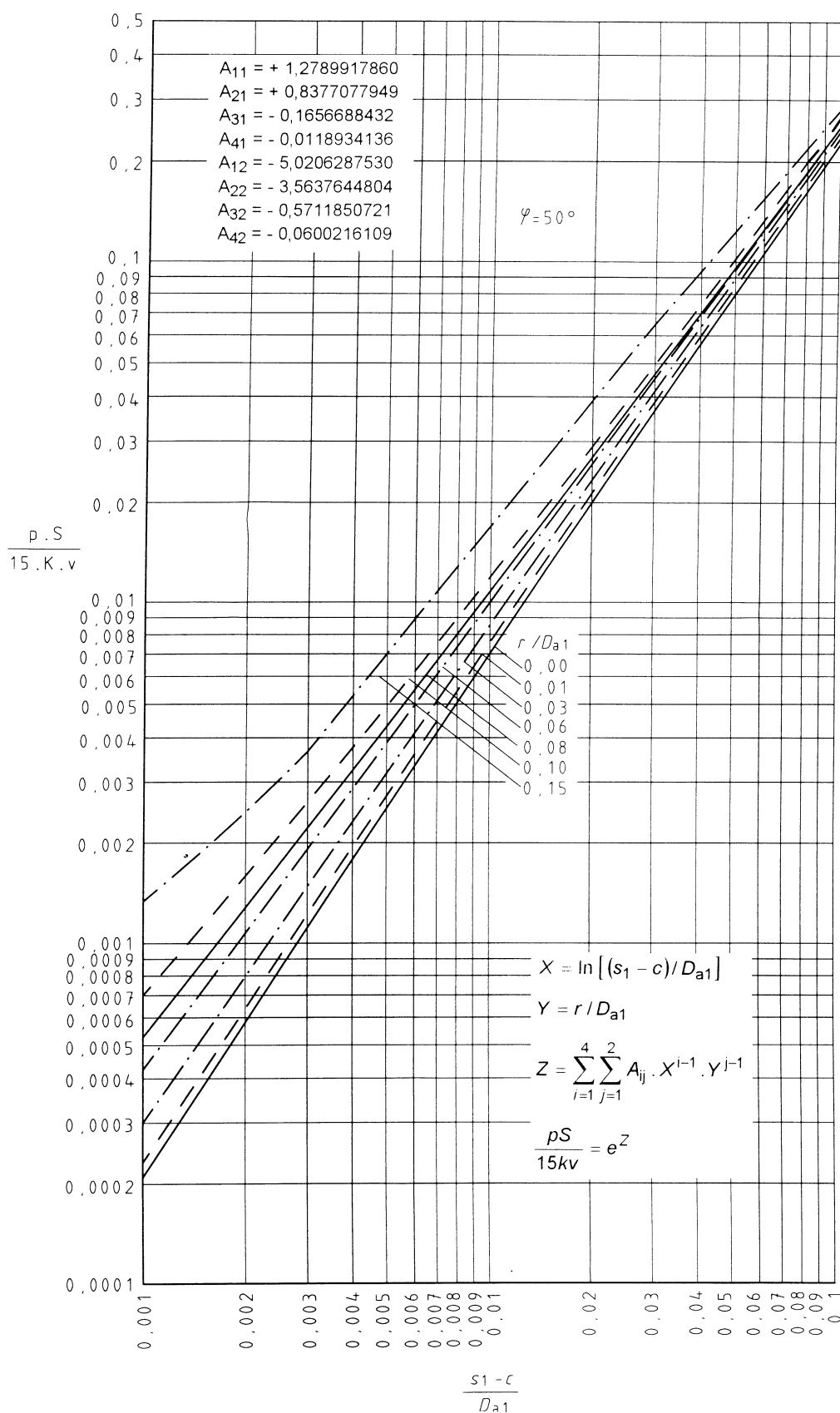

Figure 10 e) — Permissible value $\frac{pS}{15Kv}$ for convergent cone with an opening angle $\varphi = 50^\circ$

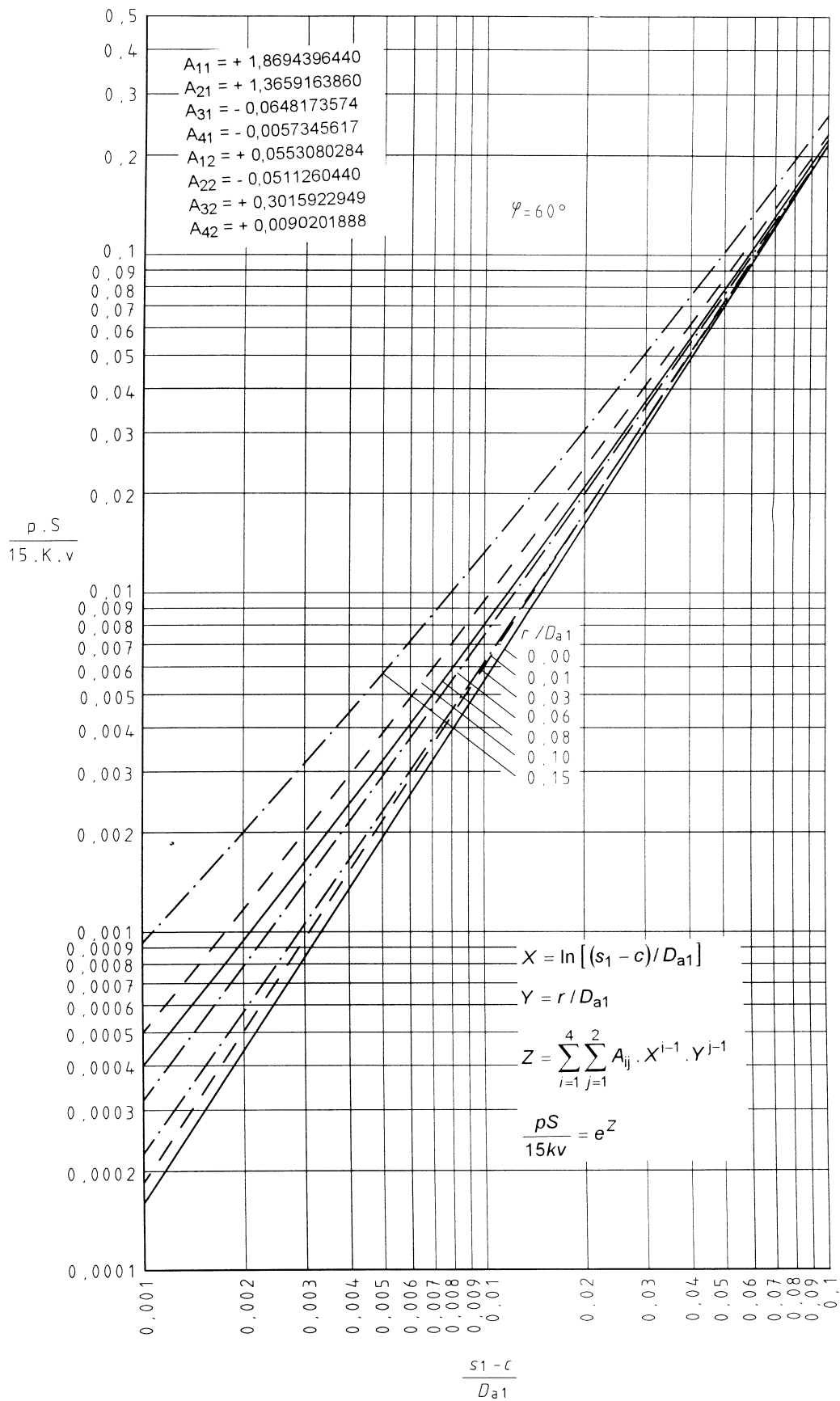

Figure 10 f) — Permissible value $\frac{pS}{15KV}$ for convergent cone with an opening angle $\varphi = 60^\circ$

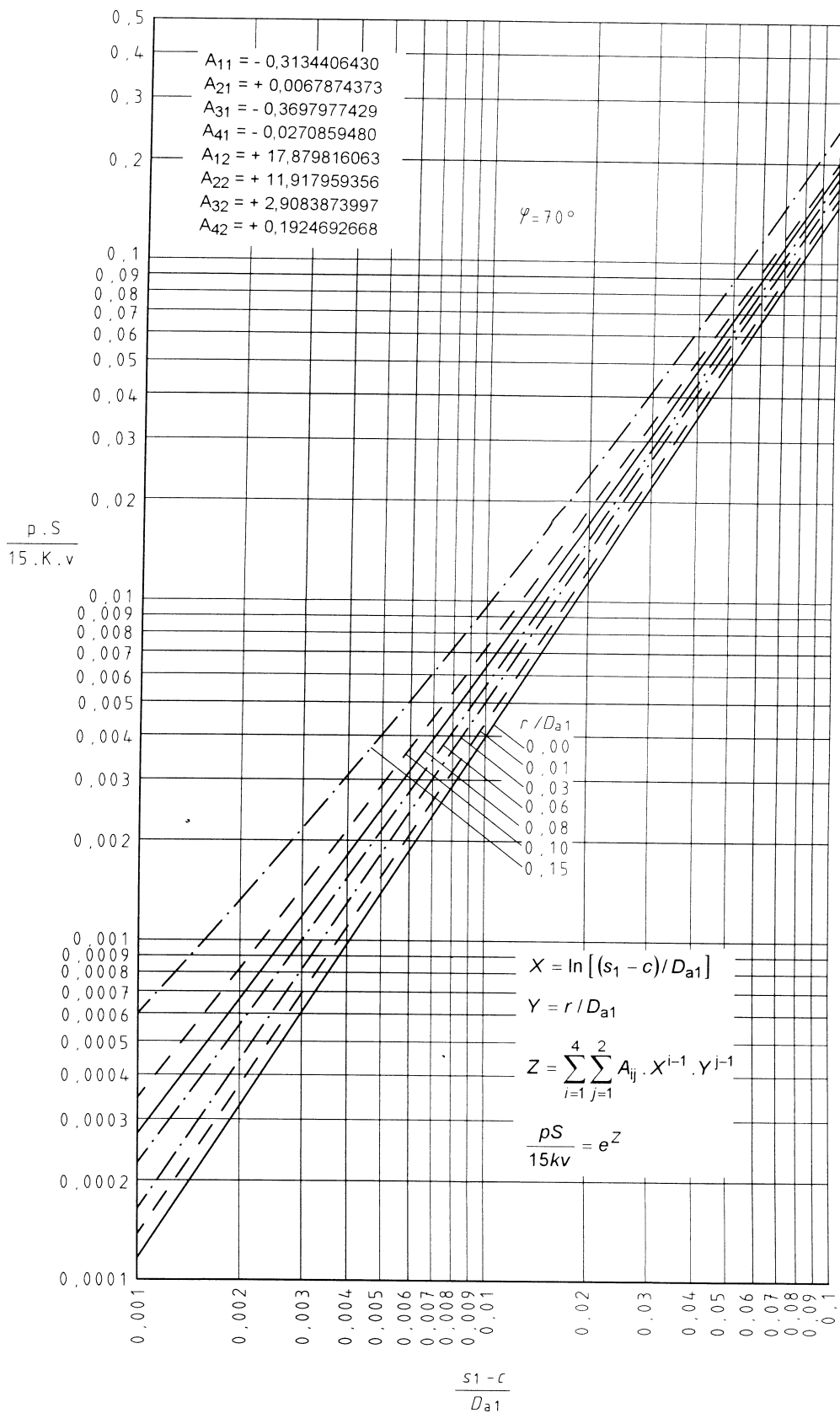

Figure 10 g) — Permissible value $\frac{pS}{15KV}$ for convergent cone with an opening angle $\varphi = 70^\circ$

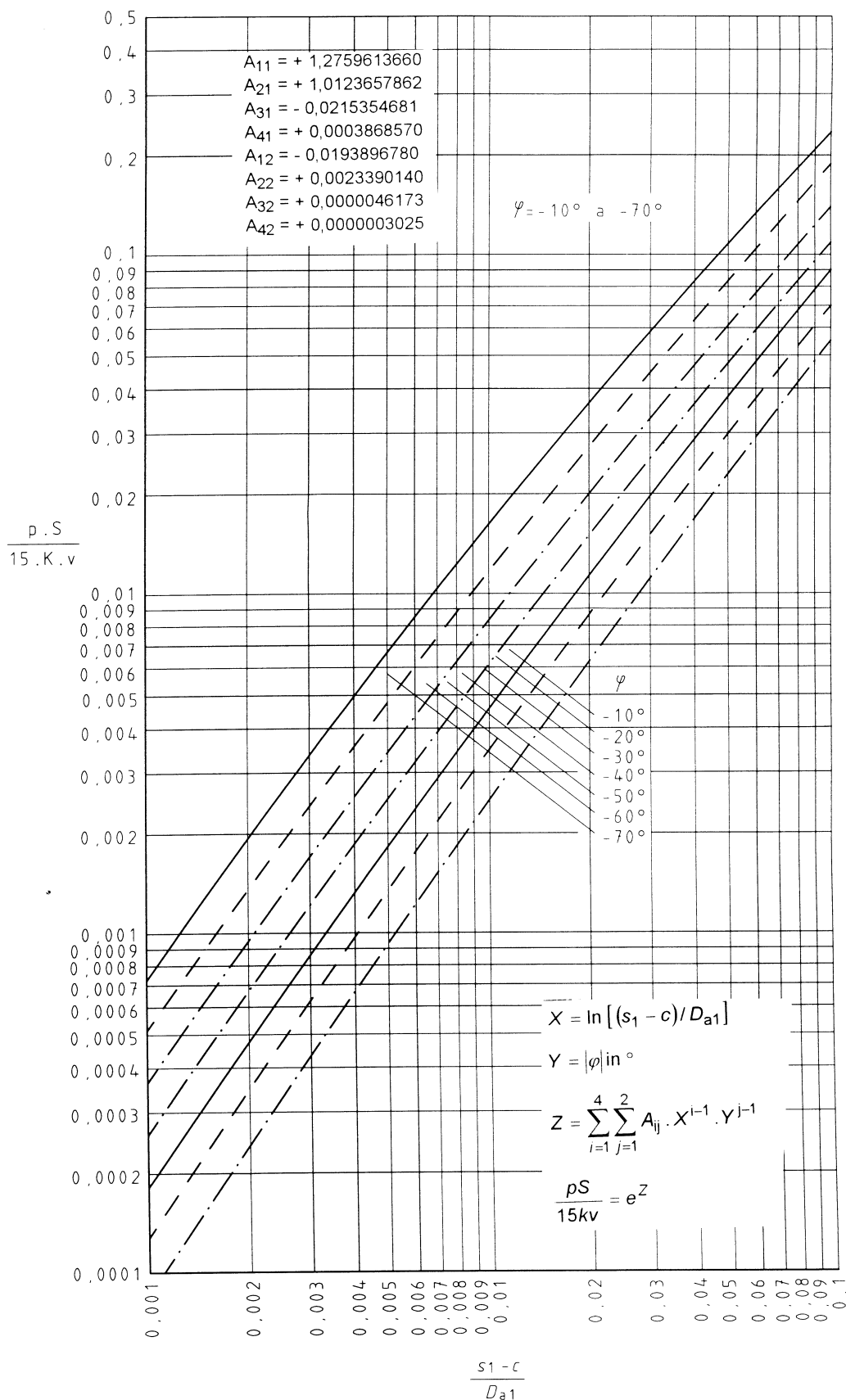
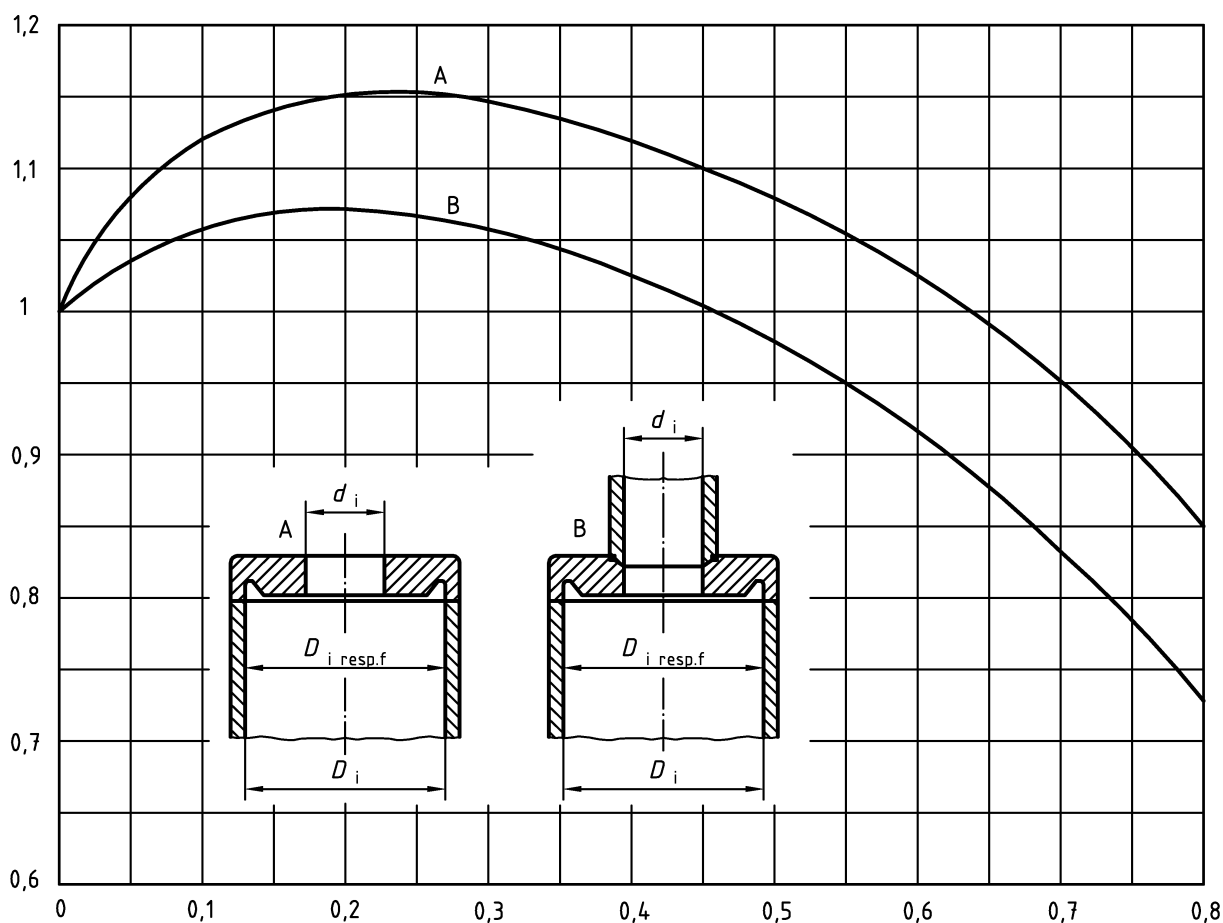

Figure 10 h) — Permissible value $\frac{pS}{15Kv}$ for convergent cone (corner joint) with an opening angle $\varphi = 10^\circ$ to 70°



Key

- 1 Opening factor C_A
- 2 Ratio d_i/D_i resp. d_i/f

Type A

d = inside diameter of opening

D_i = design diameter

f = short side of elliptical end

$$C_A = \begin{cases} \sum_{i=1}^6 A_i \left(\frac{d}{D_i} \right)^{i-1} & \left| 0 < \left(\frac{d}{D_i} \right) \leq 0,8 \right. \\ \sum_{i=1}^6 A_i \left(\frac{d}{f} \right)^{i-1} & \left| 0 < \left(\frac{d}{f} \right) \leq 0,8 \right. \end{cases}$$

$$A_1 = 0,999\ 034\ 20$$

$$A_2 = 1,980\ 626\ 00$$

$$A_3 = 9,018\ 554\ 00$$

$$A_4 = 18,632\ 830\ 00$$

$$A_5 = 19,497\ 590\ 00$$

$$A_6 = 7,612\ 568\ 00$$

Type B

d = inside diameter of opening

D_i = design diameter

f = short side of elliptical end

$$C_A = \begin{cases} \sum_{i=1}^6 A_i \left(\frac{d}{D_i} \right)^{i-1} & \left| 0 < \left(\frac{d}{D_i} \right) \leq 0,8 \right. \\ \sum_{i=1}^6 A_i \left(\frac{d}{f} \right)^{i-1} & \left| 0 < \left(\frac{d}{f} \right) \leq 0,8 \right. \end{cases}$$

$$A_1 = 1,001\ 003\ 44$$

$$A_2 = 0,944\ 284\ 68$$

$$A_3 = 4,312\ 102\ 00$$

$$A_4 = 8,389\ 435\ 00$$

$$A_5 = 9,206\ 283\ 84$$

$$A_6 = 3,694\ 941\ 96$$

Figure 11 — Opening factor C_A for flat ends and plates without additional marginal moment

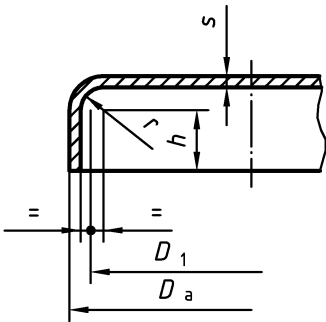
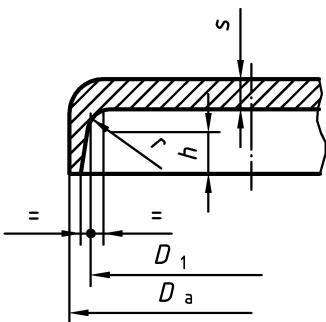
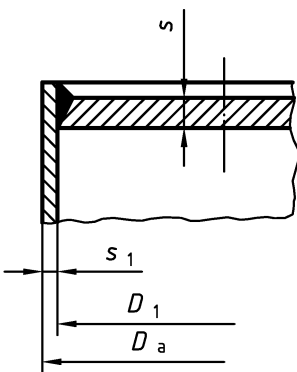
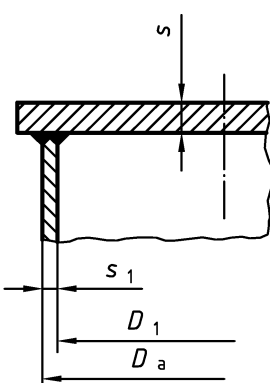
Type of flat end design (principle only)	Conditions	Design factor <i>C</i>												
<p>a) flat end</p> 	<p>1. knuckle radius :</p> <table border="1" data-bbox="837 309 1294 499"> <thead> <tr> <th>D_a</th> <th>r_{min}</th> </tr> </thead> <tbody> <tr> <td>up to 500</td> <td>30</td> </tr> <tr> <td>over 500 up to 1 400</td> <td>35</td> </tr> <tr> <td>over 1 400 up to 1 600</td> <td>40</td> </tr> <tr> <td>over 1 600 up to 1 900</td> <td>45</td> </tr> <tr> <td>over 1 900</td> <td>50</td> </tr> </tbody> </table> <p>and $r \geq 1,3 s$ 2. cylindrical part : $h \geq 3,5 \times s$</p>	D_a	r_{min}	up to 500	30	over 500 up to 1 400	35	over 1 400 up to 1 600	40	over 1 600 up to 1 900	45	over 1 900	50	<p>0,30</p>
D_a	r_{min}													
up to 500	30													
over 500 up to 1 400	35													
over 1 400 up to 1 600	40													
over 1 600 up to 1 900	45													
over 1 900	50													
<p>b) forged or pressed flat end</p> 	<p>1. knuckle radius : $r \geq \frac{s}{3}$, however at least 8 mm 2. cylindrical part : $h \geq s$</p>	<p>0,35</p>												
<p>c) flat plate welded into the shell from both sides</p> 	<p>plate thickness : $s \leq 3 s_1$ $s > 3 s_1$</p>	<p>0,35 0,40</p>												
<p>d) plate welded into the shell with welds at both sides of the latter</p> 	<p>plate thickness : $s \leq 3 s_1$ $s > 3 s_1$ Only killed steels may be utilised. When plate material is employed, over an area of at least $3 s_1$ in the weld zone there shall be no evidence of material discontinuities in the plate.</p>	<p>0,40 0,45</p>												

<p>e) flat plate welded into the shell from one side only</p> 	<p>plate thickness :</p> <p>$s \leq 3 s_1$</p> <p>$s > 3 s_1$</p>	<p>0,45</p> <p>0,50</p>
---	--	-------------------------

Figure 12 — Design factors for unstayed circular flat ends and plates



Key

- 1 Design factor C_e
- 2 Ratio f/e

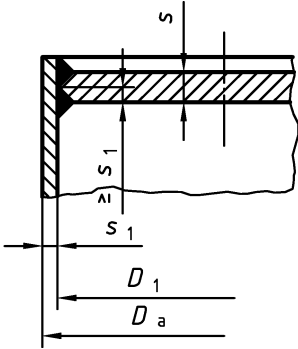
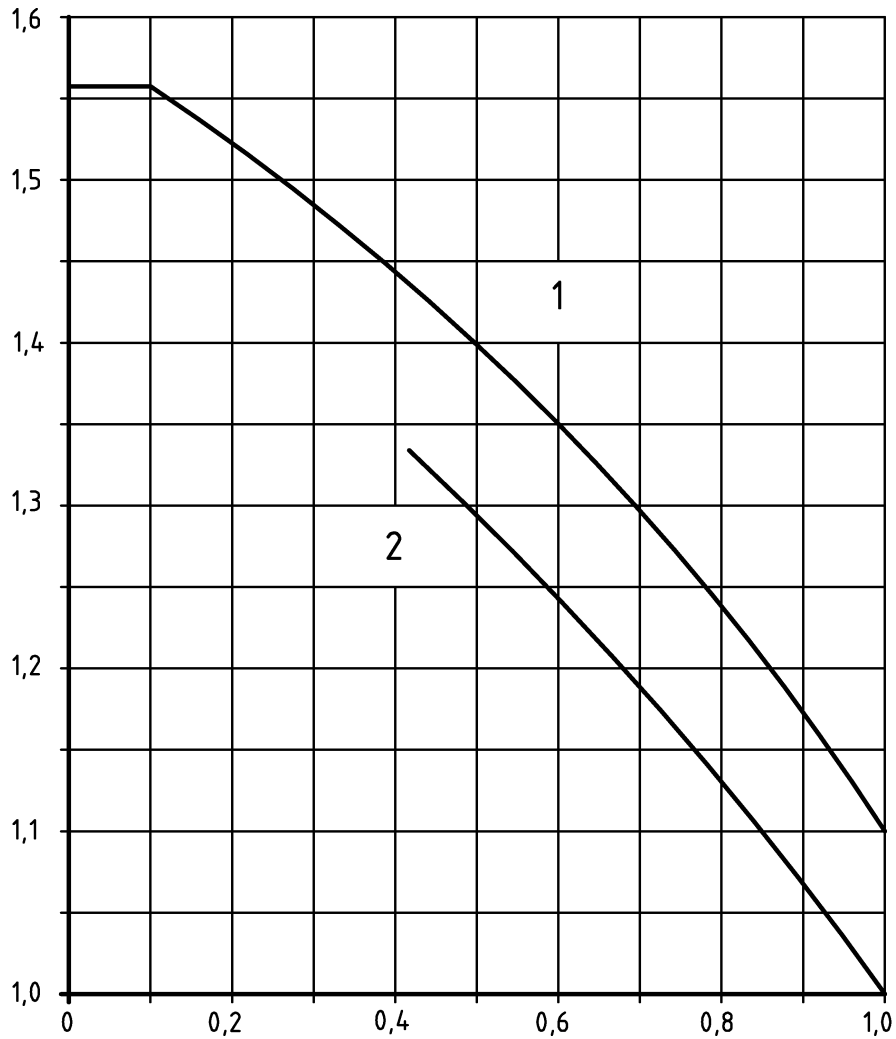
Rectangular plates

f = short side of the rectangular plate

e = long side of the rectangular plate

$$C_e = \begin{cases} \sum_{i=1}^4 A_i \left(\frac{f}{e}\right)^{i-1} & \left| 0,1 < \left(\frac{f}{e}\right) \leq 1,0 \right. \\ 1,562 & \left. \left| 0 < \left(\frac{f}{e}\right) \leq 0,1 \right. \right\}$$

- $A_1 = 1,589\ 146\ 00$
- $A_2 = -0,239\ 349\ 90$
- $A_3 = -0,335\ 179\ 80$
- $A_4 = 0,085\ 211\ 76$

Elliptical plates

f = short side of the elliptical plate

e = long side of the elliptical plate

$$C_A = \begin{cases} \sum_{i=1}^6 A_i \left(\frac{d}{D_i}\right)^{i-1} & \left| 0 < \left(\frac{d}{D_i}\right) \leq 0,8 \right. \\ \sum_{i=1}^6 A_i \left(\frac{d}{f}\right)^{i-1} & \left. \left| 0 < \left(\frac{d}{f}\right) \leq 0,8 \right. \right\}$$

- $A_1 = 1,489\ 146\ 00$
- $A_2 = -0,239\ 349\ 90$
- $A_3 = -0,335\ 179\ 80$
- $A_4 = 0,085\ 211\ 76$

Figure 13 — Design factor C_e for rectangular or elliptical flat plates

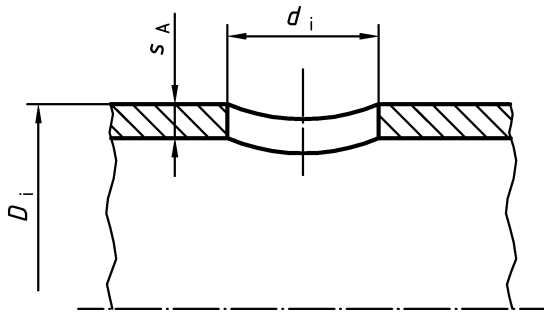

Figure 14 — Increased thickness of a cylindrical shell

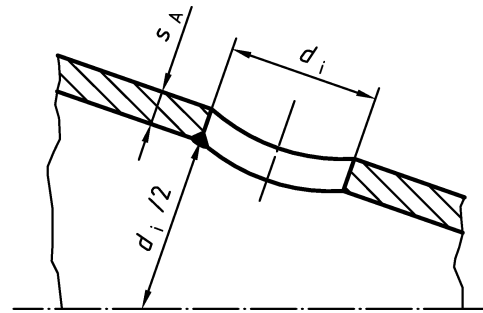

Figure 15 — Increased thickness of a conical shell

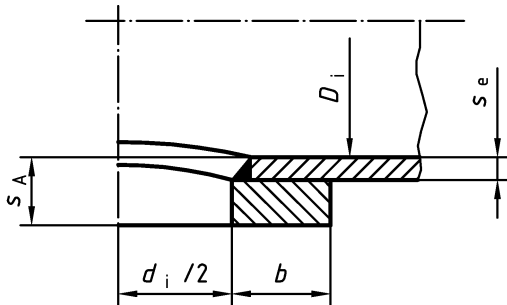

Figure 16 — Set-on reinforcement ring

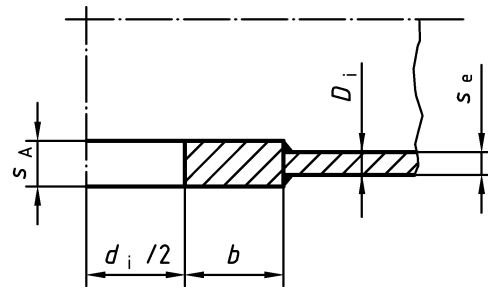

Figure 17 — Set-in reinforcement ring

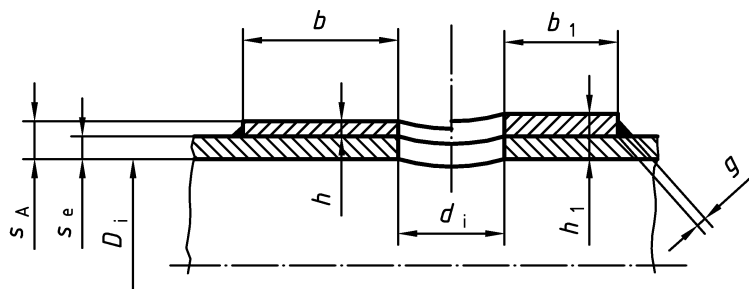

Figure 18 — Pad reinforcement

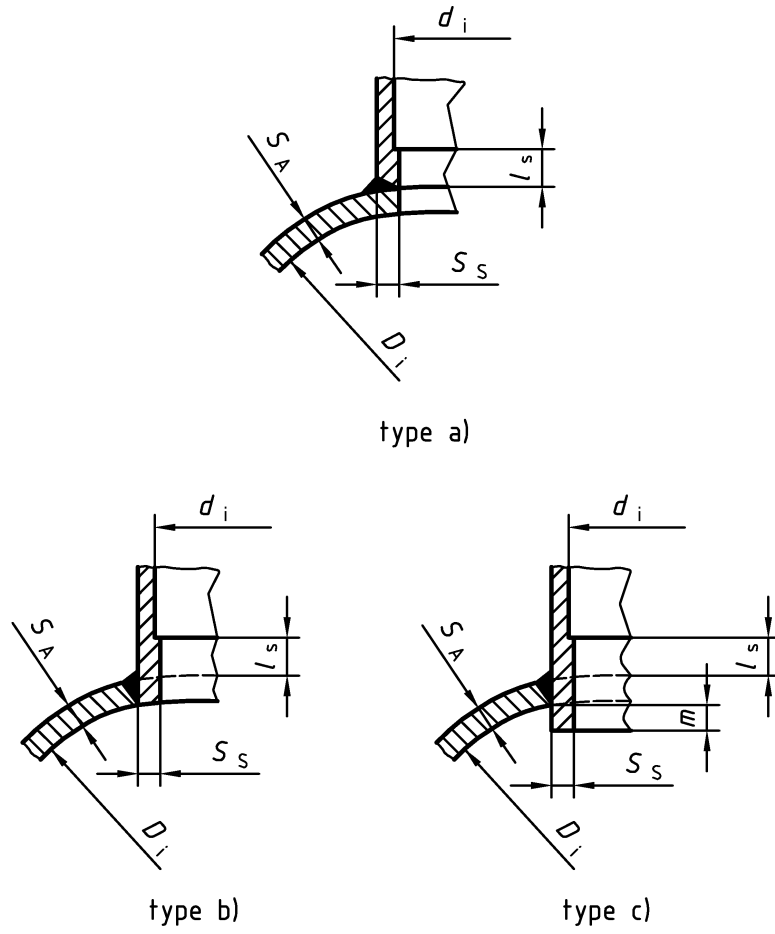

Figure 19 — Nozzle reinforcement

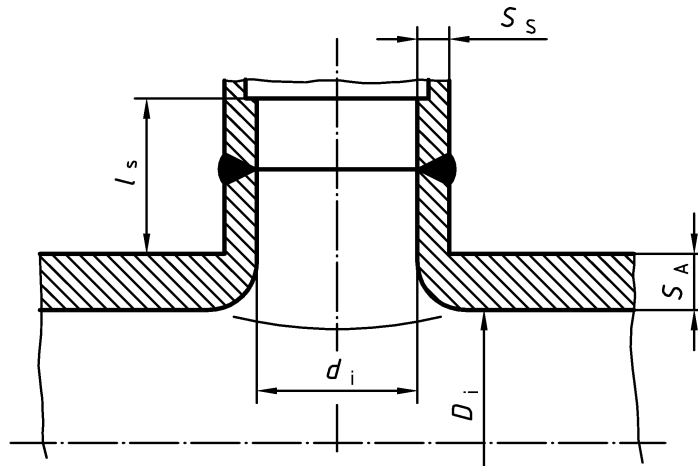

Figure 20 — Necked out opening

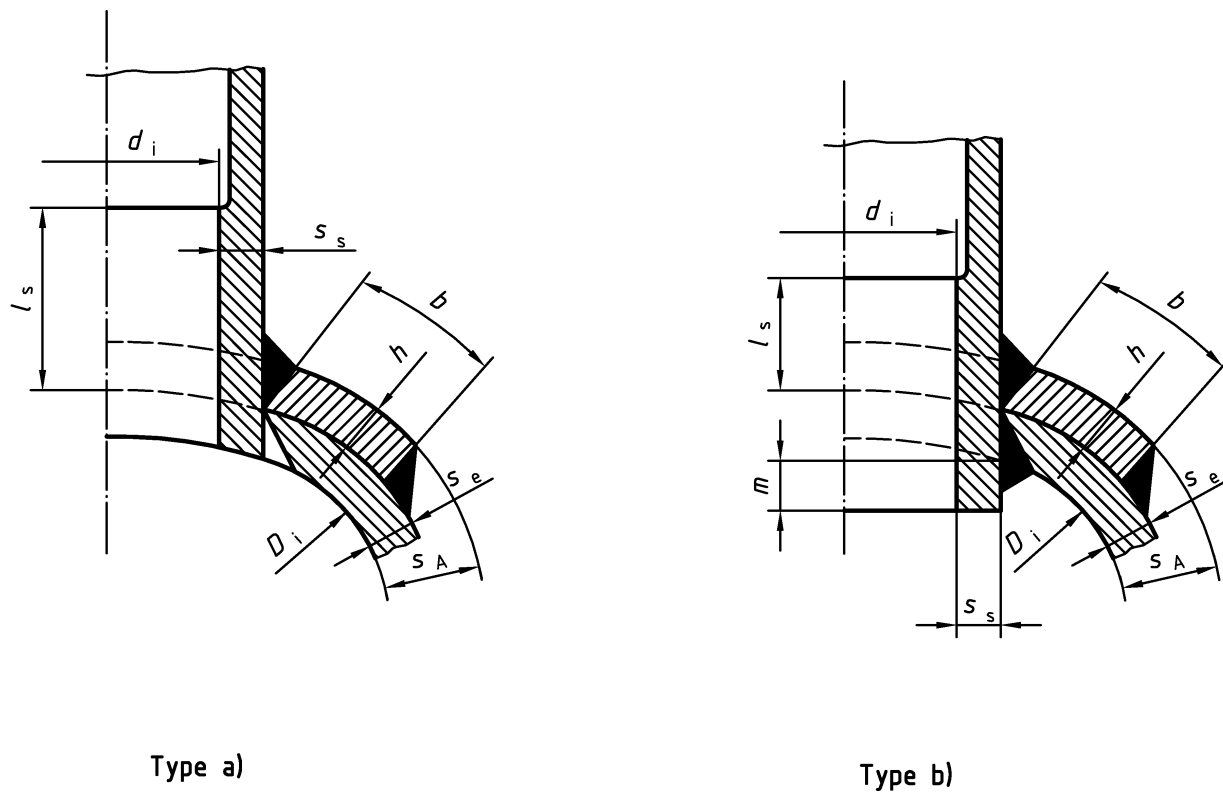

Figure 21 — Pad

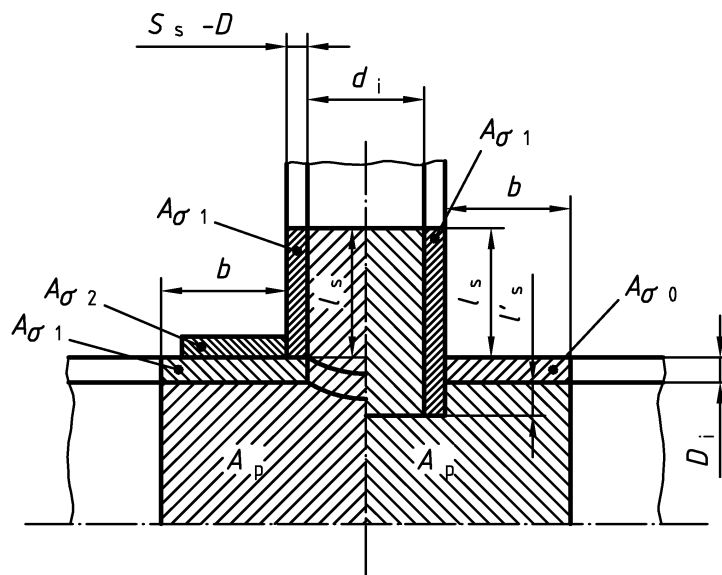

Figure 22 — Calculation scheme for cylindrical shells

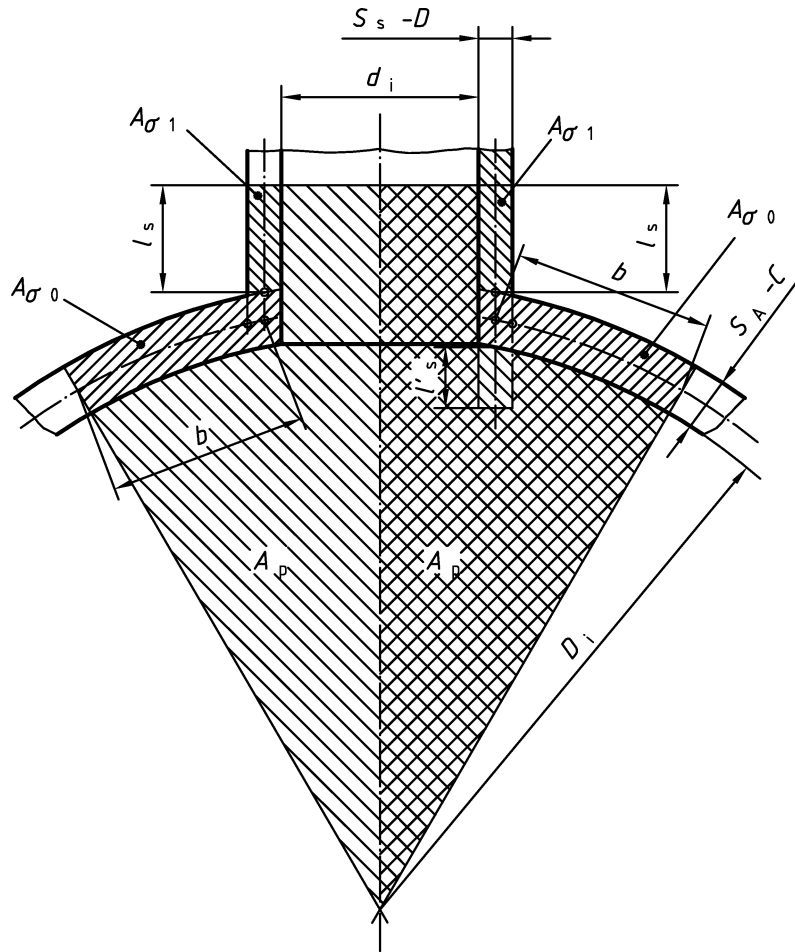

Figure 23 — Calculation scheme for spherical shells

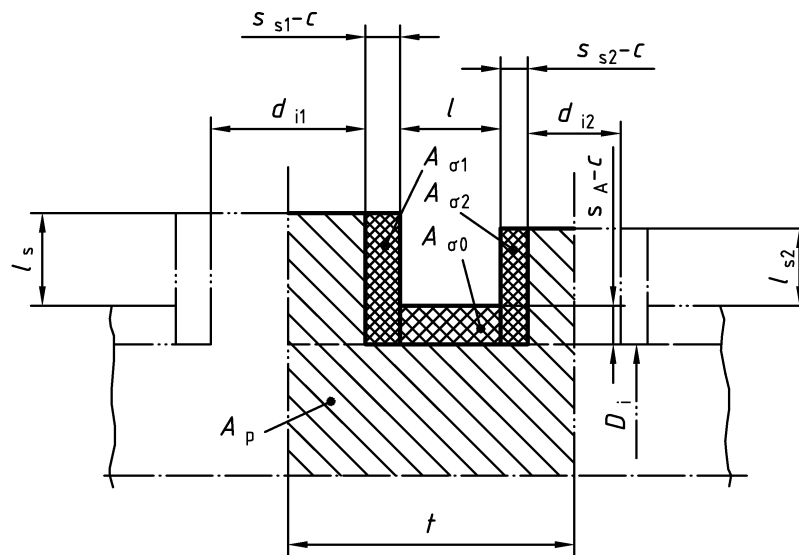
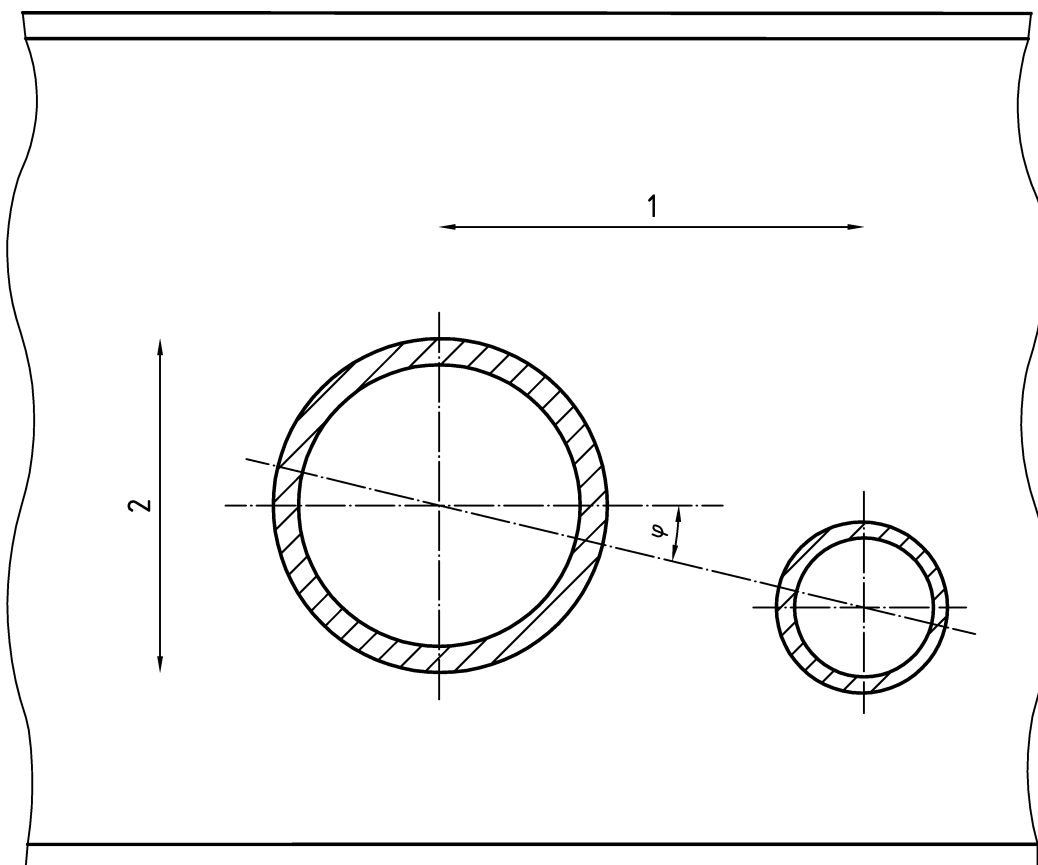

Figure 24 — Calculation scheme for adjacent nozzles in a sphere or in a longitudinal direction of a cylinder



Key

- 1 Longitudinal direction
- 2 Circumferential direction

Figure 25 — Openings between longitudinal and circumferential direction

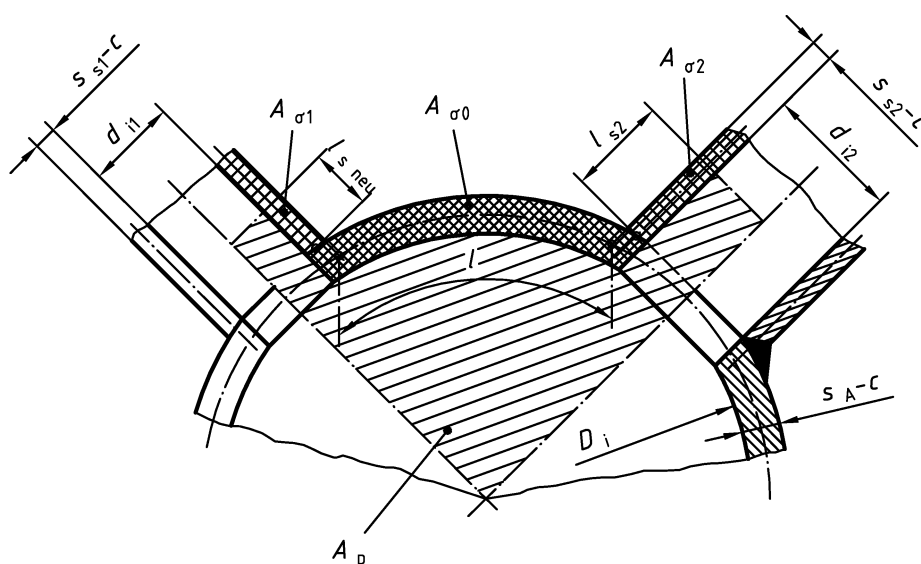

Figure 26 — Calculation scheme for adjacent nozzles in a sphere or in a circumferential direction of a cylinder

5 Fabrication

5.1 General

5.1.1 The manufacturer, or his or her sub-contractor, shall have equipment available to ensure manufacture and testing in accordance with the design.

5.1.2 The manufacturer shall maintain:

- a system of material traceability for pressure bearing parts used in the construction of the inner vessel;
- design dimensions within specified tolerances;
- necessary cleanliness of the inner vessel, associated piping and other equipment which could come in contact with the cryogenic fluid.

5.1.3 The base materials, listed in annex K, additionally specified with the extra requirements given in the main body of this European Standard, are suitable for and may be employed in the manufacture of the cryogenic vessels conforming to EN 13458.

NOTE Materials listed in annex L cannot be used without European approval of pressure equipment materials (EAMs) or Particular material appraisal (PMA).

5.2 Cutting

Material may be cut to size and shape by thermal cutting, machining, cold shearing or other appropriate method. Thermally cut material shall be dressed back by machining or grinding.

5.3 Cold forming

5.3.1 Austenitic stainless steel

Heat treatment after cold forming is not required in any of the following cases:

- 1) for operating temperatures down to $-196\text{ }^{\circ}\text{C}$
 - a) the test certificate for the base material shows an elongation at fracture A_5 of more than 30 % and the cold forming deformation is not more than 15 % or it is demonstrable that the residual elongation is not less than 15 %;
 - b) the cold forming deformation is greater than or equal to 15 % and it is demonstrated that the residual elongation is not less than 15 %;
- 2) for operating temperatures below $-196\text{ }^{\circ}\text{C}$, the test certificate for the base material shows an elongation at fracture A_5 of more than 30 % and the cold forming deformation is not more than 10 %;
- 3) for formed heads, the test certificate for the base material shows an elongation at fracture A_5 :
 - not less than 40 % in the case of wall thicknesses not more than 15 mm at design temperatures down to $-196\text{ }^{\circ}\text{C}$;
 - not less than 45 % in the case of wall thicknesses more than 15 mm at design temperatures down to $-196\text{ }^{\circ}\text{C}$;
 - not less than 50 % at design temperatures below $-196\text{ }^{\circ}\text{C}$.

Where heat treatment is required this shall be carried out in accordance with the material standard.

Cold forming deformation can be calculated according to EN 13445-4.

5.3.2 Ferritic steel

Requirements for post forming heat treatment are:

- a) material for the outer jacket, including cold formed ends with or without joggled joints, does not require post forming heat treatment;
- b) 9 % Ni steel requires post forming heat treatment where cold forming deformation exceeds 5 %. Fully certified quenched and tempered or double normalised and tempered 9 % Ni steel shall be stress relieved at 560 °C to 580 °C. Forming and stress relieving may be performed in several stages. A test piece taken from the parent material that accompanies the formed part through all stages of heat treatment shall be tested after all heat treatment is complete to demonstrate that the material mechanical properties conform to the requirements of the material standard;
- c) for the following ferritic steels used for the inner vessel, post forming heat treatment is not required where the forming deformation is not more than 5 %:
 - 1) nickel alloyed steels suitable for low temperature use;
 - 2) carbon and carbon-manganese steels:
 - where $R_m \leq 530 \text{ N/mm}^2$;
 - or where $530 < R_m \leq 650 \text{ N/mm}^2$ and $R_{0,002} \leq 360 \text{ N/mm}^2$.

When heat treatment is required, suitable heat treatments after cold forming are normalising, normalising (double) plus tempering, quenching plus tempering or solution annealing.

Parameters given by the base material manufacturer in the test certificate shall be taken as an indication or recommendation for heat treatments except that other heat treatments may be applied if the procedure is qualified and the product or a test piece representing the product is tested after forming and heat treatment.

5.3.3 Aluminium or aluminium alloy

Cold formed ends made from aluminium or aluminium alloy do not normally require post forming heat treatment, unless there is a risk of stress corrosion in service. Treatment shall be carried out in accordance with the material standard.

5.4 Hot forming

5.4.1 General

Forming shall be carried out in accordance with a written qualified procedure. The forming procedure shall specify the heating rate, the holding temperature, the temperature range and time for which the forming takes place and shall give details of any heat treatment to be given to the formed part.

5.4.2 Austenitic stainless steel

Material shall be heated uniformly in an appropriate atmosphere without flame impingement, to a temperature not exceeding the recommended hot forming temperature of the material. When forming is carried out after the temperature of the material has fallen below 900 °C the requirements of 5.3.1 shall be complied with.

5.4.3 Ferritic steel

Requirements for post forming heat treatment are:

- a) 9 % Ni steel that is hot formed shall be double normalised and tempered or quenched and tempered in accordance with the material standard to establish the material properties specified therein. Test piece(s) shall be provided and tested in accordance with the material standard;
- b) ferritic steel that is hot formed shall be heat treated in accordance with the material standard to establish the material properties specified therein:
 - air quenched steels shall be tempered subsequently;
 - test pieces shall be provided and tested in accordance with the material standard;
 - for normalised steels a post forming heat treatment is not necessary if the hot forming is done within the temperature range specified in the material standard ; further test pieces are not required.

5.4.4 Aluminium or aluminium alloy

Post forming heat treatment may be omitted if evidence in the form of a procedure qualification can be provided showing that the elongation at fracture A_5 of the formed material is not less than 10 %.

5.5 Manufacturing tolerances

5.5.1 Plate alignment

Except where a tapered transition is provided, misalignment of the surfaces of adjacent plates at welded seams shall be:

- for longitudinal seams, not more than 15 % of the thickness of the thinner plate up to a maximum of 3 mm;
- for circumferential seams, not more than 25 % of the thickness of the thinner plate up to a maximum of 5 mm.

Where a taper is provided between the surfaces, this shall have a slope of not more than 30°. The taper may include the width of the weld, the lower surface being built up with added weld metal if necessary. Where material is removed from a plate to provide a taper, the thickness of either plate shall not be reduced below that required for the design.

The distance between either surface of the thicker plate and the centre line of the thinner plate of tapered seams shall be:

- for longitudinal seams, not less than 35 % of the thickness of the thinner plate;
- for circumferential seams, not less than 25 % of the thickness of the thinner plate.

In no case shall the surface of any plate lie between the centre lines of the two plates.

These requirements are illustrated in Figure 27.

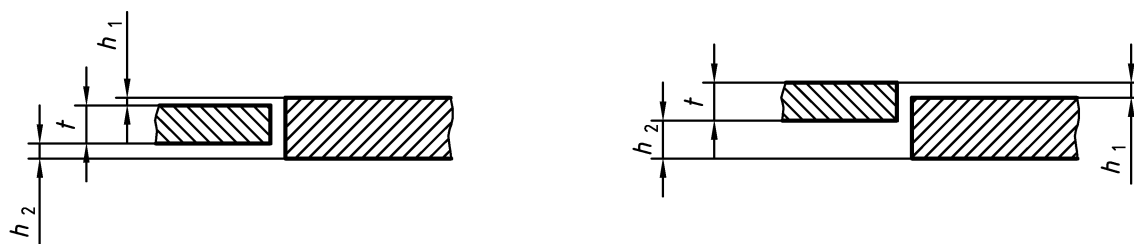
**Key**

h, h_1, h_2 is the surface misalignments

t is the thickness of the thinner plate

e is the distance from the surface of the thicker plate to the centreline of the thinner plate

For longitudinal seams:

$$h_1 \leq 0,15 t \text{ and } h_2 \leq 0,15 t$$

For circumferential seams:

$$h_1 \leq 0,25 t \text{ and } h_2 \leq 0,25 t$$

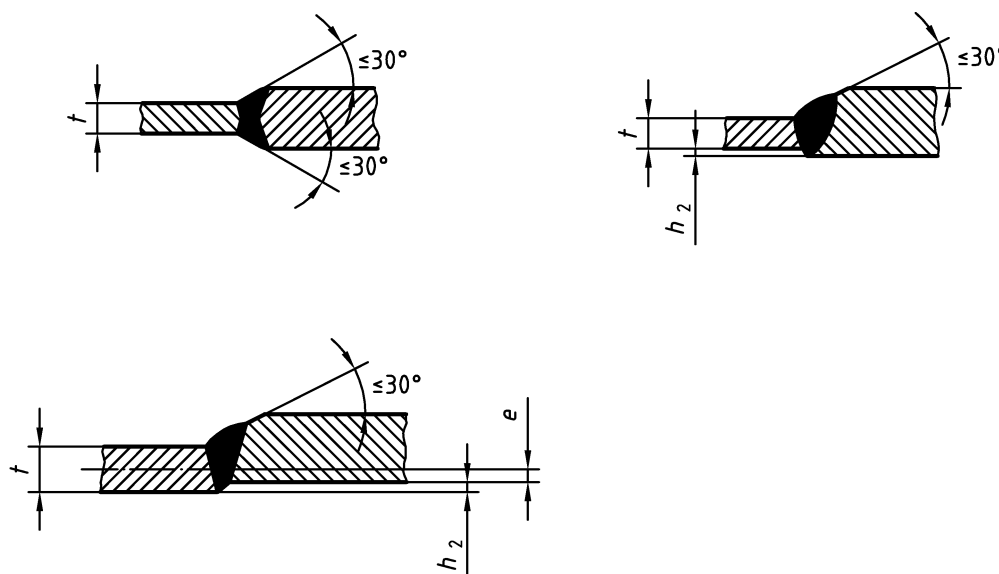
a) — Seam which do not require a taper

For longitudinal seams:

$$h \leq 0,15 t \text{ and}$$

$$e = \frac{t}{2} - h \geq 0,35 t$$

For circumferential seams:

$$h_2 \leq 0,25 t \text{ and}$$

$$e = \frac{t}{2} - h \geq 0,25 t$$

b) — Seams which do require a taper

Figure 27 — Plate alignment

5.5.2 Thickness

The thickness of the vessel shall not be less than the design thickness. This shall be taken as the thickness of the vessel after manufacture and any variations in thickness shall be gradual.

5.5.3 Dished ends

The depth of the dishing, excluding the straight flange, shall not be less than the theoretical depth. The knuckle radius shall not be less than specified and the crown radius shall not be greater than specified. Any variation of the profile shall not be abrupt but shall merge gradually into the specified shape

5.5.4 Cylinders

5.5.4.1 The actual circumference shall not deviate from the circumference calculated from the specified diameter by more than $\pm 1,5\%$.

5.5.4.2 The out of roundness u calculated from the expression:

$$\text{out of roundness } u = \frac{200(D_{\max} - D_{\min})}{D_{\max} + D_{\min}} \quad \text{in \%} \quad (35)$$

shall be not more than the values shown in Table 1.

Table 1 — Permitted out of roundness

Wall thickness to diameter ratio	Permitted out of roundness for	
	internal pressure	external pressure
$s/D \leq 0,01$	2,0 %	1,5 %
$s/D > 0,01$	1,5 %	1,5 %

The determination of the out-of-roundness need not consider the elastic deformation due to the dead-weight of the pressure vessel. At nozzle positions, a greater out-of-roundness may be permitted if it can be justified by calculation or strain gauge measurement. Single dents or knuckles shall be within the tolerances. Dents shall be smooth and their depth which is the deviation from the generatrix of the shell shall not exceed 1 % of their length or 2 % of their width respectively. Greater dents and knuckles are permissible provided they have been proven admissible by calculation or by strain measurements.

Irregularities in profile (checked by a 20° gauge) shall not exceed 2 % of the gauge length. This maximum value may be increased by 25 % if the length of the irregularities does not exceed one quarter of the length of the shell part between two circumferential seams with a maximum of 1 m. Greater irregularities require proof by calculation or strain gauge measurement that the stresses are permissible.

Furthermore, where irregularity in the profile occurs at the welded seam and is associated with "flats" adjacent to the weld the irregularity in profile or "peaking" shall not exceed the values given in Table 2.

A conservative method of measurement (covering peaking and ovality) shall be by means of a 20° profile gauge (or template).

The use of such a profile gauge is illustrated in Figure 28. Two readings shall be taken, P_1 and P_2 on each side of the seam, at any particular location, the maximum peaking is taken as being equivalent to $0,25 (P_1 + P_2)$.

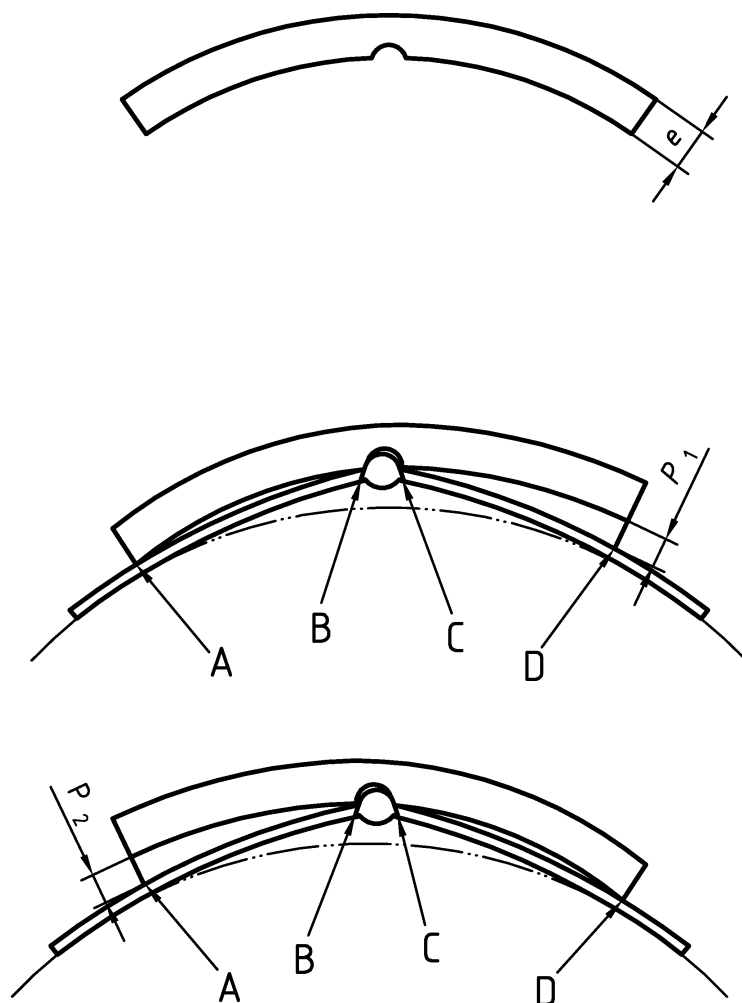

Figure 28 — Gauge details

Measurements should be taken at approximately 250 mm intervals on longitudinal seams to determine the location with the maximum peaking value. Use of other types of gauges such as bridge gauges or needle gauges are not prohibited. The maximum peaking value permitted is given in Table 2.

Table 2 — Maximum permitted peaking

Dimensions in millimetres

Vessel ratio wall thickness s to diameter D	Maximum permitted peaking
$s/D \leq 0,025$	5
$s/D > 0,025$	10

For all ratios a maximum permitted peaking is e .

For cylinders subject to external pressure and where the circumference has a flattened portion, it shall be demonstrated that the shell has sufficient strength to avoid plastic deformation where the depth of flattening is more than 0,4 % of the outside diameter of the cylinder. The depth of flattening shall be measured as a deviation from the normal curvature or from the line of the cylindrical shell. Adequate strength may be determined by calculation in accordance with formula (6) of 4.3.6.2.5, using a value of u determined as follows:

$$u = \frac{400}{D_a} q \quad (36)$$

where

q is the depth of flattening, in millimetres;

D_a is the external diameter of the cylinder, in millimetres.

5.5.4.3 Departure of the cylinder axis from a straight line shall be not more than 0,5 % of the cylindrical length, except where required by the design.

5.6 Welding

5.6.1 General

This European standard requires that the welding method be appropriate and be carried out by qualified welders and/or operators, that the materials be compatible and that there is verification by a welding procedure test.

5.6.2 Qualification

Welding procedures shall be approved in accordance with EN 288-3, EN 288-4 or EN 288-8 as applicable.

Welders and welding operators shall be qualified in accordance with EN 287-1 or EN 287-2 or EN 1418 as applicable.

5.6.3 Temporary attachments

Temporary attachments welded to pressure bearing parts shall be kept to a practical minimum.

Temporary attachments welded directly to pressure bearing parts shall be compatible with the immediately adjacent material.

It is permissible to weld dissimilar metal attachments to intermediate components, such as pads, which are connected permanently to the pressure containing part. Compatible welding materials shall be used for dissimilar metal joints.

Temporary attachments shall be removed from the inner vessel prior to the first pressurisation. The removal technique shall avoid impairing the integrity of the inner vessel and shall be by chipping or grinding. Any rectification necessary by welding of damaged regions shall be undertaken in accordance with an approved welding procedure.

The area of the inner vessel from where the temporary attachments have been removed shall be dressed smooth and examined by appropriate non-destructive testing.

Any attachments on the outer jackets may be removed by thermal cutting as well as by the methods described above.

5.6.4 Welded joints

5.6.4.1 Some specific weld details appropriate to vessels conforming to EN 13458 are given in annex F. These details show sound and currently accepted practice. It is not intended that these are mandatory nor should they restrict the development of welding technology in any way.

The manufacturer, in selecting an appropriate weld detail, shall consider:

— the method of manufacture;

- the service conditions;
- the ability to carry out necessary non-destructive testing.

Weld details may be used provided their suitability is proven by procedure approval according to EN 288-3, EN 288-4 or EN 288-8 as applicable.

To avoid sub-standard welding of ferritic steels excess residual magnetism shall be avoided.

5.6.4.2 Where any part of a vessel is made in two or more courses, the longitudinal weld seams of adjacent courses shall be staggered. A minimum of 100 mm is recommended.

5.6.4.3 As the mechanical characteristics of work-hardened austenitic stainless steels can be adversely affected if the material is not welded properly, the additional requirements below shall be applied:

- the heat input during welding shall be not more than 1,5 kJ/mm per bead to be verified in the procedure qualification test ;
- the material shall cool down to a temperature of not more than 200 °C between passes;
- the material shall not be heat treated after welding;

See also B.2.7, B.2.8, B.2.10 and B.2.11.

5.7 Non-welded permanent joints

Where non-welded joints are made between metallic materials and/or non-metallic materials, procedures shall be established in a manner similar to that used in establishing welding procedures, and these procedures shall be followed for all joints. Similarly, operators shall be qualified in such procedures and only qualified personnel shall then carry out these procedures.

Brazing procedures and brazing approvals can be found in EN 13133 and EN 13134.

6 Inspection and testing

6.1 Quality plan

A quality plan shall include as a minimum, the inspection and testing stages listed in 6.1.1.

6.1.1 Inspection stages during manufacture of an inner vessel

The following inspection stages shall be conducted during the manufacture of an inner vessel:

- verification of material test certificates and correlation with materials;
- approval of weld procedure qualification records;
- approval of welders qualification records;
- examination of material cut edges;
- examination of set up of seams for welding including dimensional check;
- examination of weld preparations, tack welds;
- visual examination of welds;

- verification of non-destructive testing;
- testing production control test plates for welds and, where required, for formed parts after heat treatment;
- verification of cleaning of inside surface of vessel;
- examination of completed vessel including dimensional check;
- pressure test and where necessary record permanent set.

6.1.2 Additional inspection stages during manufacture of a static cryogenic vessel

The following inspection stages shall be conducted during the manufacture of a static cryogenic vessels:

- verification of cleanliness and dryness of static cryogenic vessel;
- visual examination of welds not covered by 6.1.1;
- ensure integrity of vacuum;
- leak test of external piping;
- check documentation and installation of pressure relief device(s);
- check installation of vacuum space relief device;
- check name plate and any other specified markings;
- examination of completed vessel including dimensional check.

6.2 Production control test plates

6.2.1 Requirements

Production control test plates shall be produced and tested for the inner vessel as follows:

- a) one test plate per vessel for each welding procedure on longitudinal joints;
- b) after 10 sequential test plates to the same procedure have successfully passed the tests, testing may be reduced to one test plate per 50 m of longitudinal joint for 9 % Ni and ferritic steels and to one test plate per 100 m for other metals.

Production control test plates are not required for the outer jacket.

The results of the tests shall be as follows:

- weld tensile test (T): R_{eT} , R_m and A_5 of the test specimens shall normally not be less than the corresponding specified minimum values for the parent metal, or the agreed values of the welding procedure approved ;
- impact test (IW, IH): this test shall be performed in accordance with EN 1252-1 or EN 1252-2;
- bend test (BF, BR, BS): the testing and the test requirements shall comply with 7.4.2 of EN 288-3:1992 for steels and with 7.4.2 of EN 288-4:1992 for aluminium and its alloys ;
- macro etch (Ma): the macro etch shall show sound build-up of beads and sound penetration.

6.2.2 Extent of testing

The number and type of test specimens to be taken from the test plate is dependent on material and thickness and shall be in accordance with the requirements in Tables 4 and 5 for the particular material and thickness applicable.

NOTE The symbols for Tables 4 and 5 are given in Table 3.

The test plate shall be of sufficient size to allow for the required specimens including an allowance for retests.

Prior to cutting the test piece non destructive testing of the test plate may be applied in order that the test specimens are taken from sound areas.

Table 3 — Test specimens

Designation	Symbol
Face bend test to EN 910:1996	BF
Root bend test to EN 910:1996	BR
Side bend test to EN 910:1996	BS
Tensile test to EN 895:1995	T
Impact test; weld deposit to EN 875:1995	IW
Impact test, HAZ to EN 875:1995	IH
Macro etch	Ma

Table 4 — Testing of production test plates for steels

Group	e in mm	Test specimens
Fine grain steels normalised or thermo mechanically treated	$e \leq 12$	1 BF, 1 BR, 1 T, 1 Ma
	$12 < e \leq 35$	3 IW, 3 IH, 1 T, 1 Ma
Ni steels up to 9% Ni	$e \leq 12$	1 BF, 1 BR, 1 T, 1 Ma
	$12 < e$	3 IW, 3 IH, 1 T, 1 Ma
Austenitic stainless steels	$e \leq 12$	1 BF, 1 BR, 1 T, 1 Ma
	$12 < e$	3 IW, 1 T, 1 Ma

Table 5 — Testing of production test plates for aluminium

Group	e in mm	Test specimens
Pure aluminium and aluminium with up to 1.5% impurities or alloy content	$e \leq 12$	1 BF, 1 BR, 1 T, 1 Ma
	$12 < e$	2 BS, 1 T, 1 Ma

6.3 Non-destructive testing

6.3.1 General

Non-destructive testing personnel shall be qualified for the duties according to EN 473.

X-ray examination shall be carried out in accordance with EN 1435 or ISO 1106-1. Radioscopy may also be used and shall be carried out in accordance with EN 13068-3.

Non-destructive testing for welding imperfections is not required on the outer jacket of static cryogenic vessels.

6.3.2 Extent of examination for surface imperfections

Visual examination (if necessary aided by x5 lens) shall be carried out on all weld deposits. If any doubt arises, this examination shall be supplemented by surface crack detection.

Arc strike contact points and areas from which temporary attachments have been removed shall be ground smooth and subjected to surface crack detection.

6.3.3 Extent of examination for volumetric imperfections

Examination of the inner vessel for volumetric imperfections shall be by radiographic examination unless a special case is made to justify ultra-sonic or other methods. The extent of examination of main seams on the inner vessel shall be in accordance with Table 6.

When hemispherical ends without a straight flange are welded together or to a cylinder, the weld shall be tested as a longitudinal weld. Any welds within an hemispherical end shall also be tested as longitudinal welds.

Table 6 — Extent of radiographic examination for welded seams

Weld joint factor <i>v</i>	Radiographic examination		
	Longitudinal seams	T junctions	Circumferential seams
1,0	100 % *	100 %	25 % *
0,85	2 %	10 % or minimum of 1 joint per vessel	2 %

NOTE 1 When a butt weld occurs less than 3 times the weld thickness (min. 50 mm) from a nozzle cut out, it is necessary to take additional radiographic film(s) local to the nozzle where the original film(s) have not included this location.

NOTE 2 The level of radiographic examination marked with an asterisk (*) can be reduced to 10 % of each seam of each vessel if 25 vessels have been successfully built using the same welding procedure, provided :

- the welding procedure is unaltered;
- the welding experience has been retained in the workshop;
- the testing methods are the same;
- the results of non-destructive testing have not revealed any unacceptable systematic defects.

NOTE 3 For additional requirements for 9 % Ni steel use annex B.

NOTE 4 For corner joints of cones and areas of high bending stress treat the circumferential seam as a longitudinal seam with joint factor 1.

NOTE 5 Additional testing can be required when pneumatic proof testing is used.

NOTE 6 The 2 % level of radiographic examination can be carried out on a batch of vessels. The number of vessels included in a test batch should not be more than 5. The 2 % should not be included in the film length of the T junctions examined.

6.3.4 Acceptance levels

6.3.4.1 Acceptance levels for surface imperfections

Table 7 shows the acceptance criteria for surface imperfections.

Table 7 — Acceptance levels for surface imperfections

Imperfection	EN ISO 6520-1:1998 reference	Limit for acceptable imperfection
Lack of penetration	402	Not permitted
Undercut	5011	Where the thickness is less than 3 mm no visible undercut is permitted. Where the thickness is not less than 3 mm, slight and intermittent undercut is acceptable, provided that it is not sharp and is not more than 0,5 mm.
Shrinkage groove	5013	As undercut
Root concavity	515	As undercut
Excessive penetration	504	Where the thickness is less than 5 mm, excessive penetration shall be not more than 2 mm. Where the thickness is not less than 5 mm, excessive penetration shall not be more than 3 mm.
Excess weld material	502	Where the thickness is less than 5 mm, excess weld metal shall not be greater than 2 mm and the weld shall blend smoothly. Where the thickness is 5 mm or greater, the maximum excess weld metal shall not exceed 3 mm and the weld shall blend smoothly.
Irregular surface	514	Reinforcement to be of continuous and regular shape with complete filling of groove.
Sagging	509	
Incompletely filled groove	511	
Irregular width	513	
Poor restart	517	
Overlap	506	Not permitted
Linear misalignment	507	See 5.5.1
Arc strike	601	Grind smooth, acceptable subject to thickness measurement and surface crack detection test.
Spatter	602	
Tungsten spatter	6021	
Torn surface	603	
Grinding mark	604	
Chipping mark	605	
Surface cracks		Not permitted

6.3.4.2 Acceptance levels for internal volumetric imperfections

Table 8 shows the acceptance criteria for internal volumetric imperfections detected by radiographic examination.

Table 8 — Acceptance levels for internal volumetric imperfections

Imperfection	EN ISO 6520-1:1998 reference	Limit for acceptable imperfection
Cracks and lack of sidewall fusion	4011	Not permitted
Incomplete root fusion	4013	Not permitted
Flat root concavity		Acceptable
Inclusions (including oxide in aluminium welds). Strings of pores, worm holes parallel to the surface and strings of tungsten.	303 304 2014 2015	30 % of thickness The maximum length shall be the greater of 7 mm or 2/3 t.
Interrun fusion defects and root defects in multipass weld	4012	As inclusions
Multiple in-line inclusions		Collectively in any radiographed length equal to six times the material thickness, the total length of inclusion shall not be greater than the material thickness.
Area of general porosity visible on a film		Acceptable if less than 2 % of projected area of weld
Individual pores	2011	Acceptable if diameter is less than 25 % of the thickness with a maximum of 4 mm
Worm holes perpendicular to the surface	2021	Where the thickness is less than 10 mm, worm holes are not permitted. Where the thickness is not less than 10 mm, isolated examples are acceptable provided the depth is estimated to be not more than 30 % of the thickness.
Tungsten inclusions	3041	Where the thickness is less than 12 mm, tungsten inclusions are acceptable provided the length is not more than 3 mm. Where the thickness is not less than 12 mm, tungsten inclusions are acceptable provided the length is not more than 25 % of the thickness.

6.3.4.3 Extent of examination of non-welded joints

Where non-welded joints are used between metallic materials and/or non-metallic materials, the quality plan referred to in 6.1 shall include reference to an adequate technical specification.

This technical specification shall include the description of the requirements for inspection and testing, together with the criteria necessary to allow for the repair of any imperfections.

6.4 Rectification

6.4.1 General

Although unacceptable volumetric or surface imperfections may be repaired by removing the imperfections and rewelding, 100 % of all repaired welds shall be examined to the original acceptance standards.

6.4.2 Manually welded seams

When repairs to welds are carried out as a result of radiographic examination which is less than 100 %, an additional radiographic film (200 mm) shall be taken either side of the repair to ensure the imperfection was isolated and not systematic. Where the imperfections are systematic and characterised by recurrence of the same imperfection, the extent of examination shall be increased to 100 % until the cause of the imperfections has been found and eliminated.

6.4.3 Seams produced using automatic welding processes

If any unacceptable imperfections are found by radiographic examination, all main weld seams shall be 100 % radiographically examined on all vessels produced with the same welding machine and welding procedure from the start of the production period or from the last accepted non-destructive test.

6.5 Pressure testing

6.5.1 Every inner vessel shall be subjected to a pressure test and its leak tightness shall be demonstrated. This leak tightness may be demonstrated during the establishment of the vacuum or by a separate leak test at pressures up to the design pressure.

The test pressure shall not be less than the higher of:

1,43 ($p_s + 1$) bar hydrostatic or 1,25 ($p_s + 1$) bar pneumatic

$1,25(p_s + p_L + 1) \frac{K_{20}}{K_{design}}$, in bar, considered for each element of the vessel e.g. shell, courses, head, etc.

Where the test is carried out hydraulically the pressure shall be raised gradually to the test pressure holding it there for 30 min. Then the pressure shall be reduced to the design pressure so that a visual examination of all surfaces and joints can be made. The vessel shall not show any sign of gross plastic deformation or leakage. The test may be carried out pneumatically on a similar basis. As pneumatic testing employs substantially greater stored energy than hydraulic testing, it shall normally only be carried out where adequate facilities and procedures are employed to assure the safety of inspectors, employees and the public.

6.5.2 Vessels which have been repaired subsequent to the pressure test shall be re-subjected to the specified pressure test after completion of the repairs.

6.5.3 Where austenitic stainless steel comes into contact with water the chloride content of the water and time of exposure shall be controlled so as to avoid stress corrosion cracking.

6.5.4 The piping system external to the pressure vessel shall be subjected to a pressure test at a pressure not less than 1,1 times the design pressure (4.2.3.7.e) for the appropriate section of pipework. It is not necessary to strength test mechanical joints and fittings that have demonstrated satisfactory in-service experience.

Annex A (normative)

Elastic stress analysis

A.1 General

This annex provides rules to be followed if an elastic stress analysis is used to evaluate components of a static cryogenic vessel for operating conditions. The loads to be considered are those defined in 4.2.3.

A.4 and A.5 give alternative criteria for demonstrating the acceptability of design on the basis of elastic analysis. The criteria in A.5 apply only to local stresses in the vicinity of attachments, supports, nozzles, etc.

The calculated stresses in the area under consideration are grouped into the following stress categories:

- general primary membrane stress;
- local primary membrane stress;
- primary bending stress;
- secondary stress.

Stress intensities f_m , f_L , f_b , and f_g can be determined from the principle stresses f_1 , f_2 and f_3 in each category using the maximum shear stress theory of failure, see A.2.1.

The stress intensities determined in this way shall be less than the allowable values given in A.3 and A.4 or A.5.

Peak stresses need not be considered as they are only relevant when evaluating designs for cyclic service. Static cryogenic vessel within the scope of this standard are not considered to be in cyclic service.

Figure A.1 and Table A.1 have been included as guidance, where A.4 is used for evaluation, in establishing stress categories for some typical cases and stress intensity limits for combinations of stress categories. There will be instances when references to definitions of stresses will be necessary to classify a specific stress condition to a stress category. A.4.5 explains the reason for separating them into two categories "general" and "secondary" in the case of thermal stresses.

A.2 Terminology

A.2.1 Stress intensity

The stress intensity is twice the maximum shear stress, i.e. the difference between the algebraically largest principal stress and the algebraically smallest principal stress at a given point. Tension stresses are considered positive and compression stresses are considered negative.

The principal stresses f_1 and f_2 acting tangentially to the surface at the point under consideration should be calculated from the following equations:

$$f_1 = 0,5 \cdot \left(\sigma_1 + \sigma_2 + \sqrt{(\sigma_1 - \sigma_2)^2 + 4 \cdot \tau^2} \right)$$

$$f_2 = 0,5 \cdot \left(\sigma_1 + \sigma_2 - \sqrt{(\sigma_1 - \sigma_2)^2 + 4 \cdot \tau^2} \right)$$

where

σ_1 is the circumferential stress;

σ_2 is the meridional stress (longitudinal in a cylindrical shell);

τ is the shear stress.

A.2.2 Gross structural discontinuity

A gross structural discontinuity is a source of stress or strain intensification that affects a relatively large portion of a structure and has a significant effect on the overall stress or strain pattern or on the structure as a whole.

Examples of gross structural discontinuities are:

EXAMPLE 1 End to shell junctions

EXAMPLE 2 Junctions between shells of different diameters or thicknesses

EXAMPLE 3 Nozzles

A.2.3 Local structural discontinuity

A local structural discontinuity is a source of stress or strain intensification that affects a relatively small volume of material and does not have a significant effect on the overall stress or strain pattern or on the structure as a whole.

EXAMPLE 1 Small fillet radii

EXAMPLE 2 Small attachments

EXAMPLE 3 Partial penetration welds

A.2.4 Normal stress

The normal stress is the component of stress normal to the plane of reference; this is also referred to as direct stress.

Usually the distribution of normal stress is not uniform through the thickness of a part, so this stress is considered to be made up in turn of two components one of which is uniformly distributed and equal to the average value of stress across the thickness of the section under consideration, and the other of which varies with the location across the thickness.

A.2.5 Shear stress

The shear stress is the component of stress acting in the plane of reference.

A.2.6 Membrane stress

The membrane stress is the component of stress that is uniformly distributed and equal to the average value of stress across the thickness of the section under consideration.

A.2.7 Primary stress

A primary stress is a stress produced by mechanical loadings only and so distributed in the structure that no redistribution of load occurs as a result of yielding. A normal stress, or a shear stress developed by the imposed loading, is necessary to satisfy the simple laws of equilibrium of external and internal forces and moments. The basic characteristic of this stress is that it is not self-limiting. Primary stresses that considerably exceed the yield strength will result in failure, or at least in gross distortion. A thermal stress is not classified as a primary stress. Primary stress is divided into "general" and "local" categories. The local primary stress is defined in A.2.8.

Examples of general primary stress are:

EXAMPLE 1 The stress in a cylindrical or a spherical shell due to internal pressure or to distributed live loads.

EXAMPLE 2 The bending stress in the central portion of a flat head due to pressure.

A.2.8 Primary local membrane stress

Cases arise in which a membrane stress produced by pressure or other mechanical loading and associated with a primary and/or a discontinuity effect produces excessive distortion in the transfer of load to other portions of the structure.

Conservatism requires that such a stress be classified as a primary local membrane stress even though it has some characteristics of a secondary stress. A stressed region may be considered as local if the distance over which the stress intensity exceeds 110 % of the allowable general primary membrane stress does not extend in the meridional direction more than $0,5\sqrt{Rs}$ and if it is not closer in the meridional direction than $2,5\sqrt{Rs}$ to another region where the limits of general primary membrane stress are exceeded. Where R and s are respectively the radius and thickness of the component.

An example of a primary local stress is the membrane stress in a shell produced by external load and moment at a permanent support or at a nozzle connection.

A.2.9 Secondary stress

A secondary stress is a normal stress or a shear stress developed by the constraint of adjacent parts or by self-constraint of a structure. The basic characteristic of a secondary stress is that it is self-limiting. Local yielding and minor distortions can satisfy the conditions that cause the stress to occur and failure from one application of the stress is not be expected.

An example of secondary stress is the bending stress at a gross structural discontinuity.

A.2.10 Peak stress

The basic characteristic of a peak stress is that it does not cause any noticeable distortion and is objectionable only as a possible source of a fatigue crack. A stress that is not highly localised falls into this category if it is of a type that cannot cause noticeable distortion.

EXAMPLE 1 The surface stresses in the wall of a vessel or pipe produced by thermal shock

EXAMPLE 2 The stress at a local structural discontinuity

A.3 Limit for longitudinal compressive general membrane stress

The longitudinal compressive stress shall not exceed $0,93 \Delta K$ for ferritic steels and $0,73 \Delta K$ for austenitic stainless steel and aluminium alloys. Where Δ is obtained from Figure A.2 or A.3 in terms of $p_e / p_{y,ss}$ and where:

$$p_e = \frac{1,21E_s^2}{R^2}$$

and

$$p_{yss} = \frac{1,86K_s}{R} \quad \text{for ferritic steel}$$

and

$$p_{yss} = \frac{1,46K_s}{R} \quad \text{for austenitic stainless steel and aluminium alloys}$$

A.4 Stress categories and stress limits for general application

A.4.1 General

A calculated stress depending upon the type of loading and/or the distribution of such stress will fall within one of the five basic stress categories defined in A.4.2 to A.4.6. For each category, a stress intensity value is derived for a specific condition of design. To satisfy the analysis this stress intensity shall fall within the limit detailed for each category.

A.4.2 General primary membrane stress category

The stresses falling within the general primary membrane stress category are those defined as general primary stresses in A.2.7 and are produced by pressure and other mechanical loads, but excluding all secondary and peak stresses. The value of the membrane stress intensity is obtained by averaging these stresses across the thickness of the section under consideration. The limiting value of this stress intensity f_m is the allowable stress value $2K/3$.

A.4.3 Local primary membrane stress category

The stresses falling within the local primary membrane stress category are those defined in A.2.8 and are produced by pressure and other mechanical loads, but excluding all thermal and peak stresses. The stress intensity f_L is the average value of these stresses across the thickness of the section under consideration and is limited to K .

A.4.4 General or local primary membrane plus primary bending stress category

The stresses falling within the general or local primary membrane plus primary bending stress category are those defined in A.2.7 but the stress intensity value f_b , $(f_m + f_b)$ or $(f_L + f_b)$ is the highest value of those stresses acting across the section under consideration excluding secondary and peak stresses. f_b is the primary bending stress intensity, which means the component of primary stress proportional to the distance from centroid of solid section. The stress intensity f_b , $(f_m + f_b)$ or $(f_L + f_b)$ is not to exceed K .

A.4.5 Primary plus secondary stress category

The stresses falling within the primary plus secondary stress category are those defined in A.2.7 plus those of A.2.9 produced by pressure, other mechanical loads and general thermal effects. The effects of gross structural discontinuities, but not of local structural discontinuities (stress concentrations), should be included. The stress intensity value $(f_m + f_b + f_g)$ or $(f_L + f_b + f_g)$ is the highest value of these stresses acting across the section under consideration and shall be limited to $2K$.

A.4.6 Thermal stress

Thermal stress is a self-balancing stress produced by a non-uniform distribution of temperature or by differing thermal coefficients of expansion. Thermal stress is developed in a solid body whenever a volume of material is prevented from assuming the size and shape that it normally should under a change in temperature.

For the purpose of establishing allowable stresses, the following two types of thermal stress are recognised, depending on the volume or area in which distortion takes place:

- a) general thermal stress is associated with distortion of the structure in which it occurs. If a stress of this type neglecting stress concentrations, exceeds $2 K$ the elastic analysis may be invalid and successive thermal cycles may produce incremental distortion. This type is therefore classified as secondary stress in Table A.1 and Figure A.1;

Examples of general thermal stress are:

EXAMPLE 1 The stress produced by an axial thermal gradient in a cylindrical shell.

EXAMPLE 2 The stress produced by the temperature difference between a nozzle and the shell to which it is attached.

- b) local thermal stress is associated with almost complete suppression of the differential expansion and thus produces no significant distortion. Such stresses are only considered from the fatigue standpoint.

EXAMPLE A small cold spot in a vessel wall.

A.5 Specific criteria, stress categories and stress limits for limited application

A.5.1 General

The criteria and stress limits for particular stress categories for elastically calculated stresses adjacent to attachments and supports and to nozzles and openings which are subject to the combined effects of pressure and externally applied loads are specified in A.5.2 to A.5.4.

The minimum separation in the meridional direction between adjacent loaded attachments, pads, nozzles or openings or other stress concentrating features shall not be less than $2,5\sqrt{R_s}$.

R and s are respectively the radius and thickness of the component. The criteria of A.2.8 are not applicable to this section.

If design acceptability is demonstrated by A.5 then the use of A.4 is not required.

A.5.2 Attachments and supports

The dimension in the circumferential direction of the loaded area shall not exceed one third of the shell circumference. The stresses adjacent to the loaded area due to pressure acting in the shell may be taken as the shell pressure stresses without any concentrating effects due to the attachment.

Under the design combined load the following stress limits apply:

- the primary membrane stress intensity shall not exceed $0,8 K$;
- the stress intensity due to the sum of primary membrane and primary bending stresses shall not exceed $4 K/3$;
- the stress intensity due to the sum of primary membrane stresses, primary bending stresses and thermal stresses shall not exceed $2 K$.

A.5.3 Nozzles and openings

The nozzle or opening shall be reinforced in accordance with 4.3.6.7.

Under the design combined load the following stress limits apply:

- the primary membrane stress intensity should not exceed $0,8 K$;
- the stress intensity due to the sum of primary membrane stresses and primary bending stresses shall not exceed $1,5 K$;
- the stress intensity due to the sum of primary membrane stresses, primary bending stresses and thermal stresses shall not exceed $2 K$.

A.5.4 Additional stress limits

Where significant compressive membrane stresses are present the possibility of buckling shall be investigated and the design modified if necessary (see A.3). In cases where the external load is highly concentrated, an acceptable procedure would be to limit the sum of membrane and bending stresses (total compressive stress) in any direction at the point to $0,9 K$.

Where shear stress is present alone, it shall not exceed $K/3$. The maximum permissible bearing stresses should not exceed K . Where there are triaxial stresses, the largest of the stresses shall not exceed K .

Table A.1 — Classification of stresses for some typical cases

Vessel component	Location	Origin of stress	Type of stress	Classification
Cylindrical or spherical shell	Shell plate remote from discontinuities	Internal pressure	General membrane Gradient through plate thickness	f_m f_g
		Axial thermal gradient	Membrane Bending	f_g f_g
	Junction with head or flange	Internal pressure	Membrane	f_L
			Bending	f_g
Any shell or end	Any section across entire vessel	External load or moment, or internal pressure	General membrane averaged across full section. Stress component perpendicular to cross section	f_m
		External load or moment	Bending across full section. Stress component perpendicular to cross section	f_m
	Near nozzle or other opening	External load or moment, or internal pressure	Local membrane Bending	f_L f_g
	Any location	Temperature difference between shell and end	Membrane Bending	f_g f_g
Dished end or conical end	Crown	Internal pressure	Membrane Bending	f_m f_b
	Knuckle or junction to shell		Membrane Bending	f_L ^a f_g
Flat end	Centre region	Internal pressure	Membrane Bending	f_m f_b
	Junction to shell		Membrane Bending	f_L f_g
Perforated end or shell	Typical ligament in a uniform pattern	Pressure	Membrane (average through cross section) Bending (average through width of ligament, but gradient through plate)	f_m f_b
	Isolated or atypical ligament		Membrane Bending	f_g f_g
Nozzle	Cross section perpendicular to nozzle axis	Internal pressure or external load or moment	General membrane (average across full section). Stress component perpendicular to section)	f_m
		External load or moment	Bending across nozzle section	f_m
	Nozzle wall	Internal pressure	General membrane Local membrane	f_m f_L
			Bending	f_g
	Differential expansion	Membrane Bending	f_g f_g	
^a Consideration should also be given to the possibility of buckling and excessive deformation in vessels with large diameter -to-thickness ratio.				

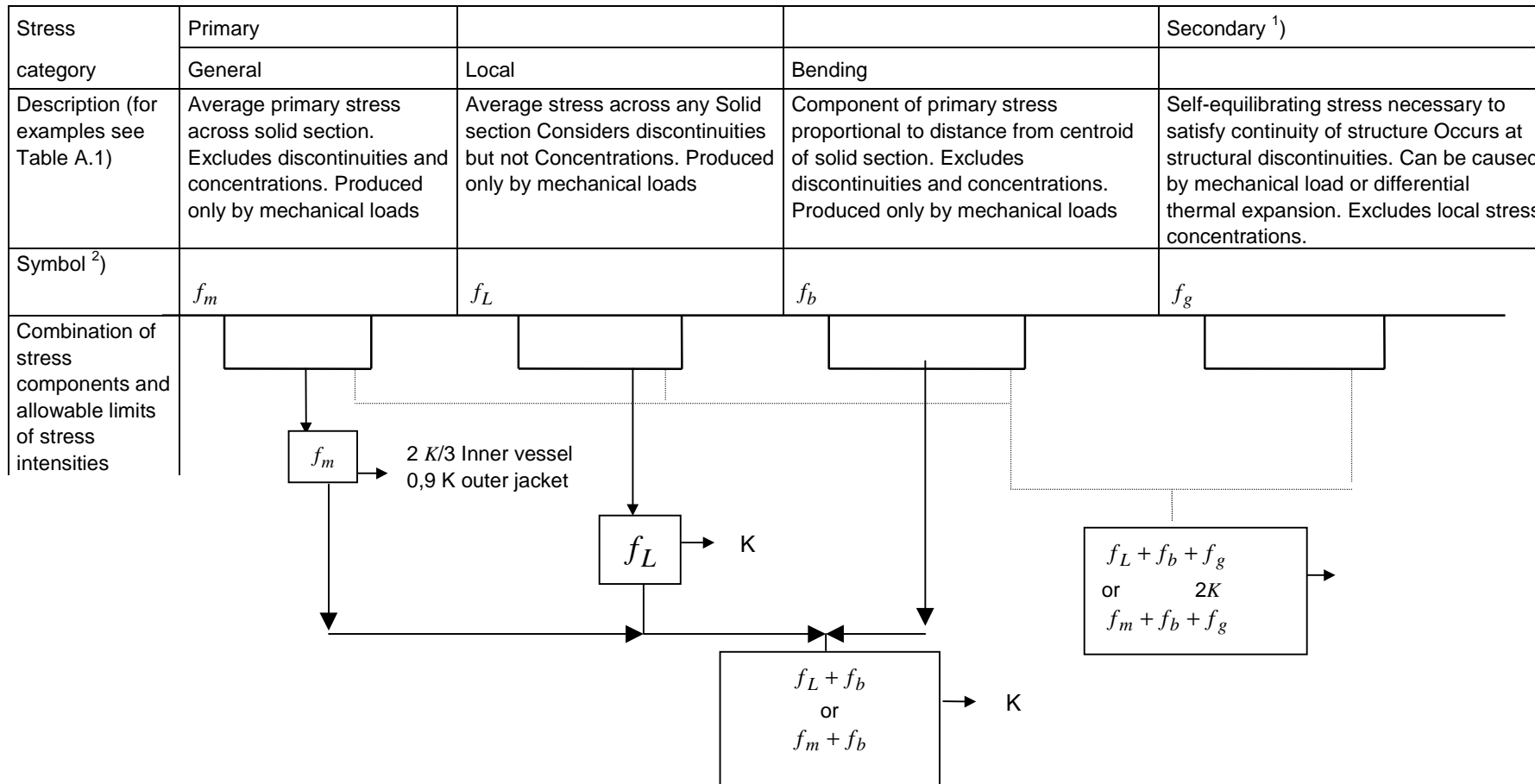

¹⁾ The stresses in category f_g are those parts of the total stress which are produced by thermal gradients, structural discontinuities, etc., and do not include primary stresses which may also exist at the same point. It should be noted, however, that a detailed stress analysis frequently gives the combination of primary and secondary stresses directly and, when appropriate, this calculated value represents the total of f_m (or f_L) + f_b + f_g and not f_g alone.

²⁾ The symbols f_m , f_L , f_b and f_g do not represent single quantities but rather sets of six quantities representing the six stress components.

Figure A.1 — Stress categories and limits of stress intensity

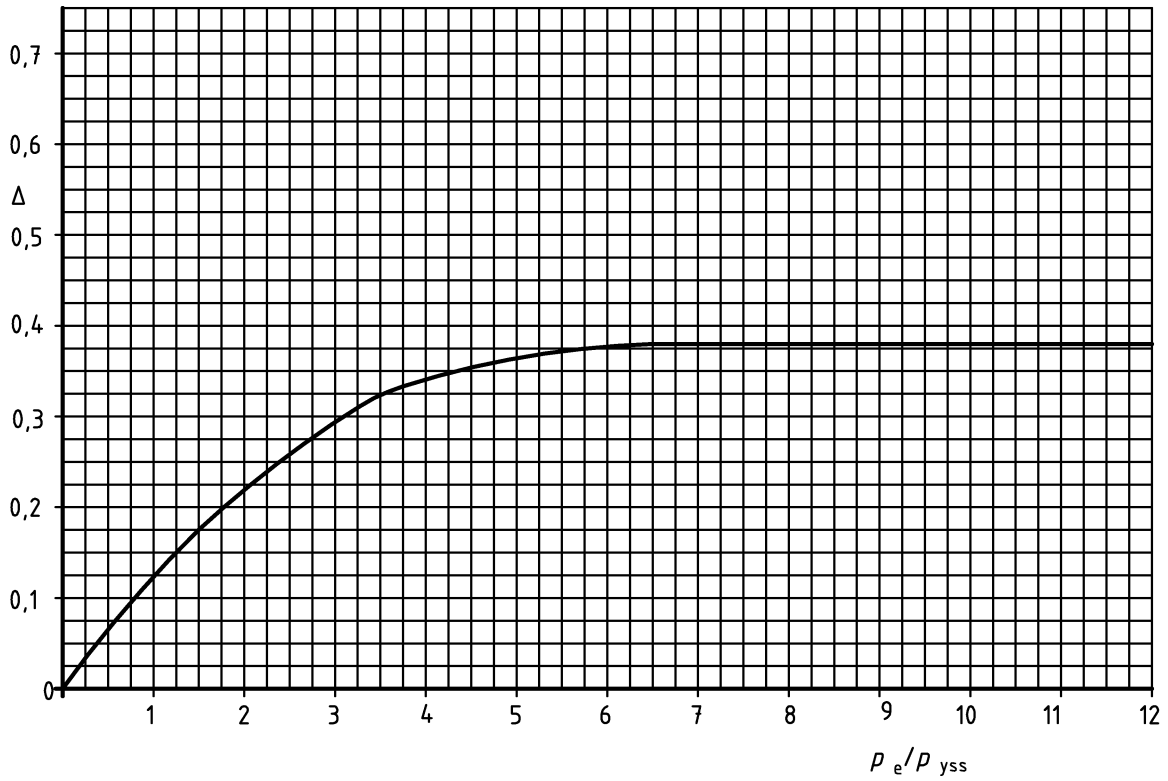

Figure A.2 — For vessels subject to external pressure

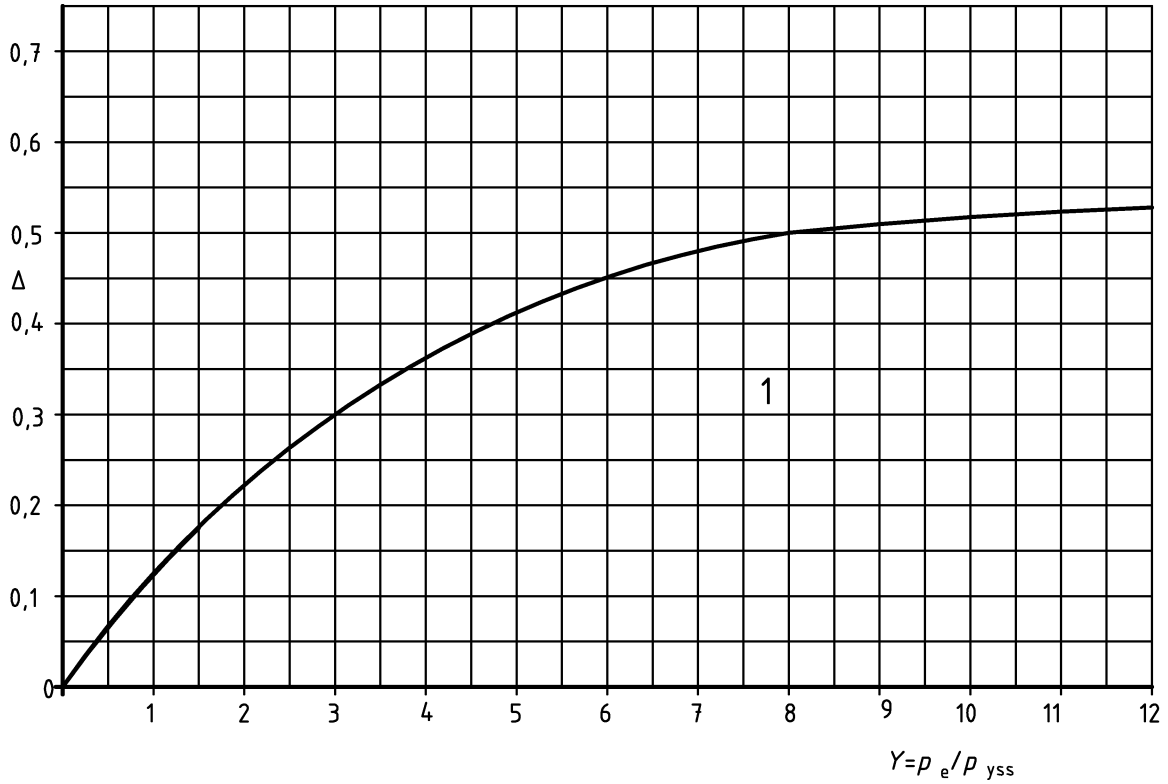

Figure A.3 — For vessels not subject to external pressure

Annex B (normative)

Additional requirements for 9 % Ni steel

B.1 General

Vessels constructed of 9 % Ni steels are normally welded using an austenitic or modified austenitic consumable. The 1 % or 0,2 % proof strength of the parent plate material normally exceeds that of an all weld metal sample. These weld metals exhibit excellent ductility and work hardening characteristics. After work hardening, the enhanced proof strength of the weld metal is maintained within an entirely elastic regime.

The value of K to be adopted in the calculation formula of 4.3.6 is that of the parent 9 % Ni shell material.

During the first proof pressure test after fabrication, the welds plastically strain by a small, but sufficient amount such that their strength increases to create equilibrium with the applied loads. Thereafter the vessel behaves elastically when subjected to the maximum allowable working pressure.

B.2 Specific requirements

B.2.1 The minimum design temperature of vessels constructed of 9 % Ni steel shall not be less than -196 °C.

B.2.2 The maximum design temperature shall be 50 °C and a maximum temperature of 200 °C shall not be exceeded, when defrosting or drying the vessel at low pressure.

B.2.3 The maximum thickness of the vessel at the weld edge preparation shall not exceed 30 mm. A high nickel austenitic weld wire shall be used when the thickness of the vessel at the weld edge preparation exceeds 20 mm.

B.2.4 The full length of all butt joints shall be examined by radiographic or ultrasonic methods before the first proof pressure test. Defects that are unacceptable to this standard shall be repaired and re-examined to demonstrate compliance.

B.2.5 The full length of all branch attachment welds shall be examined by dye penetrant before the first proof pressure test. Imperfections that are unacceptable to this standard shall be repaired and re-examined to demonstrate compliance.

B.2.6 The vessel and all welds shall be examined visually after the proof pressure test to ensure that there is no evidence of gross deformation.

B.2.7 The weld procedure qualification and production control transverse tensile test specimens¹⁾ shall:

- show no gross deformation when subjected to a tensile stress equal to the minimum specified material property K of the parent plate. Some small reduction in area is acceptable due to the expected plastic deformation associated with strain hardening. The measured 1 % proof stress of the transverse tensile test piece when using a 50 mm gauge length shall not be less than the minimum specified material property K of the parent plate;
- demonstrate a rupture strength not less than the minimum specified ultimate strength of the parent plate.

1) These items also apply to work hardened austenitic stainless steel.

EN 13458-2:2002 (E)

B.2.8 Longitudinal bend tests, as permitted by EN 288 shall be used rather than side bend tests when qualifying weld procedures or testing production control test plates. ¹⁾

B.2.9 The heat affected zone at the weld fusion boundary shall be demonstrated to attain an ISO V-notch impact strength of 50 joules at -196 °C, as an average of 3 test pieces, during weld procedure qualification and production control plate testing. The test piece shall be a transverse specimen.

B.2.10 Openings shall not be located with their centre lines closer to principal seams than twice their diameter. ¹⁾

B.2.11 Butt welds shall not be located where they are subject to high bending stresses which can result in plastic cycling and incremental collapse. ¹⁾

B.2.12 9 % Ni vessels may be fitted with nozzles of stainless steel. Where the outside diameter of the nozzle exceeds 75 mm, the stresses in the shell and nozzle due to pressure, mechanical loads and thermal expansion shall be assessed and shown to comply with the requirements of annex A and to provide an adequate fatigue life for the intended application of the vessel.

B.2.13 Filler wires shall be selected from austenitic, modified austenitic or high nickel austenitic materials.

B.2.14 9 % Ni material conforming to EN 10028-4 is suitable for the construction of cryogenic vessels conforming to this standard. Other materials may be suitable.

¹⁾ These items also apply to work hardened austenitic stainless steel.

Annex C (informative)

Pressure strengthening of vessels from austenitic stainless steels

C.1 Introduction

Austenitic stainless steel exhibits stress/strain characteristics (see Figure C.2), different from that of carbon steel (see Figure C.1), that enable stainless steel to accept strain as a means of increasing its proof strength. Plastic deformation of 10 % is possible with steels having an elongation at fracture of at least 35 % in the solution heat treated condition.

Austenitic stainless steel that has been strained to a higher proof strength will retain and even increase its enhanced strength advantage at cryogenic temperatures.

For instance, when austenitic stainless steel is loaded in tension to a stress σ_k above its proof strength and then unloaded a permanent plastic elongation will result. When this steel is loaded again it will remain elastic up to this higher stress which is then the new proof strength; only when the stress exceeds σ_k will the deformation follow the original stress/strain curve.

When the strengthening stress σ_k has been chosen the minimum wall thickness of parts of the vessel can be calculated from the design operating stress to be equal to or less than two thirds of σ_k (which is equal to the new proof strength).

In practice the strengthening is produced by pressurising the finished vessel to a pressure p_k known to produce the required stress which in turn gives the required amount of plastic deformation to withstand the pressure load.

This technology primarily applies to vessels (or part of vessels) of non-complex 'balloon-type' design, i.e. structures where the pressure induced membrane stresses are dominant. Other parts of the vessel are normally designed based on conventional design stress values following clause 4 and the relevant annexes to this standard.

NOTE This method is also known as *Cold-Stretching*. However, using the word *Cold* in connection with cryogenic vessels can be misleading since the strengthening pressure is applied at room temperature. Also, the *Stretching* will be slight if any when using shell material in the work-hardened condition. On the other hand, applying a pressure in excess of the normal test pressure effectively demonstrates the strength and pressure bearing capability of all parts of the complete vessel.

C.2 Field of application

This annex applies to cryogenic pressure vessels made from austenitic stainless steel of a wall thickness of not more than 30 mm, strengthened by pressurisation at room temperature after being completed and intended for a maximum operating temperature of less than 50 °C.

C.3 Definitions and units of measurement

For the purposes of this annex the definitions, symbols and units of measurement given in 3.1 and the following apply.

C.3.1

pressure strengthened vessel

pressure vessel, which has been subjected to a calculated and controlled internal pressure (strengthening pressure) after completion. The wall thickness of such a vessel is calculated on the basis of the stress at the strengthening pressure and not on the basis of the conventional design stress value of the material used

NOTE Pressure vessels made from solution heat treated material will be subject to a controlled plastic deformation during the strengthening operation as its yield point is raised. Pressure vessels made from work-hardened material will be subject to little or no plastic deformation.

C.4 Materials

C.4.1 Accepted materials of construction that have already been proven suitable for pressure strengthening for operating temperatures of not less than $-196\text{ }^{\circ}\text{C}$ are the austenitic stainless steels specified in Table C.1. Requirements regarding these materials are found in EN 10028-7.

When material is delivered in a work-hardened condition, the material should have an elongation at fracture A_5 of not less than 35 %.

Table C.1 — Austenitic stainless steels accepted for pressure strengthening of cryogenic vessels for operating temperatures of not less than $-196\text{ }^{\circ}\text{C}$

Steel designation		Solution heat treated material		Pressure strengthened vessel
Name	Number	$R_{p0.2}$ N/mm ² min	$R_{p1.0}$ N/mm ² min	σ_k N/mm ² max
X5CrNi18-10	1.4301	210	250	410
X2CrNi19-11	1.4306	200	240	400
X2CrNi18-10	1.4311	270	310	470
X6CrNiTi18-10	1.4541	200	240	400
X6CrNiNb18-10	1.4550	200	240	400
X5CrNi19-09	1.4315	270	310	470

C.4.2 In case stable or metastable austenitic steels according to clause 8 of EN 13458-1:2002 other than those listed in Table C.1 are to be qualified for pressure strengthening, or the vessel operating temperature will be below $-196\text{ }^{\circ}\text{C}$, steel quality and welding procedure should be validated by the type approval test detailed below. This test should be carried out in addition to the tests required by 8.1 of EN 13458-1:2002 and 5.6.1 of this standard.

A welded test plate should be subjected to a tensile stress across the weld equal to the anticipated value of σ_k . From this test plate specimens should be tested as follows:

- to test the base material : two tensile tests along the direction of the applied stress and one set of impact tests across the direction of the applied stress;
- to test the weld: two tensile tests across the weld and one set of impact tests of the weld metal according to 3.4 of EN 1252-1:1998.

One tensile test and the impact tests should be carried out at the lowest operating temperature, the other tensile test should be carried out at $20\text{ }^{\circ}\text{C}$.

The base material and the weld should comply with:

$$R_{p0,2} \geq \sigma_k; \quad A_5 \geq 25 \%; \quad a_k \text{ ISO-V} \geq 50 \text{ J/cm}^2$$

C.5 Design

C.5.1 General

C.5.1.1 Wall thicknesses calculated according to C.5.3 and C.5.4 refer to thicknesses before strengthening.

C.5.1.2 Nominal diameters can be used in the design calculations. No allowance is necessary for the possible increase in diameter due to strengthening.

C.5.1.3 Maximum design stress value is limited to 200 N/mm² above $R_{p0,2}$ for the material in the solution heat treated condition.

C.5.1.4 The weld joint factor 1,0 can be used for the calculation of all pressure strengthened parts of the vessel (longitudinal welds in cylinder, cone or end).

C.5.1.5 Pressure strengthening applies to vessels (or part of vessels) where the pressure induced membrane stresses are dominant. Other parts of the vessel should be designed in accordance with clause 4 and the relevant annexes of this standard. This requirement should not preclude utilisation of the strengthening process, provided that the manufacturer can show that it does not cause deformations that impair the integrity of the vessel.

C.5.2 Design for internal pressure

C.5.2.1 Design stress values

The design stress value σ_k at 20 °C can be selected freely up to the highest allowable design stress value $\sigma_{k\max}$ according to Table C.1. This highest allowable design stress value is the same whether the material used is in the solution heat treated or work-hardened condition.

C.5.2.2 Calculation of the strengthening pressure

The required strengthening pressure p_k is calculated according to the formula

$$p_k = 1,5p \tag{C.1}$$

NOTE Strained material is also known to increase its strength when cooled to cryogenic temperatures. However, the effect on strengthening pressure (analogous to the effect on test pressure as in 4.2.3.2 g) of this document) is not taken into account in this annex.

C.5.2.3 Calculation of wall thicknesses

C.5.2.3.1 General

The wall thickness of the various parts of the pressure vessel should be calculated according to applicable sub-clauses of this standard with the modifications shown in Table C.2.

Table C.2 — Modification of formulae for the design of pressure strengthened vessels

Sub-clause of this standard		Modification, see sub-clause in this annex
4.3.6.1	Cylinders and spheres subject to internal pressure	C.5.2.3.3
4.3.6.4	Dished ends subject to internal or external pressure 4.3.6.4.4 Internal pressure calculation (pressure on the concave surface)	C.5.2.3.4
4.3.6.5	Cones subject to internal or external pressure 4.3.6.5.6 internal pressure calculation (pressure on the concave surface) $ \varphi \leq 70^\circ$ 4.3.6.5.7 Internal pressure calculation (pressure on the concave surface) $ \varphi > 70^\circ$	C.5.2.3.4 C.5.2.3.2
4.3.6.6	Flat ends	C.5.2.3.2
4.3.6.7	Openings in cylinders, spheres and cones	C.5.2.3.5

C.5.2.3.2 Parts where bending stresses are dominant and large deformations cannot be accepted, like flat cones according to 4.3.6.5.7 and flat ends according to 4.3.6.6, should be calculated in the normal way using the design pressure p and design stress values according to 4.3.2.3. That is, the effect of the strengthening should not be utilised in such designs.

Additionally, it is recommended that the capability to pass the strengthening without plastic deformation is checked by repeating the calculations using the strengthening pressure (taking the mass of contents into account) for the test pressure p_T and the design stress value at 20 °C from 4.3.2.3 a).

C.5.2.3.3 When designing parts according to 4.3.6.1.3 insert into the applicable formulae the following:

- design stress value σ_k ;
- weld joint factor 1,0.

C.5.2.3.4 Parts according to 4.3.6.4.4 and 4.3.6.5.6 should be designed with the same modifications as in C.5.3.3.2. Additionally the shape factor β for dished ends can be reduced to:

- for 10 % torispherical ends, 2,93;
- for 2:1 torispherical ends, 1,91.

However, it should be demonstrated by calculation or experiment that the strain during strengthening will not cause excessive deformation in regions subject to bending stresses. In cases where the deformation will lead to a better shape (e.g. deeply dished ends turning hemispherical) the method can be used even with large bending stresses.

Also the risk of buckling in regions where compressive stresses occur (i.e. the knuckle of dished ends and corner area of cones) should be paid special attention. But, since buckling is heavily dependent on initial imperfections and work-hardening of the material before pressurisation, there is no substitute for experience. However, the stretching process in itself will reveal any such tendencies (see C.6.1).

C.5.2.3.5 For reinforcements of openings the stiffness of the attachment should be considered so that over-dimensioned reinforcements are avoided. Preferably openings without reinforcement should be used. Unreinforced openings in this context includes openings having reinforcement not complying with 4.3.6.7.5 of this standard.

For openings, where the hole diameter exceeds that given below, it is recommended that the calculation of the reinforcement is made according to 4.3.6.7 of this standard with the same modifications as in C.5.2.3.3.

When using external plate reinforcement or other kinds of reinforcements that are not welded with full penetration, the risk of overloading of the welds during strengthening should be observed.

When ligament efficiency is less than 1, stresses due to strengthening should be analysed according to 4.3.6.7 of this standard.

Largest allowed opening of unreinforced single holes

In the case of holes joining a nozzle etc. to the shell, the inside diameter of the nozzle should not exceed d_{max} .

d_{max} is the diameter of largest allowed opening (major axis for oval holes), mm;

D_y is the outside diameter of shell, mm;

R is the inside crown radius of end, mm;

s_0 is the wall thickness of unpierced shell, mm;

s is the true wall thickness of shell, mm;

$\mu = s_0/s$;

$C = 60\sqrt{2(1-\mu)}$ with a maximum of 60 mm.

$$d_{max} = 0,4\sqrt{D_y s} + C \quad (C.2)$$

The value of d_{max} calculated according to formula (C.2) can be rounded up to the nearest higher even 10 mm. However, it is recommended that d_{max} meet the conditions:

$$d_{max} \leq 150 \text{ mm} \quad (C.3)$$

$$d_{max} \leq 0,2D_y \quad (C.4)$$

The wall thickness of an unpierced cylinder is calculated from

$$s_0 = \frac{pD_y}{20\frac{\sigma_k}{1,5} + 2p} \quad (C.5)$$

The wall thickness of the crown region of an unpierced dished end is calculated from

$$s_0 = \frac{pR}{20\frac{\sigma_k}{1,5}} \quad (C.6)$$

C.5.3 Design for external pressure

C.5.3.1 If a pressure strengthened vessel normally operating under internal pressure can be subject to external pressure, the vessel should also be designed to withstand external pressure according to the applicable sub-clauses of clause 4.

By these calculations the design stress value should be taken from 4.3.2.3. If the pressure strengthened vessel is made from solution heat treated material the safety factors S_k given in 4.3.2.4 can be replaced by $S_k/1,5$.

NOTE This modification is a consequence of the improved shape of the pressure vessel produced by the straining so that a lower factor of safety can be accepted.

In the case of vessels having large nozzles in the shell or when this improvement of the shape is otherwise doubtful, the above modification can be utilised only if measurements after strengthening show that the vessel is not significantly out of round.

C.5.3.2 If a vessel is shaped such that it is subject to an external pressure during the strengthening operation, it should be calculated using the strengthening pressure (taking the mass of contents into account) as a test pressure p_T and the material properties at 20 °C from 4.3.2.3.2 of this standard.

C.6 Manufacturing and inspection

C.6.1 Strengthening procedure

C.6.1.1 The strengthening operation, which is a step in the production of the finished vessel, should be made following written instructions. These instructions should include the steps described in C.6.1.2 to C.6.1.6.

When vessels under pressure require inspection and measurement adequate facilities and procedures should be employed to assure the safety of inspectors, employees and the public.

C.6.1.2 Fill the vessel with liquid. Before the vessel is closed, wait for at least 15 min to let any air dissolved in the liquid escape. Then top up and seal the vessel.

C.6.1.3 The circumference of all courses should be measured (e.g. with steel tapes) where the largest increase in cross-section is expected. The strain rate during the strengthening operation should be calculated over the full circumference.

C.6.1.4 The strengthening is normally carried out as follows: the pressure is raised to the strengthening pressure and maintained until the strain rate has dropped to less than 0,1 %/h. The time under pressure should be not less than 1 h (see however C.6.1.5). The strain rate should be checked by repeated measurements of the circumference according to C.6.1.2. The requirement of 0,1 %/h should be met during the last half hour.

NOTE The total time under pressure can be long. This can be reduced if a 5 % higher pressure is applied during the first 0,5 h to 1 h of the operation.

C.6.1.5 For pressure vessels having a diameter not more than 2 000 mm the time under pressure can be reduced to 30 min and the requirement of 0,1 %/h be met during the last 15 min.

C.6.1.6 The strengthening operation replaces the initial pressure testing of the vessel. Should later pressure testing be required, only the normal test pressure should be used. If the vessel requires to be repaired, this repair and pressure testing or possibly renewed strengthening should be carried out in accordance with C.6.3.4.

C.6.2 Procedure record

There should be a written record of the operation, containing at least the following information:

- pressurising sequence specifying pressure readings and time;
- circumference measurements before, during and after pressurisation;
- strain rate calculations from circumference measurements;
- any significant changes of shape and size relevant to the functioning of the vessel;
- any requirement for renewed strengthening (according to C.6.1.5 and C.6.3.4).

C.6.3 Welding

C.6.3.1 The strengthening method presumes high quality welding. The same rules apply as for conventionally produced cryogenic vessels, except that production control test plates need not be taken.

C.6.3.2 Non-destructive testing should be carried out before the strengthening to the extent stipulated in 6.3 for the weld joint factor 1,0. Where high local stress and strain concentrations can be expected during the strengthening operation, examination with liquid penetrant should also be carried out e.g. at changes in wall-thickness or at welded nozzles.

C.6.3.3 After the strengthening operation and reducing the pressure to the design pressure welds should be visually examined externally for their full lengths. Places which have been examined with liquid penetrant according to C.6.3.2 should also if possible be tested at random using a volumetric method (preferably by radiographic examination).

C.6.3.4 Renewed strengthening should be carried out if pressure strengthened parts of the vessel have been significantly affected by post strengthening welding. Exceptions are permitted for tack-welding of attachments carrying low loads only (e.g. insulation supports) and welding of nozzles not more than 10 % of the vessel inner diameter (with a maximum of 100 mm) or minor weld repairs with comparable effect on the construction. Such welds should be examined according to C.6.3.2 and C.6.3.3.

Unless renewed pressure strengthening is carried out there should be a normal pressure test as required by 6.5.2 after all welding on pressure retaining parts.

C.6.4 Pressure vessel drawing

C.6.4.1 In addition to the information required by 4.2.2, the drawing should bear the following text:

- the vessel is manufactured according to this annex;
- strengthening pressure in bars;
- thicknesses and diameters shown apply before strengthening.

C.6.4.2 Details to be welded in place after the strengthening should be marked on the drawing.

C.6.5 Data plate

The data plate should in addition to the information according to clause 10 of EN 13458-1:2002 bear the text "PRESSURE STRENGTHENED".

C.7 Comments

C.7.1 Strengthening theory

Austenitic stainless steels exhibit considerable work-hardening upon deformation while retaining the characteristics of the material. The stress required for further deformation increases continuously as the deformation increases. Thus, a stress/strain curve for austenitic steel does not have the flow region typical of carbon and low-alloy steels. Compare the stress/strain curves in Figures C. 1 and C. 2.

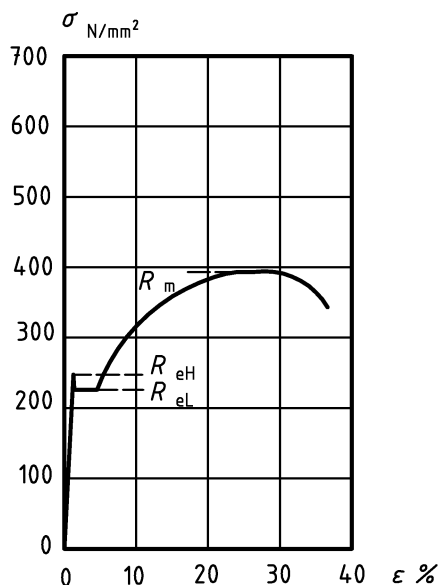

Figure C.1 — Stress/strain curve for carbon steel

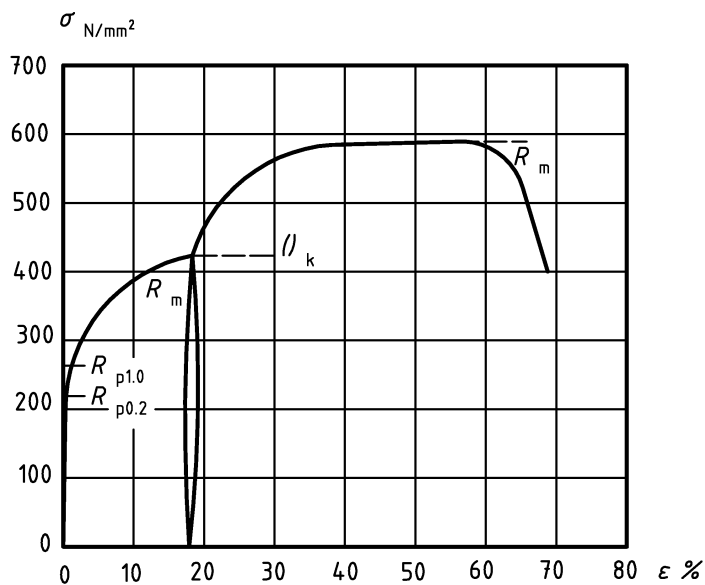

Figure C.2 — Stress/strain curve for austenitic stainless steel

If a tensile test piece of solution heat treated austenitic stainless steel is loaded to a strengthening stress σ_k and then unloaded, a permanent plastic elongation will be found. When the same test piece is loaded again the deformation will remain elastic up to a higher stress level than before. Only when the stress σ_k is exceeded the plastic deformation will continue along the original curve.

A test piece which has been loaded to the strengthening stress σ_k can be regarded as a new test piece with:

$$R_{p0,2} = \sigma_k \tag{C.7}$$

An austenitic stainless steel that has been stretched at room temperature to a higher proof strength also exhibits higher proof strength stress at all other temperatures.

The toughness of the material after stretching to 10 % (nominal strain) will still be satisfactory, since austenitic steels in the solution heat treated condition has an elongation at fracture not less than 35 %.

The plastic deformation required is achieved by subjecting the finished pressure vessel to a strengthening pressure p_k . This pressure is calculated so that there is sufficient safety margin with respect to plastic deformation from stresses caused by a pressure equal to the design pressure p .

Minimum wall thicknesses for the different parts of the vessel are calculated after establishing a suitable design stress value σ_k .

During the strengthening of the finished vessel, the material reaches a strengthening stress (σ_k) that is at least 1,5 times the design operating stress.

C.7.2 Work-hardened material

C.7.2.1 The term work-hardened material should be applied to material that has had its proof strength raised through cold rolling, roll straightening, uniaxial stretching in a stretching machine or other types of cold work.

C.7.2.2 Work-hardened material can be used in order to reduce or eliminate the deformation due to strengthening of the pressure vessel. It is primarily used in cylinders for internal pressure.

C.7.2.3 The increase in the proof strength of a work-hardened material is about the same in all directions. The proof strength of work-hardened plate should be determined on samples taken across the direction of rolling or stretching respectively.

C.7.2.4 The structure of work-hardened material differs from solution heat treated material only in that the number of dislocations is higher. Material that has been subject to a homogeneous deformation is free from residual stresses. Work-hardening does not significantly affect the resistance to general corrosion.

Welding of work-hardened material gives rise to a heat-affected zone (HAZ), the width of which depends on the welding method. In arc welding with coated electrodes, the width of the zone is about equal to the thickness of the material.

The proof strength in the zone can be reduced, but the subsequent strengthening restores it to about the same level as that of the surrounding material.

Impact toughness and corrosion resistance in the zone depend primarily on the initial material condition (analysis, well annealed structure) and the welding method (extent of heating) but only slightly on the degree of strengthening.

Strengthening of a pressure vessel generally decreases local residual stresses introduced into the vessel during the manufacturing process.

C.7.3 Derivation of formulae

C.7.3.1 Consider a cylinder of middle diameter D and design pressure p , which has been strengthened to a design stress value σ_k . Its wall thickness should comply with the formula for cylinders in 4.3.6.1.3 of this standard:

$$s = \frac{pDs_F}{20\sigma_k z} \quad (\text{C.8})$$

It is recommended that the strengthening is carried out in such a way that the shell is subjected to the stress σ_k . The stress in a cylinder is:

$$\sigma = \frac{pD}{20s} \quad (\text{C.9})$$

and the strengthening pressure p_k will therefore be :

$$p_k = \frac{20s\sigma_k}{D} \quad (\text{C.10})$$

If s according to formula (C.2) is substituted:

$$p_k = p \frac{S_F}{z} \quad (\text{C.11})$$

Since $S_F = 1,5$ and $z = 1,0$ this corresponds to formula (C.1). Obviously cylinders can be calculated from the formula in 4.3.6.1.3 of this standard if σ_k is inserted as the design stress value and 1,0 as the weld joint factor.

NOTE If a weld joint factor z less than 1,0 is applied to any single main seam an increase in strengthening pressure is required according to formula (C.5). To sustain this higher pressure the thickness of all parts of the vessel would then need to be increased.

C.7.3.2 If a shell consists of several courses and one of them is made thicker than the others, it will have a lower σ_k than the other courses after strengthening.

The thicker course then needs a higher strengthening pressure than the others. Since this is impossible, this course will fail to satisfy formula (C.8) (not "strengthened enough"), as the anticipated proof strength σ_k will not be reached.

In order to achieve the full theoretical effect throughout the vessel, it would be necessary to decrease the thickness of the thicker course. Since this would hardly increase the safety of the vessel it is allowed to use greater thickness in some parts, e.g. where required by external loads, even if this is not theoretically correct.

Correspondingly, constant wall thickness is allowed in conical ends, even though the strengthening theory strictly speaking requires the thickness to be decreased in proportion to the radius. Similarly, the spherical part of a dished end will in some cases be "insufficiently pressure strengthened".

C.7.3.3 The derivation of formulae in C.7.3.1 applies to parts free from bending stresses, i.e. cylinders, spheres and hemispherical ends.

Utilisation of the strengthening effect is generally not permitted for parts subject to primary bending stresses. For such parts, it is necessary to investigate the stresses during strengthening (see C.5.2.3.2) and normal operation.

Certain pressure vessel parts, such as dished and conical ends, contain so-called secondary bending stresses (see annex A). It is permissible to use the strengthening effect in such parts, but it is recommended that the magnitude of the secondary bending stresses is investigated and should normally not exceed $2\sigma_k$.

Excepted from this, requirement of investigation are 2:1 torispherical ends, where experience has shown the bending stresses to be moderate.

C.7.3.4 Experience has shown that it is possible to use design stress values for pressure strengthened material when dimensioning reinforcement pads according to 4.3.6.7.

C.7.3.5 This annex does not preclude utilisation of the strengthening effect, provided that the manufacturer can show that it does not cause harmful deformation or other problems.

C.7.4 Deformations at strengthening

C.7.4.1 The highest allowable design stress value $\sigma_{k\max}$ for the different steels has consistently been set 200 N/mm² higher than $R_{p0.2}$ for the solution heat treated material.

In conventional tensile testing, this maximum stress produces less than 10 % elongation.

C.7.4.2 The strengthening process can be simulated in tensile testing by allowing extra time under load. This increases the elongation under maximum stress by another 1 % to 2 %.

After simulated strengthening, the proof strength $R_{p0.2}$, of the material (calculated on basis of the cross sectional area before the strengthening) is about 30 N/mm² higher than the strengthening stress σ_k used.

C.7.4.3 A multi-axial stress state result in other elongation values than tensile testing. These elongation values can be assessed according to a graph of the deformation hardening of the material as applied to the effective values of stress σ and elongation ε .

$$\sigma = \sqrt{\frac{1}{2}[(\sigma_1 - \sigma_2)^2 + (\sigma_2 - \sigma_3)^2 + (\sigma_3 - \sigma_1)^2]}$$

$$\varepsilon = \sqrt{\frac{2}{9}[(\varepsilon_1 - \varepsilon_2)^2 + (\varepsilon_2 - \varepsilon_3)^2 + (\varepsilon_3 - \varepsilon_1)^2]}$$

If the effective values are set = 1, the principal stresses and elongations obtained for the simplest stress conditions are given in Table C.3:

Table C.3 — Stresses and elongations for different load cases

	True stress				True elongation			
	σ_1	σ_2	σ_3	$\underline{\sigma}$	ε_1	ε_2	ε_3	$\underline{\varepsilon}$
Tensile test	1	0	0	1	1	-0,5	-0,5	1
Cylinder	1,15	0,58	0	1	0,87	0	-0,87	1
Sphere	1	1	0	1	0,5	0,5	-1	1

Among other things, Table C.3 expresses the fact that a tensile test sample contracts in two dimensions, while a cylinder decreases only in thickness by an amount corresponding to the increased circumference.

Table C.3 shows that a certain effective stress $\underline{\sigma}$ produces different elongation in the principal stress direction ε_1 for the different load cases. The same effective stress that produces a strain of 10 % in a tensile test ($\varepsilon_1 = 1,0$) produces a circumferential strain 8,7 % ($\varepsilon_1 = 0,87$) in a cylinder shell and 5 % ($\varepsilon_1 = 0,5$) in a sphere.

The true stresses σ_1 , σ_2 , σ_3 and σ are calculated on basis of the cross-sectional area of the material after deformation. If instead the nominal stresses are used, calculated on basis of the original cross-sectional area of the material, the comparison of strains will be different.

The following example gives an indication of the difference.

EXAMPLE Values from a typical deformation hardening curve of austenitic stainless steel are used, i.e. 0,2 %/280 N/mm² and 10 %/420 N/mm². If equal nominal principal stresses $\sigma_{1 \text{ nom}}$ are applied to this material, the principal strain ε_1 for the cylinder is altered from 0,87 to 0,66 and for the sphere from 0,5 to 0,58.

The strain at bursting pressure is half of the maximum homogeneous strain at tensile testing for a cylinder and one third for a sphere.

C.7.4.4 In practice, the maximum circumferential strain of cylinders is usually 3 % to 5 % when using solution heat treated plate less in the spherical part of the ends. The following factors contribute to the measured values being lower than the theoretically calculated maximum value:

- the proof strength $R_{p0,2}$ is higher than the specified minimum for the material;
- the plate thickness is greater than nominal;
- there are reinforcing effects of ends, nozzles, etc.

C.7.4.5 It should be observed that strengthening of pressure vessels of solution heat treated material can affect the position, direction and roundness of nozzles. This does not entail any reduction of the safety of the vessel, but can in certain cases be a nuisance to the user.

NOTE One way to minimise these changes is to weld the nozzles in place after the strengthening, whereupon the vessel can require renewed strengthening (see C.6.3.4). This second strengthening generally leads to much smaller deformations.

C.7.4.6 When a welded tube is used for nozzles in a cylinder (or cone), the longitudinal weld of the tube should be located in the direction where the stresses are lowest, i.e. in a plane perpendicular to the longitudinal axis of the cylinder (or cone).

Annex D (normative)

Pressure limiting systems

In designing the pressure limiting systems, the manufacturer is required to assess the hazards that apply to the pressure equipment being manufactured. The equipment shall then be designed and constructed taking account of the assessment.

In selecting the most appropriate solutions, the manufacturer shall:

- eliminate or reduce hazards as far as is reasonably possible; and
- take the necessary protection measures against hazards which cannot be reasonably eliminated.

The selection of numbers, type and arrangement of the devices in the pressure limiting system is complex and requires the designer to consider carefully quality, reliability, service, application and maintenance.

In this standard no specific system of excess pressure protection is recommended, but two examples of relief systems currently in use are shown in Figure D.1:

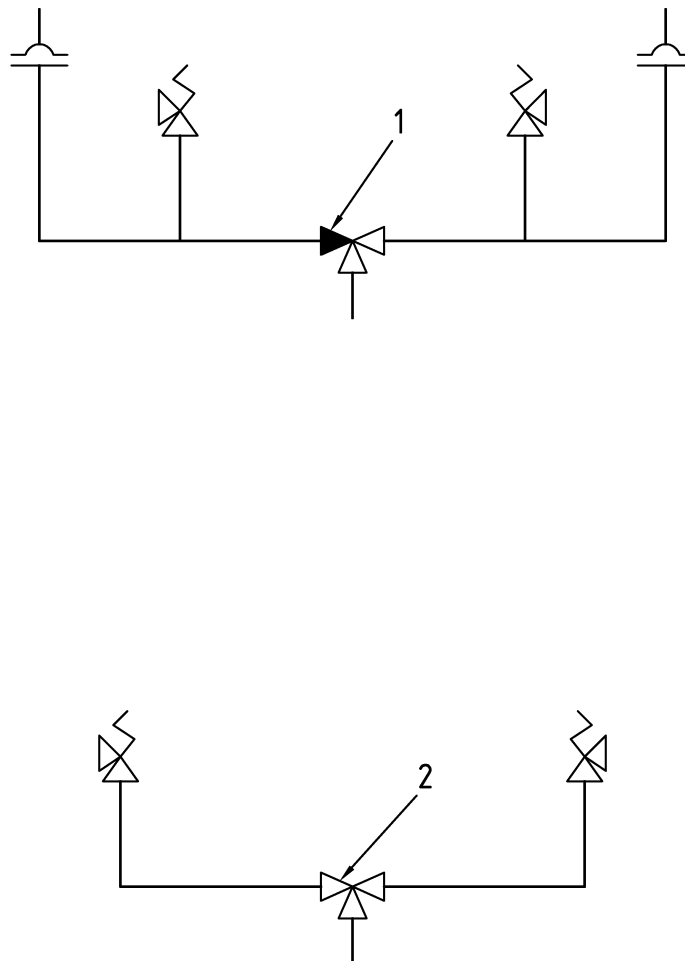

- Key**
- 1 Changeover valve
 - 2 3-way valve

Figure D.1 — Examples of relief systems

Annex E (normative)

Further use of the material cold properties to resist pressure loads

E.1 General

There are significant benefits to be gained from taking advantage of the enhanced properties of some materials such as stainless steels, 9 % Ni steels and aluminium alloys at cryogenic temperature and there are examples of these phenomena currently used in pressurized systems. This annex deals with a theoretical design method for further use of the material cold properties to resist pressure loads.

E.2 Introduction

This annex concerns a method of calculation of the wall thickness of inner vessel of vacuum insulated cryogenic vessels permanently containing liquids. Cold vessels designed for air gases (nitrogen, oxygen, argon) which are refilled systematically when the level of cryogenic liquid drops below 25 %, can be taken as an example.

This calculation is based on the following considerations.

As long as there is cryogenic liquid - even in very low quantities - in a static vacuum insulated cryogenic vessel storage, the temperature of the "hottest" point of the wall of the inner vessel does not exceed a temperature t which we can consider as being the maximum allowable temperature for normal operating conditions.

This temperature t can be determined experimentally for each type of cryogenic vessel, taking into account all likely operating conditions. An example of calculation with $t = -80$ °C is given at the end of this annex.

The calculation of the wall thickness of the inner vessel can be performed on the basis of the material property at the temperature t . In such a case, an additional protection system activated by either low liquid level or the direct temperature t is fitted.

The additional protection system shall operate, in order to prevent excessive stresses in a vessel, at ambient temperature.

For the initial pressure test $p_T = p_s + 1$ bar can be considered for the "exceptional design condition".

E.3 Field of application

This annex is applicable to cryogenic pressure vessels manufactured from materials satisfying the toughness requirements of EN 1252-1.

E.4 General requirements

When the method described in this annex, is followed, all the requirements included in the main part of this standard shall be followed with some exceptions concerning the calculation method (4.2 and 4.3) as indicated in E.5.

E.5 Specific calculation methods

In this specific calculation method the modifications to the requirements of the main part of this European Standard are:

a) 4.2.3.2 b) replaced by:

- pressure during operation when the vessel contains only gaseous product at t in °C.

$$p_{cG} = p_s + 1 \text{ bar}$$

b) 4.2.3.2 d) replaced by :

- reactions at the support points of the inner vessel during operation when the vessel contains only gaseous product at t °C. The reactions shall be determined by the weight of the inner vessel, its contents and seismic loadings where appropriate. The seismic loadings shall consider any forces exerted on the vessel by the insulation.

c) 4.2.3.2 g) replaced by:

- pressure test: The value used for validation purposes shall be the highest of:

$$p_T = 1,25 (p_s + p_L + 1) \frac{K_{20}}{K_{design}} \text{ (normal design condition, full vessel);}$$

$$p_T = 1,43 (p_s + 1) \frac{K_{20}}{K_t} \text{ (normal design condition, nearly empty vessel);}$$

$$p_T = p_s + 1 \text{ (exceptional design condition) ;}$$

- considered for each element of the vessel e.g. shell, courses, head, etc.;
- the 1 bar is added to allow for the external vacuum.

d) 4.2.3.2 j) 2 replaced by:

- operation at maximum allowable working pressure when the vessel is filled with gas at t in °C : b) + d);

e) 4.2.6.2 to add at the end:

- in addition, the inner vessel shall be fitted with an additional protection system operating under pressure p'_s so that:

$$p'_s = (p_s + 1) \frac{K_{20}}{K_t} - 1$$

- when the level of liquid drops below a minimum level, in no case lower than 5 % or when the temperature exceeds the predetermined design temperature t . This system shall be agreed by the purchaser, the manufacturer and the notified body and shall be at least as reliable as that of the pressure limiting system.

f) 4.3.2.2 b) replaced by:

- in accordance with 4.2.3.2 j), 3), 4) and 5);
- material properties determined in accordance with 4.3.2.3.2 shall be adopted.

g) 4.3.2.2 to add a new c):

- in accordance with the modified 4.2.3.2 j) 2) (see before);
- material properties determined in accordance with the new following 4.3.2.3.4 shall be adopted.

h) add a new 4.3.2.3.4

- at maximum allowable temperature t for normal operating conditions:
- this temperature t is the maximum temperature of the wall of the inner vessel taking into account all foreseeable operating condition. These conditions shall be determined and agreed with a notified body. The temperature used by the designer shall not be lower than the proven maximum temperature;
- the K_t value of K at t temperature shall be determined from the material standard (see EN 10028-7:2000, annex C for austenitic stainless steel) or shall be guaranteed by the material manufacturer.

EN 13458-2:2002 (E)

EXAMPLE Calculations of the thickness of the cylindrical part of the inner vessel of a cold converter 11 000/20 bar

p_s is the maximum operating pressure = 20 bar
 p_L is the hydrostatic pressure = 0,82 bar
 D_i is the inside diameter = 1 480 mm
 t is the maximum allowable temperature for normal operation conditions

Material: X2CrNiN 18-10 (304LN)
 $K_{+20} = 310$ MPa
 $K_t = K_{-80} = 420$ MPa
 $K_{design} = K_{-140} = 531$ MPa

Type of calculation	Calculation according to the main part of this standard ($t = + 20$ °C)		Calculation according to annex E ($t = - 80$ °C)	
		$v = 1$	$v = 0,85$	
1) According to 4.2.3.2 j) 1) (c, e and f neglected in first approximation)	$e_1 = \frac{(p_s + p_L + 1)D_i}{20 \frac{K_{-140}}{1,5} v}$	4,56 mm	5,37 mm	$e_1 = 4.2.3.2$ 4,56 mm
2) According to 4.2.3.2 j) 2) and E.4 d)(d neglected in first approximation)	$e_2 = \frac{(p_s + 1)D_i}{20 \frac{K_{20}}{1,5} v}$	7,52 mm	8,85 mm	$e_2 = \frac{(p_s + 1)D_i}{20 \frac{K_{-80}}{1,5} v}$ 5,55 mm
3) According to 4.2.3.2 g) and E.4 c)	$p_T = \text{Max} \left\{ \begin{array}{l} 1,43(p_s + 1) \\ 1,25(p_s + p_L + 1) \frac{K_{20}}{K_{-140}} \end{array} \right.$	30,03 bar 15,92 bar		$p_T = \text{Max} \left\{ \begin{array}{l} 1,43(p_s + 1) \frac{K_{20}}{K_{-80}} \\ 1,25(p_s + p_L + 1) \frac{K_{20}}{K_{-140}} \\ p_s + 1 \end{array} \right.$ 22,16 bar 15,92 bar 21 bar
4) According to 4.2.3.2 j) 3)	$e_3 = \frac{p_T D_i}{20 \frac{K_{20}}{1,05}}$	7,52 mm		$e_3 = \frac{p_T D_i}{20 \frac{K_{20}}{1,05}}$ 5,55 mm
Thickness to be used gain on thickness		7,52 mm	8,85 mm	5,55 mm 26 %

Annex F (informative)

Specific weld details

F.1 Field of application

Specific weld details given in F.2 are currently in common usage in cryogenic vessels and are appropriate to this service. Although the scope of EN 1708-1:1998 does not specifically consider the application of weld details to cryogenic vessels, the manufacturer can consult it for guidance.

F.2 Specific weld detail

In general the welds are to be adequate to carry the expected loads and need not be designed on the basis of joint wall thickness.

F.2.1 Joggle joint, see Figure F.1

This joint can be used for cylinder to cylinder and end to cylinder (excluding cone to cylinder) connections provided that:

- a) when the flanged section of a dished end is joggled, the joggle is sufficiently clear of the knuckle radius to ensure that the edge of the circumferential seam is at least 12 mm clear of the knuckle (see 4.3.6.4.2 for the dimensions);
- b) when a cylinder with a longitudinal seam is joggled:
 - the welds are ground flush internally and externally for a distance of approximately 50 mm prior to joggling with no reduction of plate thickness below the required minimum; and
 - on completion of joggling, the area of the weld is subjected to dye penetrant examination and is proven to be free of cracks;
- c) the offset section which forms the weld backing is a close fit within its mating section at the weld round the entire circumference;
- d) the profile of the offset is a smooth radius without sharp corners;
- e) on completion of welding the weld fills the groove smoothly to the full thickness of the plate edges being joined;
- f) the junction of the longitudinal and circumferential seams are examined radiographically and found to be free from significant defects.

F.2.2 Intermediate ends, see Figure F.2 and 4.3.6.4.3.

F.2.3 Backing strip, see Figure F.3.

Can be used only for circumferential seams in cylinders, ends, nozzles and interspace pipes and for seams in ends, when the second side is inaccessible for welding and provided that non-destructive testing can be satisfactorily carried out where applicable.

F.2.4 End plate closure, see Figure F.4 for two examples of the many ways of welding flat plates. See also Figure 12.

F.2.5 Non full penetration nozzle weld, see Figure F.5

Can be used to attach set in nozzles to ends and cylinders provided that the strength of the attachment welds can be demonstrated to be sufficient to contain the design nozzle loadings.

F.2.6 Non continuous fillet weld on attachments.

Can be used for all attachments to main pressure components provided that the following criteria are met:

- strength is adequate for design loadings;
- crevices between attached component and main pressure envelope can be demonstrated not to conflict with F.3.

F.3 Oxygen service requirements

The need for cleanliness of equipment in liquid oxygen and other oxidising liquid service is described in EN 1797 and EN 12300.

The internal weld details should be such that debris, contaminants, hydrocarbons or degreasants can not accumulate to such a quantity so as to cause a fire risk in future operation.

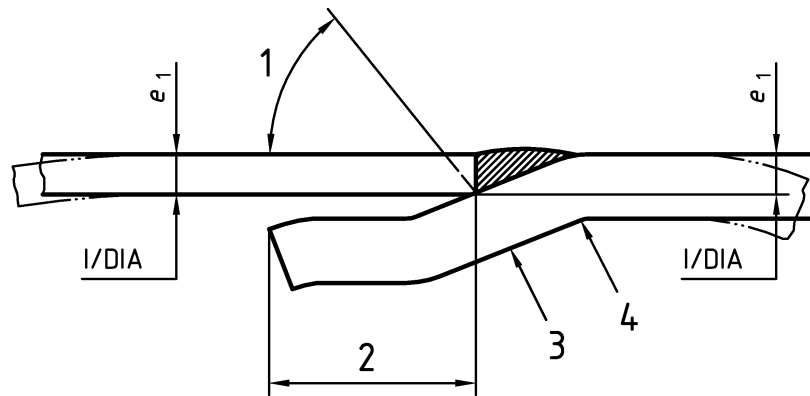

Key

- 1 Bevel optional
- 2 As desired
- 3 Depth of offset = e_1
- 4 Avoid sharp break

Figure F.1 — Joggle joint

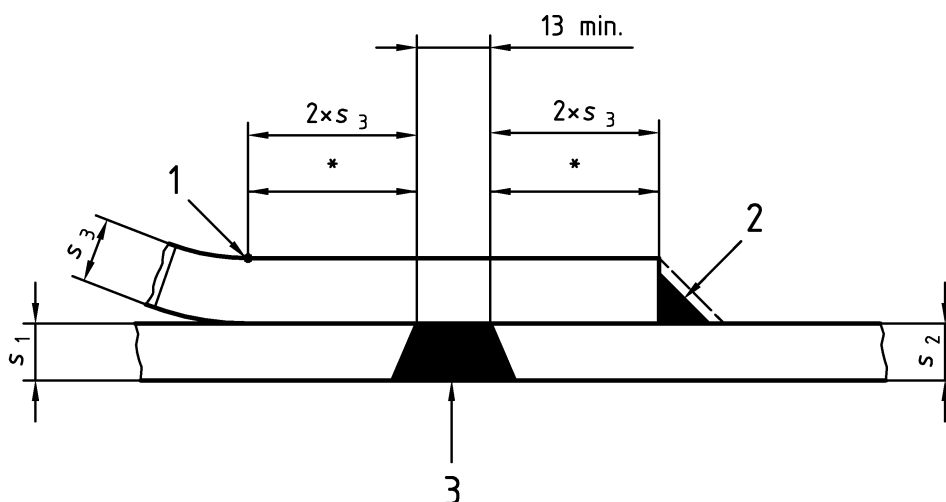

Key

- 1 Tangent point
- 2 Continuous fillet weld
- 3 Butt weld
- s_1 Cylinder thickness
- s_2 Cylinder thickness
- s_3 End thickness
- * Need not exceed 25 mm

NOTE Cylinder thickness s_1 and s_2 can vary.

Figure F.2 — Intermediate end

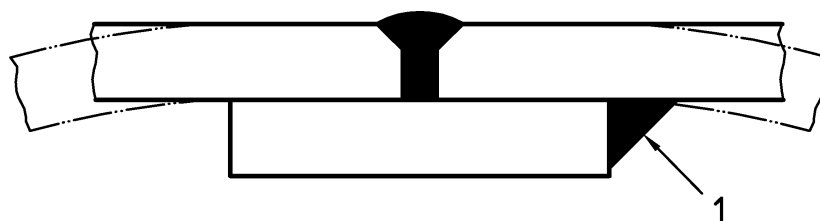

Key

- 1 Intermittent or continuous fillet weld

Figure F.3 — Backing strip

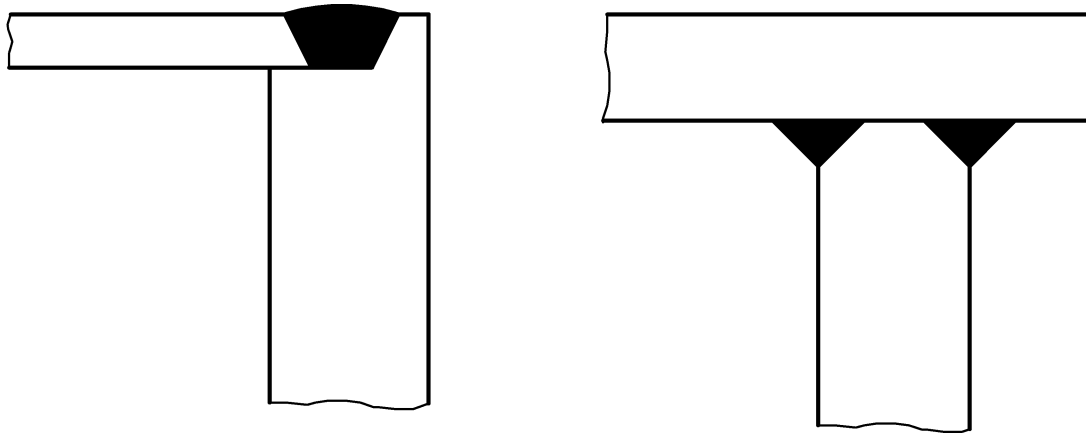

Figure F.4 — End plate closure (examples)

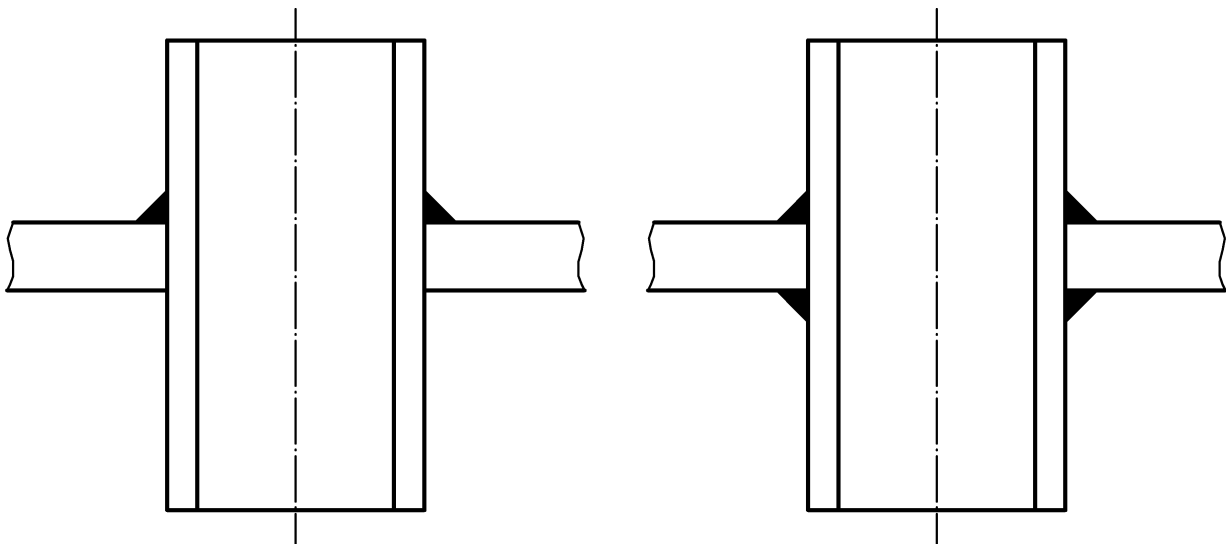

Figure F.5 — Non full penetration nozzle welds

Annex G (normative)

Additional requirements for flammable fluids

G.1 In addition to the requirement of clauses 4, 5 and 6, static vacuum insulated vessels designed for use with the gases listed in 3.1 of EN 13458-1:2002 shall comply to the additional items given in G.2 to G.10.

G.2 Means shall be provided to ensure that the vessel is not filled to more than 95 % of its total volume, with liquid at the filling condition.

G.3 The selection and use of materials and joining procedures shall be carefully considered in the design of the installation to avoid secondary failure in the event of external fire.

G.4 For vessels of not more than 5 t capacity, the first valve of the supply line shall be close to the vessel and capable of being safety operated in an emergency.

G.5 For vessels of more than 50 t capacity a remotely controlled shut off valve, with a mechanical, pneumatic or electrical position indicator shall be fitted before or after the first manual locking shut off valve connected to the liquid phase of the filling and supply pipes. The remotely controlled valve shall operate in a fail safe mode. The fittings shall be designed so that they continue to function to the necessary extent at the temperatures to be expected in the event of a self produced fire.

G.6 For vessels of more than 5 t and not more than 50 t capacity a remotely controlled shut-off valve shall be fitted before or after the first manual shut-off valve connected to the liquid phase of the supply pipes.

G.7 For vessels of more than 50 t capacity the first shut off fitting in the filling and supply pipe for the liquid phase shall be designed as a welded outer fitting of fire-safe quality or as an inner fitting.

G.8 The secondary means of isolation may be within the user installation and shall provide an equivalent level of protection.

G.9 Vessels shall be equipped with safety devices against overfilling (level limiter). Vessels with a capacity of more than 50 t shall be equipped with two independent safety devices protecting against overfilling, whereby one such safety device may be incorporated in the level indicator. The two devices protecting against overfilling should operate with different measuring methods.

G.10 Because of the risk of fire and explosion, consideration shall be given in the design of the installation to the provision of:

- a) upward venting stacks, means of preventing water blockage or freezing and duplicate stacks;
- b) leak-tight piping and equipment.

Annex H (informative)

Non-design requirements for flammable fluids

H.1 All relief devices, blowdown and purge valves should be connected to a venting system that discharges the contents safely.

H.2 All materials used should be compatible with the specific flammable fluid under consideration.

H.3 All valves and equipment should be suitable for use with the specific cryogenic flammable fluid under consideration.

H.4 The design of the static vessel and its installation should ensure, by the provision of suitable vents, that flammable gas cannot accumulate in cabinets, etc.

H.5 All metallic components of the static vessels should be electrically continuous. The whole installation should be provided with earthing devices so that the resistance to earth is less than 10 Ω .

H.6 In the particular case of liquid hydrogen the possibility of air condensing on uninsulated coldparts should be considered.

H.7 The liquid fill line secondary isolation valve should be either a non-return valve or fail-closed automatic shut-off valve.

H.8 Arrangements allowing the vessel (initially) and the loading/filling pipework system to be purged with a non-flammable/non-oxidising gas.

Annex I (normative)

Outer jacket relief devices

I.1 Field of application

This annex covers the requirements for design, manufacture and testing of pressure protection devices required on outer jackets of vacuum insulated cryogenic vessels in order to reduce any accidental accumulation of pressure.

I.2 Requirements

I.2.1 General

The device shall be either a relief plate/plug or a bursting disc.

Bursting disc devices shall be in accordance with prEN ISO 4126-2.

I.2.2 Design

The pressure protection device shall be capable of withstanding full vacuum and all demands of normal vessel operation including its own mass acceleration during transportation.

The set pressure and the open relieving area are specified in 4.2.6.3. Consideration shall be given to prevention of blocking of the device by insulation materials during operation.

The plate or plug of a relief plate/plug type device shall be designed and installed such that it cannot harm personnel when ejected.

I.2.3 Materials

The pressure protection devices shall be resistant to normal atmospheric corrosion. The materials of construction shall be suitable for the range of ambient temperatures expected in service.

I.2.4 Testing

Relief plate/plug type relieving devices shall not require testing other than a prototype test to verify the set pressure.

Burst disc assemblies shall be tested in accordance with prEN ISO 4126-2.

I.2.5 Inspection

Relief plate/plug type devices shall be subjected to an inspection programme that ensures compliance with the drawings or specification.

Bursting discs shall be inspected in accordance with prEN ISO 4126-2.

I.2.6 Marking

Bursting discs shall be certified and marked in accordance with prEN ISO 4126-2.

Other pressure protection devices shall be marked with this EN number 13458.

Annex J (informative)

Increased material property for austenitic stainless steel

The Pressure Equipment Directive stipulates essential safety requirements for ensuring that a material is suitable for pressure equipment. However within ADR, for austenitic steels, the specified minimum values according to the material standard may be exceeded by up to 15 % if these higher values are attested in the inspection certificate. This method has been used successful for a number of years.

K is the minimum value at 20 °C taken from the material standard.

Higher values of K may be used provided that the following conditions are met:

- the material manufacturer should guarantee compliance with this higher value, in writing, when accepting the order;
- the increased properties are verified by testing each rolled plate or coil of the material to be delivered;
- the increased properties are attested in the inspection certificate.

In the case of austenitic stainless steels the specified minimum value may be exceeded by up to 15 % provided this higher value is attested in the inspection certificate.

In addition, for austenitic stainless steel a strength value obtained in work hardened material may be used in the design provided this value and the requirement of 5.3.1 are maintained in the finished component. Requirements for welding of work hardened austenitic stainless steels are given in 5.6.4.3.

The value of E (Young's modulus) at 20 °C should be used in calculation.

Annex K (normative)

Base materials

Table K.1 — Pressure vessels

Specification No	Material Grade	Material Number	Heat treatment condition
EN 10028-4	X8Ni9	1,5662	HT 640 & HT 680
EN 10222-3	X8Ni9	1,5662	-
ASME SA 353/SA 353M	9 % Nickel	K81340	N + N + T
ASME SA 553/SA 553M	Type 1 (9 %) Nickel	K81340	Q & T
ASME SA 522/SA 522M	Type 1 (9 %) Nickel	K81340	N + N + T or Q + T
EN 10028-7	X2CrNi18-9	1,4307	-
EN 10028-7	X2CrNi19-11	1,4306	-
EN 10028-7	X2CrNiN18-10	1,4311	-
EN 10028-7	X5CrNiN19-9	1,4315	-
EN 10028-7	X5CrNi18-10	1,4301	-
EN 10028-7	X3CrNiMo17-12-2	1,4401	-
EN 10028-7	X2CrNiMo17-12-2	1,4404	-
EN 10028-7	X2CrNiMoN17-11-2	1,4406	-
EN 10028-7	X2CrNiMoN17-13-3	1,4429	-
EN 10222-5	X2CrNi18-9	1,4307	-
EN 10222-5	X5CrNi18-10	1,4301	-
EN 1022-5	X5CrNiMo17-12-2	1,4401	-
EN 10222-5	X2CrNiMo17-12-2	1,4404	-
EN 10088-3	X2CrNi19-11	1,4306	-
EN 10088-3	X2CrNiN18-10	1,4311	-
EN 10088-3	X5CrNi18-10	1,4301	-
EN 10088-3	X5CrNiMo17-12-2	1,4401	-
EN 10088-3	X2CrNiMo17-13-2	1,4404	-
EN 10088-3	X2CrNiMoN17-12-2	1,4406	-
EN 10088-3	X2CrNiMo17-13-3	1,4429	-
prEN 10216-5	X2CrNi19-11	1,4306	-
prEN 10216-5-prEN 10217-7	X5CrNi 18-10	1,4301	-
prEN 10216-5-prEN 10217-7	X2CrNiN 18-10	1,4311	-
prEN 10216-5-prEN 10217-7	X6CrNiTi 18-10	1,4541	-
prEN 10216-5-prEN 10217-7	X6CrNiNb 18-10	1,4550	-
prEN 10216-5-prEN 10217-7	X5CrNiMo 17-12-2	1,4401	-
prEN 10216-5-prEN 10217-7	X2CrNiMo 17-13-2	1,4404	-
prEN 10216-5-prEN 10217-7	X6CrNiMoTi 17-12-2	1,4571	-
prEN 10216-5-prEN 10217-7	X2CrNiMoN 17-13-3	1,4429	-
prEN 10216-5-prEN 10217-7	X2CrNiMo 18-14-3	1,4435	-
prEN 10216-5-prEN 10217-7	X2CrNiMo 17-13-3	1,4436	-
prEN 10216-5-prEN 10217-7	X2CrNiMoN 17-13-5	1,4439	-
ASME SA 479/SA 479M	304L	S30403	-
ASME SA 479/SA 479M	304	S30400	-
ASME SA 479/SA 479M	316L	S31603	-
ASME SA 479/SA 479M	316	S31600	-

Annex L (informative)

Other materials

NOTE Materials listed in this annex cannot be used without European approval of pressure equipment materials (EAMs) or Particular material appraisal (PMA).

Table L.1 — Piping and pipe fittings

NOTE Piping and pipe fittings to ASTM standards are seamless.

Specification No.	Material grade	Material number
ASTM A 182/A 182M	F304L	S30403
ASTM A 182/A 182M	FP304	S30400
ASTM A 182/A 182M	F316L	S31603
ASTM A 182/A 182M	F316	S31600
ASTM A 216/A 213M	TP304L	S30403
ASTM A 216/A 213M	TP304	S30400
ASTM A 216/A 213M	TP316L	S31603
ASTM A 231/A 213A	TP316	S31600
ASTM A 249/A 249M	TP316	S31600
ASTM A 249/A 249M	TP304L	S30403
ASTM A 249/A 249M	TP304	S30400
ASTM A 249/A 249M	TP316L	S31603
ASTM A 249/A249M	TP316	S31600
ASTM A 269	TP304L	S30403
ASTM A 269	TP304	S30400
ASTM A 269	TP316L	S31603
ASTM A 269	TP316	S31600
ASTM A 276	304L	S30403
ASTM A 276	304	S30400
ASTM A 276	316L	S31603
ASTM A 276	316	S31600
ASTM A 312/A 312M	TP304L	S30403
ASTM A 312/A 312M	TP304	S30400
ASTM A 312/A 312M	TP316L	S31603
ASTM A 312/A 312M	TP316	S31600
ASTM A 312/A 312M	TP321	S32100
ASTM A 403/A 403M	WP304L	S30403
ASTM A 403/A 403M	WP304	S30400
ASTM A 403/A 403M	WP316L	S31603
ASTM A 403/A 403M	WP316	S31600
ASTM A 632	TP304L	S30403
ASTM A 632	TP304	S30400
ASTM A 632	TP316L	S31603
ASTM A 632	TP316	S31600
ASTM A 733	TP304L	S30403
ASTM A 733	TP304	S30400
ASTM A 733	TP316L	S31603
NFA 49117	TUZ2CN18-10	-
NFA 49147	TUZ2CN18-10	-

Annex ZA (informative)

Clauses of this European Standard addressing essential requirements or other provisions of EU directives

This European Standard has been prepared under a mandate given to CEN by the European Commission and the European Free Trade Association and supports essential requirements of EU Directive 97/23/EC (PED).

WARNING Other requirements and other EU Directives may be applicable to the product(s) falling within the scope of this standard.

Compliance with the clauses of this standard given in Table ZA.1 provides one means of conforming with the specific essential requirements of the Directive concerned and associated EFTA regulations.

Table ZA.1 — Clauses this European Standard addressing essential requirements of EU Directive 97/23/EC

Clauses of this European Standard	Nature of requirement	Annex I of PED Essential safety requirements
4.1	Adequate strength based on calculation methods	2.2.2
4.2.3, annex B	Adequate strength	2.2.1
4.2.5	means of examination	2.4. c)
4.2.6	safety accessories	2.11
4.2.6	Pressure relief	7.3
4.2.7.2, 4.2.8	filling and discharge	2.9
4.3.2, 4.3.3, 4.3.6, 4.3.7	allowable stresses with regard to foreseeable failure modes	2.2.3 a)
4.3.2.2	allowable stress	7.1
4.3.2.3	joint coefficients	7.2
4.3.2.4	Appropriate safety coefficients	2.1
4.3.6	design by formula	2.2.3 b)
4.3.7	design by analysis	2.2.3 b)
5	manufacturing process	3.1
5.3, 5.4	heat treatment	3.1.4
5.6, 6.3	permanent joining	3.1.2
6, annex B	Inspection and testing	3.2.1
6.1.1	traceability	3.1.5
6.5	final assessment	3.2.2
6.5	Hydrostatic test pressure	7.4
Annex A	design by analysis	2.2.3 a)

Bibliography

EN 970:1997, *Non destructive examination of fusion welds – Visual examination.*

EN 288-1:1992, *Specification and qualification of welding procedures for metallic materials – Part 1: General rules for fusion welding.*

EN 288-2:1992, *Specification and approval of welding procedures for metallic materials – Part 2: Welding procedure specification for arc welding.*

EN 1708-1:1999, *Basic weld joint details in steels – Part 1: Pressurized components.*

BSI — British Standards Institution

BSI is the independent national body responsible for preparing British Standards. It presents the UK view on standards in Europe and at the international level. It is incorporated by Royal Charter.

Revisions

British Standards are updated by amendment or revision. Users of British Standards should make sure that they possess the latest amendments or editions.

It is the constant aim of BSI to improve the quality of our products and services. We would be grateful if anyone finding an inaccuracy or ambiguity while using this British Standard would inform the Secretary of the technical committee responsible, the identity of which can be found on the inside front cover. Tel: +44 (0)20 8996 9000. Fax: +44 (0)20 8996 7400.

BSI offers members an individual updating service called PLUS which ensures that subscribers automatically receive the latest editions of standards.

Buying standards

Orders for all BSI, international and foreign standards publications should be addressed to Customer Services. Tel: +44 (0)20 8996 9001. Fax: +44 (0)20 8996 7001. Email: orders@bsi-global.com. Standards are also available from the BSI website at <http://www.bsi-global.com>.

In response to orders for international standards, it is BSI policy to supply the BSI implementation of those that have been published as British Standards, unless otherwise requested.

Information on standards

BSI provides a wide range of information on national, European and international standards through its Library and its Technical Help to Exporters Service. Various BSI electronic information services are also available which give details on all its products and services. Contact the Information Centre. Tel: +44 (0)20 8996 7111. Fax: +44 (0)20 8996 7048. Email: info@bsi-global.com.

Subscribing members of BSI are kept up to date with standards developments and receive substantial discounts on the purchase price of standards. For details of these and other benefits contact Membership Administration. Tel: +44 (0)20 8996 7002. Fax: +44 (0)20 8996 7001. Email: membership@bsi-global.com.

Information regarding online access to British Standards via British Standards Online can be found at <http://www.bsi-global.com/bsonline>.

Further information about BSI is available on the BSI website at <http://www.bsi-global.com>.

Copyright

Copyright subsists in all BSI publications. BSI also holds the copyright, in the UK, of the publications of the international standardization bodies. Except as permitted under the Copyright, Designs and Patents Act 1988 no extract may be reproduced, stored in a retrieval system or transmitted in any form or by any means – electronic, photocopying, recording or otherwise – without prior written permission from BSI.

This does not preclude the free use, in the course of implementing the standard, of necessary details such as symbols, and size, type or grade designations. If these details are to be used for any other purpose than implementation then the prior written permission of BSI must be obtained.

Details and advice can be obtained from the Copyright & Licensing Manager. Tel: +44 (0)20 8996 7070. Fax: +44 (0)20 8996 7553. Email: copyright@bsi-global.com.