

Mechanical tests for post-tensioning systems

The European Standard EN 13391:2004 has the status of a
British Standard

ICS 91.080.40

National foreword

This British Standard is the official English language version of EN 13391:2004. It supersedes BS 4447:1973 which is withdrawn.

The UK participation in its preparation was entrusted by Technical Committee B/525, Building and civil engineering structures, to Subcommittee B/525/2, Structural use of concrete, which has the responsibility to:

- aid enquirers to understand the text;
- present to the responsible international/European committee any enquiries on the interpretation, or proposals for change, and keep the UK interests informed;
- monitor related international and European developments and promulgate them in the UK.

A list of organizations represented on this subcommittee can be obtained on request to its secretary.

Additional information

Attention is drawn also to ETAG 013 (June 2002), *Guideline for European Technical Approval of post-tensioning kits for prestressing of structures (these are commonly called Post-Tensioning Systems)*, available from EOTA, Kunstlaan 40 Avenue des Arts, B-1040 Brussels (see <http://www.eota.be>).

Cross-references

The British Standards which implement international or European publications referred to in this document may be found in the *BSI Catalogue* under the section entitled “International Standards Correspondence Index”, or by using the “Search” facility of the *BSI Electronic Catalogue* or of British Standards Online.

This publication does not purport to include all the necessary provisions of a contract. Users are responsible for its correct application.

Compliance with a British Standard does not of itself confer immunity from legal obligations.

Summary of pages

This document comprises a front cover, an inside front cover, the EN title page, pages 2 to 21 and a back cover.

The BSI copyright notice displayed in this document indicates when the document was last issued.

Amendments issued since publication

Amd. No.	Date	Comments

This British Standard was published under the authority of the Standards Policy and Strategy Committee on 19 October 2004

© BSI 19 October 2004

ISBN 0 580 44624 7

EUROPEAN STANDARD

EN 13391

NORME EUROPÉENNE

EUROPÄISCHE NORM

March 2004

ICS 91.080.40

English version

Mechanical tests for post-tensioning systems

Essais mécaniques concernant les procédés de
précontrainte par post-tension

Mechanische Prüfungen für Spanverfahren it
nachträglichem Verbund

This European Standard was approved by CEN on 3 November 2003.

CEN members are bound to comply with the CEN/CENELEC Internal Regulations which stipulate the conditions for giving this European Standard the status of a national standard without any alteration. Up-to-date lists and bibliographical references concerning such national standards may be obtained on application to the Central Secretariat or to any CEN member.

This European Standard exists in three official versions (English, French, German). A version in any other language made by translation under the responsibility of a CEN member into its own language and notified to the Central Secretariat has the same status as the official versions.

CEN members are the national standards bodies of Austria, Belgium, Cyprus, Czech Republic, Denmark, Estonia, Finland, France, Germany, Greece, Hungary, Iceland, Ireland, Italy, Latvia, Lithuania, Luxembourg, Malta, Netherlands, Norway, Poland, Portugal, Slovakia, Slovenia, Spain, Sweden, Switzerland and United Kingdom.



EUROPEAN COMMITTEE FOR STANDARDIZATION
COMITÉ EUROPÉEN DE NORMALISATION
EUROPÄISCHES KOMITEE FÜR NORMUNG

Management Centre: rue de Stassart, 36 B-1050 Brussels

Contents

Page

Foreword.....	3
1 Scope	4
2 Normative references	4
3 Terms, definitions and symbols	4
3.1 Definitions.....	4
4 Tests and requirements for post-tensioning anchorages	6
4.1 General.....	6
4.1.1 Purpose.....	6
4.1.2 Specification of system.....	6
4.1.3 Laboratory, testing facility	6
4.1.4 Materials and components for the tests.....	6
4.1.5 Types of test.....	6
4.2 Testing of systems with mechanical anchorages	7
4.2.1 Static load test with tendon-anchorage assembly	7
4.2.2 Fatigue test with tendon-anchorage assembly.....	9
4.2.3 Load transfer test.....	10
4.3 Testing of systems with bond anchorage	11
4.3.1 Static load test with bond anchorage	11
4.3.2 Fatigue load test with bond anchorage	12
5 Supplementary tests.....	12
5.1 General.....	12
5.2 Multiple stressing test	13
5.3 Friction test.....	13
5.4 Groutability test.....	13
5.5 Deviation test for anchorages	13
5.6 Deviation test for unbonded external tendons	13
6 Test report	13
Annex A (informative) Figures	14
Bibliography	21

Foreword

This document (EN 13391:2004) has been prepared by Technical Committee CEN/TC 250 "Structural Eurocodes", the secretariat of which is held by BSI.

This European Standard shall be given the status of a national standard, either by publication of an identical text or by endorsement, at the latest by August 2004, and conflicting national standards shall be withdrawn at the latest by August 2004.

This European Standard was prepared by Working Group 1 of CEN/TC 250/SC 2 "Design of concrete structures". The standard supplements ENV 1992-1-1, ENV 1992-2 and the "European Technical Approval Guideline of post-tensioning kits for prestressing of structures (these are commonly called Post-Tensioning Systems)", ETAG 013.

Annex A is informative.

According to the CEN/CENELEC Internal Regulations, the national standards organizations of the following countries are bound to implement this European Standard: Austria, Belgium, Cyprus, Czech Republic, Denmark, Estonia, Finland, France, Germany, Greece, Hungary, Iceland, Ireland, Italy, Latvia, Lithuania, Luxembourg, Malta, Netherlands, Norway, Poland, Portugal, Slovakia, Slovenia, Spain, Sweden, Switzerland and United Kingdom.

1 Scope

This European Standard specifies the test procedures for the anchorages and couplings of post-tensioning systems. This standard is to be used in conjunction with the relevant European Standards ENV 1992-1-1 and ENV 1992-2 and others for pertaining to prestressed concrete structures.

The test results should be used for the acquisition of the Technical Approval of the specified post-tensioning system.

For unbonded tendons additional tests and requirements are needed and these are not covered in the present scope of this standard.

2 Normative references

Not applicable.

3 Terms, definitions and symbols

For the purposes of this European Standard, the following terms, definitions and symbols apply.

3.1 Definitions

3.1.1

Anchorage

mechanical device, usually consisting of several components designed to reliably and safely retain the force in the stressed tendon and to transmit it to the concrete. Anchorages can be either of the two types specified below:

- ¾ Stressing anchorage: an anchorage located at the end of a tendon which can be used for stressing. It is exposed until grouting has been carried out and the anchorage sealed.
- ¾ Fixed anchorage: an anchorage which is not used for tendon stressing.

3.1.2

Anchorage zone

local zone in the structure through which the prestressing force is transferred to the structure via the anchorage

3.1.3

Bursting reinforcement

reinforcement in the anchorage zone to resist transverse tensile forces due to the introduction of prestressing force into the structure

3.1.4

Coupling

device to join tendons

3.1.5

Duct (sheathing)

enclosure in which the prestressing steel is placed and which temporarily or permanently allows relative movement between the prestressing steel and surrounding concrete. The remaining void within the duct can

be subsequently filled with cementitious grout or other suitable material to protect the prestressing steel against corrosion

3.1.6 Prestressing

controlled generation of permanent forces and deformations in a structural concrete member to counteract the stresses arising from dead and live loads and/or due to shrinkage etc.

3.1.7 Post-tensioning system

arrangement of tendon and anchorages to carry out post-tensioning

3.1.8 Tendon

one or a number of prestressing steel elements e.g. wire, strand, bar, etc. Tendons can be either:

- ¾ Bonded: following stressing the tendon is grouted, thereby creating bond between the prestressing steel, grout, duct and concrete; or
- ¾ Unbonded: bond between tendon and concrete is prevented with the tensile force of the stressed tendon being permanently transferred to the concrete by the anchorages and deviators only

3.1.9 Tendon-anchorage assembly

connection between tendon and anchorage

Symbols

A_{pk}	characteristic cross-sectional area of the tendon
A_{pm}	actual mean cross-sectional area of the tendon
F_{pk}	characteristic ultimate resisting force of prestressing steel of tendon; $F_{pk} = A_{pk} f_{pk}$
F_{pm}	calculated ultimate resisting force of prestressing steel of tendon; $F_{pm} = A_{pm} f_{pm}$
F_{Tu}	measured ultimate force of tendon-anchorage assembly
F_u	measured ultimate force in load transfer test
max F	upper force in the dynamic load test with tendon-anchorage assembly
min F	lower force in the dynamic load test with tendon-anchorage assembly
F	force range in the dynamic load test; $F = \max F - \min F$
f_{ck}	characteristic compressive strength of concrete at 28 days
$f_{ck,o}$	minimum characteristic compressive strength of concrete at which full prestressing is planned on site
$f_{cm,e}$	mean compressive strength of concrete of specimen at final test to failure in the load transfer test
$f_{cm,o}$	mean compressive strength of concrete at which full prestressing is planned on site
f_{pk}	characteristic tensile strength of prestressing steel

f_{pm}	actual mean tensile strength of prestressing steel used for test (mean of the result of minimum three tests)
t	time
w	crack width measured in the load transfer test
ϵ_{Tu}	elongation of prestressing steel on free length of tendon at ultimate force F_{Tu}

4 Tests and requirements for post-tensioning anchorages

4.1 General

4.1.1 Purpose

It is the purpose of the test procedures to standardize the required mechanical tests for post-tensioning systems. The stipulated requirements pertain to the described tests. Figures are given in annex A.

4.1.2 Specification of system

Prior to testing, the principal details of the prestressing system shall be made known as far as they relate to the tests, e.g. by the technical report or specification of system.

4.1.3 Laboratory, testing facility

Generally, the tests shall be performed by an independent and notified laboratory. However, facilities provided by the applicant may be used, if the tests are executed under the surveillance and responsibility of such a laboratory.

4.1.4 Materials and components for the tests

All tests should be performed with the type and grade of prestressing steel and with the anchorage components as intended for application. If the anchorage to be used requires mechanical treatment of the prestressing steel, the effects of such treatment should be considered and justified.

The geometrical and mechanical properties of anchorage components as well as the tolerance range of dimensions shall be made known.

For the load transfer test the grade of concrete for the application of the post-tensioning system shall be as defined in the specifications. The grade of concrete is specified by its characteristic compressive concrete strength at 28 days, f_{ck} , this being determined in accordance with relevant standards. The minimum concrete compressive strength at which full prestress can be applied on site shall be specified. It can be defined either as the mean compressive strength $f_{cm,o}$ or as the minimum characteristic compressive strength, $f_{ck,o}$ of the concrete of the anchorage zone. These values are assumed to be related to each other by:

$$f_{ck,o} = f_{cm,o} - 8 \text{ MPa.}$$

(The properties of the concrete for the specimens are given in 4.2.3.2 and 4.2.3.3)

4.1.5 Types of test

The tests are performed according to the method of anchoring the prestressing steel. A distinction is made between:

- ¾ Anchorages formed by mechanical means: the prestressing steel is fixed to an anchorage element by means of mechanical devices such as wedges, button heads, threads, etc. Anchoring may also be achieved by forming the prestressing steel in a loop around a steel element, etc.
- ¾ Bond anchorages: the prestressing steel is anchored in the concrete before the stressing force is applied to the tendon. The anchoring may either be achieved by bond alone or partially by a mechanical device and partially by bond.

The tests pertain to tendon-anchorage assemblies and anchorage zones of bonded and unbonded, interior or exterior tendons. Couplings, which connect two tendons to form a continuous tendon, shall be tested in the same way as anchorages with mechanical means.

In carrying out a test items may also be combined, for instance:

- ¾ mechanical anchorage – coupling – mechanical anchorage.
- ¾ mechanical anchorage – anchorage by bond.

Three types of tests are to be performed: static load test, fatigue test and load transfer test.

4.2 Testing of systems with mechanical anchorages

4.2.1 Static load test with tendon-anchorage assembly

4.2.1.1 General

The aim of the test is to assess the performance of the tendon-anchorage assembly and to determine any decrease of the breaking load of the prestressing steel due to the influence of the anchorage. The test also pertains to couplers.

4.2.1.2 Test specimen

The tendon to be tested shall be assembled according to the envisaged application, using all components necessary for anchoring the tendon. Components for testing shall be randomly selected. The geometrical configuration of the individual tensile elements in the specimen shall be identical to that of the specified tendon assembly given in the European Technical Approval (ETA). The following data of the tensile elements shall be established :

- ¾ main mechanical and geometrical properties of the tensile elements, including the actual ultimate strength;
- ¾ calculated actual ultimate force F_{pm} ;
- ¾ mean total cross-section of tensile elements A_{pm} ;
- ¾ surface characteristics of tensile elements.

Relevant geometrical and mechanical properties of anchorage components shall also be determined. The free length of the tensile elements in the tendon specimen to be tested shall not be less than 3,0 m, except for bar tendons with a minimum length of 1,0 m. If more than one grade of tensile elements of the same type is to be used with the same type of anchorage, the tests shall be performed using the grade with the highest characteristic tensile strength, and/or load capacity.

4.2.1.3 Test procedure

The tendon specimen is mounted in the test rig or testing machine, observing the same geometrical configuration of the individual tensile elements in the specimen to that specified in the ETA.

The tendon is stressed at one end with representative equipment comparable to the one used on construction site, and specified in the ETA, in steps corresponding to 0,2, 0,4, 0,6 and 0,8 of the characteristic tensile strength of the tensile elements. The load is increased at a constant rate corresponding to about 100 MPa per minute. At 0,8 level, the load is transferred from the equipment to the anchorage and test rig. It is then held constant at 0,8 level for one and two hours for internal and external tendons, respectively. For external tendons, the load is then reduced to 0,2 level. Subsequently, the load is gradually increased for both tendon types with the test rig to failure at a maximum strain rate of 0,002 per minute.

The uncertainty of values measured with the measuring equipment shall be within +1 %. Loads shall be maintained with a maximum tolerance of +2 %. The load measured in the jack shall be adjusted for estimated friction losses in the anchorages to assure that the specified load has been applied to the anchor head used for measurement.

4.2.1.4 Measurements and observations

The following measurements and observations shall be made and recorded:

- ¾ Compliance checking of the components with ETA specifications (materials, machining, geometry, hardness, etc).
- ¾ Relative load- and time-dependent displacement s of the tensile elements with respect to the anchorage on at least two elements (see Figure A.1).
- ¾ Relative load- and time-dependent displacement r between the individual components of the anchorage on at least two components, e.g. wedges (see Figure A.1), or as applicable for other methods of anchoring the tensile elements.
- ¾ For external tendons only, deformations of one anchor head in circumferential direction t , and deflections of the head relative to the supporting plate z , (see Figure A.2), in seven measurement series as follows:
 - 1) At 20 % level.
 - 2) At 40 % level.
 - 3) At 80 % level between time t_0 , and $t_0 + 10$ minutes where t_0 is time when 80 % level was reached.
 - 4) At 80 % level between time $t_0 + 30$ minutes and $t_0 + 40$ minutes.
 - 5) At 80 % level between time $t_0 + 60$ minutes and $t_0 + 70$ minutes.
 - 6) At 80 % level between time $t_0 + 120$ minutes and $t_0 + 130$ minutes.
 - 7) At 20 % level.
- ¾ Complete load-elongation diagram, continuously recorded during the test.
- ¾ Elongation of the tensile elements ϵ_{Tu} on free length at measured maximum force F_{Tu} .
- ¾ Measured maximum force F_{Tu} .
- ¾ Location and mode of failure.

- ¾ Examination of components after dismantling, photographic documentation, comments, including residual deformations of the anchor head.

4.2.2 Fatigue test with tendon-anchorage assembly

4.2.2.1 General

The aim of the test is to determine the capacity of the tendon-anchorage assembly under load fluctuations, as an indication of the reliability and durability of the assembly.

4.2.2.2 Test specimen

The type of specimen corresponds to 4.2.1.2, see also Figure A.1. At least at one tendon end the anchorage with all components which deviate the tensile elements in the anchorage and at the entrance into the duct shall be provided identical to the assembly specified in ETA, with no change to their geometry, their material, and their machining. These components which deviate the tensile elements shall be kept at a fixed distance from the anchorage to duplicate the actual deviation and the relative movements to the tensile elements. If both tendon ends have such anchorage details as specified above, the specimen shall count as two tests.

If more than one grade of tensile elements of the same type is to be used with the same type of anchorage, the tests shall be performed with tensile elements using the grade with the highest characteristic tensile strength, and/or largest load capacity.

Where possible the tendon shall be tested with the complete number of tensile elements installed. However, the number of tensile elements in the tendon-anchorage assembly to be tested may be reduced as follows. For a tendon of n tensile elements, the reduced number n' of tensile elements installed for the test shall comply with:

$$\frac{3}{4} \quad \text{if } n \geq 12: \quad n' = n/2$$

$$\frac{3}{4} \quad \text{if } n < 12: \quad n' = 6 + (n - 12)/3$$

The tensile elements with the most severe angular deviation from the tendon axis shall be included.

The concrete strength at the start of the fatigue test shall not exceed $f_{cm,o}$.

4.2.2.3 Test procedure

The test shall be performed in a tensile testing machine with the pulsator at a constant load frequency of not more than 10 Hz, and with a constant upper load of 65 % of the characteristic strength of the tensile elements. Range of loads $F = \max F - \min F$ shall be maintained constant throughout the testing, at levels corresponding to 80 MPa stress amplitude in the tensile elements for 2 million cycles. On its free length the specimen shall be without duct and filling material.

The specimen shall be tested in such a way that secondary oscillations are precluded. When assembling the specimen and fitting it in the testing machine, special care should be taken to ensure that the load is evenly distributed to all the tensile elements of the tendon.

4.2.2.4 Measurements and observations

The following measurements and observations shall be made and recorded :

- ¾ Compliance checking of the components with European Technical Approval specifications (materials, machining, geometry, hardness, etc).

- ¾ Relative displacement between tensile elements and individual anchorage components as well as between the anchorage components, dependent on load and on number of load cycles on at least two tensile elements (Figure A.1).
- ¾ Examination of anchorage components and tensile elements after test with respect to fatigue damage and deformation.
- ¾ Record of fracture location and number of tensile elements which have failed by fatigue, as a function of the number of load cycles.
- ¾ Examination of components after dismantling, photographic documentation, comments.
- ¾ The slip of ends of the tensile elements relative to the concrete shall be measured.

4.2.3 Load transfer test

4.2.3.1 General

With the load transfer test, the reliable transfer of the prestressing force from the anchorage to the concrete shall be verified.

4.2.3.2 Test specimen

The test specimen is schematically shown in Figure A.4. The specimen shall contain those anchorage components and bursting reinforcement which will be embedded in the structural concrete, and their arrangement has to comply with the intended application and with the specification as per the ETA. Components shall be randomly selected.

The test specimen shall be a concrete prism for testing in axial compression. Its concrete cross-section $A_c = a \cdot b$ shall correspond to the minimum cross-section in axial compression for the particular tendon and concrete strength class in the structure permitted by the ETA applicant's guide. The dimensions a and b of the concrete prism shall be specified in the European Technical Approval as reference dimensions.

The height h of specimen shall be at least twice the longer of the two side lengths a or b , see Figure A.4. The height of the lower, nominally reinforced part of the specimen shall be at least $0,5 h$ long.

The part of the specimen containing the anchorage components shall be provided with bursting reinforcement of the same magnitude and configuration as specified for the particular system and tendon in the European Technical Approval. For the assembly of the bursting reinforcement, auxiliary reinforcement may be used. It will not be part of the technical approval if the following conditions are met:

- ¾ longitudinal bars with a total cross-section of $0,003 A_c$,
- ¾ stirrups, uniformly distributed along the height of specimen, with 50 kg steel/m^3 concrete.

The concrete of the test specimen shall correspond to normal concrete used for prestressed concrete structures with respect to materials, composition, compaction and its characteristic strength f_{ck} . After casting the specimen shall be de-moulded after one day and then moist-cured until testing. The test cylinders or cubes cast for the determination of the compressive strength of concrete shall be cured in the same manner.

4.2.3.3 Test procedure

The specimen shall be mounted in a calibrated test rig or testing machine. The load shall be applied to the specimen on an area which simulates the loading condition in a complete anchorage.

The load is increased in steps: $0,2 F_{pk}$, $0,4 F_{pk}$, $0,6 F_{pk}$ and $0,8 F_{pk}$ (Figure A.5). After reaching the load $0,8 F_{pk}$ at least ten slow load cycles are to be performed, with $0,8 F_{pk}$ and $0,12 F_{pk}$ being the upper and the lower load

limits, respectively. The necessary number of load cycles depends upon stabilisation of strain readings and crack widths as described below. Following cyclic loading, the specimen shall be loaded continuously to failure.

During cyclic loading measurements shall be taken at the upper and lower loads of several cycles in order to decide whether satisfactory stabilisation of strains and widths of cracks is being attained. Cyclic loading shall be continued to n cycles until stabilisation is satisfactory, Figure A.5 shows the sequence of loading and measurements.

At the final test to failure the mean compressive strength of concrete of specimen shall be:

$$f_{cm,c} = f_{cm,0}$$

- ¾ Crack widths can be considered to have stabilised if their width under upper load complies with: $w_n - w_{n-4} \leq 1/3(w_{n-4} - w_0)$, $n \geq 10$
- ¾ Longitudinal and transverse strains can be considered to have stabilised if the increase of strain under the upper load complies with: $\epsilon_n - \epsilon_{n-4} \leq 1/3(\epsilon_{n-4} - \epsilon_0)$, $n \geq 10$

See Figure A.6 for details on how to assess stabilisation criteria.

4.2.3.4 Measurements and observations

The following measurements and observations shall be made and recorded:

- ¾ Compliance checking of the components with European Technical Approval specifications (materials, machining, geometry, hardness, etc).
- ¾ Longitudinal and transverse concrete strains on at least two side faces of the specimen in the region of maximum bursting effect under the upper and lower load, dependent on number of load cycles.
- ¾ Formation, width and propagation of cracks on the side faces of the specimen, as mentioned above.
- ¾ Visual inspection and/or measurement of deformation of anchorage components in contact with concrete.
- ¾ Location and mode of failure.
- ¾ Measured ultimate force F_u .
- ¾ Examination of components and specimen after testing, photographic documentation, comments.

Figure A.7 schematically shows the arrangement of the gauge points for the strain measurement on each side of the specimen, etc.

4.3 Testing of systems with bond anchorage

4.3.1 Static load test with bond anchorage

4.3.1.1 General

The aim of the test is to verify the reliable transfer of the prestressing force from the tendon to the concrete.

4.3.1.2 Test specimen

The bond anchorage and tendon shall be cast into a concrete block. The arrangement of the tensile elements, their geometrical shape, anchorage components, etc shall comply with the ETA. Components used for testing shall be randomly selected. The cross-section and side lengths, a and b of the specimen, should correspond to the values defined in 4.2.3.

The test specimen is shown schematically in Figure A.3. The specimen consists of two regions. One region contains the embedded bond anchorage, all the anchorage components and the bursting reinforcement. The other region contains the straight tendon with the duct which is not injected with filling material. The straight tendon length shall exceed the length of the longer side of the specimen.

The specimen shall be cast in a horizontal position. To allow for the detrimental effect due to setting of fresh concrete on bond, an additional concrete block of a height of about 500 mm below the specimen shall be cast integrally with the specimen. This additional block shall be removed before testing.

Identical requirements to 4.2.3.2 apply to the bursting reinforcement and the concrete regarding strength, de-moulding and curing, etc. All details of the tendon need to comply with the ETA.

4.3.1.3 Test procedure

The test procedure corresponds to 4.2.3.3 and Figure A.5. At the final test to failure the mean compressive strength of concrete in the specimen should be:

$$f_{cm,e} = 0,80 f_{cm,0}$$

The stabilisation criteria are identical with requirements in 4.2.3.3.

4.3.1.4 Measurement and observations

These shall correspond to 4.2.3.4. In addition the slip of ends of prestressing steel relative to the concrete shall be measured.

4.3.2 Fatigue load test with bond anchorage

4.3.2.1 Test specimen

As described in 4.3.1.2.

4.3.2.2 Test procedure

As described in 4.2.2.3.

4.3.2.3 Measurements and observations

As described in 4.2.2.4 and 4.3.1.4 accordingly.

5 Supplementary tests

5.1 General

To prove the reliability of a post-tensioning system and to make technical information available for its application on the construction site, it may be necessary to carry out supplementary tests. These may be omitted if justified because of sufficient experience with a system (see ETAG 013, E.3).

5.2 Multiple stressing test

If for the particular system it is planned to apply stage stressing and anchoring of the tendon to an incrementally increasing force with the same set of wedges, the effects of this procedure should be tested in single tensile element tests (see ETAG 013, E.3).

5.3 Friction test

The prestressing force should be established accurately at the required magnitude in every cross-section of the structure. Therefore the friction coefficient for computing losses should be known in advance.

Tests to predetermine the friction losses are not dealt with. Reference is to be made to ETAG 013, B.6.1.

5.4 Groutability test

If the reliability of the equipment for grouting, the components for grouting and venting connected with the conduit and if the reliable and complete filling of duct with grout has not yet been proved, groutability tests are advised. Groutability tests are not dealt with in this standard. Reference is to be made to the ETAG 013, B.6.2.

5.5 Deviation test for anchorages

If angular deviation of tendon axis from the prescribed one could exist, tests which incorporate maximum deviation angles should be performed.

5.6 Deviation test for unbonded external tendons

For post-tensioning with external unbonded tendons, devices for the voluntary deviation of the tendon may be used. Also involuntary deviations may occur. Supplementary tests on the deviated tendon may be necessary to prove the proper function of the tendon (prestressing steel and corrosion protection) at the deviation (see ETAG 013, B.5.2).

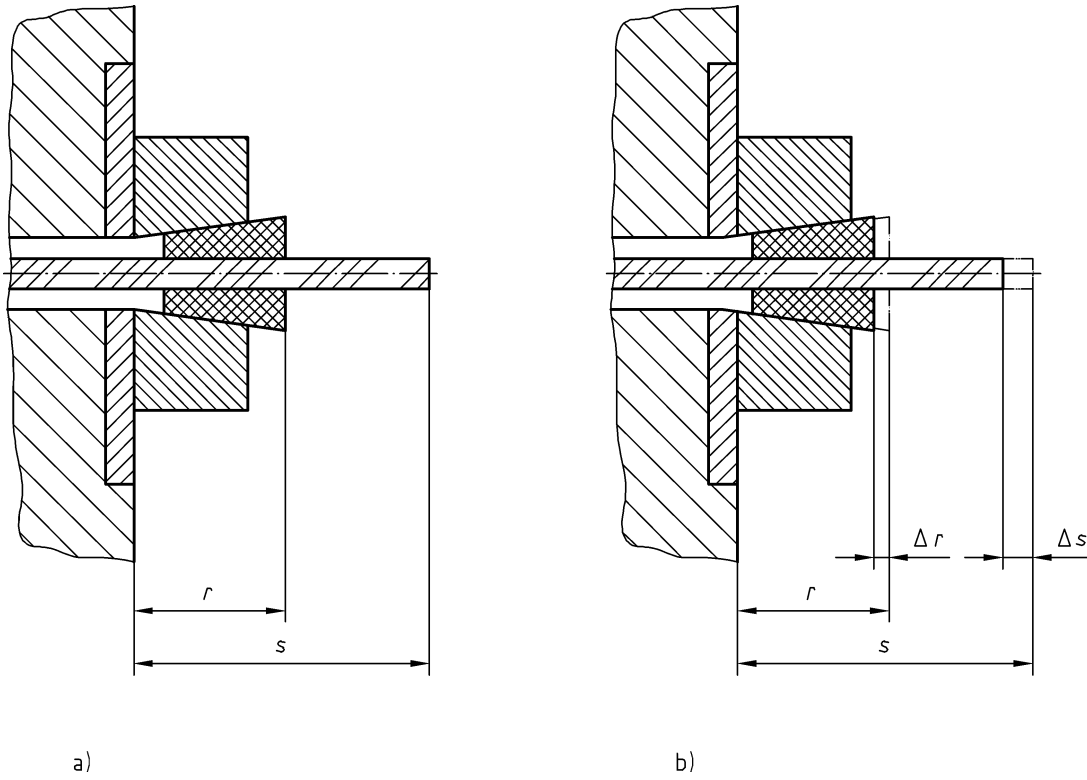
6 Test report

The test report shall include the following information:

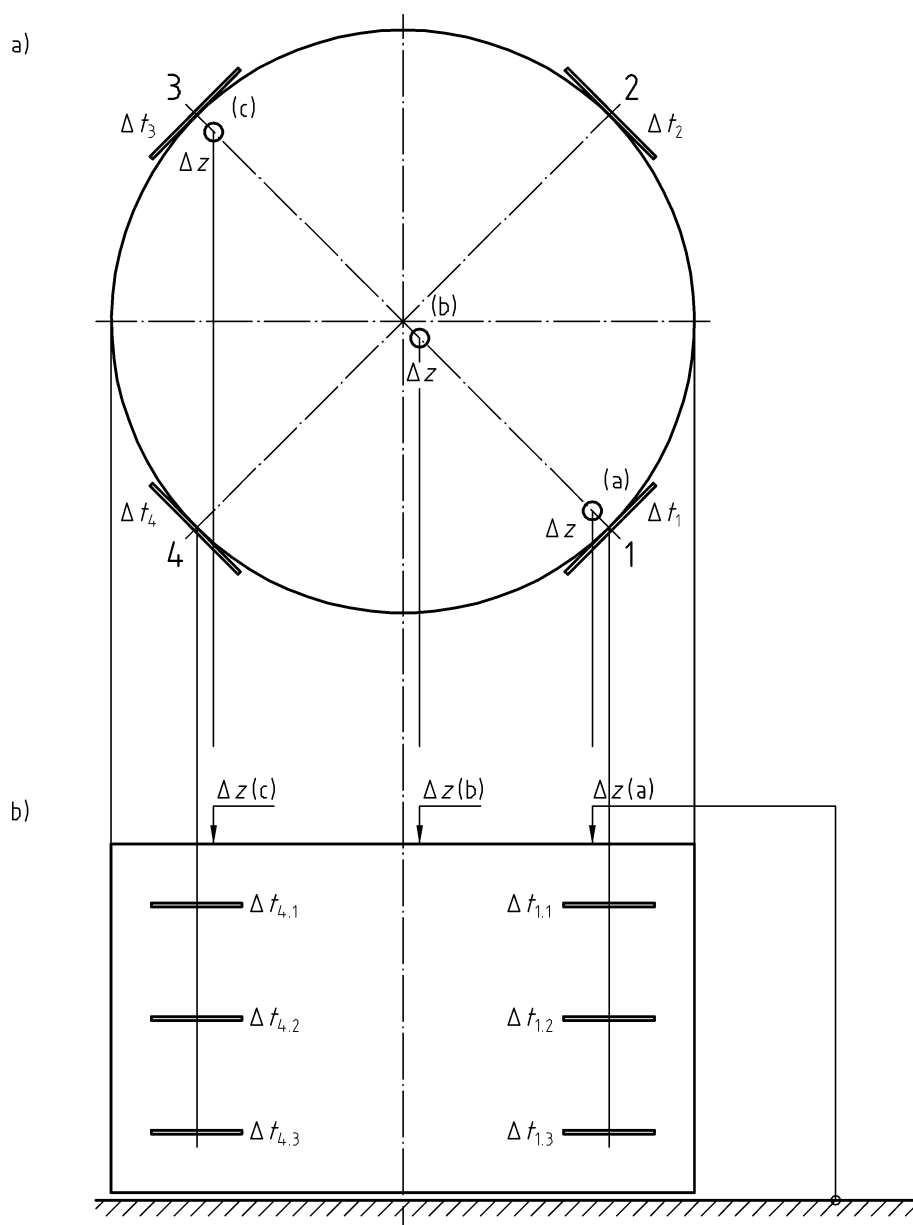
- ¾ A signed statement by the laboratory or body which has carried out or witnessed the tests that these tests have been carried out in accordance with this standard.
- ¾ Certificates of all relevant materials to confirm compliance with relevant specifications. Actual characteristics of components (mechanical, chemical, metallurgical, geometrical, etc as relevant) at time of testing, and source of manufacture. These include in particular tensile elements, anchorage components, ducts, filling material, reinforcement, and also concrete (or steel, masonry, or timber).
- ¾ Certificates of equipment and test machine calibration.
- ¾ Description and drawing of test specimen with actual dimensions.
- ¾ Description and drawing of test set-up and measuring equipment including calibration certificate.
- ¾ Description of detailed test procedure.
- ¾ Record of all measurements and observations.
- ¾ Photographs of test specimen prior, during, and after testing.
- ¾ Date and place of testing.
- ¾ Name and signature of person responsible for testing.

Annex A
(informative)

Figures

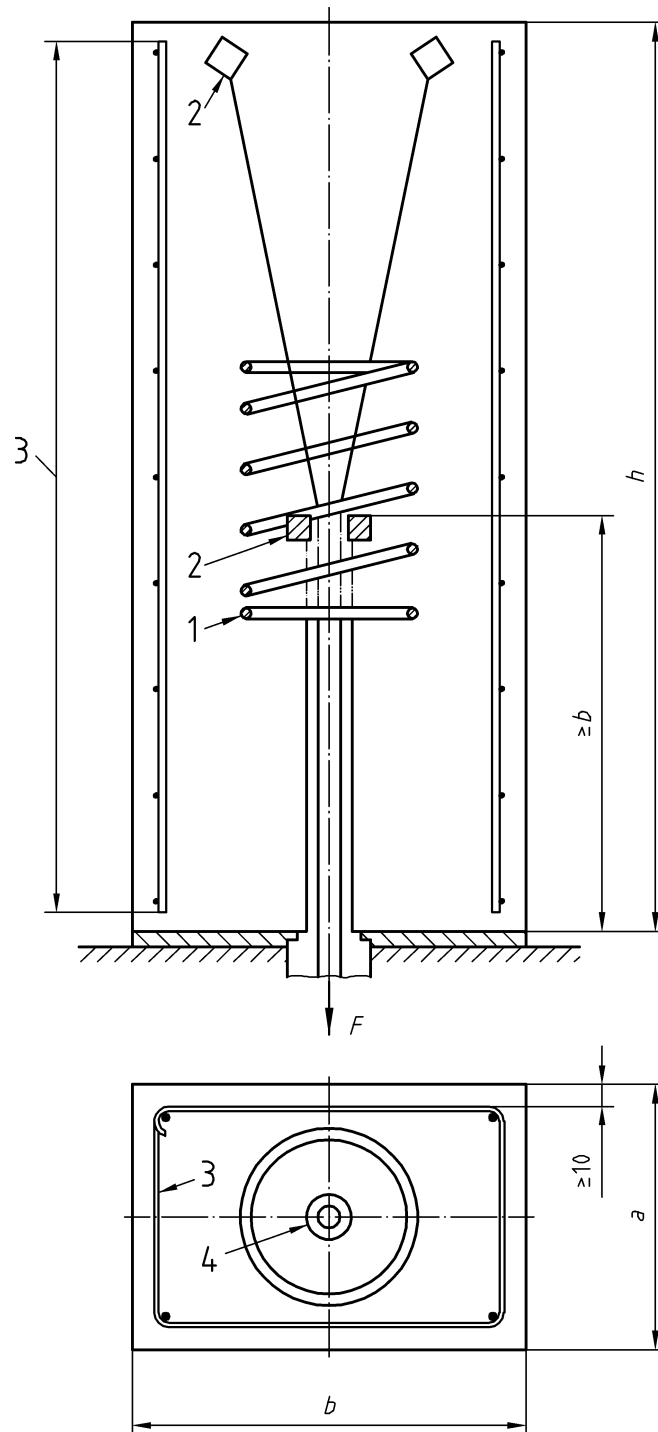


**Figure A.1 — Displacements during testing: (a) before locking; (b) after locking
(Shown for wedge anchorage, other methods of anchoring the tensile elements as applicable)**

**Key**

- a) Plan View of Anchor Head
 b) Elevation

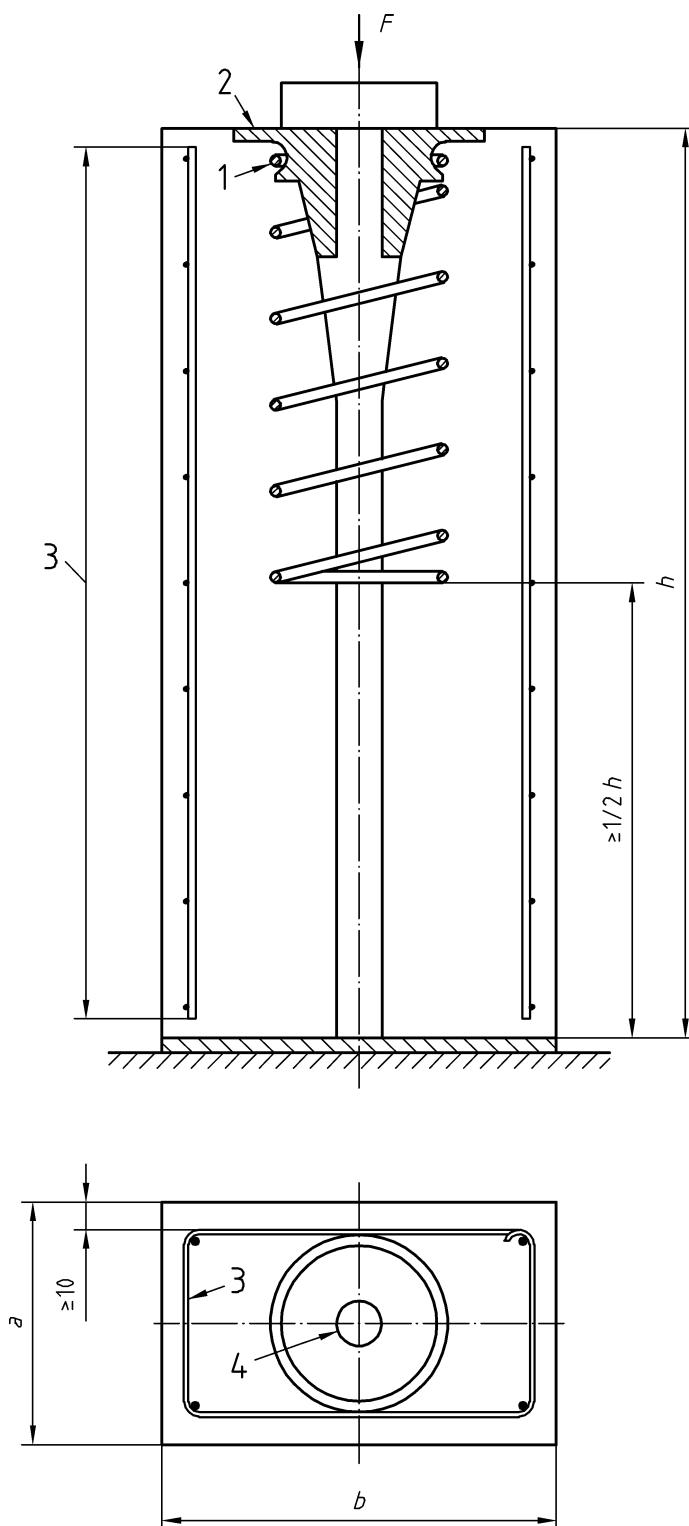
Figure A.2 — Deformation readings on anchor head of external tendon



Key

- | | | | |
|---|-----------------------------|---|-------------------------|
| 1 | bursting reinforcement | 3 | auxiliary reinforcement |
| 2 | actual anchorage components | 4 | duct |

Figure A.3 — Test specimen for load transfer test with bond anchorage

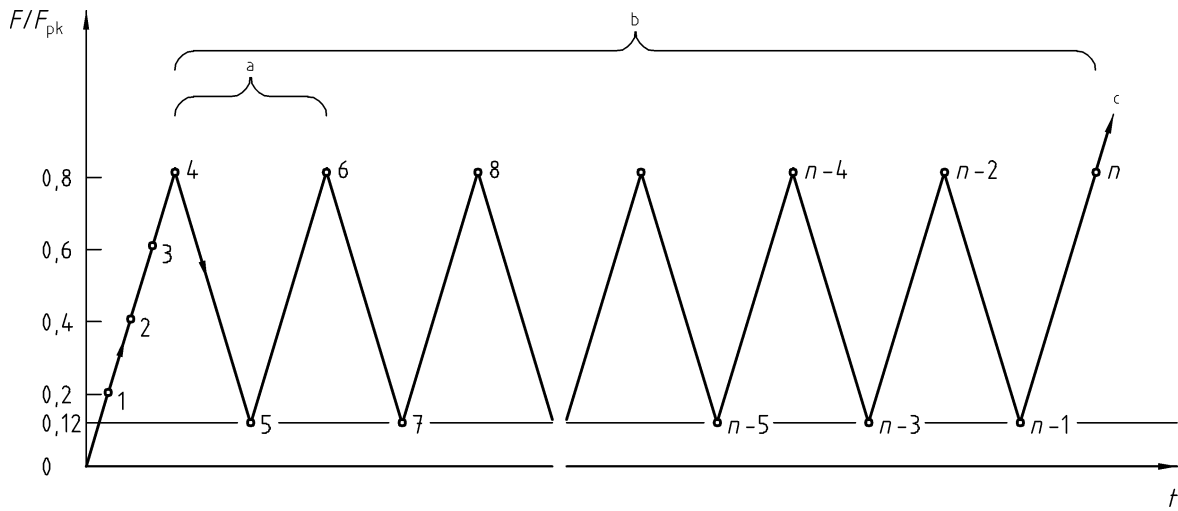


Key

- 1 bursting reinforcement
- 2 anchorage components

- 3 auxiliary reinforcement
- 4 empty duct

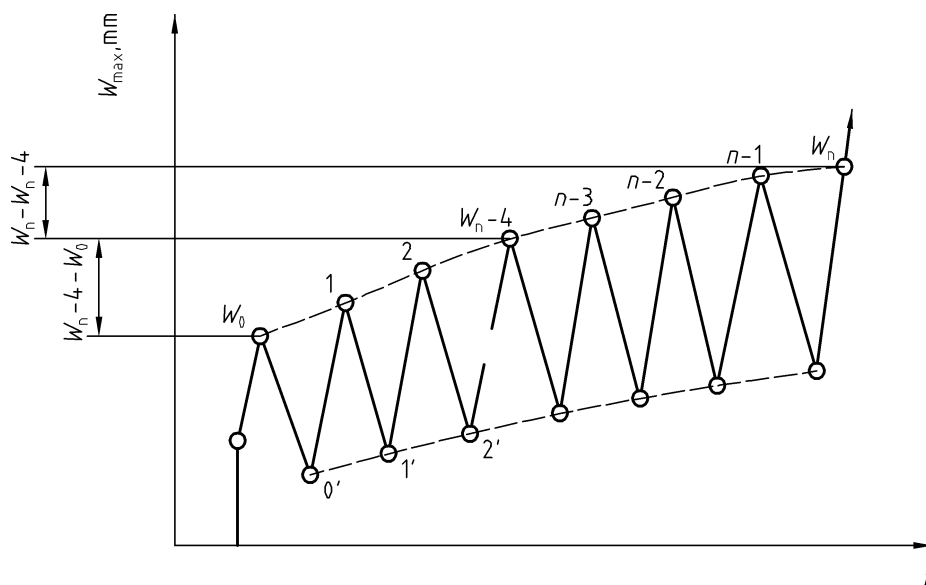
Figure A.4 — Test specimen for load transfer test



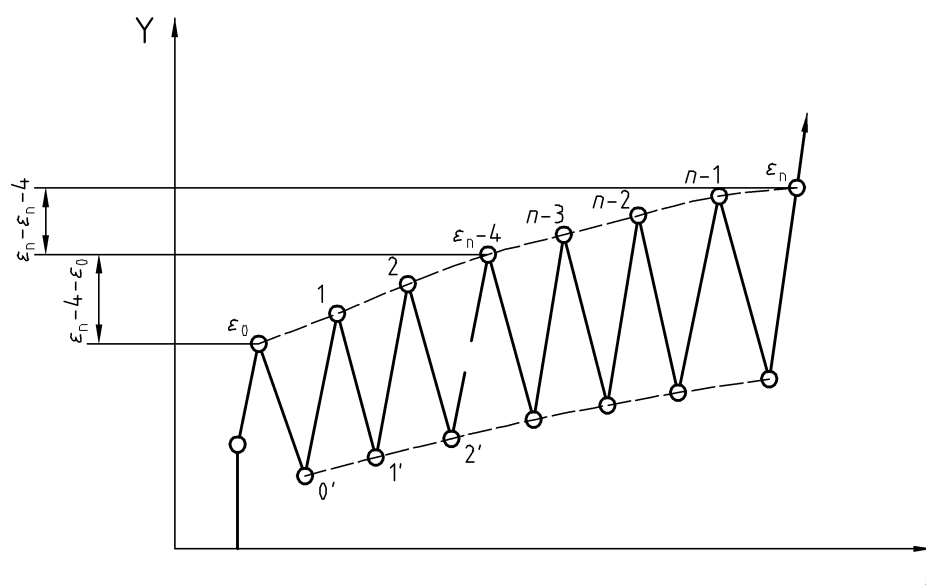
Key

- ▣ load points to measurements
- a 1 cycle
- b 10 cycles
- c to failure

Figure A.5 — Procedure of load transfer test



a)



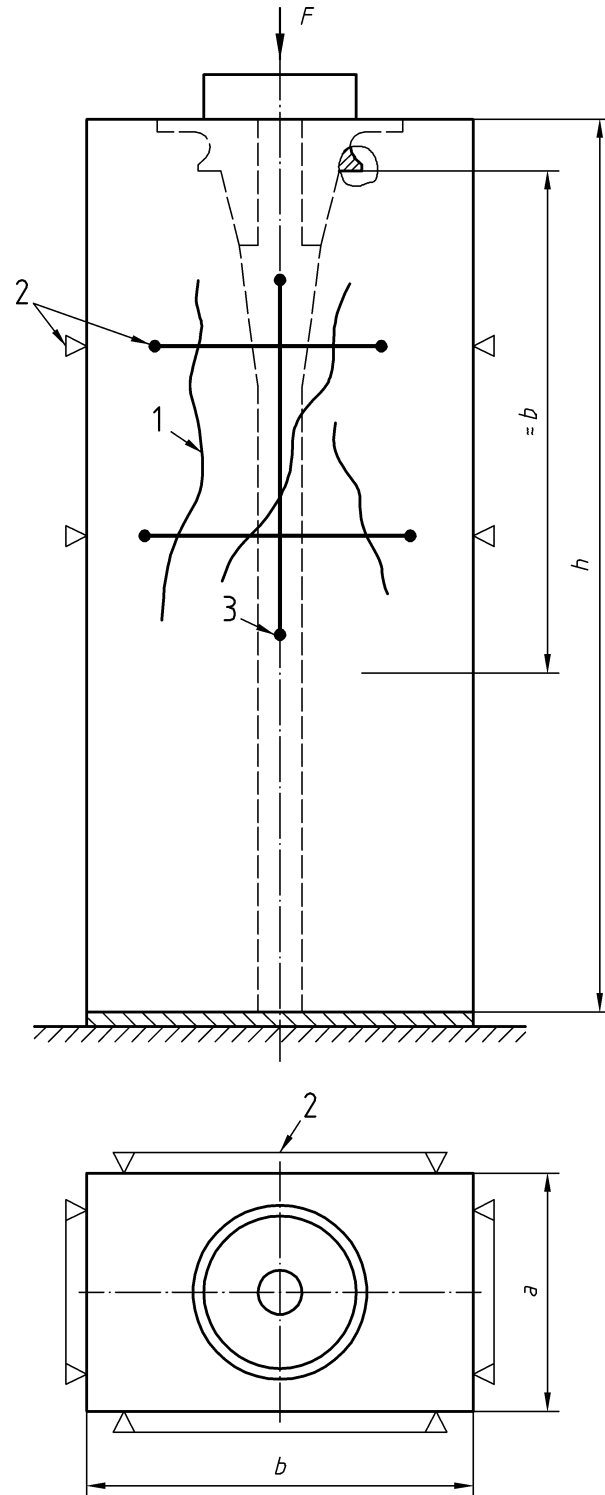
b)

Key

- a) Crack widths
- b) Strains

NOTE $A = \max_{\nu}$ and $\max_{\dot{t}}$ / resp.

Figure A.6 — Assessment of crack width and strain stabilisation



Key

- 1 cracks
- 2 for ϵ_t
- 3 for ϵ_v

- ϵ_t transverse strain
- ϵ_v vertical strain gauge length
0,6 up to 0,8 b

Figure A.7 — Measuring set-up for load transfer test

Bibliography

- [1] ENV 1992-1-1, *Eurocode 2: Design of concrete structures — Part 1-1: General rules and rules for buildings*.
- [2] ENV 1992-2, *Eurocode 2: Design of concrete structures — Part 2: Concrete bridges*.
- [3] ETAG 013, *Guideline for European Technical Approval of Post-Tensioning kits for prestressing of structures (Edition February 2002)*.

BSI — British Standards Institution

BSI is the independent national body responsible for preparing British Standards. It presents the UK view on standards in Europe and at the international level. It is incorporated by Royal Charter.

Revisions

British Standards are updated by amendment or revision. Users of British Standards should make sure that they possess the latest amendments or editions.

It is the constant aim of BSI to improve the quality of our products and services. We would be grateful if anyone finding an inaccuracy or ambiguity while using this British Standard would inform the Secretary of the technical committee responsible, the identity of which can be found on the inside front cover.
Tel: +44 (0)20 8996 9000. Fax: +44 (0)20 8996 7400.

BSI offers members an individual updating service called PLUS which ensures that subscribers automatically receive the latest editions of standards.

Buying standards

Orders for all BSI, international and foreign standards publications should be addressed to Customer Services. Tel: +44 (0)20 8996 9001.
Fax: +44 (0)20 8996 7001. Email: orders@bsi-global.com. Standards are also available from the BSI website at <http://www.bsi-global.com>.

In response to orders for international standards, it is BSI policy to supply the BSI implementation of those that have been published as British Standards, unless otherwise requested.

Information on standards

BSI provides a wide range of information on national, European and international standards through its Library and its Technical Help to Exporters Service. Various BSI electronic information services are also available which give details on all its products and services. Contact the Information Centre.
Tel: +44 (0)20 8996 7111. Fax: +44 (0)20 8996 7048. Email: info@bsi-global.com.

Subscribing members of BSI are kept up to date with standards developments and receive substantial discounts on the purchase price of standards. For details of these and other benefits contact Membership Administration.
Tel: +44 (0)20 8996 7002. Fax: +44 (0)20 8996 7001.
Email: membership@bsi-global.com.

Information regarding online access to British Standards via British Standards Online can be found at <http://www.bsi-global.com/bsonline>.

Further information about BSI is available on the BSI website at <http://www.bsi-global.com>.

Copyright

Copyright subsists in all BSI publications. BSI also holds the copyright, in the UK, of the publications of the international standardization bodies. Except as permitted under the Copyright, Designs and Patents Act 1988 no extract may be reproduced, stored in a retrieval system or transmitted in any form or by any means – electronic, photocopying, recording or otherwise – without prior written permission from BSI.

This does not preclude the free use, in the course of implementing the standard, of necessary details such as symbols, and size, type or grade designations. If these details are to be used for any other purpose than implementation then the prior written permission of BSI must be obtained.

Details and advice can be obtained from the Copyright & Licensing Manager.
Tel: +44 (0)20 8996 7070. Fax: +44 (0)20 8996 7553.
Email: copyright@bsi-global.com.