

BS EN 13381-2:2014



BSI Standards Publication

Test methods for determining the contribution to the fire resistance of structural members

Part 2: Vertical protective membranes

bsi.

...making excellence a habit.™

National foreword

This British Standard is the UK implementation of EN 13381-2:2014. It supersedes DD ENV 13381-2:2002 which is withdrawn.

The UK participation in its preparation was entrusted to Technical Committee FSH/22/-/7, Non loadbearing separating elements.

A list of organizations represented on this committee can be obtained on request to its secretary.

This publication does not purport to include all the necessary provisions of a contract. Users are responsible for its correct application.

© The British Standards Institution 2014. Published by BSI Standards Limited 2014

ISBN 978 0 580 78056 1

ICS 13.220.50; 13.220.99

Compliance with a British Standard cannot confer immunity from legal obligations.

This British Standard was published under the authority of the Standards Policy and Strategy Committee on 30 September 2014.

Amendments issued since publication

Date	Text affected
------	---------------

EUROPEAN STANDARD

EN 13381-2

NORME EUROPÉENNE

EUROPÄISCHE NORM

September 2014

ICS 13.220.50; 13.220.99

Supersedes ENV 13381-2:2002

English Version

Test methods for determining the contribution to the fire resistance of structural members - Part 2: Vertical protective membranes

Méthodes d'essai pour déterminer la contribution à la résistance au feu des éléments de construction - Partie 2: Membranes de protection verticales

Prüfverfahren zur Bestimmung des Beitrages zum Feuerwiderstand von tragenden Bauteilen - Teil 2: Vertikal angeordnete Brandschutzbekleidungen

This European Standard was approved by CEN on 25 July 2014.

CEN members are bound to comply with the CEN/CENELEC Internal Regulations which stipulate the conditions for giving this European Standard the status of a national standard without any alteration. Up-to-date lists and bibliographical references concerning such national standards may be obtained on application to the CEN-CENELEC Management Centre or to any CEN member.

This European Standard exists in three official versions (English, French, German). A version in any other language made by translation under the responsibility of a CEN member into its own language and notified to the CEN-CENELEC Management Centre has the same status as the official versions.

CEN members are the national standards bodies of Austria, Belgium, Bulgaria, Croatia, Cyprus, Czech Republic, Denmark, Estonia, Finland, Former Yugoslav Republic of Macedonia, France, Germany, Greece, Hungary, Iceland, Ireland, Italy, Latvia, Lithuania, Luxembourg, Malta, Netherlands, Norway, Poland, Portugal, Romania, Slovakia, Slovenia, Spain, Sweden, Switzerland, Turkey and United Kingdom.



EUROPEAN COMMITTEE FOR STANDARDIZATION
COMITÉ EUROPÉEN DE NORMALISATION
EUROPÄISCHES KOMITEE FÜR NORMUNG

CEN-CENELEC Management Centre: Avenue Marnix 17, B-1000 Brussels

Contents

Page

Foreword.....	4
1 Scope	6
2 Normative references	6
3 Terms and definitions, symbols and units.....	7
3.1 Terms and definitions	7
3.2 Symbols and units	8
4 Test equipment	8
4.1 General.....	8
4.2 Furnace	9
4.3 Test frame	9
4.4 Supporting construction	9
4.5 Furnace closure	9
5 Test conditions	10
5.1 General.....	10
5.2 Support and restraint	10
5.2.1 Standard conditions	10
5.2.2 Other support and restraint conditions.....	10
6 Test specimens	10
6.1 General.....	10
6.2 Number of tests.....	11
6.3 Size of test specimen	11
6.4 Structural building members	11
6.4.1 Standard vertical structural building members	11
6.4.2 Practical vertical structural members.....	12
6.5 Properties of test materials	13
6.6 Verification of the test specimen	13
6.7 Optional and additional plate thermometers within the cavity	13
7 Installation of the test construction	14
8 Conditioning.....	14
9 Application of instrumentation.....	14
9.1 General.....	14
9.2 Instrumentation for measurement of furnace temperature	14
9.3 Instrumentation for measurement of specimen temperature	15
9.3.1 General.....	15
9.3.2 Instrumentation for measuring cavity temperature	15
9.3.3 Instrumentation for measuring surface temperatures	15
9.3.4 Optional and supplementary instrumentation for measuring temperature	16
9.4 Instrumentation for measurement of pressure.....	16
10 Test procedure	16
10.1 General.....	16
10.2 Furnace temperature and pressure	16
10.3 Temperatures of the test specimen	17
10.4 Observations	17
10.5 Termination of the test	17

11	Test results	17
11.1	Acceptability of test results.....	17
11.2	Presentation of test results	17
12	Test report.....	18
13	Assessment	18
13.1	General	18
13.2	Assessment of loadbearing capacity	19
13.2.1	General	19
13.2.2	Characteristic temperature curve: cavity temperatures.....	19
13.2.3	Characteristic temperature curve: surface temperatures (steel or concrete or composite columns).....	19
13.2.4	Application of method of limiting temperatures	19
13.3	Assessment of integrity and insulation	20
13.4	Assessment of data for calculation purposes.....	20
14	Report of the assessment.....	20
15	Limits of applicability of the results of the assessment	21
15.1	Type of vertical structural building member	21
15.2	Type of steel column.....	23
15.3	Size of concrete column	23
15.4	Size of concrete filled hollow steel composite column.....	23
15.5	Type of concrete.....	23
15.6	Timber column.....	24
15.7	Depth of the cavity	24
15.8	Type of closure opposite to the vertical protective membrane.....	24
15.9	Properties of the vertical protective membrane.....	24
15.10	Size of the vertical protective membrane	24
15.11	Size of panels within the vertical protective membrane	24
15.12	Fixtures and fittings	24
15.13	Applicability of results from test columns to beams or combined column /beam structural building members.....	25
Annex A	(normative) Measurement of properties of vertical protective membranes and components	30
A.1	General	30
A.2	Thickness of vertical protective membrane and components thereof	30
A.3	Density of vertical protective membranes and components thereof.....	31
A.3.1	General	31
A.4	Moisture content of vertical protective membrane and components thereof.....	32
Annex B	(normative) Test method to the smouldering fire (slow heating curve).....	33
B.1	Introduction.....	33
B.2	Test equipment.....	33
B.3	Test specimens.....	33
B.4	Termination of test	33
B.5	Evaluation of the results.....	34
Bibliography	35

Foreword

This document (EN 13381-2:2014) has been prepared by Technical Committee CEN/TC 127 “Fire safety in buildings”, the secretariat of which is held by BSI.

This European Standard shall be given the status of a national standard, either by publication of an identical text or by endorsement, at the latest by March 2015 and conflicting national standards shall be withdrawn at the latest by March 2015.

Attention is drawn to the possibility that some of the elements of this document may be the subject of patent rights. CEN [and/or CENELEC] shall not be held responsible for identifying any or all such patent rights.

This document supersedes ENV 13381-2:2002.

The main changes with respect to the previous edition are listed below:

Clarifications regarding the following items:

- a) preparation of the test specimen;
- b) instrumentation of the test specimen (no more steel plate within the cavity);
- c) limits of applicability.

This document has been prepared under a mandate given to CEN by the European Commission and the European Free Trade Association.

This European Standard is one of a series of standards for evaluating the contribution to the fire resistance of structural members by applied fire protection materials. Other parts of the standard are:

- *Part 1: Horizontal protective membranes,*
- *Part 3: Applied protection to concrete members,*
- *Part 4: Applied protection to steel members,*
- *Part 5: Applied protection to concrete / profiled sheet steel composite members,*
- *Part 6: Applied protection to concrete filled hollow steel columns,*
- *Part 7: Applied protection to timber members,*
- *Part 8: Applied reactive protection to steel members.*

The fire protection capacity of the vertical protective membrane can be nullified by the presence of combustible materials in the cavity behind the membrane. The applicability of the results of the assessment is limited according to the quantity and position of such combustible materials within that cavity. The amount of combustible material permissible in the cavity should be given in national regulations.

Caution

The attention of all persons concerned with managing and carrying out this fire resistance test, is drawn to the fact that fire testing can be hazardous and that there is a possibility that toxic and / or harmful smoke and gases can be evolved during the test. Mechanical and operational hazards can also arise during the construction of test elements or structures, their testing and the disposal of test residues.

An assessment of all potential hazards and risks to health shall be made and safety precautions shall be identified and provided. Written safety instructions shall be issued. Appropriate training shall be given to relevant personnel. Laboratory personnel shall ensure that they follow written safety instructions at all times.

The specific health and safety instructions contained within this standard shall be followed.

When testing concrete filled hollow steel composite columns steam release holes shall be provided for the release of steam from the column, during the test, as specified in EN 13381-6.

According to the CEN-CENELEC Internal Regulations, the national standards organizations of the following countries are bound to implement this European Standard: Austria, Belgium, Bulgaria, Croatia, Cyprus, Czech Republic, Denmark, Estonia, Finland, Former Yugoslav Republic of Macedonia, France, Germany, Greece, Hungary, Iceland, Ireland, Italy, Latvia, Lithuania, Luxembourg, Malta, Netherlands, Norway, Poland, Portugal, Romania, Slovakia, Slovenia, Spain, Sweden, Switzerland, Turkey and the United Kingdom.

1 Scope

This European Standard specifies a test method for determining the ability of a vertical protective membrane, when used as a fire resistant barrier, to contribute to the fire resistance (loadbearing capacity R) of loadbearing vertical structural building members fabricated from steel, concrete, steel/concrete composites or timber. The method described is applicable to any type of vertical protective membrane, which can be associated with a separate bracing membrane.

The vertical protective membrane can be either separated from or attached to the structural building member and is self-supporting. This test method is applicable to vertical protective membranes where there is a gap and a cavity between the vertical protective membrane and the structural building member, otherwise alternative test methods prEN 13381-3, EN 13381-4, EN 13381-6 or prEN 13381-7 should be used as appropriate.

This test method and assessment is not applicable to the following:

- a) all situations where the cavity is to be used as a service or ventilation shaft;
- b) all situations where the vertical protective membrane acts as a bracing membrane.

This European Standard contains the fire test which specifies the tests which shall be carried out whereby the vertical protective membrane together with the structural member to be protected is exposed to the specified fire. The fire exposure, to the standard temperature/time curve given in EN 1363-1, is applied to the side which would be exposed in practice.

The test method makes provision, through specified optional additional procedures, for the collection of data which can be used as direct input to the calculation of fire resistance according to the processes given in EN 1992-1-2, EN 1993-1-2, EN 1994-1-2 and EN 1995-1-2.

This European Standard also contains the assessment which provides information relative to the analysis of the test data and gives guidance for the interpretation of the results of the fire test, in terms of loadbearing capacity criteria of the protected vertical structural member.

The results of the fire test and the assessment can be applied, with certain defined provisions, to vertical structural building members which can be beams, columns or a combination of both and / or which could form part of a separating element or partition.

The limits of applicability of the results of the assessment arising from the fire test are defined, together with permitted direct application of the results to different structures, membranes and fittings.

In special circumstances, where specified in national building regulations, there can be a need to subject the protection material to a smouldering curve. The test for this and the special circumstances for its use are detailed in Annex B.

Tests should be carried out without additional combustible materials in the cavity.

2 Normative references

The following documents, in whole or in part, are normatively referenced in this document and are indispensable for its application. For dated references, only the edition cited applies. For undated references, the latest edition of the referenced document (including any amendments) applies.

EN 206, *Concrete - Specification, performance, production and conformity*

- EN 1363-1, *Fire resistance tests - Part 1: General Requirements*
- EN 1363-2, *Fire resistance tests - Part 2: Alternative and additional procedures*
- EN 1364-1, *Fire resistance tests for non-loadbearing elements - Part 1: Walls*
- EN 1365-1, *Fire resistance tests for loadbearing elements - Part 1: Walls*
- EN 1992-1-2, *Eurocode 2: Design of concrete structures - Part 1-2: General rules - Structural fire design*
- EN 1993-1-2, *Eurocode 3: Design of steel structures - Part 1-2: General rules - Structural fire design*
- EN 1994-1-2, *Eurocode 4 - Design of composite steel and concrete structures - Part 1-2: General rules - Structural fire design*
- EN 1995-1-2:2004, *Eurocode 5: Design of timber structures - Part 1-2: General - Structural fire design*
- EN 10025-1, *Hot rolled products of structural steels – Part 1: General technical delivery conditions*
- EN 10080, *Steel for the reinforcement of concrete - Weldable reinforcing steel - General*
- EN 10210-1, *Hot finished structural hollow sections of non-alloy and fine grain steels - Part 1: Technical delivery conditions*
- prEN 13381-3, *Test methods for determining the contribution to the fire resistance of structural members - Part 3: Applied protection to concrete members*
- EN 13381-4, *Test methods for determining the contribution to the fire resistance of structural members - Part 4: Applied passive protection to steel members*
- EN 13381-6, *Test methods for determining the contribution to the fire resistance of structural members - Part 6: Applied protection to concrete filled hollow steel columns*
- prEN 13381-7, *Test methods for determining the contribution to the fire resistance of structural members - Part 7: Applied protection to timber members*
- EN ISO 13943, *Fire safety - Vocabulary (ISO 13943)*
- ISO 8421-2, *Fire protection - Vocabulary - Part 2: Structural fire protection*

3 Terms and definitions, symbols and units

3.1 Terms and definitions

For the purposes of this document, the terms and definitions given in EN 1363-1, EN ISO 13943 and ISO 8421-2 and the following apply.

3.1.1

vertical structural building member

vertical loadbearing structural element of building construction, which may be a column, a beam or a combination of both, and / or which might form part of a separating element or partition and which is fabricated from either concrete, steel, steel/concrete composite or timber

3.1.2

vertical protective membrane

material or construction that may comprise multiple layers of materials, which is installed in front of a vertical structural building member and which is intended to give additional fire resistance to that member

3.1.3

structural building member test column

test column, representing the loadbearing structural building member to be protected in practice, in front of which the vertical protective membrane test specimen is installed for the purposes of the test

3.1.4

vertical protective membrane test specimen

full vertical protective membrane assembly submitted for test, including typical fixing equipment and methods and typical features such as insulating materials, light fittings, ventilation ducts

3.1.5

furnace closure

fire resistant vertical construction designed to close the furnace and with the vertical protective membrane create a cavity within which the test column is placed

3.1.6

separating gap

distance between the rear face of the vertical protective membrane and the closest surface of the structural building member test column

3.1.7

cavity

whole void between the rear face of the vertical protective membrane and the furnace closure

3.1.8

fire protection

protection afforded to the structural building member by the vertical protective membrane such that the temperature on the surface of the test column and within the cavity is limited throughout the period of exposure to fire

3.1.9

characteristic temperature

the average of the mean temperature and the maximum individual temperature $[(\text{mean} + \text{maximum})/2]$ for a group of thermocouples

3.2 Symbols and units

Symbol	Unit	Designation
Am/V	m ⁻¹	Section factor of unprotected steel column (see EN 13381-4).

4 Test equipment

4.1 General

The furnace and test equipment shall be as specified in EN 1363-1.

4.2 Furnace

The furnace shall be at least 3 x 3 m (height x width) and designed to permit the dimensions of the test specimen to be exposed to heating to be as specified in 6.3 and its installation to be as described in Clause 7.

4.3 Test frame

The vertical protective membrane test specimen, the test column and the furnace closure shall be mounted in a test frame which shall be designed such that it possesses sufficient stiffness appropriate to the test construction in accordance with EN 1363-1.

An example of suitable frame for this purpose shall have head and side members constructed from steel section protected with refractory concrete having a nominal density of at least 2 000 kg/m³ or can be a frame made of reinforced concrete having a nominal density of at least 2 000 kg/m³.

The dimensions of the test frame shall be such that the furnace closure, the test column and the vertical protective membrane test specimen, together with any supporting construction, may be installed within it (see Figure 1) and permit the size of the test construction exposed to heating to be as specified in 6.3.

4.4 Supporting construction

If the size of the vertical protective membrane test specimen is smaller than the test frame of the laboratory then the test frame opening shall be reduced in size by building a supporting construction in the test frame.

If the vertical protective membrane is required in practice to be used together with any supporting construction then the test construction shall include that supporting construction, otherwise, a standard construction made of aerated concrete slabs or blocks of density (650 ± 200) kg/m³ and suitable thickness to accommodate the furnace closure, the columns and the vertical protective membrane, bonded with sand / cement mortar or other fire resistant material shall be used.

4.5 Furnace closure

The fire resistant furnace closure is designed to close the furnace and to create, together with the vertical protective membrane test specimen, a cavity to contain the test column.

The standard furnace closure shall comprise a wall built within the test frame comprising aerated concrete slabs or blocks of density (650 ± 200) kg/m³ and thickness (100 ± 10) mm, bonded with sand/cement mortar or other appropriate fire resistant material.

Where the vertical protective membrane is to be used on both sides of the structural building member, then the furnace closure shall comprise the same vertical protective membrane system. This type of furnace closure shall be sealed into the test frame by the same method as would be used for the vertical protective membrane in use. The applicability of the result shall be restricted in this case (see 15.8).

At the request of the sponsor, insulation material of lower insulation performance than that normally required, representing a high heat loss external or internal wall or open cavity situation (remote from the fire exposure side) may be used. The choice of such materials shall be made by the sponsor. The laboratory shall ensure that they are inserted into the test frame and all joints sealed, both within the closure and around its edges, such that leakage of gases from the cavity cannot occur. The applicability of the result of such non-standard furnace closure shall be restricted in this case (see 15.8).

If the vertical protective membrane is to be used in a situation where it forms a ventilated cavity in which the building member it protects is situated, then the test cavity shall be ventilated in a manner representative of practice. The applicability of the result shall be restricted in this case (see 15.8).

5 Test conditions

5.1 General

A loadbearing vertical structural building member represented by an unloaded test column is protected against fire by a vertical protective membrane and subjected to the fire test defined herein. The temperature within the cavity and the surface temperature of the test column are measured throughout the test.

It is recommended that the test is continued until the mean temperature recorded by all thermocouples within the cavity, reaches the appropriate limiting temperature for the test columns used or until any individual temperature recorded within the cavity, rises to 750 °C for steel, concrete or concrete filled hollow steel columns and 500 °C for timber columns.

The procedures given in EN 1363-1 shall be followed in the performance of this test method unless otherwise stated in this European Standard.

5.2 Support and restraint

5.2.1 Standard conditions

Where the vertical protective membrane test specimen in practice is not larger than the furnace opening, the edges of the specimen shall be installed and restrained as in practice.

Where the vertical protective membrane test specimen in practice is larger than the furnace opening then it shall be installed as in practice, but with one vertical edge unrestrained and having freedom of movement, the remaining edges being restrained as in practice.

Any unrestrained edges shall be sealed with fire resistant material which shall accommodate movement of those edges and yet not restrict that movement, or allow furnace gases to leak into the cavity. The distance between the exposed face of the vertical protective membrane and the forward edge of the test frame shall be sufficient to accommodate any bowing of the membrane, without allowing furnace gases to leak into the cavity. The sponsor shall define expected bowing, where possible.

5.2.2 Other support and restraint conditions

Support and restraint conditions differing from the standard conditions specified in 5.2.1 shall be described in the test report and the validity of the results restricted to that tested.

6 Test specimens

6.1 General

The structural building member to be used in the test shall be as given in 6.3 and be chosen from those standard members described in 6.4.1 and be representative of that to be used in practice. Alternatively, an actual practical structural vertical building member may be used according to 6.4.2.

Vertical protective membranes would typically be board or panel type partitions or membranes, comprising timber, plaster, mineral wool or similar materials. They shall be installed in front of the test column by the procedures given in the installation manual or other written instructions provided by the sponsor. The means of connection and use of insulation between the membrane and the test frame shall be defined by the sponsor.

Where the vertical protective membrane is expected to include joints or a gap (or gaps) for design purposes or in practice these shall be included within the vertical protective membrane test specimen and be included in a manner representative of practice, in both vertical and horizontal directions.

All fixtures and fittings expected to be installed shall be included in the vertical protective membrane test specimen and the spacing of these shall be representative of practice. Such fixtures and fittings shall not be installed within the test specimen at a distance of less than 500 mm from any of its edges.

6.2 Number of tests

Normally for a vertical protective membrane designed for one sided protection of a vertical structural building member only one test shall be carried out.

Where a vertical protective membrane is manufactured with elements or components of variable size or may be installed by different procedures, then a unique test shall be carried out on elements or components at maximum and minimum size and with every expected installation procedure for which the sponsor requires approval.

Where a vertical protective membrane is designed to protect two or more sides of a structural building member and the vertical protective membrane is the same on all sides then one test only shall be required. In this test the furnace closure shall be the vertical protective membrane itself as given in 4.5.

Where a vertical protective membrane is designed to protect two or more sides of a structural building member and the vertical protective membrane is not the same on all sides then unique tests shall be required for each type of membrane, with each in turn presented to the furnace. Each test result shall be treated separately for field of direct application purposes.

6.3 Size of test specimen

The whole area of the test construction shall be exposed to the furnace conditions.

If the vertical protective membrane in practice is less than 3 000 mm × 3 000 mm then the complete test specimen shall be brought up to this size by filling the bottom part of the frame with aerated concrete.

When the actual size is larger than can be accommodated in the furnace then a reduced size test specimen, of size not less than 3 000 mm × 3 000 mm, including representative joints in both horizontal and vertical directions, shall be used.

6.4 Structural building members

6.4.1 Standard vertical structural building members

Each test construction shall include two test columns, representing loadbearing vertical structural building members.

The test column or columns, chosen by the sponsor, may be steel, concrete, concrete filled hollow steel or timber according to the sponsor's wishes and the desired applicability of the test result (see Table 2).

Mixing different types of material for the columns in the same test is not allowed.

Test columns shall have a height of $(3\ 000 \pm 50)$ mm and be securely fixed vertically in the test frame at the top and bottom, with allowance for expansion.

Two columns shall be placed symmetrically at $\frac{1}{3}$ and $\frac{2}{3}$ exposed width with a clear space of (20 ± 10) mm between the test column and the furnace closure.

The separating gap between the test columns and the vertical protective membrane shall be defined by the sponsor, be normally that to be used in practice but, however, be no less than 5 mm size.

The following structural building members upon which the test columns are based are considered to be standard for this test method.

a) Steel test columns

The standard steel test column shall comprise a hot rolled H profile steel column of section type HEB 140 with section depth of typically (140 ± 5) mm. The grade of steel used shall be any structural grade (S designation) to EN 10025-1. Engineering grades (E designation) shall not be used.

Provision shall be made to minimise heat transfer from the ends of the steel column. The ends shall be protected with insulation board or similar material.

Other larger section factor can be used according to the required application field (see 15.2) for steel.

b) Concrete test columns

The cross section of the standard concrete test column shall be of (150 ± 5) mm \times (200 ± 5) mm. The column shall be made from normal concrete of density $(2\,300 \pm 150)$ kg/m³. The concrete shall be of type C20/25 or C25/30 prepared from silicious aggregates, of maximum dimension of 20 mm and portland cement according to EN 206. It shall contain nominal 12 mm diameter reinforcing bars which shall be ribbed and of grade B 500 or comparable grade to EN 10080. They shall be covered by 20 mm to 25 mm of concrete. Permitted tolerances on size of reinforcing bars are given in EN 10080.

Other concrete grades within the strength range C20/25 to C50/60 and other non-silicious aggregates may be used, however, the applicability of the result shall be restricted according to prEN 13381-3.

The consistency of the wet concrete shall be of type S3 or F3 determined in accordance with EN 206, to allow for good compaction and production of a smooth surface.

c) Concrete filled hollow steel test columns

The standard concrete filled hollow steel composite test column shall comprise a steel hollow section of size (150 to 160) mm \times (150 to 160) mm or a circular column of (160 to 170) mm diameter. The thickness of the steel shall be the minimum available.

The hollow steel test column shall contain at least two 20 mm diameter holes (one at either end) for steam venting (See Figure 3). The hollow steel test column shall be filled with concrete to the composition specified in 6.4.1.b). The steel used shall be at least of grade S235 or comparable grade as defined in EN 10210-1.

Steel plates of area greater than the cross-sectional area of the test column, by at least 10 mm in every direction and 20 mm approximate thickness shall be welded to both the top and the bottom of the test column, after the column is conditioned and before testing.

d) Timber test columns

The standard timber test column is softwood timber of density (450 ± 75) kg/m³. The cross section shall be (100 ± 5) mm \times (50 ± 5) mm.

6.4.2 Practical vertical structural members

The fire protection given by a vertical protective membrane to any practical vertical structural member (different from those specified in 6.4.1) may be evaluated using the principles given in this test method, although the application of the result is restricted to that tested.

6.5 Properties of test materials

Where appropriate, the actual properties of materials used in the structural building member tested (e.g. concrete strength) shall be determined according to EN 1363-1, using an appropriate product test standard, e.g. concrete strength. Otherwise nominal values may be used, e.g. for steel and wood based materials. The dimensions of the structural building member used shall be measured.

The composition of the vertical protective membrane shall be specified by the sponsor and include, at least, its expected nominal density, moisture content and overall thickness. For confidentiality reasons the sponsor may not wish detailed formulation or composition details to be reported in the test report. Such data shall, however, be provided and maintained in confidence in laboratory files.

The actual thickness, density and moisture content of the components of the vertical protective membrane shall be measured and recorded, just prior to the time of test, on the components themselves or on special test samples taken from the test component. These shall be conditioned as defined in Clause 8.

The procedures appropriate to different types of material are given in Annex A. The thickness of sprayed or coated passive or reactive fire protection materials when used as component parts of vertical protective membranes shall be measured in the proximity of each of the nine positions in the three cross sectional areas defined in 9.3.2 and Figure 2.

The thickness of slab or board type fire protection materials should not deviate by more than 15 % of the mean value over the whole of its surface. The mean value shall be used in the assessment of the results and in the limits of applicability of the assessment. If the board thickness varies by more than 15 % then the maximum thickness recorded shall be used in the assessment.

The thickness of sprayed or coated, passive or reactive type fire protection materials when used as component parts of vertical protective membranes shall be measured according to Annex A. The thickness shall not deviate by more than 20 % of the mean value over the whole of its surface. The mean value shall be used in the assessment of the results and the limits of applicability of the assessment. If it deviates by more than 20 %, the maximum thickness recorded shall be used in the assessment.

The density of the vertical protective membrane shall be measured according to Annex A and recorded. The density shall not deviate by more than 15 % of the mean value. In this case, the mean value shall be used in the assessment of the results and the limits of applicability of the assessment. If it deviates by more than 15 % the maximum density recorded shall be used in the assessment.

6.6 Verification of the test specimen

An examination and verification of the test specimen for conformity to specification shall be carried out as described in EN 1363-1.

The properties of the materials used in the preparation of the test specimen shall be measured using special samples, where necessary, as described in 6.5 using the methods given in Annex A.

The sponsor shall verify materials contained within the test specimen which are applied by spray or coating for compliance to design composition and specification using tests appropriate to the material.

6.7 Optional and additional plate thermometers within the cavity

At the request of the sponsor, where there is a need to obtain test data for use as direct input to the calculation of fire resistance according to the procedures given in EN 1992-1-2, EN 1993-1-2, EN 1994-1-2 and EN 1995-1-2 additional plate thermometers shall be used within the cavity.

Three plate thermometers shall be suspended vertically, in the long direction, within the cavity, each with its centre at $\frac{3}{4}$ furnace height. Each shall be placed symmetrically between the test columns or between a test

column and the furnace wall. They shall be placed halfway between the vertical protective membrane and the furnace closure. They shall be oriented so that side 'A' faces towards the vertical protective membrane.

They shall be suspended from the top of the test frame by 10 mm diameter steel threaded rods or brackets of similar cross sectional area. Thermal breaks shall be incorporated between each plate and its suspension device.

7 Installation of the test construction

The test column(s) shall be mounted vertically in the plane of the test frame and the furnace.

Steel test columns shall be installed with the flanges parallel to the surface of the vertical protective membrane. Non-symmetrical test columns shall be installed with the longer edge parallel to the surface of the vertical protective membrane.

The vertical protective membrane test specimen when tested full size shall be installed in the opening in the test frame in a manner representative of its use in practice.

Where a plinth or supporting construction is to be used to increase the size of the vertical protective membrane test specimen, according to 4.4, then the test specimen shall be fixed to this and to the test frame in a manner representative of its use in practice. The plinth or supporting construction shall have been installed and attached within the test frame in a suitable manner.

The furnace closure shall be installed in the test frame according to 4.5.

The order in which the columns, furnace closure, supporting construction and protective membrane are installed within the test frame shall be appropriate to practice.

8 Conditioning

The test construction and all its component materials plus test samples taken for the determination of material properties (specified in 6.5) shall be conditioned according to EN 1363-1.

Material properties (specified in 6.5) shall be determined according to Annex A and EN 1363-1.

The recommended conditioning time for concrete and concrete filled hollow steel columns is 90 days.

9 Application of instrumentation

9.1 General

The instrumentation for the measurement of temperature and furnace pressure shall comply with the requirements of EN 1363-1.

9.2 Instrumentation for measurement of furnace temperature

Plate thermometers of the type specified in EN 1363-1 shall be provided to measure the temperature of the furnace. They shall be uniformly distributed, with at least one centrally placed within every 1,5 m² of the exposed test specimen surface area, the exposed area being the nominal area measured in the plane of the specimen (see Figure 2).

The plate thermometers shall be oriented so that side 'A' faces the floor of the furnace. For test specimens with less than 6 m² exposed area, a minimum of four plate thermometers shall be used.

9.3 Instrumentation for measurement of specimen temperature

9.3.1 General

Instrumentation shall be provided for the measurement and recording of cavity temperature, surface temperature of the test specimen and the temperature at other optional locations.

9.3.2 Instrumentation for measuring cavity temperature

A total of nine thermocouples shall be used for measuring cavity temperatures, in sets of three, in each of three cross sectional areas, ($T_1 - T_9$ in Figure 2). Each thermocouple in a set is separated horizontally from the next by (750 ± 100) mm.

- Area 1: central section, located halfway up the cavity;
- Area 2: (1000 ± 100) mm above the central section;
- Area 3: (1000 ± 100) mm below the central section or halfway between the central section and the bottom of the membrane when the height is lower than 3 m.

These nine thermocouples shall be positioned half way between the vertical protective membrane and the furnace closure. They shall be of the double glass fibre insulated type specified in EN 1363-1.

9.3.3 Instrumentation for measuring surface temperatures

a) Standard building members

When standard building members of the type specified in 6.4.1 are used, three thermocouples per test column shall be provided to measure surface temperatures of steel, concrete and concrete filled hollow steel column test columns only.

These thermocouples shall be located on surface towards the fire or flange of each column, (thermocouples a1 - a6 given in Figure 2), one in each of the three cross sectional areas for each column:

- Area 1: central section, located halfway up the cavity;
- Area 2: $(1\ 000 \pm 100)$ mm above the central section;
- Area 3: $(1\ 000 \pm 100)$ mm below the central section or halfway between the central section and the bottom of the building member when the height is lower than 3 m.

Thermocouples for measuring surface temperature of the test columns shall be of the double glass fibre insulated bare wire type specified, positioned and fixed according to EN 1363-1, without any insulating pad.

b) Non-standard test construction

When a non-standard test construction is tested, e.g. an actual practical furnace closure (see 4.5) instead of the standard furnace closure, then in addition to the thermocouples specified in 9.3.3 a), five thermocouples located on the rear, outside, surface of the furnace closure (thermocouples c1 to c5 given in Figure 2) shall be used.

These shall be of the copper disc type specified in EN 1363-1. They shall be positioned and fixed as specified in EN 1363-1.

9.3.4 Optional and supplementary instrumentation for measuring temperature

- a) To generate data for use in calculation of fire resistance

Where the sponsor requires temperature data for use as direct input to the calculation of fire resistance according to the procedures given in EN 1992-1-2, EN 1993-1-2, EN 1994-1-2 and EN 1995-1-2 the following shall be used within the cavity:

- Three plate thermocouples (PT1 to PT3), as specified in 6.7.

- b) To generate other optional data

Other thermocouples may be used to generate optional data at the request of the sponsor. These shall all be of the appropriate type and fixing specified in EN 1363-1. These include:

- Five thermocouples located at the non-exposed side of the furnace closure when standard building members are used (thermocouples c1 to c5 given in Figure 2).
- Six thermocouples, three per test column, to measure temperatures of the rear surface or flange of steel, concrete and concrete filled hollow steel column test columns only. These thermocouples (a7 - a12 given in Figure 2), shall be located one in each of the same three cross sectional areas on the column as those thermocouples located on the surface towards the furnace or flange.
- Five thermocouples located on the forward surface of the furnace closure within the cavity (thermocouples b1 to b5 given in Figure 2).
- Up to three thermocouples located on the rear face of the vertical protective membrane not exposed to fire (thermocouples d1 to d3 given in Figure 2). These shall be located:
 - one thermocouple in the centre of the membrane. If the membrane is made up of panels then this thermocouple shall be placed at the centre of a panel;
 - one thermocouple at a vertical membrane joint if included;
 - one thermocouple at a horizontal membrane joint if included.

9.4 Instrumentation for measurement of pressure

Instrumentation for measuring pressure within the furnace shall be provided, located and used as specified in EN 1363-1.

10 Test procedure

10.1 General

Carry out checks for thermocouple consistency and establish data points for temperature as specified in EN 1363-1 before commencement of the test and the procedures given in 10.2 to 10.5.

10.2 Furnace temperature and pressure

Measure and record the furnace temperature using the thermocouples defined in 9.2 and the furnace pressure in accordance with the procedures and frequency specified in EN 1363-1.

Control the furnace temperature according to the data received from the furnace temperature measurement thermocouples to the criteria of EN 1363-1.

Control the furnace pressure to the criteria of EN 1363-1.

10.3 Temperatures of the test specimen

Measure and record the temperature within the cavity and upon the surface of the test columns using the thermocouples specified in 9.3.2 and 9.3.3, at intervals not exceeding 1 min. Where any of the supplementary and optional thermocouples specified in 9.3.4 are used measure and record the temperatures from these at intervals not exceeding 1 min.

10.4 Observations

Wherever practical, monitor the general behaviour of the test specimen, especially the vertical protective membrane, throughout the test and record the occurrence of cracking, fissuring, deterioration, delamination or similar behaviour as described in EN 1363-1.

10.5 Termination of the test

Terminate the test when the mean temperature recorded by all nine thermocouples within the cavity, specified in 9.3.2, reaches the appropriate limiting temperature for the test columns used (specified in 13.2.4) or until any individual temperature recorded within the cavity rises to 750 °C for steel, concrete or concrete filled hollow steel columns and 500 °C for timber columns or when one or more of the reasons for termination, specified in EN 1363-1, occurs.

11 Test results

11.1 Acceptability of test results

It is possible that within any test apparently erroneous results may occur through failure of thermocouples, abnormal behaviour of the test specimen, etc. The criteria for acceptability of temperature data given in EN 1363-1 shall be observed.

11.2 Presentation of test results

The following shall be reported within the test report:

- a) the results of measured dimensions and actual material properties, especially the thickness, density and moisture contents of the test specimen and its components, together with those values to be used in the assessment, as defined in 6.5;
- b) the individual results of all furnace temperature measurements and the mean of all individual furnace temperature measurements, taken as specified in EN 1363-1, graphically presented and compared with the specified requirements and tolerances given in EN 1363-1;

The individual results of all furnace pressure measurements and the mean of all individual furnace pressure measurements, taken as specified in EN 1363-1, graphically presented and compared with the specified requirements and tolerances given in EN 1363-1;

- c) the individual results and the mean of all individual results of all the cavity temperature measurement thermocouples specified in 9.3.2, taken as specified in 10.3, all graphically presented. Evidence of compliance with the validity criteria of 11.1;
- d) the individual results and the mean of all individual results of all the surface temperature measurement thermocouples specified in 9.3.3, taken as specified in 10.3, all graphically presented. Evidence of compliance with the validity criteria of 11.1;

- e) the individual results and the mean of all individual results of all optional and supplementary temperature measurement thermocouples specified in 9.3.4, taken as specified in 10.3, all graphically presented. Evidence of compliance with the validity criteria of 11.1.

These results (b) to (e) may be presented as a selection of the measured data sufficient to give a history of the performance of the test specimen according to EN 1363-1.

These results may also be prepared and printed in tabular form and / or presented upon electronic storage. In the latter case this shall be prepared in an appropriate, secure "read only" format to prevent alteration. The only legally genuine data shall be those data maintained in the laboratory files;

- f) the results of observations made and the times at which they occur shall be reported.

12 Test report

The test report shall include the following statement:

"This report provides the constructional details, the test conditions and the results obtained when a specific vertical protective membrane was tested whilst protecting a specific type of test construction following the procedures of test method prEN 13381-2. Any deviation with respect to size, constructional details, edge combinations or fixtures and fittings of the vertical protective membrane from that tested may invalidate the test result."

In addition to the items required by EN 1363-1, the following shall also be included in the test report:

- a) the generic description and fixing details of the vertical protective membrane;
- b) full details of the test specimens including assembly and preparation details including surface preparation especially the depth of the cavity used;
- c) description of the fabrication of the test construction. Description of the conditioning of the test construction and its installation onto the test furnace;
- d) the results of the measurements obtained using the measurement devices in 11.2 a) to f) during the tests presented in graphical format (and any other optional format), as required in 11.2;
- e) if possible a description of significant behaviour of the test specimen observed during the test period, including observations of the time(s) and magnitude of any deterioration or detachment of the vertical protective membrane;
- f) the reason, on the basis of 10.5 of this test method, for the termination of the test and the time elapsed when the test was terminated; especially the depth of the cavity used.

13 Assessment

13.1 General

The assessment details how the contribution of the vertical protective membrane to the fire protection of the structural member is established using temperatures measured within the cavity, upon the surface of the test column and when a practical non-standard vertical structural building member is tested upon the unexposed surface of the furnace closure.

13.2 Assessment of loadbearing capacity

13.2.1 General

For the purposes of this test method, assessment of loadbearing capacity is made by determination from the characteristic temperature curves obtained under 13.2.2 and 13.2.3, the time elapsed to the last completed minute, from the commencement of the test, to the time when specified limiting cavity and surface temperatures, each appropriate to the type of material contained within the structural building member tested, are reached.

13.2.2 Characteristic temperature curve: cavity temperatures

From the temperature data collected and reported in 11.2 the following shall be identified:

- the graph of the mean of all nine individual cavity temperatures;
- the graph of the individual thermocouples giving rise to the highest individual cavity temperature, for all time increments.

The mean of the mean temperature from the nine thermocouples and the maximum individual temperature $[(\text{mean} + \text{maximum})/2]$ shall be calculated and similarly presented, as defined in 11.2. This curve shall be used as characteristic curve for cavity temperature and used in the assessment.

13.2.3 Characteristic temperature curve: surface temperatures (steel or concrete or composite columns)

From the temperature data collected and reported in 11.2 the following shall be identified:

- the graph of the mean of all six individual surface temperatures;
- the graph of the individual thermocouples giving rise to the highest individual surface temperature, for all time increments.

The mean of the mean temperature from the six thermocouples and the maximum individual temperature $[(\text{mean} + \text{maximum})/2]$ shall be calculated and similarly presented, as defined in 11.2, for all time increments. This curve shall be used as characteristic curve for surface temperature and used in the assessment.

13.2.4 Application of method of limiting temperatures

Limiting temperatures are the temperature (defined for both cavity and surface) at which the specific material of construction used within the structural building member will be unable to continue to support its load.

Limiting temperatures for each specific type of material of construction, from which loadbearing capacity is obtained from measurement of cavity temperature are:

- 600 °C vertical members comprising concrete (including that with reinforcing bars);
- 530 °C vertical members comprising steel and vertical members comprising concrete filled hollow steel columns with reinforcing bars;
- 400 °C vertical members comprising concrete filled hollow steel columns without reinforcing bars;
- 370 °C cold formed steel building members;
- 300 °C vertical members comprising timber.

The limiting temperature given for timber members does not permit and takes no account of charring of that timber, contrary to 3-1(8) of EN 1995-1-2:2004. For assessment of charring behaviour the test procedure of prEN 13381-7 shall be followed.

Specific limiting temperatures for each specific type of material of construction, from which loadbearing capacity is obtained from measurement of surface temperature are:

- 550 °C vertical members comprising concrete (including that with reinforcing bars);
- 510 °C vertical members comprising steel and vertical members comprising concrete filled hollow steel columns with reinforcing bars;
- 350 °C vertical members comprising concrete filled hollow steel columns without reinforcing bars;
- 350 °C cold formed steel building members (temperature measured on the steel element).

If the limiting value of temperature is not reached before the test is terminated then the load bearing capacity as defined in this Clause 13 shall be the test duration.

13.3 Assessment of integrity and insulation

This is assessed only when a non-standard furnace closure is tested according to 4.5.

Then thermocouples location and the assessment of integrity and insulation shall be performed in accordance with EN 1365-1.

13.4 Assessment of data for calculation purposes

From the temperature data collected and reported in 11.2 the following shall be identified:

- the graph of the mean of all three individual plate thermometers located in the cavity (plate thermometers PT1 to PT3 given in Figure 2);
- the graph of the individual plate thermometer located in the cavity (plate thermometers PT1 to PT3 given in Figure 2) giving rise to the highest individual temperature.

The assessment and use of these temperature data measured by plate thermometers, to give heat transfer coefficients etc. required to calculate fire resistance according to EN 1992-1-2, EN 1993-1-2, EN 1994-1-2 and EN 1995-1-2 is not considered herein. Users shall consult the relevant EN "Eurocode" Standard.

14 Report of the assessment

The report of the assessment shall include the following:

- a) the name/address of the body providing the assessment and the date it was carried out. Reference to the name/address of the test laboratory, the unique test reference number and report number(s);
- b) the name(s) and address(es) of the sponsor(s). The name of the manufacturer of the product or products and the manufacturer or manufacturers of the construction;
- c) the generic description of the product or products, particularly the vertical protective membrane and any component parts (where known). If unknown this shall be stated;
- d) full details of the test construction with drawings, including dimensions of components, photographs, where appropriate, and if available the installation manual or written instructions provided by the sponsor.

The details of the assembly of the test specimen, especially the depth of the cavity used. Details of its conditioning;

- e) reason for the omission of any test data;
- f) general description of the test specimens forming the basis of the assessment including the dimensions of the test specimens, the composition and measured properties of the components required to be determined from 6.5 and their method of determination;
- g) the results of the loadbearing capacity, determined from the characteristic temperature curves specified in 13.2, being the time elapsed to the last completed minute, from the commencement of the test, to the time when either a specified cavity or surface temperature, appropriate to each type of material of construction, is reached, whichever is earliest. The results of the loadbearing capacity shall be presented according to Table 3;
- h) The report shall also include a statement regarding the limits of direct application of the assessment procedure in accordance with Clause 15;
- i) any specific temperature data obtained from the use of plate thermometers within the cavity, as specified in 13.4;
- j) any specific insulation value of a non-standard test structure determined from the temperature reference curves obtained as specified in 13.3;

Table 1 — Results of loadbearing capacity

For application to the following construction materials	Limiting cavity temperature (°C)	Loadbearing capacity from elapsed time (min)
Concrete	600	
Steel	530	
Hollow steel concrete	400	
cold formed steel building members	370	
timber	300	
For application to the following construction materials	Limiting surface temperature (°C)	Loadbearing capacity from elapsed time (min)
Steel	510	
steel concrete composites	350	
cold formed steel members	350	

15 Limits of applicability of the results of the assessment

15.1 Type of vertical structural building member

When the procedure described in this test method is carried out on constructions described in 6.4 the results obtained may be applied to other structural columns in accordance with Table 2 by taking into account both cavity and surface limiting temperatures.

Table 2 — Application of results from tests to other combinations of materials

Material from which test column constructed	Results applicable to vertical structural building members constructed from alternative material types when tested with a defined furnace closure, provided 15.2 to 15.6 are satisfied.			
[see 6.4.1]	Steel	Normal concrete	Steel / concrete composite	Timber
Steel [see 6.4.1 a)]	YES	YES	YES	YES
Normal concrete [see 6.4.1 b)]	NO	YES	NO	NO
Steel/concrete composite [see 6.4.1 c)]	NO	YES	YES	NO
Timber [see 6.4.1 d)]	YES ^a	YES ^a	YES ^a	YES
^a Only for the duration to get 300 °C inside the cavity during the fire test of the timber member protected by the same vertical protective membrane.				

Any tests carried out on actual structural building members to be used in practice as defined in 6.1 and 6.4.2 and not carried out on the standard members as defined in 6.4.1, shall be applicable only to that building member tested.

Table 3 provides the specified limiting temperatures for each type of material of building construction according to the types of materials with which the test columns were constructed. The results of the assessment may also be presented according to Table 3.

Table 3 — Limiting temperature values and presentation of results

Material from which test column constructed	Type of closure opposite to vertical protective membrane	Specified limiting temperature value (cavity) [°C]	Specified limiting temperature value (surface) [°C]	Time to specified temperature value (cavity) [minutes]	Time to specified temperature value (surface) [minutes]	Loadbearing capacity [minutes] (Note)
Concrete	Describe	600	-		-	
Steel	Describe	530	510			
Steel/concrete composite	Describe	400	350			
Cold formed steel members	Describe	370	350			
Timber	Describe	300	-		-	
NOTE Loadbearing capacity performance is the lowest value of time to reach the specified limiting temperature in either the cavity or at the surface or the time to reach the specified limiting temperature within the cavity if no surface limiting temperature is given in this table.						

Where building members contain a combination of the material types then the lowest limiting temperature value appropriate to those materials shall be chosen.

15.2 Type of steel column

According to direct applications under 15.1, Tables 2 and 3.

Fire resistance obtained from a test with steel column shall be applicable to assemblies containing steel columns having a section factor lower than that tested.

Fire resistance obtained from a test with timber column shall be applicable to assemblies containing steel columns having any section factor.

The permitted application with respect to the cavity defined in 15.7 shall be allowed.

15.3 Size of concrete column

According to direct applications under 15.1, Tables 2 and 3.

Fire resistance (time to get the limiting 600 °C cavity temperature) obtained from the test on a steel column shall be applicable to concrete columns having cross section dimensions equal to or greater than the tested steel column.

Fire resistance obtained (time to get the limiting cavity temperature) from the test on a concrete column shall be applicable to concrete columns having cross section dimensions equal to or greater than the tested concrete column.

Fire resistance (time to get the limiting cavity temperature) obtained from the test on a hollow steel/composite column shall be applicable to concrete columns having cross section dimensions equal to or greater than the tested hollow steel/composite column.

Fire resistance obtained (time to get 300 °C limiting cavity temperature) from the test on a timber column shall be applicable to concrete columns having any cross-section.

15.4 Size of concrete filled hollow steel composite column

According to direct applications under 15.1, Tables 2 and 3.

Fire resistance (lowest time to get either the limiting cavity temperature or the surface limiting temperature) obtained from the test on a hollow steel composite column shall be applicable to hollow steel composite columns having cross section dimensions equal to or greater than the tested hollow steel composite column.

Fire resistance (time to get the limiting cavity temperature) obtained from a test with steel column shall be applicable to assemblies containing hollow steel composite columns having cross section dimensions equal to or greater than the tested steel column.

Fire resistance (time to get 300 °C limiting cavity temperature) obtained from the test on a timber column shall be applicable to hollow steel composite columns having any cross-section.

15.5 Type of concrete

Where concrete of different strength grade or that prepared from non-silicious aggregate has been used in the concrete or concrete filled hollow steel test column, the applicability of the results shall be restricted according to prEN 13381-3 and EN 13381-6, respectively.

15.6 Timber column

Fire resistance obtained from the test and permitted direct applications obtained under 15.1 shall be directly applicable to all other timber structures, provided that the fire resistance result had been derived from measurement of cavity temperature.

15.7 Depth of the cavity

Fire resistance obtained by direct application shall be applicable to the product in use where the cavity formed between the vertical protective membrane and the practical closure opposite to the membrane is of equal or greater depth than that tested, provided no changes are made to the support of the vertical protective membrane.

15.8 Type of closure opposite to the vertical protective membrane

Loadbearing capacity obtained by direct application shall be applicable only to the product in use in situations where the closure opposite to the vertical protective membrane is of equal or lower insulation potential than that tested.

If a non-standard furnace closure was tested and insulation performance assessed, this insulation performance is no valid anymore for an alternative closure which is of lower insulation potential than that tested.

Where the vertical membrane is to be used in circumstances where the rear face is of greater insulation potential than that tested then a new test shall be performed.

The above two criteria shall both apply to situations where a vertical protective membrane is designed to protect two or more sides of a structural building member.

15.9 Properties of the vertical protective membrane

The result of the assessment is only applicable to the vertical protective membrane construction tested and at the density and thickness tested.

15.10 Size of the vertical protective membrane

The width of the vertical protective membrane may be increased if the specimen was tested at a minimum of 3 m wide with one vertical edge without restraint and in accordance with 6.1

The height of the vertical protective membrane shall be submitted to the same rules as specified in field of application of EN 1364-1.

15.11 Size of panels within the vertical protective membrane

Where panels are produced in a range of sizes and if the minimum and maximum sizes are tested, in separate tests, then the results giving the lowest value are applicable to all intermediate sizes.

15.12 Fixtures and fittings

When fixtures and fittings which may influence the fire resistance are to be inserted into a vertical protective membrane tested without such fittings then the result is not directly applicable. A separate test, including the fixtures and fittings as defined in 6.1 shall be required. Fixtures and fittings at intermediate spacings may be directly applied as a result of this additional test.

15.13 Applicability of results from test columns to beams or combined column /beam structural building members

The result of the assessment is only applicable to beams and beams supported upon columns when there is to be no mechanical contact or attachment of the beam to the vertical protective membrane in use.

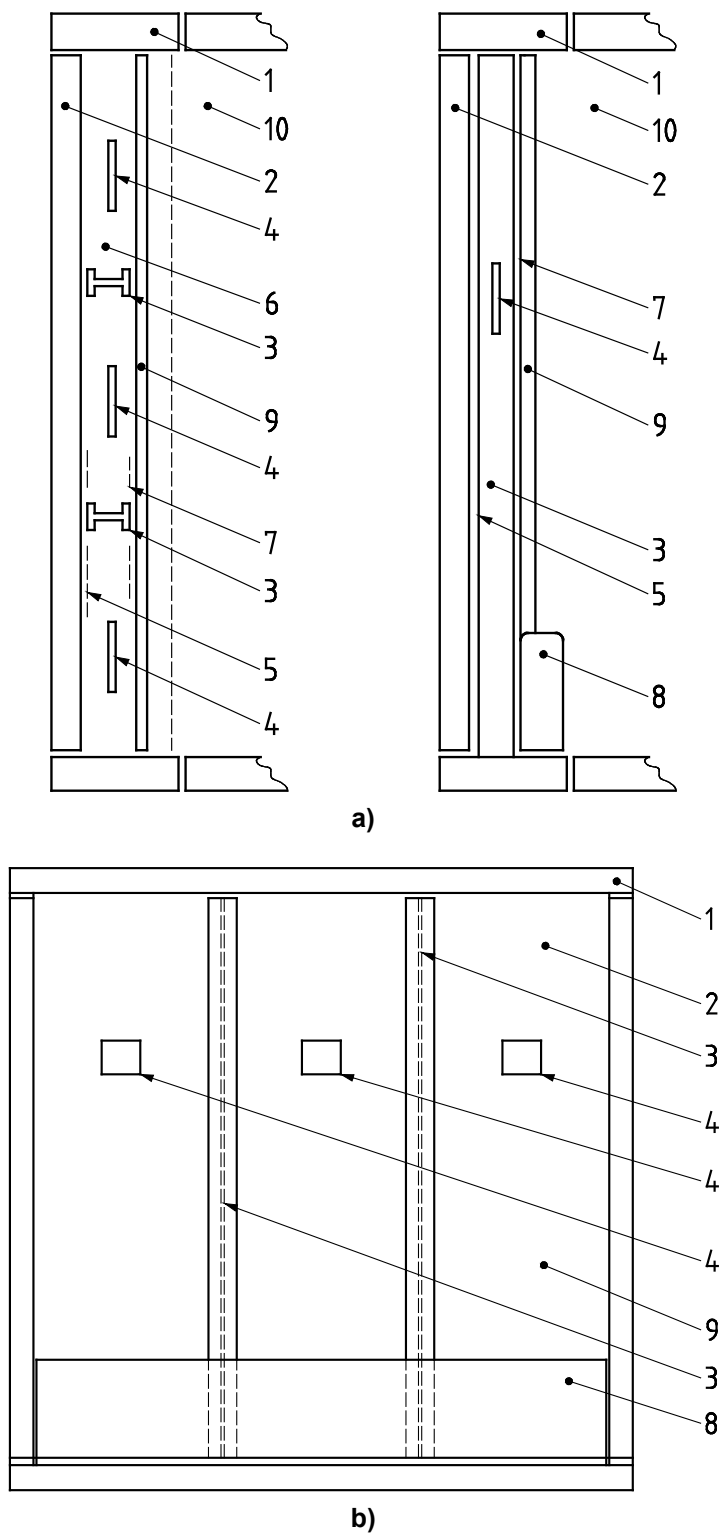

Key

- | | |
|----------------------------------|--------------------------------|
| 1 test frame | 6 cavity |
| 2 furnace closure | 7 separating gap (> 5 mm) |
| 3 steel column | 8 supporting construction |
| 4 plate thermometer (optional) | 9 vertical protective membrane |
| 5 clear space (20 ± 10) mm | 10 furnace |

Figure 1 — Test construction (example showing two steel columns)

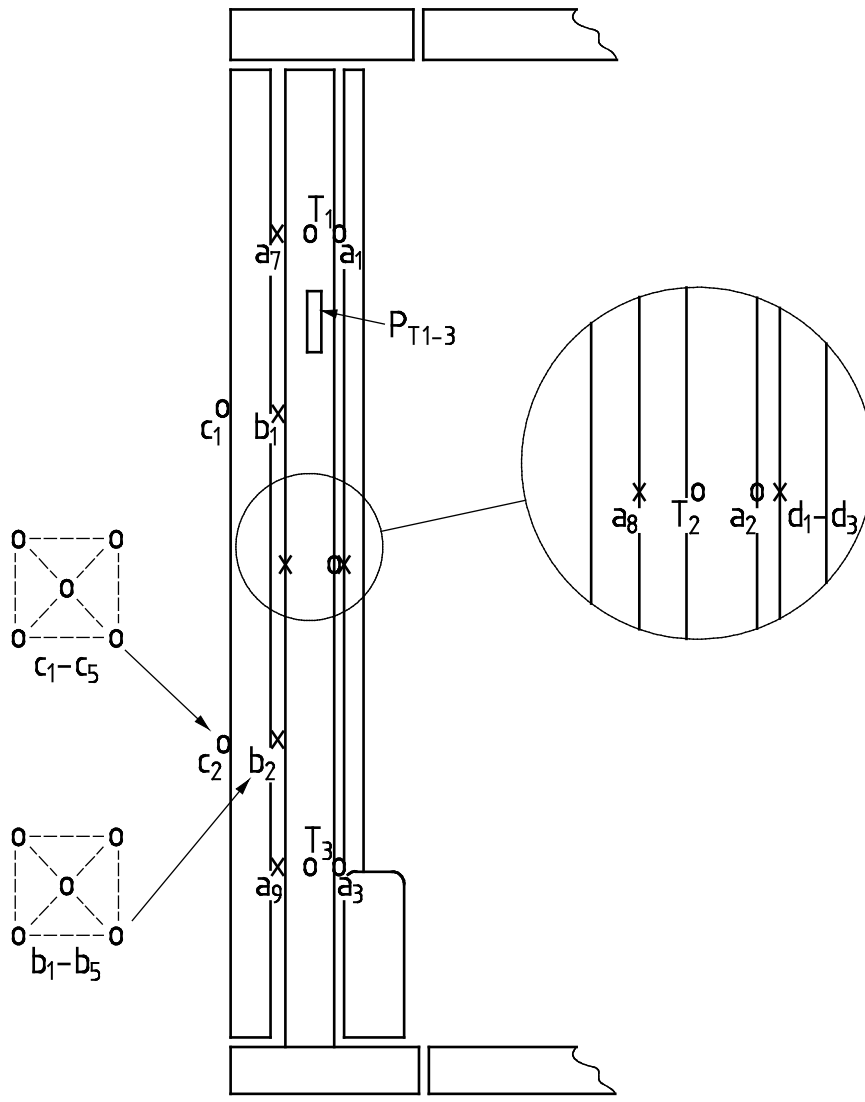

a)

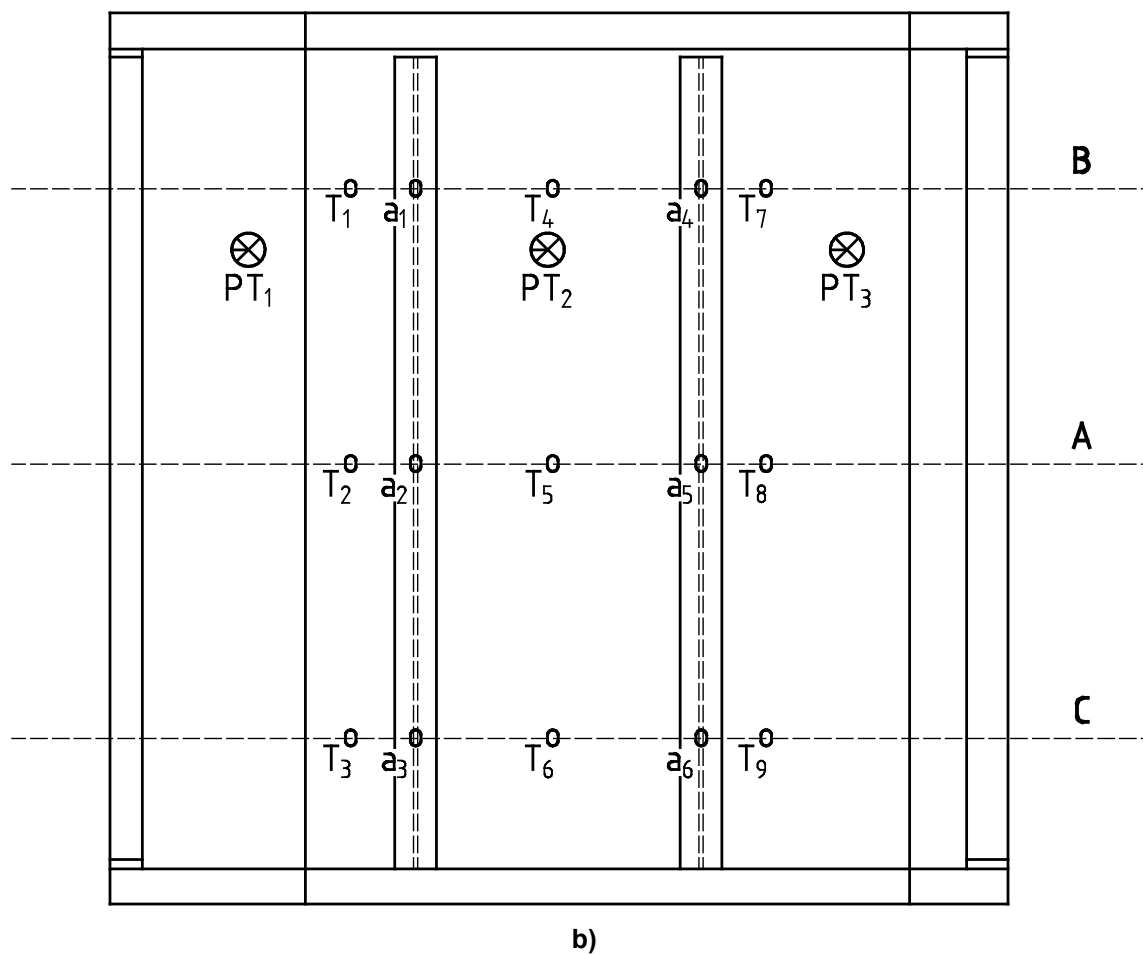

Key

- | | | |
|-----------|--------|--|
| A | Area 1 | optional thermocouples |
| B | Area 2 | a7 - a12 surface thermocouples |
| C | Area 3 | (column - rear face) Mandatory thermocouples |
| b1 - b5 | | furnace closure |
| T1 - T9 | | cavity thermocouples (inside cavity) |
| a1 - a6 | | surface thermocouples |
| d1 - d3 | | vertical membrane(column-front face) (unexposed surface) |
| c1 - c5 | | unexposed surface |
| PT1 - PT3 | | plate thermometers |

Figure 2 — Location of mandatory thermocouples and optional thermocouples

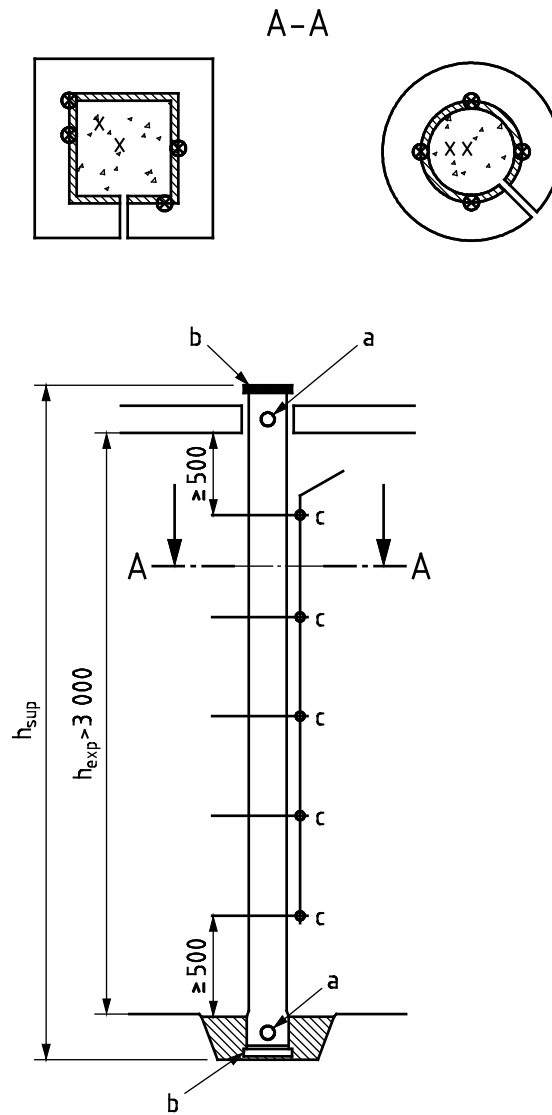

Key

- ⊗ thermocouple on steel surface (mandatory)
- x thermocouple within concrete (optional)

a 20 mm hole for steam venting

b 20 mm plate welded to column

c temperature measurement station

h_{exp} exposed height

(For general column test arrangement see EN 1365-4)

Figure 3 — Concrete filled hollow steel column

Annex A (normative)

Measurement of properties of vertical protective membranes and components

A.1 General

Determination of the thickness, density and moisture content of vertical protective membranes, components thereof and other materials used in this fire resistance test is important to the accurate prediction of fire protection performance from the test result. The methods used to establish these properties shall, therefore, be consistent and this annex gives guidance on appropriate procedures to be used.

Any special test samples used to determine thickness, density and moisture content shall be conditioned as described in Clause 8.

Any specific product standard existing for the measurement of such properties shall be followed.

The procedures given in EN 1363-1 shall be followed together with the requirements of A.2 to A.4.

A.2 Thickness of vertical protective membrane and components thereof

A.2.1 For vertical protective membranes containing board or panel materials, the nominal thickness of each material shall be measured using suitable gauges or callipers.

The measurement shall be carried out either on the actual materials during assembly of the test specimen or on a representative special test sample, the minimum linear dimensions of which shall be 300 mm × 300 mm. At least nine measurements shall be made including measurements around the perimeter and over the surface of the material.

The design thickness used in the assessment shall be as described in 6.5.

A.2.2 For vertical protective membranes containing sprayed passive fire protection materials applied on a solid surface, the thickness of this component shall be measured using a 1 mm diameter probe or drill, which shall be inserted into the material at each measurement position until the tip of the probe or drill touches the surface of the building element. The probe or drill shall carry a circular steel plate of diameter 50 mm upon it, for accurate determination of the surface level.

In case where there is a gap between the membrane and the structural member and it is not possible to use the probe, then use additional standard steel plate, of size (300 x 300) mm as explained in A.2.3 b).

Thickness measurement points shall be located on the vertical protective membrane at points corresponding to each of the main cavity temperature measuring locations, T1 to T9. They shall be regarded as the minimum number of thickness measurement points.

For vertical protective membranes containing sprayed fire protection materials, the design thickness used in the assessment shall be as specified in 6.5.

A.2.3 For vertical protective membranes containing reactive fire protection coating materials, the dry film thickness of that component shall be determined by at least two of the following methods. In all cases the design and thickness used in the assessment shall be as specified in 6.5.

- a) Fixing of at least nine steel plates of size 100 mm × 100 mm and 1 mm thickness to the vertical protective membrane structure, before the fire protection material is applied. The dry film thickness of the material applied to each of these is measured. These shall not be placed in critical positions with respect to temperature measurement.
- b) Interpolation from that measured on a standard steel plate, of size 300 mm × 300 mm, to which the coating is applied at the same time and by the same method as it is applied to the vertical protective membrane structure. Measurements shall be made at nine points over the steel plate at least, including measurements around the perimeter and over the surface of the material.

The dry film thickness of reactive fire protection coatings over steel plates (methods a) or b)) shall be measured using an instrument employing either the electro-magnetic induction principle or the eddy current principle. Reactive fire protection materials applied as coatings typically range from 0,25 mm to 4 mm thickness and the choice of instrument shall be appropriate to the thickness of coating used.

- c) Interpolation by examination of the wet film applied at the same time and by the same method to a standard steel plate, of size 300 mm × 300 mm, as it is applied to the vertical protective membrane. Dry film thickness may be measured by:
 - 1) determining the mass of material applied per unit area and hence applied wet film thickness. Interpolation to dry film thickness using expected mass loss / thickness loss specified by sponsor;
 - 2) use of wet film thickness combs to give wet film thickness. Interpolation of this using expected thickness loss to dry film thickness.
- d) Other verifiable methods proposed by the sponsor.

A.3 Density of vertical protective membranes and components thereof

A.3.1 General

The density of each component of the vertical protective membrane shall be determined from measurements of mass and dimensions using the following:

A.3.2 For vertical protective membranes containing board or panel materials, the density may be obtained from values of mass, mean thickness (from nine measurements) and area measured either on the actual materials during assembly or on a representative special test sample, the minimum linear dimensions of which shall be 300 mm × 300 mm. The mass of the board shall be obtained using a balance having an accuracy equivalent to 0,1 % of the total mass of the sample being weighed or 0,1 g (the sample size shall be sufficient such that the minimum mass is 100 g) whichever is the greater.

The density of fibrous or compressible fire protection material shall be related to nominal thickness.

A.3.3 For vertical protective membranes containing spray applied fire protection materials, the density of these materials shall be determined from samples of the material sprayed, into two 300 mm × 300 mm metal trays, made from 1 mm thick steel plate. The depth of the trays shall be the same as the design thickness of the spray applied protection.

They shall be prepared in the same manner, orientation and at the same time, as that applied to the vertical protective membrane system. For each thickness of fire protection material two such trays shall be prepared. One of these trays is dried to provide a reference for dry density and moisture content. The second tray shall be used to determine the density at the time of test.

The thickness of the specimen within the trays shall be determined at nine points over the surface of the trays according to:

- one at the centre;
- two along each centre to corner axis, equidistant from each other, the centre and the corner.

The mass of the fire protection within the tray shall be obtained using a balance having an accuracy equivalent to 0,1 % of the total mass of the sample being weighed or 0,1 g (the sample size shall be sufficient such that the minimum mass is 100 g, whichever is the greater).

A.3.4 The design density used in the assessment in all cases shall be as defined in 6.5.

A.4 Moisture content of vertical protective membrane and components thereof

A.4.1 The samples and materials used to measure moisture content shall be stored together with and under the same conditions as the test specimens. The measurement of final moisture content shall be made on the day that fire testing takes place.

A.4.2 For vertical protective membranes containing board or panel materials, special test samples shall be taken measuring minimum 300 mm × 300 mm at each thickness of the material used. They shall be weighed [initial conditioned mass, (W_1)] and then heated in a ventilated oven at (105 ± 2) °C for 24 h, cooled and then re-weighed.

However, for gypsum based and similar materials, drying shall take place at (40 ± 5) °C.

Repeated weighings shall be taken until moisture equilibrium or constant mass, (W_2), as defined in EN 1363-1, is reached. The moisture content ($W_1 - W_2$) of the specimens shall be calculated as a % of its moisture equilibrium or constant mass.

A.4.3 For vertical protective membranes containing spray applied passive fire protection materials, the moisture content of the material shall be calculated from repeated weighing / heating / weighing of one of the sample trays referred to in A.3.3 above, for each thickness tested.

The sample trays shall be weighed [initial conditioned mass (W_1)], heated in a ventilated oven at (105 ± 2) °C for 24 h, cooled and then re-weighed. Repeated weighings shall be taken until moisture equilibrium or constant mass, (W_2), as defined in EN 1363-1, is reached. The moisture content ($W_1 - W_2$) of the specimen shall be calculated as a % of its moisture equilibrium or constant mass.

Should the product contain, or be based on, gypsum and similar materials drying shall take place at (40 ± 5) °C.

Annex B (normative)

Test method to the smouldering fire (slow heating curve)

B.1 Introduction

Fire protection products activated by the heat flux of the fire may be required to be subjected to a test to a smouldering curve (slow heating curve as defined in EN 1363-2), with a rate of temperature increase less than that of the standard temperature/time curve.

NOTE See Council Directive 89/106/EEC, ID No. 2: Safety in case of fire, Clauses 3.2.4 and 4.3.1.3.4 (b).

This exposure, applicable to reactive fire protection materials, is used only in special circumstances, where it might be expected that the performance of the product when exposed to a smouldering fire might be substantially less than when it is exposed to the standard temperature/time curve, and where such a test is specified in the national building regulations of the Member State of destination.

It is not intended to be mandatory for all fire protection materials applied to structural steel members.

B.2 Test equipment

The furnace and test equipment shall be designed to permit the test specimens to be exposed to heating as specified within B.5.

The smouldering curve (slow heating curve) shall be as specified in EN 1363-2, where it provides a heating regime wherein during the period $t = 0$ min to 20 min the furnace temperature (T) follows the relationship:

$$T = 154 \sqrt[4]{t} + 20$$

After $t = 20$ min and for the remainder of the test, the furnace temperature (T) follows the temperature/time relationship:

$$T = 345 \log_{10}[8(t - 20) + 1] + 21$$

This heating protocol is shown graphically in Figure B.1.

B.3 Test specimens

The test specimen, together with any associated construction, shall be as described in Clause 6.

B.4 Termination of test

Terminate the test after 40 min or if it becomes unsafe to continue according to EN 1363-1.

B.5 Evaluation of the results

The characteristic temperature of the cavity when subjected to both the standard temperature/time curve (according to the principal test) and the smouldering curve (this test) shall be compared each with the other.

The results from the characteristic temperature in the cavity shall be examined and recorded by tabulation.

The results shall be presented graphically, in a manner similar to that given in Figure B.1, and the performance of the fire protection material to the two fire sources compared and recorded.

The values of ΔT_1 and ΔT_2 shall be measured and recorded.

The results of tests carried out according to the standard temperature/time curve for the particular reactive fire protection material under test shall only be valid and applicable if $\Delta T_1 > \Delta T_2$.

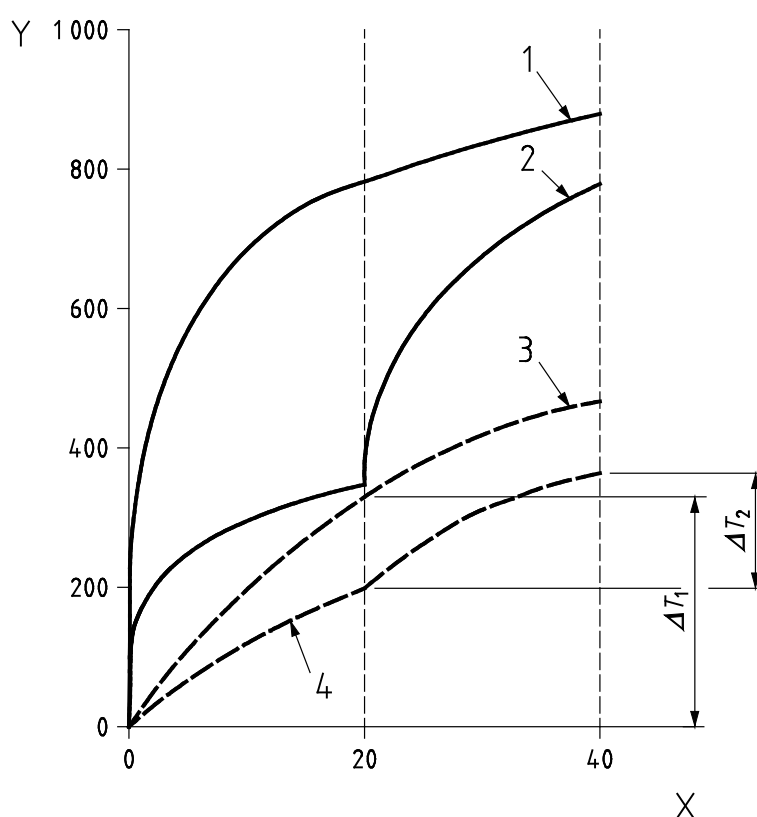

Key

- Y temperature (°C)
- X time (min)
- 1 standard temperature/time curve
- 2 smouldering (slow heating) curve
- 3 test element temperature to standard temperature/time curve
- 4 test element temperature to smouldering (slow heating) curve

Figure B.1 — Comparison of performance to the standard and smouldering fire curves

Bibliography

EN 1365-4, *Fire resistance tests for loadbearing elements - Part 4: Columns*

British Standards Institution (BSI)

BSI is the national body responsible for preparing British Standards and other standards-related publications, information and services.

BSI is incorporated by Royal Charter. British Standards and other standardization products are published by BSI Standards Limited.

About us

We bring together business, industry, government, consumers, innovators and others to shape their combined experience and expertise into standards-based solutions.

The knowledge embodied in our standards has been carefully assembled in a dependable format and refined through our open consultation process. Organizations of all sizes and across all sectors choose standards to help them achieve their goals.

Information on standards

We can provide you with the knowledge that your organization needs to succeed. Find out more about British Standards by visiting our website at bsigroup.com/standards or contacting our Customer Services team or Knowledge Centre.

Buying standards

You can buy and download PDF versions of BSI publications, including British and adopted European and international standards, through our website at bsigroup.com/shop, where hard copies can also be purchased.

If you need international and foreign standards from other Standards Development Organizations, hard copies can be ordered from our Customer Services team.

Subscriptions

Our range of subscription services are designed to make using standards easier for you. For further information on our subscription products go to bsigroup.com/subscriptions.

With **British Standards Online (BSOL)** you'll have instant access to over 55,000 British and adopted European and international standards from your desktop. It's available 24/7 and is refreshed daily so you'll always be up to date.

You can keep in touch with standards developments and receive substantial discounts on the purchase price of standards, both in single copy and subscription format, by becoming a **BSI Subscribing Member**.

PLUS is an updating service exclusive to BSI Subscribing Members. You will automatically receive the latest hard copy of your standards when they're revised or replaced.

To find out more about becoming a BSI Subscribing Member and the benefits of membership, please visit bsigroup.com/shop.

With a **Multi-User Network Licence (MUNL)** you are able to host standards publications on your intranet. Licences can cover as few or as many users as you wish. With updates supplied as soon as they're available, you can be sure your documentation is current. For further information, email bsmusales@bsigroup.com.

BSI Group Headquarters

389 Chiswick High Road London W4 4AL UK

Revisions

Our British Standards and other publications are updated by amendment or revision.

We continually improve the quality of our products and services to benefit your business. If you find an inaccuracy or ambiguity within a British Standard or other BSI publication please inform the Knowledge Centre.

Copyright

All the data, software and documentation set out in all British Standards and other BSI publications are the property of and copyrighted by BSI, or some person or entity that owns copyright in the information used (such as the international standardization bodies) and has formally licensed such information to BSI for commercial publication and use. Except as permitted under the Copyright, Designs and Patents Act 1988 no extract may be reproduced, stored in a retrieval system or transmitted in any form or by any means – electronic, photocopying, recording or otherwise – without prior written permission from BSI. Details and advice can be obtained from the Copyright & Licensing Department.

Useful Contacts:

Customer Services

Tel: +44 845 086 9001

Email (orders): orders@bsigroup.com

Email (enquiries): cservices@bsigroup.com

Subscriptions

Tel: +44 845 086 9001

Email: subscriptions@bsigroup.com

Knowledge Centre

Tel: +44 20 8996 7004

Email: knowledgecentre@bsigroup.com

Copyright & Licensing

Tel: +44 20 8996 7070

Email: copyright@bsigroup.com



...making excellence a habit.™