

BS EN 13362:2013



BSI Standards Publication

Geosynthetic barriers — Characteristics required for use in the construction of canals

bsi.

...making excellence a habit.™

National foreword

This British Standard is the UK implementation of EN 13362:2013. It supersedes BS EN 13362:2005 which is withdrawn.

The UK participation in its preparation was entrusted to Technical Committee B/553, Geotextiles and geomembranes.

A list of organizations represented on this committee can be obtained on request to its secretary.

This publication does not purport to include all the necessary provisions of a contract. Users are responsible for its correct application.

© The British Standards Institution 2013. Published by BSI Standards Limited 2013

ISBN 978 0 580 79929 7

ICS 59.080.70; 91.100.50

Compliance with a British Standard cannot confer immunity from legal obligations.

This British Standard was published under the authority of the Standards Policy and Strategy Committee on 31 July 2013.

Amendments issued since publication

Date	Text affected
------	---------------

EUROPEAN STANDARD

EN 13362

NORME EUROPÉENNE

EUROPÄISCHE NORM

July 2013

ICS 59.080.70; 91.100.50

Supersedes EN 13362:2005

English Version

Geosynthetic barriers - Characteristics required for use in the construction of canals

Géomembranes, géosynthétiques bentonitiques -
Caractéristiques requises pour l'utilisation dans la
construction des canaux

Geosynthetische Dichtungsbahnen - Eigenschaften, die für
die Anwendung beim Bau von Kanälen erforderlich sind

This European Standard was approved by CEN on 23 May 2013.

CEN members are bound to comply with the CEN/CENELEC Internal Regulations which stipulate the conditions for giving this European Standard the status of a national standard without any alteration. Up-to-date lists and bibliographical references concerning such national standards may be obtained on application to the CEN-CENELEC Management Centre or to any CEN member.

This European Standard exists in three official versions (English, French, German). A version in any other language made by translation under the responsibility of a CEN member into its own language and notified to the CEN-CENELEC Management Centre has the same status as the official versions.

CEN members are the national standards bodies of Austria, Belgium, Bulgaria, Croatia, Cyprus, Czech Republic, Denmark, Estonia, Finland, Former Yugoslav Republic of Macedonia, France, Germany, Greece, Hungary, Iceland, Ireland, Italy, Latvia, Lithuania, Luxembourg, Malta, Netherlands, Norway, Poland, Portugal, Romania, Slovakia, Slovenia, Spain, Sweden, Switzerland, Turkey and United Kingdom.



EUROPEAN COMMITTEE FOR STANDARDIZATION
COMITÉ EUROPÉEN DE NORMALISATION
EUROPÄISCHES KOMITEE FÜR NORMUNG

Management Centre: Avenue Marnix 17, B-1000 Brussels

Contents

Page

Foreword.....	4
Introduction	5
1 Scope	6
2 Normative references	6
3 Terms, definitions and abbreviations	8
3.1 Terms and definitions	8
3.2 Abbreviations	9
4 Required characteristics and corresponding methods of test	9
4.1 General.....	9
4.2 Types of application	9
4.2.1 General.....	9
4.2.2 Application 1: "covered in service"	9
4.2.3 Application 2: "not covered in service"	11
4.3 Relevant characteristics	11
4.4 Characteristics relevant to specific conditions of use	16
4.4.1 General.....	16
4.4.2 Tear strength	16
4.4.3 Burst strength	16
4.4.4 Friction characteristics (direct shear and inclined plane tests)	16
4.4.5 Low temperature behaviour.....	16
4.4.6 Weathering	16
4.4.7 Resistance to wetting and drying	17
4.4.8 Freeze-thaw cycle resistance	17
4.4.9 Resistance to root penetration.....	17
4.4.10 Chemical resistance	17
4.5 Release of dangerous substances.....	17
5 Evaluation of conformity.....	17
5.1 Presentation of characteristics	17
5.2 Verification of values.....	17
5.3 Initial type tests.....	18
5.4 Factory production control.....	18
5.5 Inspection	19
6 Marking	19
Annex A (normative) Factory production control — Factory production control scheme	20
A.1 General.....	20
A.2 Product design.....	20
A.3 Production	20
A.3.1 Raw or incoming materials	20
A.3.2 Production process	20
A.4 Finished products.....	20
A.4.1 Raw or incoming materials	20
A.4.2 Alternative tests	23
A.4.3 Equipment	23
A.4.4 Provisions applicable to A.2, A.3 and A.4 (to be used where appropriate)	24
Annex B (normative) Durability of geosynthetic barriers	25
B.1 Introduction	25
B.1.1 Standards to which this annex is common.....	25
B.1.2 Mechanisms of degradation	25
B.1.3 Service life	26

B.1.4	Use of rework materials	26
B.2	Test requirements.....	26
B.2.1	General requirement.....	26
B.2.2	Requirements for repeat testing	26
B.2.3	Requirements for individual materials	27
B.3	Durability tests.....	28
B.3.1	Introduction.....	28
B.3.2	Weathering	28
B.3.3	Resistance to micro-organisms	30
B.3.4	Resistance to environmental stress cracking	30
B.3.5	Resistance to leaching.....	30
B.3.6	Resistance to oxidation	31
B.3.7	Chemical resistance	31
B.4	Evaluation tests and acceptance criteria	31
B.4.1	General.....	31
B.4.2	Evaluation by comparison of tensile properties	31
B.4.3	Evaluation by comparison of Oxidative Induction Time (OIT) values.....	32
B.4.4	Evaluation by change in mass	32
B.4.5	Evaluation by change in water permeability.....	32
Annex ZA	(informative) Clauses of this European Standard addressing the provisions of the EU Construction Products Directive.	33
ZA.1	Scope and relevant characteristics	33
ZA.2	Procedure for attestation of conformity of geosynthetic barriers	34
ZA.2.1	System of attestation of conformity	34
ZA.2.2	EC Certificate and Declaration of Conformity	35
ZA.3	CE marking and labelling.....	36
Bibliography	39

Foreword

This document (EN 13362:2013) has been prepared by Technical Committee CEN/TC 189 “Geosynthetics”, the secretariat of which is held by NBN.

This European Standard shall be given the status of a national standard, either by publication of an identical text or by endorsement, at the latest by January 2014, and conflicting national standards shall be withdrawn at the latest by January 2014.

Attention is drawn to the possibility that some of the elements of this document may be the subject of patent rights. CEN [and/or CENELEC] shall not be held responsible for identifying any or all such patent rights.

This document supersedes EN 13362:2005.

The following technical changes were introduced in comparison with the previous edition:

- The normative references were updated.
- Table 1 was revised.
- “Chemical resistance” was added to Clause 4.
- “Release of dangerous substances” was added to Clause 4.
- Annex A revised: “raw or incoming material” and Tables A.1 to A.3 were added.
- Annex B was revised.

This document has been prepared under a mandate given to CEN by the European Commission and the European Free Trade Association, and supports essential requirements of EU Directive(s).

For relationship with EU Directive(s), see informative Annex ZA, which is an integral part of this document.

According to the CEN-CENELEC Internal Regulations, the national standards organisations of the following countries are bound to implement this European Standard: Austria, Belgium, Bulgaria, Croatia, Cyprus, Czech Republic, Denmark, Estonia, Finland, Former Yugoslav Republic of Macedonia, France, Germany, Greece, Hungary, Iceland, Ireland, Italy, Latvia, Lithuania, Luxembourg, Malta, Netherlands, Norway, Poland, Portugal, Romania, Slovakia, Slovenia, Spain, Sweden, Switzerland, Turkey and the United Kingdom.

Introduction

This European Standard allows manufacturers to describe geosynthetic barriers on the basis of declared values for characteristics relevant to the intended use and if tested to the specified method. It also includes procedures for evaluation of conformity and factory production control.

This European Standard may also be used by designers, end-users and other interested parties as a tool to define relevant and appropriate characteristics for specifications and on-site quality control. It should be emphasised however that not all characteristics and test methods quoted in this document are suitable for the purpose of on-site quality control.

Tests for several non-mandated characteristics are still under study and will be included when the standard is revised.

The term “product” used in this document refers to a geosynthetic barrier, including polymeric geosynthetic barriers, clay geosynthetic barriers and bituminous geosynthetic barriers.

This European Standard is part of a group of standards, addressing the requirements for geosynthetic barriers when used in a specific application.

Particular application cases may contain requirements about additional properties and - preferably standardised - test methods, if they are technically relevant and not conflicting with European Standards.

The design life of the product should be determined, since its function may be temporary, as a construction expediency, or permanent, for the lifetime of the structure.

1 Scope

This European Standard specifies the relevant characteristics of geosynthetic barriers, including polymeric geosynthetic barriers, clay geosynthetic barriers and bituminous geosynthetic barriers, when used as fluid barriers for potable, fresh or saline water, in the construction of canals, and the appropriate test methods to determine these characteristics.

The intended use of these products is to control the leakage of water through the construction.

This European Standard is not applicable to geotextiles or geotextile-related products.

This European Standard provides for the evaluation of conformity of the product to this European Standard.

This European Standard defines requirements to be met by manufacturers and their authorised representatives with regard to the presentation of product properties.

This European Standard does not cover applications where the geosynthetic barrier is to be in contact with water that has been treated for human consumption.

Where potable water is or may be in direct contact with the product the designer should also refer to other relevant standards, requirements and/or regulations.

2 Normative references

The following documents, in whole or in part, are normatively referenced in this document and are indispensable for its application. For dated references, only the edition cited applies. For undated references, the latest edition of the referenced document (including any amendments) applies.

EN 495-5, *Flexible sheets for waterproofing — Determination of foldability at low temperature — Part 5: Plastic and rubber sheets for roof waterproofing*

EN 1109, *Flexible sheets for waterproofing — Bitumen sheets for roof waterproofing — Determination of flexibility at low temperature*

EN 1844, *Flexible sheets for waterproofing — Determination of resistance to ozone — Plastic and rubber sheets for roof waterproofing*

EN 1849-1, *Flexible sheets for waterproofing — Determination of thickness and mass per unit area — Part 1: bitumen sheets for roof waterproofing*

EN 1849-2, *Flexible sheets for waterproofing — Determination of thickness and mass per unit area — Part 2: Plastic and rubber sheets*

EN 12224, *Geotextiles and geotextile-related products — Determination of the resistance to weathering*

EN 12225, *Geotextiles and geotextile-related products — Method for determining the microbiological resistance by a soil burial test*

EN 12310-1, *Flexible sheets for waterproofing — Part 1: Bitumen sheets for waterproofing — Determination of resistance to tearing (nail shank)*

EN 12311-1, *Flexible sheets for waterproofing — Part 1: Bitumen sheets for roof waterproofing — Determination of tensile properties*

EN 12311-2, *Flexible sheets for waterproofing — Determination of tensile properties — Part 2: Plastic and rubber sheets for roof waterproofing*

- EN 13361, *Geosynthetic barriers — Characteristics required for use in the construction of reservoirs and dams*
- EN 13491, *Geosynthetic barriers — Characteristics required for use as a fluid barrier in the construction of tunnels and underground structures*
- EN 13492, *Geosynthetic barriers — Characteristics required for use in the construction of liquid waste disposal sites, transfer stations or secondary containment*
- EN 13493, *Geosynthetic barriers — Characteristics required for use in the construction of solid waste storage and disposal sites*
- EN 14150, *Geosynthetic barriers — Determination of permeability to liquids*
- EN 14151, *Geosynthetics — Determination of burst strength*
- EN 14196, *Geosynthetics — Test methods for measuring mass per unit area of clay geosynthetic barriers*
- EN 14414:2004, *Geosynthetics — Screening test method for determining chemical resistance for landfill applications*
- EN 14415, *Geosynthetic barriers — Test method for determining the resistance to leaching*
- CEN/TS 14416, *Geosynthetic barriers — Test method for determining the resistance to roots*
- CEN/TS 14417, *Geosynthetic barriers — Test method for the determination of the influence of wetting-drying cycles on the permeability of clay geosynthetic barriers*
- CEN/TS 14418, *Geosynthetic barriers — Test method for the determination of the influence of freezing-thawing cycles on the permeability of clay geosynthetic barriers*
- EN 14575, *Geosynthetic barriers — Screening test method for determining the resistance to oxidation*
- EN 14576, *Geosynthetics — Test method for determining the resistance of polymeric geosynthetic barriers to environmental stress cracking*
- EN 15382, *Geosynthetic barriers — Characteristics required for use in transportation infrastructure*
- EN 16416, *Geosynthetic clay barriers — Determination of water flux index — Flexible wall permeameter method at constant head*
- EN ISO 527-1:2012, *Plastics — Determination of tensile properties — Part 1: General principles (ISO 527-1:2012)*
- EN ISO 527-3:1995, *Plastics — Determination of tensile properties — Part 3: Test conditions for films and sheets (ISO 527-3:1995)*
- EN ISO 527-4:1997, *Plastics — Determination of tensile properties — Part 4: Test conditions for isotropic and orthotropic fibre-reinforced plastic composites (ISO 527-4:1997)*
- EN ISO 9862, *Geosynthetics — Sampling and preparation of test specimens (ISO 9862)*
- EN ISO 9863-1, *Geosynthetics — Determination of thickness at specified pressures — Part 1: Single layers (ISO 9863-1)*
- EN ISO 9864, *Geosynthetics — Test method for the determination of mass per unit area of geotextiles and geotextile-related products (ISO 9864)*
- EN ISO 10318:2005, *Geosynthetics — Terms and definitions (ISO 10318:2005)*
- EN ISO 10319, *Geotextiles — Wide-width tensile test (ISO 10319)*

EN ISO 10320, *Geotextiles and geotextile-related products — Identification on site (ISO 10320)*

EN ISO 11358, *Plastics — Thermogravimetry (TG) of polymers — General principles (ISO 11358)*

EN ISO 12236, *Geosynthetics — Static puncture test (CBR test) (ISO 12236)*

EN ISO 12957-1, *Geosynthetics — Determination of friction characteristics — Part 1: Direct shear test (ISO 12957-1)*

EN ISO 12957-2, *Geosynthetics — Determination of friction characteristics — Part 2: Inclined plane test (ISO 12957-2)*

EN ISO 13438, *Geotextiles and geotextile-related products — Screening test method for determining the resistance to oxidation (ISO 13438)*

ISO 34-1, *Rubber, vulcanized or thermoplastic — Determination of tear strength — Part 1: Trouser, angle and crescent test pieces*

ISO 11357-6, *Plastics — Differential scanning calorimetry (DSC) — Part 6: Determination of oxidation induction time (isothermal OIT) and oxidation induction temperature (dynamic OIT)*

ASTM D696, *Standard test method for coefficient of linear thermal expansion of plastics between -30 °C and 30 °C.*

ASTM D5890, *Standard test method for swell index of clay mineral component of geosynthetic clay liners*

ASTM D6141, *Standard guide for screening clay portion of geosynthetic clay liner (GCL) for chemical compatibility to liquids*

3 Terms, definitions and abbreviations

3.1 Terms and definitions

For the purposes of this document, the terms and definitions given in EN ISO 10318:2005 and the following apply.

3.1.1

product

geosynthetic barrier, including polymeric, bituminous and clay barriers

3.1.2

specification

document in which the works, functions, specific conditions and required material property values of the geosynthetic barrier of use are described

3.1.3

canal

waterway which is intended to convey water from source to user or to be used by boats, ships or barges for commercial or pleasure purposes

Note 1 to entry: The waterway may be an entirely engineered feature or it may be a natural river which has been engineered to improve its capacity as a waterway.

3.1.4

revetment

construction that comprises one or more layers of material to provide protection against erosion

3.1.5

top water level

normal highest water level in the canal

3.2 Abbreviations

For the purposes of this document, the abbreviations of EN ISO 10318:2005 and the following apply:

GBR-P: polymeric geosynthetic barrier

GBR-B: bituminous geosynthetic barrier

GBR-C: clay geosynthetic barrier

4 Required characteristics and corresponding methods of test

4.1 General

The main function of geosynthetic barriers when used in the construction of canals for potable, fresh or saline water is to prevent or reduce the flow of fluid through the structure. Damage during installation has not been addressed in this document.

4.2 Types of application

4.2.1 General

It is not normally advisable to install a geosynthetic barrier on the downstream face of a canal embankment. Special consideration should be given to any geosynthetic barrier installed on the downstream face of a canal. The applications described in this document do not include such situations.

4.2.2 Application 1: "covered in service"

Applications where the product is laid in a canal and is covered in service with a revetment or other protective layers. Figure 1 shows a typical installation.

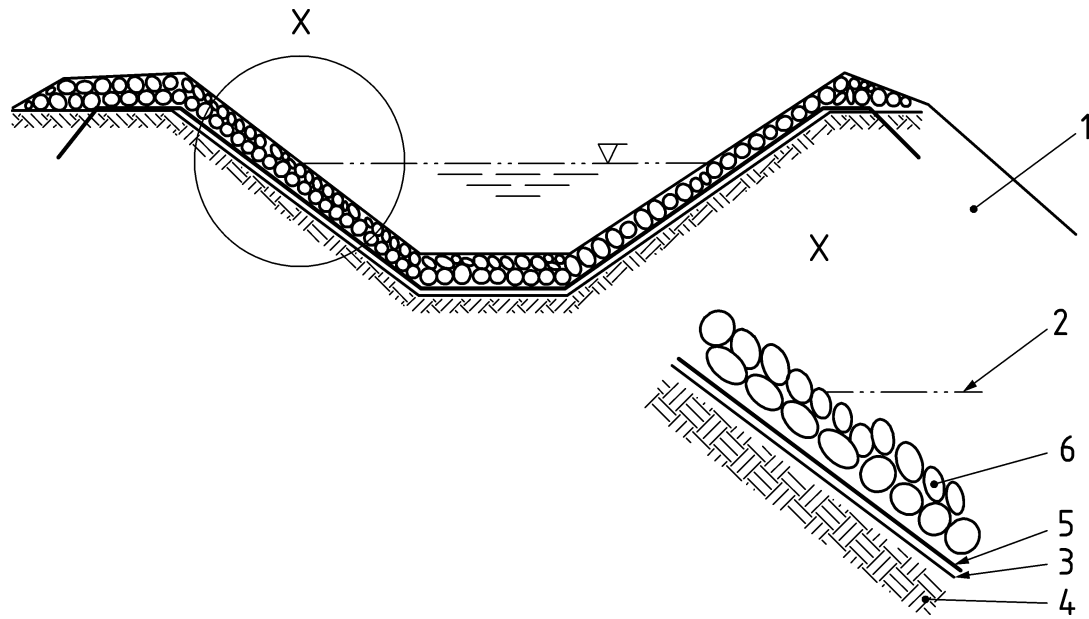

Key

- 1 original ground profile
- 2 top water level
- 3 protection geotextile
- 4 fill embankment
- 5 geosynthetic barrier
- 6 revetment

Figure 1 — Geosynthetic barrier laid as a canal liner on either fill or cut natural soils and covered with a revetment

4.2.3 Application 2: "not covered in service"

As in application 1, but with the product not covered in service with a revetment or other protective layers. Figure 2 shows a typical installation.

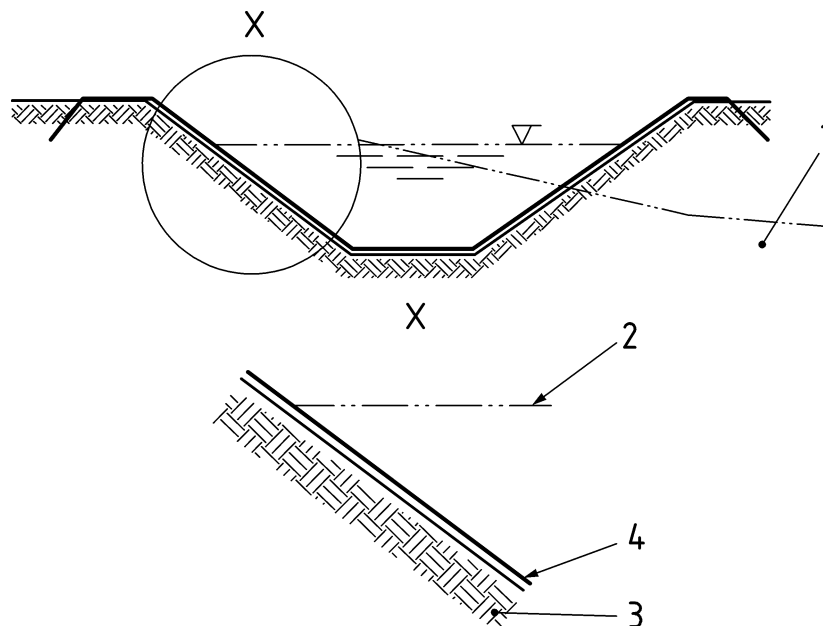

Key

- 1 original ground profile
- 2 top water level
- 3 fill embankment
- 4 geosynthetic barrier

Figure 2 — Geosynthetic barrier laid as a canal liner on either fill or cut natural soils and exposed without any revetment or protection

4.3 Relevant characteristics

The characteristics and the test methods to be used are given in Table 1. The list of characteristics in Table 1 includes those relevant to all conditions of use and subject to harmonisation (H) (see Annex ZA), those relevant to all conditions of use and not subject to harmonisation (A), and those relevant to specific conditions of use and not subject to harmonisation (S).

The functions and conditions of use, corresponding with the characteristics, marked with "S" in Table 1, are specified in 4.4.

The manufacturer shall provide the data based on the results of tests specified in this document and, where relevant, in accordance with 5.1.

The manufacturer shall provide information on how functioning joints can be made. Where products are jointed in the factory the water permeability and if relevant the strength of the joints shall be tested and data presented.

Table 1 — Geosynthetic barriers used in the construction of canals - Functions, function-related characteristics and test methods to be used.

		Covered in service			Not covered in service		Test methods			Remarks
Nr	Property to be tested	GBR-P	GBR-B	GBR-C	GBR-P	GBR-B	GBR-P	GBR-B	GBR-C	
	Physical properties									
1	Thickness	A	A	A	A	A	EN 1849-2	EN 1849-1	EN ISO 9863-1	
2	Mass per unit area	A	A	A	A	A	EN 1849-2	EN 1849-1	EN 14196	
	Hydraulic properties									
3	Water permeability (liquid tightness)	H	H	H	H	H	EN 14150	EN 14150	EN 16416	Report index flux for GBR-C.
4	Swell index	-	-	A	-	-	-	-	ASTM D5890	
	Mechanical properties									
5	Tensile strength	H	H	H	H	H	EN ISO 527-1 EN ISO 527-3 EN ISO 527-4 or EN 12311-2	EN 12311-1	EN ISO 10319	For non-reinforced GBR-P use EN ISO 527-1 and EN ISO 527-3:1995, test specimen type 5 at a speed of 100 mm/min. For reinforced GBR-P use EN ISO 527-1 and EN ISO 527-3:1997, specimen type 2 with width 50 mm, at a speed of 5 mm/min. EN 12311-2 should only be used for non-polyolefinic GBR-P. Report in all cases the maximum strength measured according to the test method.

Table 1 (continued)

Nr	Property to be tested	Covered in service			Not covered in service		Test methods			Remarks
		GBR-P	GBR-B	GBR-C	GBR-P	GBR-B	GBR-P	GBR-B	GBR-C	
6	Elongation	A	A	A	A	A	EN ISO 527-1 EN ISO 527-3 EN ISO 527-4 or EN 12311-2	EN 12311-1	EN ISO 10319	For GBR-P use EN ISO 527-1 and EN ISO 527-3, test specimen type 5 at a speed of 100 mm/min. For reinforced GBR-P use EN ISO 527-1 and EN ISO 527-4:1997, specimen type 2, width 50 mm, at a speed of 5 mm/min. Calculation of elongation as defined in EN ISO 527-1:2012, 10.2, using grip separation measurement. EN 12311-2 should only be used for non-polyolefinic GBR-P.
7	Static puncture	H	H	H	H	H	EN ISO 12236	EN ISO 12236	EN ISO 12236	
8	Burst strength	S	S	S	S	S	EN 14151	EN 14151	EN 14151	This test applies to GBR-C only if they contain a polymeric or bituminous barrier element.
9	Tear strength	S	S	-	S	S	ISO 34-1	EN 12310-1	-	For GBR-P use ISO 34-1:2010 method B, angle specimen (Figure 2) without nick at a speed of 50 mm/min.
10	Friction direct shear	S	S	S	-	-	EN ISO 12957-1	EN ISO 12957-1	EN ISO 12957-1	
11	Friction inclined plane	S	S	S	-	-	EN ISO 12957-2	EN ISO 12957-2	EN ISO 12957-2	
	Thermal properties									
12	Low temp behaviour (flexure)	S	S	-	S	S	EN 495-5	EN 1109	-	
13	Thermal expansion	A	-	-	A	-	ASTM D696	-	-	

Table 1 (continued)

Nr	Property to be tested	Covered in service			Not covered in service		Test methods			Remarks
		GBR-P	GBR-B	GBR-C	GBR-P	GBR-B	GBR-P	GBR-B	GBR-C	
	Durability and chemical resistance									
14	Weathering	H	H	S	H	H	EN 12224	EN 12224	EN 12224	GBR-C: see 4.4.6.
15	Micro organisms	A	A	A	A	A	EN 12225	EN 12225	EN 12225	
16	Oxidation	H	H	H	H	H	EN 14575	EN 14575	EN ISO 13438	EN ISO 13438 is applicable for the geotextile elements and reinforcement yarns of GBR-C barriers.
17	Environmental stress cracking	H	-	H	H	-	EN 14576		EN 14576	<p>EN 14576 is not applicable to GBR-P with a non-crystalline structure.</p> <p>If GBR-P is greater 0,5 mm and less than 1,0 mm the test EN 14576 shall be performed with the same composition at a thickness between 1,0 mm and 1,5 mm.</p> <p>In order to estimate exposure durability of thermoset elastomers, as non-crystalline materials cannot be tested following the environmental stress cracking test (EN 14576), the ozone stress cracking test shall be performed according to EN 1844 and evaluated with tensile strength measurements of the reference and the exposed specimen in accordance with B.4.1.</p>

Table 1 (continued)

Nr	Property to be tested	Covered in service			Not covered in service		Test methods			Remarks
		GBR-P	GBR-B	GBR-C	GBR-P	GBR-B	GBR-P	GBR-B	GBR-C	
18	Chemical resistance	S	S	S			EN 14414	EN 14414	ASTM D6141	
19	Leaching (water soluble)	A	A	A	A	A	EN 14415	EN 14415	EN 14415	
20	Wetting/drying	-	-	S	-	-	-	-	CEN/TS 14417	
21	Freezing/thawing	-	-	S	-	-	-	-	CEN/TS 14418	
22	Root penetration	S	S	S	S	S	CEN/TS 14416	CEN/TS 14416	CEN/TS 14416	
Relevancy: H: required for harmonisation; A : relevant to all conditions of use; S : relevant to specific conditions of use; -: not relevant										

Particular application cases may contain requirements about additional properties and - preferably standardised - test methods, if they are technically relevant and not conflicting with European Standards. The design life of the product should be determined, since its function may be temporary, as a construction expediency, or permanent, for the lifetime of the structure.

4.4 Characteristics relevant to specific conditions of use

4.4.1 General

The specification shall define which functions and conditions of use are relevant (see Table 1). The producer of the product shall provide the necessary data based on the requirements and test methods described in this document.

The list of characteristics in Table 1 includes those required for harmonisation (H), those relevant to all conditions of use (A), and those relevant to specific conditions of use (S). These specific conditions of use are listed in 4.4.2 to 4.4.10.

4.4.2 Tear strength

Data on the tear strength of polymeric and bituminous barriers are required when they are laid on slopes or inclined surfaces or otherwise exposed to mechanical stress.

4.4.3 Burst strength

Data on the burst strength are required in all applications where multi-axial deformation of geosynthetic barriers can occur as a result of settlement, deformation in designed or accidental situations.

4.4.4 Friction characteristics (direct shear and inclined plane tests)

Data on friction characteristics are required in all applications where differential movement may take place between the product and adjacent materials including, but not by way of limitation, geosynthetic barriers applied to slopes and certain types of anchoring arrangements.

In addition to the friction characteristics information on the internal bonding strength of GBR-C in the direction of the actual stress may be relevant. A shear (EN ISO 12957 and ASTM D6243) or peel (EN ISO 13426-1 and EN ISO 13426-2 and/or ASTM D6496 (for needle punched GBR-C)) test may be appropriate, particularly on slopes or in applications where shear stress may occur (i.e. during installation).

Site specific testing should be carried out to establish the friction characteristics between all the materials used.

4.4.5 Low temperature behaviour

Data on low temperature behaviour are required for applications where polymer and bituminous products may be exposed to low temperatures in storage, construction and use.

Tests which set simple pass/fail criteria at a single temperature condition may not be appropriate for this purpose.

Prehydrated GBR-C should not be stored or installed when the ambient temperature is below 0 °C.

4.4.6 Weathering

Data on weathering (combined effects of cycles of wetting, temperature change, and exposure to UV light) are required for applications where the GBR-C barrier will be exposed to weathering without adequate protective cover. It should be noted that in all normal situations GBR-C barriers should be covered with soil or other revetment on the same working day or prior to any circumstances which could cause a hydration of the clay component.

4.4.7 Resistance to wetting and drying

Data on the resistance of GBR-C to repeated wetting and drying is required when the conditions of use will subject the product to this sequence of actions.

4.4.8 Freeze-thaw cycle resistance

Data on the resistance of GBR-C to freeze/thaw is required when the conditions of use will subject the product to this sequence of actions.

4.4.9 Resistance to root penetration

Data on root penetration is required in all applications where the geosynthetic barrier is exposed to soils containing restorative vegetation.

4.4.10 Chemical resistance

This should be restricted to a consideration of the substrate on to which the material is laid and/or chemicals contained within the stored water.

4.5 Release of dangerous substances

National regulations on dangerous substances may require verification and declaration on release, and sometimes content, when construction products covered by this standard are placed on those markets.

In the absence of European harmonised test methods, verification and declaration on release/content should be done taking into account national provisions in the place of use.

NOTE An informative database covering European and national provisions on dangerous substances is available at the Construction web site on EUROPA accessed through: <http://ec.europa.eu/enterprise/construction/cpd-ds/>.

5 Evaluation of conformity

5.1 Presentation of characteristics

The characteristics specified in Table 2, except for durability, expressed as mean values and tolerance limit(s) corresponding to the 95 % confidence level, shall be given by the manufacturer, based on the statistical interpretation of his internal quality control measurements.

Physical examination or preliminary testing, according to one of the test methods referenced in Table 1, may indicate that values obtained for a product lie below (or above) the sensitivity threshold established for that test method. In these particular circumstances the manufacturer may declare a value as being less (or greater) than this sensitivity threshold value.

Information about durability shall be expressed in accordance with Annex B.

5.2 Verification of values

The marking and labelling of the rolls and of the products shall be checked. The marking of the products shall be according to EN ISO 10320.

NOTE The method described in this clause is not compulsory for an on-site control procedure.

The compliance of characteristics with the values defined in 5.1 shall be based on measurements made on two representative samples (A and B), taken from two different rolls. Sampling shall be made in accordance with EN ISO 9862.

The characteristics given in Table 2 shall be measured in accordance with the corresponding European Standards on specimens prepared from sample A.

If the test result(s) for a particular characteristic is (are) within the tolerance limit(s) given by the manufacturer, the product is accepted as complying with respect to this characteristic.

If the test result(s) for a particular characteristic is (are) outside the tolerance limit(s), specimens prepared from sample B shall be tested.

If the test result(s) of the sample B specimens for the same characteristic are within the given tolerance limit(s), the product is accepted as complying with respect to that characteristic. If the test result(s) is (are) outside the tolerance limit(s), the product is not accepted.

5.3 Initial type tests

Initial type tests shall be carried out by the manufacturer to define the values of the properties to be declared for the product to satisfy the requirements of this document.

Initial type tests shall also be carried out on existing products when a change in the basic materials or manufacturing procedures affects the declared properties or the use of a product. In these cases the appropriate initial type tests are those for the properties which are affected or need confirming and new properties introduced by a change of use.

The tests to be conducted shall be reference tests as specified in this document. and shall be selected for the characteristics specified in Table 2, consistent with the product's intended use:

Table 2 — Characteristics required for initial type testing and evaluation of conformity

Characteristic ^a	Functions
Tensile strength	Fluid barrier
Static puncture (CBR test)	Fluid barrier
Liquid tightness	Fluid barrier
Durability	Fluid barrier
^a For the durability aspects of these characteristics, see Table 1, 4.4 and Annex B.	

The results of initial type tests shall be recorded and be available for inspection.

The sample for the type tests shall be drawn according to EN ISO 9862 from a normal production run using the materials and forming processes to be used for the full production process. The size of the sample shall be big enough to allow the determination of the characteristics specified in Table 2. Handmade samples, short trial batches and other development prototypes may be tested by the same methods, but shall not be used for establishing characteristic values in type tests.

5.4 Factory production control

A factory production control scheme shall be established and documented in a manual prior to a product type being placed on the market. Subsequently, any fundamental changes in raw materials and additives, manufacturing procedures or the control scheme that affects the properties or use of a product shall be recorded in the manual.

The manual shall include the factory production control procedures relevant to the declared properties, as confirmed by the initial type tests.

The factory production control procedures shall consist of a system for the permanent internal control of the production of the products to ensure that such products comply with this document and that the measured values conform with the declared values.

Annex A (normative) lists all the items that shall be considered to determine which is appropriate for the control exercised for a product. The manufacturer shall establish the applicable items and record them in his factory production control manual.

When relevant, the procedure given in 5.2 shall be used to check the conformity of the product, for one or more of the characteristics.

5.5 Inspection

When required, inspection of the factory and of the factory production control shall be made on the provisions contained in 5.4 and Annex A.

6 Marking

The manufacturer shall clearly and indelibly mark the geosynthetic barrier with the information specified in EN ISO 10320.

NOTE For CE Marking, see ZA.3.

Annex A (normative)

Factory production control — Factory production control scheme

A.1 General

The items to be addressed in the factory production control manual relating to the system of control determined from 5.4 are given in this annex.

A.2 Product design

The manufacturer shall describe how design requirements and criteria are identified, checked, controlled and updated to be unambiguous and relevant to the use of the product and its specification.

The manufacturer shall describe the communication of the design to the internal production departments or external sub-contractors.

A.3 Production

A.3.1 Raw or incoming materials

The manufacturer shall define the acceptance criteria of incoming materials and the procedures that he operates to ensure that these are met.

A.3.2 Production process

The relevant features of the plant and production process shall be defined giving the frequency of the inspections, checks and tests, together with the values or criteria required both on equipment and on work in the process. The action to be taken when control values or criteria are not obtained shall be recorded. These records shall be available for inspection by relevant parties.

A.4 Finished products

A.4.1 Raw or incoming materials

The manufacturer shall define the acceptance criteria of incoming materials and the procedures that he operates to ensure that these are met. Table A.1 to Table A.3 specify testing frequencies for harmonised (mandatory) properties; for other purposes than CE-marking other frequencies may be appropriate.

Table A.1 — Polymeric GBRs

Property	Test method	Test frequency	Remarks
Water permeability	EN 14150	One per formulation but not less than one test per five years ^{a, b}	Test lowest manufactured thickness only
Tensile strength	EN ISO 527	One per production day	—
Static puncture	EN ISO 12236	One per production day	—
Weathering	EN 12224	One per formulation but not less than one per five years ^b	Test lowest manufactured thickness only
Oxidation	EN 14575	One per formulation but not less than one per five years ^b	Test lowest manufactured thickness only
Environmental stress cracking (Polyolefinic GBR-P only subject to requirements of B.3.4)	EN 14576	One per 1 000 t product or on change of formulation ^b	EN 14576 is not applicable to GBR-P with a non-crystalline structure
<p>^a For other purposes than CE-marking other frequencies may be appropriate. For instance, by increasing the frequency of the gas permeability test, consistency may support the existing frequency for water permeability test.</p> <p>^b "Formulation" includes specific raw material type/manufacturer, and type and proportion used of all additives or other components.</p>			
<p>NOTE Where a manufacturer operates more than one production line at the same manufacturing location the above testing frequencies mean "per production line".</p>			

Table A.2 — Bituminous GBRs

Property	Test method	Test frequency	Remarks
Water permeability	EN 14150	One per formulation but not less than one test per five years ^{a, b}	Test lowest manufactured thickness only
Tensile strength	EN 12311-1	One per production day	—
Static puncture	EN ISO 12236	One per production day	—
Weathering	EN 12224	One per formulation but not less than one per five years ^b	Test lowest manufactured thickness only
Oxidation	EN 14575	One per formulation but not less than one per five years ^b	Test lowest manufactured thickness only
^a For other purposes than CE-marking other frequencies may be appropriate. For instance, by increasing the frequency of the gas permeability test, consistency may support the existing frequency for water permeability test.			
^b "Formulation" includes specific raw material type/manufacturer and type and proportion used of all additives or other components.			
NOTE Where a manufacturer operates more than one production line at the same manufacturing location the above testing frequencies mean "per production line".			

Table A.3 — Clay GBRs

Property	Test method		Test Frequency
Water permeability	EN 16416		One per 25 000 m ² or on change of formulation ^{a b}
Tensile strength	EN ISO 10319		One per 20 000 m ² or on change of formulation ^b
Static puncture	EN ISO 12236		One per 50 000 m ² or on change of formulation ^b
Oxidation	EN ISO 13438	EN ISO 13438 is applicable for the geotextile elements and reinforcement yarns of GBR-C barriers	One per five years or on change of formulation ^b
^a For other purposes than CE-marking other frequencies may be appropriate. For instance, by increasing the frequency of the gas permeability test, consistency may support the existing frequency for water permeability test. ^b "Formulation" includes specific raw material type/manufacturer and type and proportion used of all additives or other components.			
NOTE Where a manufacturer operates more than one production line at the same manufacturing location the above testing frequencies mean "per production line".			

A.4.2 Alternative tests

Where alternative tests to the reference tests are used, details of the alternative tests and procedures together with their correlation with the reference tests shall be recorded and shall be made available upon request from a relevant party.

A.4.3 Equipment

Test equipment having a bearing on test results shall be calibrated to traceable national or International standards.

The manufacturer shall have or have available the installations, equipment and personnel which enable him to carry out the necessary verifications and tests. He may meet this requirement by concluding a subcontracting agreement with one or more organisations or persons having the necessary skills and equipment.

The manufacturer shall calibrate or verify and maintain the control, measuring or test equipment in good operating condition, whether or not it belongs to him.

The appropriate calibrations shall be carried out on defined measuring and test instruments according to standards or manufacturer's test procedures.

The equipment shall be used in conformity with the specification or the test reference system to which the specification refers.

A.4.4 Provisions applicable to A.2, A.3 and A.4 (to be used where appropriate)

A.4.4.1 Records

The dates, together with details and results of inspections, checks and tests carried out during the factory production control shall be properly recorded. These records shall be maintained for 10 years.

The product description, the date of manufacture, test method adopted, test results and acceptance or rejection criteria shall be entered under the signature of the person responsible for control who carried out the verification.

A.4.4.2 Assessment of results

Where possible and applicable, the results of inspections, checks and tests shall be interpreted statistically by attributes or by variables to determine whether the corresponding production conforms with the requirements and the declared values for the products.

A.4.4.3 Traceability

Systems of traceability and control of designs, incoming materials, and the use of materials shall be given in the manual. The stock control system of manufactured products shall be given in the manual.

A.4.4.4 Corrective action for non-conforming materials and products

The immediate actions to be taken when incoming materials or finished products do not conform to the requirements of this standard shall be described and recorded. These actions shall include the steps necessary to rectify the deficiency, modify the manual if required, identify and isolate the deficient raw or incoming materials and finished products and determine whether they shall be discarded or re-specified.

A.4.4.5 Personnel

The manufacturer shall ensure that the personnel involved in the process are suitably trained. The job description and responsibility of the operatives shall be given in the manual.

A.4.4.6 Quality management

The activities to ensure that all of the above requirements operate shall be described in the manual.

Annex B (normative)

Durability of geosynthetic barriers

B.1 Introduction

B.1.1 Standards to which this annex is common

This annex provides information on the durability tests, evaluation criteria and levels of acceptability to be carried out in accordance with the following standards (and with the test methods defined in Table 1 thereof):

EN 13361, *Geosynthetic barriers — Characteristics required for use in the construction of reservoirs and dams*

EN 13362, *Geosynthetic barriers — Characteristics required for use in the construction of canals*

EN 13491, *Geosynthetic barriers — Characteristics required for use in the construction of tunnels and underground structures*

EN 13492, *Geosynthetic barriers — Characteristics required for use in the construction of liquid waste disposal sites, transfer stations or secondary containment*

EN 13493, *Geosynthetic barriers — Characteristics required for use in the construction of solid waste storage and disposal sites*

EN 15382, *Geosynthetic barriers — Characteristics required for use in transportation infrastructure*

B.1.2 Mechanisms of degradation

The durability of a geosynthetic barrier depends on various mechanisms that cause degradation, i.e. reduction of mechanical or hydraulic performance. These mechanisms may be summarised as the following:

- a) oxidative attack accelerated by elevated temperature, exposure to UV light, or repetitive mechanical stress and possibly by chemicals, e.g. heavy metals;
- b) hydrolytic attack accelerated by elevated temperature, acid and alkaline conditions;
- c) solvation, i.e. change in physical properties due to absorption of liquid chemicals;
- d) environmental stress cracking, i.e. the mechanical failure of the geosynthetic barrier at stresses less than its yield strength in the presence of certain chemical species;
- e) microbiological attack which includes the action of bacteria and fungi, and penetration by plant roots;
- f) leaching of the soluble components of the geosynthetic barrier, thereby directly or indirectly affecting its mechanical properties or its resistance to other forms of degradation;
- g) in the case of PVC, by the loss of plasticizers followed by dehydrochlorination.

B.1.3 Service life

The provisions and the verification methods of the annex are based upon an indicative service life of 25 years for the intended use of a product as indicated in the scope of the standard, when installed in the works. This is under the condition that the product is correctly installed, used and maintained. These provisions are based upon the current state of the art and the knowledge and experience gained.

The service life is intended to be a conservative minimum. The real working life may turn out to be considerably longer under normal conditions of use without major degradation affecting the essential requirements. The service life shall not be interpreted as a guarantee given by the manufacturer, but regarded only as a means for choosing a product appropriate to the service conditions and the intended life of the works.

B.1.4 Use of rework materials

Rework material can be used without limitations, if the original raw material meets the requirements of this annex and no pelletizing is done in the rework process.

If pelletizing is done in the rework process, rework material can be used if the final product meets the requirements of this annex.

Pelletizing is a thermal process whereby the polymer melt coming from an extruder is pressed through a die plate and cut by knives to make pellets. This process may affect the properties of the product. If the original raw material meets the requirements of this annex, a maximum of 10 % pelletized rework material may be acceptable without further proof.

B.2 Test requirements

B.2.1 General requirement

Except where specifically exempted, all GBR shall satisfy the requirements in B.2.3 for initial type testing (ITT).

B.2.2 Requirements for repeat testing

A product that is unchanged shall be tested again after the maximum interval (minimum test frequency) as shown in Table A.1, Table A.2 and Table A.3. A product is regarded as unchanged if the raw material supply, the production technology and the process and stabilisation of the product have not been subject to a significant process change. If a product has been subject to a significant process change then it shall be tested in the same manner as for a new product.

A significant process change is defined as any of the following:

- a change in the chemical formulation (CAS No);
- reduced active ingredient concentration levels of raw materials in the polymer recipe;
- substitution of any polymer in the recipe with a replacement of the same chemical formulation from a different supplier, irrespective of any change in concentration.

Testing of a changed product may be exempted if the producer can demonstrate by means of regular assessment, including analyses of the process and long-term stabilisers, that the type of active ingredients has remained the same and that the content of these ingredients is no lower than that in the material used in the original ITT for durability.

B.2.3 Requirements for individual materials

B.2.3.1 Polyolefins

Polyolefin GBRs include HDPE, MDPE, LDPE, LLDPE, VLDPE, FPO and FPP. These can be reinforced or unreinforced, structured or smooth. The following test methods apply:

- weathering (B.3.2);
- resistance to leaching (B.3.5);
- resistance to oxidation (B.3.6);
- chemical resistance (B.3.7);
- environmental stress cracking (B.3.4): see paragraph below.

Evaluation and acceptance criteria shall be in accordance with B.4.2 and B.4.3. Both criteria shall be satisfied. Should tensile testing to B.4.2 not be feasible, for example for structured products without a smooth edge, then OIT (B.4.3) shall be used alone.

Testing for resistance to environmental stress cracking (B.3.4) does not apply to non-crystalline polymers (LDPE, LLDPE, VLDPE, FPO, FPP) nor to thin films less than 1 mm in thickness. For GBR with textured surfaces the test shall be performed on specimens taken from an adjacent area as specified in B.3.4.

B.2.3.2 Thermoset elastomers

Thermoset elastomers (e.g. EPDM) can be reinforced or unreinforced. The following test methods apply:

- weathering (B.3.2);
- resistance to leaching (B.3.5);
- resistance to oxidation (B.3.6);
- chemical resistance (B.3.7);
- ozone stress cracking test to EN 1844.

Evaluation and acceptance criteria shall be in accordance with B.4.2.

B.2.3.3 Coated fabrics

This clause applies to coated fabrics consisting of a fibrous reinforcement coated with HDPE or LDPE. For those coated with PVC-P coated see B.2.3.4.

The following test methods apply:

- weathering (B.3.2);
- resistance to leaching (B.3.5);
- resistance to oxidation (B.3.6);
- chemical resistance (B.3.7).

Evaluation and acceptance criteria shall be in accordance with B.4.2.

B.2.3.4 PVC-P

PVC-P GBR can be reinforced, unreinforced, geotextile backed, structured or smooth. The following test methods apply:

- weathering (B.3.2);
- soil burial (B.3.3);
- resistance to leaching (B.3.5);
- resistance to oxidation (B.3.6).

Evaluation and acceptance criteria shall be in accordance with B.4.4 (loss of mass), although the tensile properties (B.4.2) may be used where appropriate.

B.2.3.5 Clay geosynthetic barriers (GBR-C)

Because GBR-C have to be covered within one day after installation weathering tests are not required.

The geotextile components shall satisfy the requirements of Annex B common to EN 13249, EN 13257 and EN 13265 for a duration of 25 years. The GBR component alone shall be tested for chemical resistance (B.3.7) and evaluated according to B.4.2 and B.4.3.

B.2.3.6 Bituminous geosynthetic barriers (GBR-B)

No specific tests apply to GBR-B. Should any durability test be required, then it shall be evaluated by means of B.4.5.

B.3 Durability tests

B.3.1 Introduction

All testing to establish the durability of geosynthetic barriers is carried out by first exposing a specimen to simulated and/or accelerated environments under controlled conditions (the exposure test) followed by one or more tests of selected physical/mechanical tests on the exposed specimen (the evaluation test). A comparison of the evaluation test results with those obtained from the same test on an unexposed control sample provides a basis for acceptability. The only exception to this rule is the test for resistance to environmental stress cracking which includes both exposure and evaluation in a single procedure.

Specimens for evaluation testing shall in all cases be cut from the exposed test plate after exposure.

In cases where a particular geosynthetic barrier is manufactured in a variety of grades that differ only from one another in their thickness, then it will be acceptable only to test the grade with the least thickness. However if subsequently a thicker grade is selected in order to meet the recommended level of durability performance in the relevant test then that thickness grade shall also be tested.

B.3.2 Weathering

B.3.2.1 General

Weathering is the degradation of a geosynthetic barrier exposed to the atmosphere under natural conditions of sunlight, precipitation, etc. It is photo-oxidative in nature and the principal stimulant is the ultraviolet radiation. Tests that provide a measure of the durability of a geosynthetic barrier exposed to weathering can be direct or indirect in their relationship to the weathering process.

B.3.2.2 Direct tests and accelerated tests

Two types of direct test are used in practice. Real time exposure tests are used to determine the effects of UV light on various construction materials. These tests may provide useful information on the degradation of the exposed materials but have the disadvantage of extended testing periods, in uncontrolled and variable conditions. Such data may not be representative.

The alternative testing approach is to use an accelerated method. This typically involves a controlled environment in which specimens are exposed to alternative periods of ultraviolet light and spraying with water. Such a test is described in EN 12224.

The principal variables in this type of test are the following:

- wavelength and energy emitted by the lamps;
- temperature of the specimen surface (typically 50 °C to 75 °C at black standard temperature);
- frequency of the UV exposure/water spray cycle;
- total time of UV exposure and the total test time.

All of the foregoing factors affect the results obtained and are defined in EN 12224.

The relationship between exposure time under test method EN 12224 and the real time exposure to sunlight in a particular location is an important consideration in the evaluation of test results. The countries of southern Europe experience an annual total radiant exposure of 3 GJ/m² to 6 GJ/m². A mean value of 4,5 GJ/m² is assumed. The UV radiant exposure (radiation with wavelength < 400 nm) is 6 % to 9 % of this or 350 MJ/m² per annum.

The radiant exposure in EN 12224 is limited to 50 MJ/m², corresponding to only about one summer month in southern Europe. Since the test irradiance is about 40 W/m² and should be interrupted for one hour in six, the standard test duration is approximately 430 h. To effectively simulate average European conditions on site for a period of one year the required test period should be 3 000 h.

Comparison between accelerated and natural weathering based on radiant exposure has been shown to be broadly correct, although the error in individual cases can exceed 50 %. Temperature, altitude, humidity and the equipment used in real time tests have a significant effect on the correlation.

B.3.2.3 Period of exposure

In consideration of the six required characteristics standards listed above (see B.1.1), three categories of exposure can be identified. These are:

- Applications where there is either no exposure of the geosynthetic barrier material to sunlight or where the material will be covered within three days of deployment. It is assumed that such material of limited resistance to weathering will be suitably protected for transportation with a UV resistant packaging foil and such protection will not be removed other than at the point of application. Such applications would include the lining of tunnels and other underground structures. No weathering test is required for these applications.
- Applications where there will be limited exposure of the geosynthetic barrier material during construction for a maximum period of one year but the design will require fill or covering materials to be provided so that there is no exposure in normal use for the life of the facility. Such applications would be the lining of solid waste landfills and some reservoirs, dams, and canals. For all GBR-P which rely on carbon black for their UV resistance and which are intended for exposed storage, it will be useful to show that the formulation includes carbon black 2 % – 3 % (ASTM D1603 or ASTM D4218 (muffle furnace)) and has a carbon black dispersion in CAT 1 or 2 according to ASTM D5596 or conduct a thermo gravimetric analysis according to EN ISO 11358. For these applications, see B.3.2.4.

- Applications where the geosynthetic barrier material will be exposed during normal operation throughout the lifetime of the structure (assumed to be 25 years). These applications include reservoirs, canals, dams, and liquid waste disposals where covering protection of the geosynthetic barrier is not prescribed by the design. For these applications, see B.3.2.5.

B.3.2.4 Requirements for periods of exposure up to one year

Specimens of GBR shall be tested to EN 12224 extended to a radiant exposure of 350 MJ/m², requiring an estimated exposure time of 3 000 h. The evaluation tests and acceptance criteria shall be as specified for the relevant material in B.2.3. The duration of testing shall be reported in the CE documentation.

B.3.2.5 Periods of exposure greater than one year

In the case of exposures on site of more than one year, the manufacturer shall provide a statement of the claimed duration to weathering of 25 years in the application. This shall be supported by a technical justification.

B.3.3 Resistance to micro-organisms

A sample of GBR shall be tested according to EN 12225. The evaluation tests and acceptance criteria shall be as specified for the relevant material in B.2.3.

Where a geosynthetic barrier is to be installed in soils where anaerobic or bio-enhanced conditions exist, an alternative test method should be considered.

B.3.4 Resistance to environmental stress cracking

A sample of GBR shall be tested in accordance with EN 14576 (Single Point Test, 30 % of tensile yield strength and 50 °C temperature). The acceptance criterion shall be a minimum duration of 336 h (2 weeks).

Specimens shall be taken in the weakest direction according to the measured tensile yield strength. Normally this will be the cross machine direction, i.e. the direction of the notch will be aligned with the machine direction.

The test report shall state whether any failure to achieve 336 h (2 weeks) is due to elongation without break: such failure shall be taken as meeting the requirements.

In the case of GBR-P with textured surfaces the test shall be performed on a specimen of the same material with smooth surfaces. Such specimens shall be taken from one of the following sources:

- smooth surface GBR-P at the pre-textured stage of manufacture (if applicable);
- on a specimen taken from any smooth surface welding selvedge provided at the edge of the roll.

B.3.5 Resistance to leaching

A sample of GBR shall be tested for its resistance to leaching by specified liquids in accordance with EN 14415 with the following modifications:

- Method A will be modified to 80 °C and 90 d, except for PVC-P;
- For PVC-P Method A will be modified to 70 °C and 180 d;
- Method C is only required for applications covered by EN 13492, EN 13493 and EN 15382.

The evaluation tests and acceptance criteria shall be as specified for the relevant material in B.2.3. In addition, any visible signs of degradation shall be reported.

B.3.6 Resistance to oxidation

A sample of GBR-P shall be tested for its resistance to oxidation according to EN ISO 13438:2004, Method C1. Alternatively, it shall be tested to EN 14575 modified as follows:

- for GBR-P and GBR-B: 85 °C and 90 d;
- for FPO, FPP and TPE: 80 °C and 90 d;
- for PVC-P: 80 °C and 120 d.

For GBR-B, where the testing temperature and testing time is not suitable to test the oxidation resistance of the bitumen, an alternative test method should be considered.

The evaluation tests and acceptance criteria shall be as specified for the relevant material in B.2.3.

GBR-P materials (B.2.3.1 to B.2.3.4) that are not subject to oxidation shall be tested for thermal degradation using this test, but evaluation will be limited to changes in properties in accordance with B.4.2.

B.3.7 Chemical resistance

B.3.7.1 All applications

A sample of GBR shall be tested in accordance with EN 14414:2004, procedures A and B (dilute acid and alkali).

The evaluation tests and acceptance criteria shall be as specified for the relevant material in B.2.3. In addition, any visible signs of degradation shall be reported.

B.3.7.2 Liquid and solid waste storage (EN 13492 and EN 13493)

A sample of GBR for use in the lining of liquid and solid waste storage facilities (EN 13492 and EN 13493) shall be tested in accordance with B.3.7.1 above and in addition in accordance with EN 14414:2004, procedure C (organic solvents) and procedure D (synthetic leachate).

The evaluation tests and acceptance criteria shall be as specified for the relevant material in B.2.3.

Site specific conditions may affect the durability of the GPR and the design life, this can be tested using site specific leachate according to EN 14414:2004, procedure E.

B.4 Evaluation tests and acceptance criteria

B.4.1 General

The properties for evaluation of the different GBR are defined in B.4.2 to B.4.5.

B.4.2 Evaluation by comparison of tensile properties

Specimens taken from exposed and unexposed samples shall be tested using the tensile test method appropriate to the geosynthetic barrier type as specified in Table 1 of this document. The acceptance criteria shall be retained values of at least 75 % of the original tensile strength and at least 75 % of the original elongation at break. Both criteria shall be satisfied. For GBR-C the acceptance criteria shall be at least 50 % retained strength (no criterion for elongation) and for thermoset elastomers (EPDM) at least 75 % retained strength and at least 60 % retained elongation at break. All tensile tests are to be performed in both directions. An in-plane reinforced product shall be tested diagonal to the mean reinforcement direction, providing that this

excludes the influence of the reinforcing fabric. If this is not feasible, then B.4.4 or B.4.5 may be used instead. Alternatively, the barrier layer may be separated from the fabric for durability testing.

B.4.3 Evaluation by comparison of Oxidative Induction Time (OIT) values

For GBR where tensile strength and elongation at break measurements are not sufficient for the evaluation of the durability, as they rely on additional stabiliser materials to provide resistance to oxidation, evaluation of the following tests will also be carried out on the basis of the comparison of the oxidative induction time (OIT) of an exposed specimen to that of an unexposed specimen.

A specimen taken from the exposed sample shall be tested to ISO 11357-6 (Standard OIT). The acceptance criterion is a retained OIT value of at least 55 % of the OIT value of an unexposed specimen. Alternatively, the High Pressure OIT (HP-OIT) according to ASTM D5885 can be used. In this case, the retained HP-OIT value is at least 80 % of the HP-OIT value of an unexposed specimen.

B.4.4 Evaluation by change in mass

Specimens of GBR shall be evaluated by measurement of the loss of mass (after drying according to the appropriate test methods, e.g. before measuring the mass the samples have to be dried until the loss of mass no longer exceeds 0,1 %) of a single specimen according to EN ISO 9864, measured before and after exposure. The acceptance criterion is a minimum retained mass of 95 %, for PVC-P 90 %.

B.4.5 Evaluation by change in water permeability

GBR-P and GBR-B specimens shall be evaluated according to EN 14150; GBR-C according to EN 16416.

The ratio of the water permeability of the exposed sample to that of an unexposed sample shall not exceed 5.

NOTE For example, if the water permeability for GBR-B is $2 \times 10^{-7} \text{ m}^3/\text{m}^2/\text{d}$ the acceptable criteria is $1 \times 10^{-6} \text{ m}^3/\text{m}^2/\text{d}$.

Annex ZA (informative)

Clauses of this European Standard addressing the provisions of the EU Construction Products Directive

ZA.1 Scope and relevant characteristics

This European Standard and this annex have been prepared under Mandate M/107 “Geotextiles” amended by M386 and given to CEN by the European Commission and the European Free Trade Association.

The clauses of this European standard shown in this annex meet the requirements of the mandate given under the EU Construction Products Directive (89/106/EEC).

Compliance with these clauses confers a presumption of fitness of the geosynthetic barriers covered by this annex for the intended uses indicated herein; reference shall be made to the information accompanying the CE marking.

This annex establishes the conditions for the CE marking of the geosynthetic barriers intended for the uses indicated in Table ZA.1 and shows the relevant clauses applicable.

This annex has the same scope as the relevant part in Clause 1 of this standard related to the aspect covered by the mandate and is defined by Table ZA.1.

Table ZA.1 — Scope and relevant clauses

Product: geosynthetic barriers as covered in the scope of the standard			
Intended use(s): as fluid barriers for application in the construction of canals			
Essential characteristics	Requirement clauses in this standard	Mandated level(s) or class(es):	Notes (Units used for mean value and tolerances)
Tensile strength	4.3, Table 1 (5)-Tensile strength	none	GBR-P: N/mm ² GBR-B: N/mm ² GBR-C: kN/m
Resistance to static puncture	4.3, Table 1 (7)-Static puncture	none	all GBR: kN
Liquid tightness	4.3, Table 1 (3)- Water permeability	none	GBR-P: (m ³ × m ⁻² × d ⁻¹) GBR-B: (m ³ × m ⁻² × d ⁻¹) GBR-C: (m ³ × m ⁻² × s ⁻¹)
Durability	4.3, Table 1 (14)-Weathering (16)-Oxidation (17)-Environmental stress cracking	none	
Dangerous substances	4.5	none	

For some products, testing in only one direction may be applicable, in which case it should be clearly specified in the information accompanying the CE Marking.

NOTE The 95 % confidence level corresponds to the mean value minus (and/or plus) 1,0 tolerance value(s).

The requirement on a certain characteristic is not applicable in those Member States (MSs) where there are no regulatory requirements on that characteristic for the intended use of the product. In this case, manufacturers placing their products on the market of these MSs are not obliged to determine nor declare the performance of their products with regard to this characteristic and the option “No performance determined” (NPD) in the information accompanying the CE marking (see ZA.3) may be used. The NPD option may not be used, however, where the characteristic is subject to a threshold level.

ZA.2 Procedure for attestation of conformity of geosynthetic barriers

ZA.2.1 System of attestation of conformity

The system of attestation of conformity of the geosynthetic barriers indicated in Table ZA.1, established by EC Decision 96/581/EC of 24 June 1996 published in the OJ as document L 254 as given in Annex III of the mandate for Geotextiles, is shown in Table ZA.2 for the indicated intended uses and relevant level(s) or class(es).

Table ZA.2 — System of attestation of conformity

Product(s)	Intended uses	Level(s) or class(es)	Attestation of conformity systems
Geosynthetics (membranes and textiles), geotextiles, geocomposites, geogrids, geomembranes and geonets used: <ul style="list-style-type: none"> - as fluid or gas barriers - as protective layer - for drainage and/or filtration - for reinforcement 	In roads, railways, foundations and walls, drainage systems, erosion control, reservoirs and dams, canals, tunnels and underground structures, liquid waste disposal or containment, for solid waste storage or waste disposal	-	2+
System 2+: See Directive 89/106/EEC (CPD) Annex III.2.(ii), First possibility, including certification of the factory production control by an approved body on the basis of initial inspection of factory and of factory production control as well as of continuous surveillance, assessment and approval of factory production control.			

The attestation of conformity of the geosynthetic barrier in Table ZA.1 shall be according to the evaluation of conformity procedures indicated in Table ZA.3 resulting from application of the clauses of this or other European Standard indicated therein.

Table ZA.3 — Assignment of evaluation of conformity tasks (for geosynthetic barriers under system 2+)

Tasks		Content of the task	Clauses to apply
Tasks for the manufacturer	Factory production control (FPC)	Parameters related to all characteristics of Table ZA.1	5.2, 5.4 and Annex A
	Initial type testing	All characteristics of Table ZA.1	5.1, 5.2, 5.3
	Further testing of samples	All characteristics of Table ZA.1	5.4
Tasks for the notified body	Certification of FPC on the basis of:	- initial inspection of factory and of FPC	5.4 and Annex A
		-continuous surveillance, assessment and approval of FPC	

ZA.2.2 EC Certificate and Declaration of Conformity

When compliance with the conditions of this annex is achieved, and once the notified body has drawn up the FPC certificate mentioned below, the manufacturer or his agent established in the EEA shall draw up and retain the EC Declaration of Conformity, which entitles the manufacturer to affix the CE marking. This EC Declaration of Conformity shall include:

- name and address of the manufacturer, or his authorised representative established in the EEA, and the place of production;

NOTE 1 The manufacturer may also be the person responsible for placing the product onto the EEA market, if he takes responsibility for CE marking.

- description of the product (type, identification, use, ...), and a copy of the information accompanying the CE marking;

NOTE 2 Where some of the information required for the declaration is already given in the CE marking information, it does not need to be repeated.

- provisions to which the product conforms (i.e. Annex ZA of this EN), and a reference to the ITT report(s) and factory production control records (if appropriate);
- particular conditions applicable to the use of the product (e.g. provisions for use under certain conditions);
- the number of the accompanying factory production control certificate, and FPC records, where applicable;
- name of, and position held by, the person empowered to sign the declaration on behalf of the manufacturer or his authorised representative.

The EC Declaration of Conformity shall be accompanied by the FPC certificate, drawn up by the notified body, which shall contain, in addition to the information above, the following:

- name and address of the notified body;

- the number of the factory production control certificate;
- conditions of validity of the certificate, where applicable;
- name of, and position held by, the person empowered to sign the certificate.

The above mentioned EC Declaration of Conformity or the EC Certificate of Conformity shall be presented in the language or languages accepted in the Member State in which the product is to be used.

ZA.3 CE marking and labelling

The manufacturer or his authorised representative established within the EEA (EU and EFTA) is responsible for the affixing of the CE marking.

The CE marking symbol to affix shall be in accordance with Directive 93/68/EEC and shall be accompanied by the following information:

- identification number of the certification body;
- name or identifying mark of the producer;
- registered address of the producer;
- the last two digits in which the marking is affixed;
- number of the certificate of factory production control;
- reference to this annex and this European Standard;
- information on the mandated characteristics: values to declare presented as indicated in 5.1 of this standard.

The purpose of this information is to identify the legal entity responsible for the manufacture of the product.

The affixing will be done on the packaging of the geosynthetic barriers in the way indicated in Figure ZA.1. The complete information will be given on the accompanying documents in the way presented in Figure ZA.2.

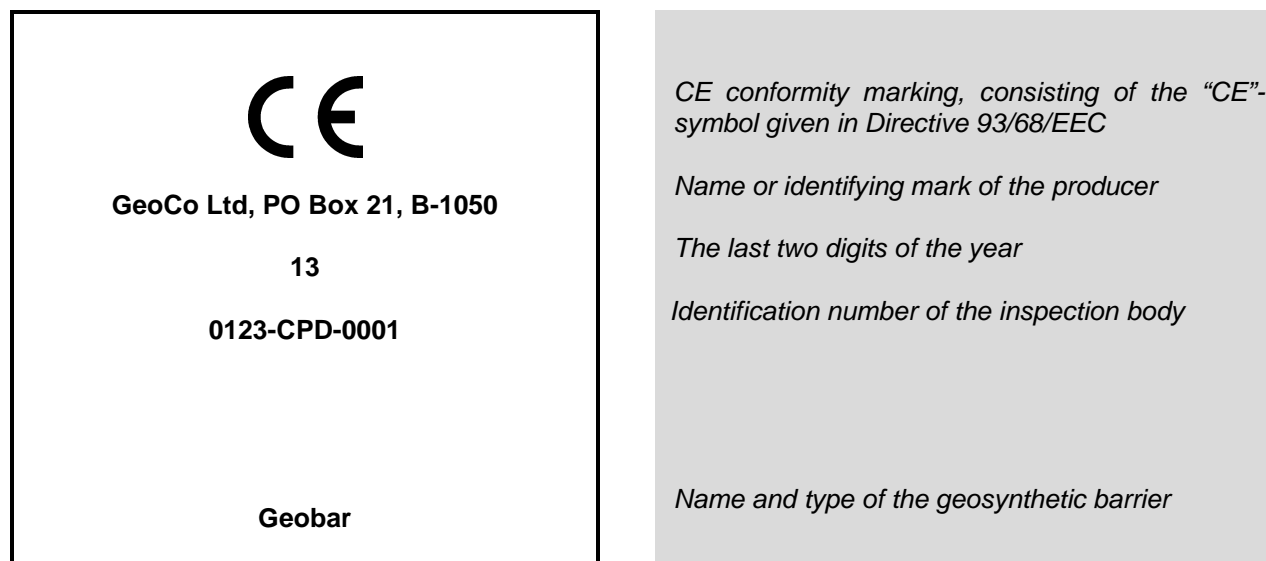



Figure ZA.1 — Example of CE marking on the packaging of a geosynthetic barrier

 0123-CPD-0001 Geobar
GeoCo Ltd, PO Box 21, B-1050 13 0123-CPD-0456 EN 13362 Polymeric geosynthetic barrier for use in canals Intended use: fluid barrier Tensile strength (EN ISO 527): MD 12 N/mm ² (-1 N/mm ²) CMD 10 N/mm ² (-0,8 N/m ²) Resistance to static puncture (EN ISO 12236): 1,2 kN (-0,1 kN) Water permeability (liquid tightness) (EN 14150) 4 x 10 ⁻⁶ m ³ /m ² x d Durability:

CE conformity marking, consisting of the “CE”-symbol given in directive 93/68/EEC.

Identification number of the inspection body

Name and type of the geosynthetic barrier

Name or identifying mark and registered address of the producer

Last two digits of the year in which the marking was affixed

Number of the FPC certificate

No. of applicable European Standard(s) with date of version

Identification of product, including type (polymeric, bituminous, clay)

Intended use (s)

and

Information on regulated characteristics

Example with values – average and tolerance value

Declaration on durability based on the provisions of Annex B

Figure ZA.2 — Example of accompanying documents

In the case of several standards being applicable for the CE marking of the same product, the accompanying document should refer to both standards and to the intended uses specified in their scopes.

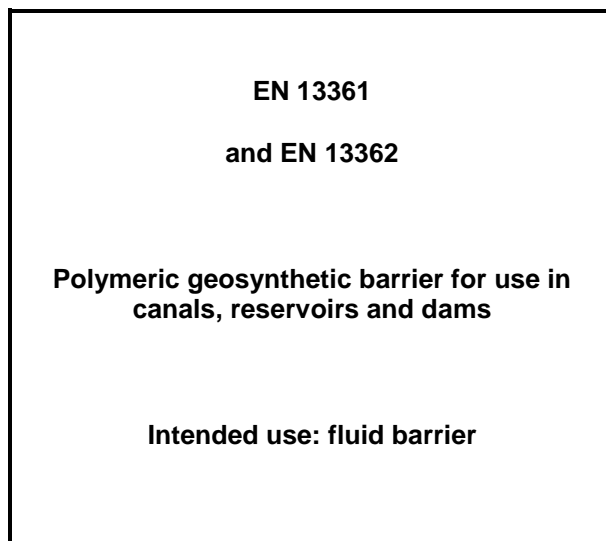

Intended use(s) of synthetic barriers in canals: as a barrier to the movement of fluids.

If required, in the Table ZA.1 the tolerance value(s) corresponding to the 95 % confidence level should be given by the manufacturer as follows:

Tensile strength	– α N/mm ² (GBR-P and GBR-B)	<i>example: (– 1 N/mm²)</i>
	– α kN/m (GBR-C)	<i>example: (– 1 kN/m)</i>
Resistance to static puncture	– α kN	<i>example: (– 0,15 kN)</i>
Water permeability	– α m ³ x m ⁻² x d ⁻¹ (GBR-P and GBR-B)	<i>example: (– 10⁻⁶ m³/m²/d)</i>
	– α m ³ x m ⁻² x s ⁻¹ (GBR-C)	<i>example: (– 10⁻¹⁰ m³/m²/s)</i>

Bibliography

- [1] M/107 — Mandate to CEN/CENELEC concerning the execution of standardisation work for harmonised standards on geotextiles — European Commission — 1996
- [2] European Directive 98/83/EC (3/11/98) on the quality of water intended for human consumption
- [3] EN 806-1:2000, *Specifications for installations inside buildings conveying water for human consumption — Part 1: General*
- [4] ISO/TS 13434, *Geosynthetics — Guidelines for the assessment of durability*
- [5] ASTM D5885, *Standard test method for oxidative induction time of polyolefin geosynthetics by high pressure differential scanning calorimetry*
- [6] ASTM D1603, *Standard test method for carbon black content in olefin plastics*
- [7] ASTM D4218, *Standard test method for determination of carbon black content in polyethylene compounds by the muffle-furnace technique*
- [8] ASTM D5596, *Standard test method for microscopic evaluation of the dispersion of carbon black in polyolefin geosynthetics*

British Standards Institution (BSI)

BSI is the national body responsible for preparing British Standards and other standards-related publications, information and services.

BSI is incorporated by Royal Charter. British Standards and other standardization products are published by BSI Standards Limited.

About us

We bring together business, industry, government, consumers, innovators and others to shape their combined experience and expertise into standards-based solutions.

The knowledge embodied in our standards has been carefully assembled in a dependable format and refined through our open consultation process. Organizations of all sizes and across all sectors choose standards to help them achieve their goals.

Information on standards

We can provide you with the knowledge that your organization needs to succeed. Find out more about British Standards by visiting our website at bsigroup.com/standards or contacting our Customer Services team or Knowledge Centre.

Buying standards

You can buy and download PDF versions of BSI publications, including British and adopted European and international standards, through our website at bsigroup.com/shop, where hard copies can also be purchased.

If you need international and foreign standards from other Standards Development Organizations, hard copies can be ordered from our Customer Services team.

Subscriptions

Our range of subscription services are designed to make using standards easier for you. For further information on our subscription products go to bsigroup.com/subscriptions.

With **British Standards Online (BSOL)** you'll have instant access to over 55,000 British and adopted European and international standards from your desktop. It's available 24/7 and is refreshed daily so you'll always be up to date.

You can keep in touch with standards developments and receive substantial discounts on the purchase price of standards, both in single copy and subscription format, by becoming a **BSI Subscribing Member**.

PLUS is an updating service exclusive to BSI Subscribing Members. You will automatically receive the latest hard copy of your standards when they're revised or replaced.

To find out more about becoming a BSI Subscribing Member and the benefits of membership, please visit bsigroup.com/shop.

With a **Multi-User Network Licence (MUNL)** you are able to host standards publications on your intranet. Licences can cover as few or as many users as you wish. With updates supplied as soon as they're available, you can be sure your documentation is current. For further information, email bsmusales@bsigroup.com.

BSI Group Headquarters

389 Chiswick High Road London W4 4AL UK

Revisions

Our British Standards and other publications are updated by amendment or revision.

We continually improve the quality of our products and services to benefit your business. If you find an inaccuracy or ambiguity within a British Standard or other BSI publication please inform the Knowledge Centre.

Copyright

All the data, software and documentation set out in all British Standards and other BSI publications are the property of and copyrighted by BSI, or some person or entity that owns copyright in the information used (such as the international standardization bodies) and has formally licensed such information to BSI for commercial publication and use. Except as permitted under the Copyright, Designs and Patents Act 1988 no extract may be reproduced, stored in a retrieval system or transmitted in any form or by any means – electronic, photocopying, recording or otherwise – without prior written permission from BSI. Details and advice can be obtained from the Copyright & Licensing Department.

Useful Contacts:

Customer Services

Tel: +44 845 086 9001

Email (orders): orders@bsigroup.com

Email (enquiries): cservices@bsigroup.com

Subscriptions

Tel: +44 845 086 9001

Email: subscriptions@bsigroup.com

Knowledge Centre

Tel: +44 20 8996 7004

Email: knowledgecentre@bsigroup.com

Copyright & Licensing

Tel: +44 20 8996 7070

Email: copyright@bsigroup.com



...making excellence a habit.™