

Unbound and hydraulically bound mixtures —

Part 44: Test method for the determination of the alpha coefficient of vitrified blast furnace slag

The European Standard EN 13286-44:2003 has the status of a
British Standard

ICS 93.080.20

National foreword

This British Standard is the official English language version of EN 13286-44:2003.

The UK participation in its preparation was entrusted by Technical Committee B/510, Road materials, to Subcommittee B/510/4, Cementitious bound materials, which has the responsibility to:

- aid enquirers to understand the text;
- present to the responsible international/European committee any enquiries on the interpretation, or proposals for change, and keep the UK interests informed;
- monitor related international and European developments and promulgate them in the UK.

A list of organizations represented on this subcommittee can be obtained on request to its secretary.

Cross-references

The British Standards which implement international or European publications referred to in this document may be found in the *BSI Catalogue* under the section entitled “International Standards Correspondence Index”, or by using the “Search” facility of the *BSI Electronic Catalogue* or of British Standards Online.

This publication does not purport to include all the necessary provisions of a contract. Users are responsible for its correct application.

Compliance with a British Standard does not of itself confer immunity from legal obligations.

This British Standard was published under the authority of the Standards Policy and Strategy Committee on 21 May 2003

Summary of pages

This document comprises a front cover, an inside front cover, the EN title page, pages 2 to 9 and a back cover.

The BSI copyright date displayed in this document indicates when the document was last issued.

Amendments issued since publication

Amd. No.	Date	Comments

© BSI 21 May 2003

ISBN 0 580 41908 8

EUROPEAN STANDARD

EN 13286-44

NORME EUROPÉENNE

EUROPÄISCHE NORM

May 2003

ICS 93.080.20

English version

Unbound and hydraulically bound mixtures - Part 44: Test method for the determination of the alpha coefficient of vitrified blast furnace slag

Mélanges traités aux liants hydrauliques et graves non traitées - Partie 44: Méthode d'essai pour la détermination du coefficient alpha des laitiers de hauts-fourneaux vitrifiés

Ungebundene und hydraulisch gebundene Gemische - Teil 44: Prüfverfahren zur Bestimmung des Alpha-Koeffizienten von verglasten Hochofenschlacke

This European Standard was approved by CEN on 21 February 2003.

CEN members are bound to comply with the CEN/GENELEC Internal Regulations which stipulate the conditions for giving this European Standard the status of a national standard without any alteration. Up-to-date lists and bibliographical references concerning such national standards may be obtained on application to the Management Centre or to any CEN member.

This European Standard exists in three official versions (English, French, German). A version in any other language made by translation under the responsibility of a CEN member into its own language and notified to the Management Centre has the same status as the official versions.

CEN members are the national standards bodies of Austria, Belgium, Czech Republic, Denmark, Finland, France, Germany, Greece, Hungary, Iceland, Ireland, Italy, Luxembourg, Malta, Netherlands, Norway, Portugal, Slovakia, Spain, Sweden, Switzerland and United Kingdom.



EUROPEAN COMMITTEE FOR STANDARDIZATION
COMITÉ EUROPÉEN DE NORMALISATION
EUROPÄISCHES KOMITEE FÜR NORMUNG

Management Centre: rue de Stassart, 36 B-1050 Brussels

Contents

	page
Foreword	3
1 Scope	4
2 Normative references	4
3 Term and definition	4
4 Apparatus	5
4.1 Specific grinding equipment for friability measurement	5
4.2 Specific equipment for measuring the specific surface of vitrified blast furnace slag	5
4.3 General equipment	5
5 Sampling and preparation	5
5.1 Sampling	5
5.2 Preparation of test sample	5
6 Test procedure	6
6.1 Friability	6
6.2 Specific surface and density	7
7 Expression of results	7
8 Test report	7
Annex A (normative) Equipment for measuring the specific surface	8
Key	8
Bibliography	9

Foreword

This document (EN 13286-44:2003) has been prepared by Technical Committee CEN/TC 227 "Road materials", the secretariat of which is held by DIN.

This European Standard shall be given the status of a national standard, either by publication of an identical text or by endorsement, at the latest by November 2003, and conflicting national standards shall be withdrawn at the latest by November 2003.

This European Standard is one of a series of standards as listed below.

prEN 13286-1, *Unbound and hydraulically bound mixtures - Test methods - Part 1: Test methods for laboratory reference density and moisture content - Introduction and general requirements.*

prEN 13286-2, *Unbound and hydraulically bound mixtures - Test methods - Part 2: Test methods for laboratory reference density and moisture content - Proctor compaction.*

prEN 13286-3, *Unbound and hydraulically bound mixtures - Test methods - Part 3: Test methods for laboratory reference density and moisture content - Vibrocompression with controlled parameters.*

prEN 13286-4, *Unbound and hydraulically bound mixtures - Test methods - Part 4: Test methods for laboratory reference density and moisture content - Vibrating hammer.*

prEN 13286-5, *Unbound and hydraulically bound mixtures - Test methods - Part 5: Test methods for laboratory reference density and moisture content - Vibrating table.*

prEN 13286-7, *Unbound and hydraulically bound mixtures - Test methods - Part 7: Cyclic load triaxial test for unbound mixtures.*

prEN 13286-40, *Unbound and hydraulically bound mixtures - Part 40: Test method for the determination of the direct tensile strength of hydraulically bound mixtures.*

prEN 13286-41, *Unbound and hydraulically bound mixtures - Part 41: Test method for the determination of the compressive strength of hydraulically bound mixtures.*

prEN 13286-42, *Unbound and hydraulically bound mixtures - Part 42: Test method for the determination of the indirect tensile strength of test specimens.*

prEN 13286-43, *Unbound and hydraulically bound mixtures - Part 43: Test method for the determination of the modulus of elasticity of hydraulically bound mixtures.*

prEN 13286-44, *Unbound and hydraulically bound mixtures - Test methods - Part 44: Test methods for binder activity - Determination of alpha coefficient of vitrified blast furnace slag.*

prEN 13286-45, *Unbound and hydraulically bound mixtures - Test methods - Part 45: Test method for the determination of the workability period.*

prEN 13286-46, *Unbound and hydraulically bound mixtures - Part 46: Test method for the determination of the moisture condition value (MCV).*

prEN 13286-47, *Unbound and hydraulically bound mixtures - Test methods - Part 47: Test methods for the bearing capacity, California Bearing Ratio (CBR), Immediate Bearing Index (IBI) and linear swelling.*

prEN 13286-48, *Unbound and hydraulically bound mixtures - Part 48: Test method for the determination of degree of pulverisation.*

EN 13286-44:2003 (E)

prEN 13286-49, *Unbound and hydraulically bound mixtures - Methods for making test specimens - Part 49: Accelerated swelling test for soil treated by lime and/or hydraulic binder.*

prEN 13286-50, *Unbound and hydraulically bound mixtures - Part 50: Methods for making test specimens using proctor equipment or vibrating table compaction.*

prEN 13286-51, *Unbound and hydraulically bound mixtures - Part 51: Methods for making test specimens by vibrating hammer compaction*

prEN 13286-52, *Unbound and hydraulically bound mixtures - Methods for making test specimens - Part 52: Making specimens by vibro-compression.*

prEN 13286-53, *Unbound and hydraulically bound mixtures - Methods for making test specimens - Part 53: Making cylindrical specimens by axial compression.*

Annex A is normative.

According to the CEN/CENELEC Internal Regulations, the national standards organizations of the following countries are bound to implement this European Standard: Austria, Belgium, Czech Republic, Denmark, Finland, France, Germany, Greece, Hungary, Iceland, Ireland, Italy, Luxembourg, Malta, Netherlands, Norway, Portugal, Slovakia, Spain, Sweden, Switzerland and the United Kingdom.

1 Scope

This European Standard describes a test method for the determination of the alpha () coefficient of vitrified blast furnace slag.

This European Standard applies to vitrified blast furnace slag obtained by granulation or by pelletizing.

2 Normative references

This European Standard incorporates by dated or undated reference, provisions from other publications. These normative references are cited at the appropriate places in the text, and the publications are listed hereafter. For dated references, subsequent amendments to or revisions of any of these publications apply to this European Standard only when incorporated in it by amendment or revision. For undated references the latest edition of the publication referred to applies (including amendments).

EN 196-6, *Methods of testing cement - Determination of fineness.*

EN 932-1, *Tests for general properties of aggregates - Part 1: Methods for sampling.*

EN 1097-1, *Tests for mechanical and physical properties of aggregates - Part 1: Determination of the resistance to wear (micro-Deval).*

EN 1097-7, *Tests for mechanical and physical properties of aggregates - Part 7: Determination of the particle density of filler - Pycnometer method.*

3 Term and definition

For the purposes of this European Standard, the following term and definition apply.

3.1

alpha () coefficient

is the product of the specific surface of the natural elements of the slag smaller than 0,080 mm and the friability where the friability is the percentage of elements smaller than 0,080 mm obtained after grinding according to this European Standard

NOTE The coefficient characterises the reactivity of a fresh vitrified blast furnace slag used for road construction.

4 Apparatus

4.1 Specific grinding equipment for friability measurement

4.1.1 A system imparting a rotation about the horizontal axis of (50 ± 1) rev/min to the grinding cylinder throughout the duration of the test.

4.1.2 A system with a revolution counter which stops the rotation of the cylinder after 1 175 revolutions.

4.1.3 Three stainless steel grinding micro-Deval cylinders in accordance with EN 1097-1.

4.1.4 Beads of industrial porcelain, (19 ± 1) mm in diameter.

4.2 Specific equipment for measuring the specific surface of vitrified blast furnace slag

The equipment shall conform to EN 196-6 but with a pressure gauge conforming to annex A.

4.3 General equipment

4.3.1 Ventilated oven for drying at 110 ± 5 °C.

4.3.2 Scale to read masses of 2 500 g with an accuracy of 1 g.

4.3.3 Scale to read masses of 150 g with an accuracy of 0,005 g.

4.3.4 Sieve of 5 mm, with bottom pan.

4.3.5 Sieve with an aperture between 8 and 12,5 mm.

4.3.6 Sieve of 0,080 mm.

4.3.7 Riffle with an opening larger than 10 mm.

4.3.8 Stiff-bristled brush.

4.3.9 Soft-bristled brush.

5 Sampling and preparation

5.1 Sampling

The sample reduction operations shall be carried out in accordance with EN 932-1.

The mass of the test sample shall be between 2 kg and 2,5 kg.

5.2 Preparation of test sample

The test sample shall be dried in the oven to constant mass, then sieved at 5 mm. The crumbly elements larger than 5 mm shall be crushed through the sieve using the stiff-bristled brush. The oversize shall be discarded.

From the test sample, take three sub-samples of mass (500 ± 1) g.

Set aside the rest of the test sample to measure the specific surface of the elements smaller than 0,080 mm.

6 Test procedure

6.1 Friability

The value of the friability, F , in %, shall be calculated with the formula

$$F = 1,152F_0 - 2,038$$

where

F is the friability, expressed in percent (%);

F_0 is the elementary friability, expressed in percent (%).

NOTE 1 Previously, friability (F) was determined using porcelain cylinders. Now friability is determined using micro-Deval cylinders. This is known as elementary friability, F_0 . In order to convert F_0 to F , the above regression equation should be used.

Introduce a sub-sample into each of the three cylinders.

Then introduce into each cylinder (1,95 ± 0,01) kg of porcelain beads.

NOTE 2 Bead diameters can be checked quickly by running the beads over two parallel bars spaced 18 mm apart.

Close the cylinders hermetically.

Rotate the cylinders on their horizontal axis for 1 175 revolutions.

NOTE 3 Make sure the cylinders do not leak before stacking them in the grinder.

In order to separate the ground slag from the porcelain beads, empty the contents of each cylinder on to the sieve with an aperture between 8 mm and 12,5 mm placed on a sieve bottom pan. Using the soft-bristled brush, brush carefully inside each cylinder in order to recover all the fine elements.

Dry sieve the ground slag on the 0,080 mm sieve.

NOTE 4 If necessary, use a 0,5 mm sieve to facilitate the sieving.

Set aside the material passing 0,080 mm sieve which shall be used to determine the density in accordance with 6.2.

NOTE 5 In the case of samples of the same origin, a single determination of the density of the elements finer than 0,080 mm may be carried out.

Then complete the sieving on the 0,080 mm sieve by washing and oven-drying the oversize. Then dry sieve again and weigh the oversize to within 1 g. The elementary friability, F_0 , (or proportion of elements smaller than 0,080 mm) shall be obtained from the formula.

$$F_0 = \frac{m_0}{0,500} \cdot 100$$

where

F_0 is the elementary friability, expressed in percent (%);

m is the average mass of the oversize material from the three sub-samples, expressed in kilograms (kg).

The result shall be expressed as a percentage to one decimal place.

6.2 Specific surface and density

Using the rest of the test sample from 5.2, it shall be dry sieve over an 0,080 mm sieve. The specific surface, S , of the elements finer than 0,080 mm shall be measured according to EN 196-6 but with the equipment described in annex A.

Density determination for the requirements of EN 196-6 shall be carried out in accordance with EN 1097-7.

7 Expression of results

The coefficient of the vitrified blast furnace slag shall be determined by the product:

$$= S \cdot F / 1\,000$$

where

is the coefficient of the vitrified blast furnace slag;

S is the specific surface of the elements finer than 0,080 mm, expressed in square centimetres per gram (cm²/g);

F is the friability, expressed in percent (%).

8 Test report

The test report shall refer to this European standard and shall include the following information:

- a) identification of test sample;
- b) date of test;
- c) specific surface, S , of test sample;
- d) friability, F , of test sample;
- e) coefficient of test sample;
- f) remarks about the operation that does not comply to this European Standard;
- g) others remarks.

Annex A (normative)

Equipment for measuring the specific surface

The procedure for measuring the specific surface shall be the same as that used in EN 196-6 but with the following modifications to the apparatus. The manometer shall be replaced by a manometer specially adapted for slag fines according to Figure A.1.

All dimensions in millimetres

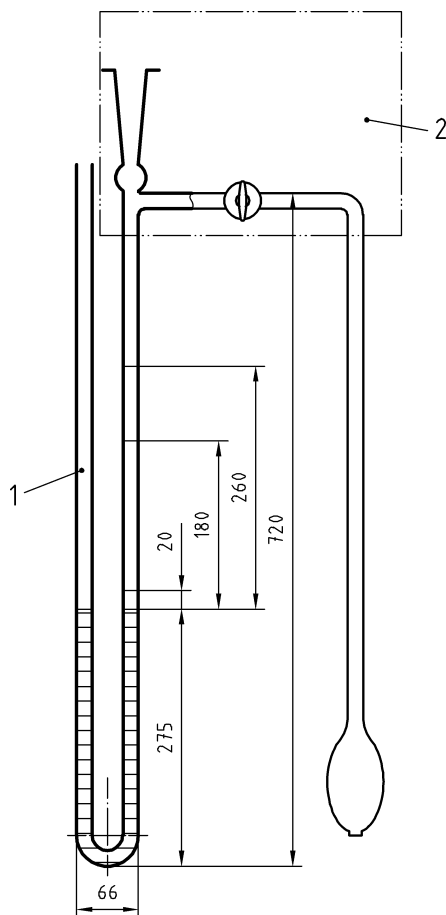

Key

- 1 Tube, 14,0 to 18,0
- 2 See EN 196-6

Figure A.1 — Manometer for measuring vitrified blast furnace slag fine elements (finer than 0,08 mm)

Bibliography

prEN 14227-2, *Unbound and hydraulically bound mixtures - Specifications - Part 2: Slag bound mixtures - Definitions, composition, classification.*

BSI — British Standards Institution

BSI is the independent national body responsible for preparing British Standards. It presents the UK view on standards in Europe and at the international level. It is incorporated by Royal Charter.

Revisions

British Standards are updated by amendment or revision. Users of British Standards should make sure that they possess the latest amendments or editions.

It is the constant aim of BSI to improve the quality of our products and services. We would be grateful if anyone finding an inaccuracy or ambiguity while using this British Standard would inform the Secretary of the technical committee responsible, the identity of which can be found on the inside front cover.
Tel: +44 (0)20 8996 9000. Fax: +44 (0)20 8996 7400.

BSI offers members an individual updating service called PLUS which ensures that subscribers automatically receive the latest editions of standards.

Buying standards

Orders for all BSI, international and foreign standards publications should be addressed to Customer Services. Tel: +44 (0)20 8996 9001.
Fax: +44 (0)20 8996 7001. Email: orders@bsi-global.com. Standards are also available from the BSI website at <http://www.bsi-global.com>.

In response to orders for international standards, it is BSI policy to supply the BSI implementation of those that have been published as British Standards, unless otherwise requested.

Information on standards

BSI provides a wide range of information on national, European and international standards through its Library and its Technical Help to Exporters Service. Various BSI electronic information services are also available which give details on all its products and services. Contact the Information Centre.
Tel: +44 (0)20 8996 7111. Fax: +44 (0)20 8996 7048. Email: info@bsi-global.com.

Subscribing members of BSI are kept up to date with standards developments and receive substantial discounts on the purchase price of standards. For details of these and other benefits contact Membership Administration.
Tel: +44 (0)20 8996 7002. Fax: +44 (0)20 8996 7001.
Email: membership@bsi-global.com.

Information regarding online access to British Standards via British Standards Online can be found at <http://www.bsi-global.com/bsonline>.

Further information about BSI is available on the BSI website at <http://www.bsi-global.com>.

Copyright

Copyright subsists in all BSI publications. BSI also holds the copyright, in the UK, of the publications of the international standardization bodies. Except as permitted under the Copyright, Designs and Patents Act 1988 no extract may be reproduced, stored in a retrieval system or transmitted in any form or by any means – electronic, photocopying, recording or otherwise – without prior written permission from BSI.

This does not preclude the free use, in the course of implementing the standard, of necessary details such as symbols, and size, type or grade designations. If these details are to be used for any other purpose than implementation then the prior written permission of BSI must be obtained.

Details and advice can be obtained from the Copyright & Licensing Manager.
Tel: +44 (0)20 8996 7070. Fax: +44 (0)20 8996 7553.
Email: copyright@bsi-global.com.