

Railway applications — Wheelsets and bogies — Wheelsets — Product requirements

ICS 45.040

National foreword

This British Standard is the UK implementation of EN 13260:2009. It supersedes BS EN 13260:2003 which is withdrawn.

The UK participation in its preparation was entrusted to Technical Committee RAE/3/-/1, Wheels and wheelsets.

A list of organizations represented on this committee can be obtained on request to its secretary.

This publication does not purport to include all the necessary provisions of a contract. Users are responsible for its correct application.

Compliance with a British Standard cannot confer immunity from legal obligations.

This British Standard was published under the authority of the Standards Policy and Strategy Committee on 30 April 2009

© BSI 2009

ISBN 978 0 580 57631 7

Amendments/corrigenda issued since publication

Date	Comments

EUROPEAN STANDARD

EN 13260

NORME EUROPÉENNE

EUROPÄISCHE NORM

March 2009

ICS 45.040

Supersedes EN 13260:2003

English Version

Railway applications - Wheelsets and bogies - Wheelsets - Product requirements

Applications ferroviaires - Essieux montés et bogies -
Essieux montés - Prescriptions pour le produit

Bahnanwendungen - Radsätze und Drehgestelle -
Radsätze - Produktanforderungen

This European Standard was approved by CEN on 26 December 2008.

CEN members are bound to comply with the CEN/CENELEC Internal Regulations which stipulate the conditions for giving this European Standard the status of a national standard without any alteration. Up-to-date lists and bibliographical references concerning such national standards may be obtained on application to the CEN Management Centre or to any CEN member.

This European Standard exists in three official versions (English, French, German). A version in any other language made by translation under the responsibility of a CEN member into its own language and notified to the CEN Management Centre has the same status as the official versions.

CEN members are the national standards bodies of Austria, Belgium, Bulgaria, Cyprus, Czech Republic, Denmark, Estonia, Finland, France, Germany, Greece, Hungary, Iceland, Ireland, Italy, Latvia, Lithuania, Luxembourg, Malta, Netherlands, Norway, Poland, Portugal, Romania, Slovakia, Slovenia, Spain, Sweden, Switzerland and United Kingdom.



EUROPEAN COMMITTEE FOR STANDARDIZATION
COMITÉ EUROPÉEN DE NORMALISATION
EUROPÄISCHES KOMITEE FÜR NORMUNG

Management Centre: Avenue Marnix 17, B-1000 Brussels

Contents

Page

Foreword.....	4
Introduction	5
1 Scope	6
2 Normative references	6
3 Product definition	6
3.1 Assembly of components	6
3.1.1 General.....	6
3.1.2 Interference between axle wheel seat and wheel hub bore	7
3.1.3 Press-fitting diagram	7
3.2 Wheelset characteristics.....	8
3.2.1 Mechanical resistance of the assemblies	8
3.2.2 Fatigue characteristics.....	8
3.2.3 Electrical resistance	9
3.2.4 Imbalance	9
3.2.5 Dimensions and tolerances	10
3.2.6 Residual stresses	14
3.2.7 Protection against corrosion and impacts.....	14
3.2.8 Marking	14
Annex A (normative) Characteristics of the press-fitting curve	16
Annex B (normative) Fatigue characteristics for a wheelset with an axle of steel grade EA1T or EA4T.....	18
Annex C (informative) Information on the test pieces for fatigue tests.....	19
Annex D (informative) Documents for the identification of wheelset components	21
Annex E (informative) Product qualification.....	25
E.1 General.....	25
E.2 Requirements	25
E.2.1 Requirements to be met by the supplier	25
E.2.2 Qualification of personnel	25
E.2.3 Requirements to be met by the product.....	26
E.3 Qualification procedure	26
E.3.1 General.....	26
E.3.2 Documentation required	26
E.3.3 Evaluation of the manufacturing plant and processes.....	26
E.3.4 Laboratory tests.....	27
E.3.5 Testing of finished products	27
E.4 Qualification certificate	27
E.4.1 Condition of validity	27
E.4.2 Modification and extension	27
E.4.3 Transference	28
E.4.4 Lapsed certification	28
E.4.5 Cancellation.....	28
E.5 Qualification file.....	28
Annex F (informative) Product delivery.....	29
F.1 General.....	29
F.2 Specific verifications	29
F.3 Optional checks	30
F.3.1 Dimensional check	30

F.3.2	Ultrasonic examination	30
F.4	Allowable rectification	30
F.5	Documents	31
F.5.1	Shrink-fitting	31
F.5.2	Press-fitting	31
F.5.3	Components	31
F.6	Quality plan	32
F.6.1	General	32
F.6.2	Objectives	32
F.6.3	Validity	32
Annex ZA	(informative) Relationship between this European Standard and the Essential Requirements of Council Directive 96/48/EC of 23 July 1996 on the interoperability of the trans-European high-speed rail system amended by Directive 2004/50/EC of 29 April 2004	33
Annex ZB	(informative) Relationship between this European Standard and the Essential Requirements of Directive 2001/16/EC of the European Parliament and of the Council of 19 March 2001 on the interoperability of the trans-European conventional rail system amended by Directive 2004/50/EC of 29 April 2004	34
Bibliography	36

Foreword

This document (EN 13260:2009) has been prepared by Technical Committee CEN/TC 256 "Railway applications", the secretariat of which is held by DIN.

This European Standard shall be given the status of a national standard, either by publication of an identical text or by endorsement, at the latest by September 2009, and conflicting national standards shall be withdrawn at the latest by September 2009.

Attention is drawn to the possibility that some of the elements of this document may be the subject of patent rights. CEN and/or CENELEC shall not be held responsible for identifying any or all such patent rights.

This document supersedes EN 13260:2003.

This European Standard has been prepared under a mandate given to CEN/CENELEC/ETSI by the European Commission and the European Free Trade Association, and supports essential requirements of EU Directives 96/48/EC and 2001/16/EC, amended by Directive 2004/50/EC.

For relationship with the EU Directives, see informative Annexes ZA and ZB, which are integral parts of this document.

According to the CEN/CENELEC Internal Regulations, the national standards organizations of the following countries are bound to implement this European Standard: Austria, Belgium, Bulgaria, Cyprus, Czech Republic, Denmark, Estonia, Finland, France, Germany, Greece, Hungary, Iceland, Ireland, Italy, Latvia, Lithuania, Luxembourg, Malta, Netherlands, Norway, Poland, Portugal, Romania, Slovakia, Slovenia, Spain, Sweden, Switzerland and the United Kingdom.

Introduction

The main purpose of normative documents used until now for the delivery of wheelsets (UIC leaflets, national standards) was a complete definition of the acceptance procedures and of the wheelset characteristics which were to be verified.

Product qualification was sometimes mentioned but the procedures used and the product characteristics to be verified during qualification were not given.

This standard addresses these points by:

- a) definition of all the wheelset characteristics that are assembly characteristics and finished product characteristics and do not arise from a choice of design parameters such as diameters, interferences, materials etc. They are verified during either qualification or delivery of the product (see clause 3);
- b) definition of qualification procedures (see Annex E);
- c) definition of delivery conditions (see Annex F). They are based on quality assurance concepts.

1 Scope

This European Standard specifies the characteristics of new wheelsets for use on European networks:

This standard is applicable to wheelsets comprising elements that conform to the following European Standards:

- EN 13262 for wheels;
- EN 13261 for axles;

This standard is not fully applicable to wheelsets undergoing maintenance.

Some characteristics are given as a function of a category 1 or of a category 2. Category 2 can be divided into sub-categories (2a and 2b) to specify certain characteristics. Category 1 is generally chosen when the operating speed exceeds 200 km/h. The wheelset then comprises wheels and axle of category 1 as specified in EN 13262 for the wheels and EN 13261 for the axles.

2 Normative references

The following referenced documents are indispensable for the application of this document. For dated references, only the edition cited applies. For undated references, the latest edition of the referenced document (including any amendments) applies.

EN 13103, *Railway applications – Wheelsets and bogies – Non-powered axles – Design method*

EN 13104, *Railway applications – Wheelsets and bogies – Powered axles – Design method*

EN 13261 *Railway applications – Wheelsets and bogies – Axles – Product requirements*

EN 13262 *Railway applications – Wheelsets and bogies – Wheels – Product requirements*

3 Product definition

3.1 Assembly of components

3.1.1 General

Before being assembled, all elements which comprise the wheelset shall meet the geometric requirements of the documents which define them. In particular, the wheels and the axle shall be in the "ready for assembly" state defined in EN 13262 for the wheels and EN 13261 for the axles.

The elements comprising the wheelset may be shrink-fitted or press-fitted.

The interferences to be used for fitting shall be defined by the designer of the element to be fitted and are a function of the characteristics of the element material and the forces and torque to be transmitted by the fitting. This interference shall be defined according to the geometric tolerances of the axle seats specified in EN 13261.

For the wheel fittings, unless otherwise specified by the wheel designer, the interference values to be used are given in 3.1.2.

In the case of shrink-fitting, the whole wheel should be heated and its temperature shall not exceed 250 °C. If a different heating method is used, proof shall be provided that there has been no effect on the wheel characteristics as defined in EN 13262.

If a different fitting method is used, this shall be the subject of an agreement between the customer and the supplier. In this agreement, the supplier shall demonstrate at least that the axle and wheel characteristics as defined in EN 13261 and EN 13262 are not modified by the fitting. Then, the mechanical resistance of the assembly (see 3.2.1) shall be demonstrated and the traceability documents for each fitting shall be defined so as to give the same type of information as specified in F.5.

The static imbalance of the two wheels of each wheelset shall be within the same diametric plane and on the same side of the axle. The static imbalance of the gear wheels and brake discs shall be in the same plane as those of the wheels, but on the opposite side of the axle.

3.1.2 Interference between axle wheel seat and wheel hub bore

Unless otherwise specified by the wheel designer, the interference values " j " to be adhered to are, in mm:

— for shrink-fitting: $0,0009 \text{ dm} \leq j \leq 0,0015 \text{ dm}$

— for press-fitting: $0,0010 \text{ dm} \leq j \leq 0,0015 \text{ dm} + 0,06$

where dm is the mean diameter in mm.

3.1.3 Press-fitting diagram

3.1.3.1 Results to be achieved

For press fitting, the force-displacement curve gives confidence that the fitting has not damaged the contact surfaces and that the specified interference has been effective.

The shape of the curve to be obtained is defined in Annex A.

The final fitting force, in MN, is a function of the force F defined in 3.2.1 and shall be within the range:

$$0,85 F < \text{final fitting force} < 1,45 F$$

3.1.3.2 Measurement method

The press used for the assemblies shall have a calibrated system to plot the diagram of the force value at each position of the element to be fitted, obtained during the displacement of the latter on the axle. The abscissa scale of displacement shall be at least equal to 0,5 times the actual displacement of the element to be fitted. The ordinate scale of force shall allow the force to be read at each point of the curve with an accuracy of 0,025 MN. The accuracy of the force sensor shall be 0,01 MN. The abscissae and ordinates may be reversed.

In the case of point recording, at least one point shall be plotted per millimetre of relative displacement of the elements to be fitted and per 0,025 MN variation in force.

3.2 Wheelset characteristics

3.2.1 Mechanical resistance of the assemblies

3.2.1.1 Results to be achieved

In order to be able to transmit forces and torques between the fitted elements, the assemblies shall be capable of withstanding an axial force F for 30 s without there being any displacement between one element and another.

This force F shall be defined by the designer of the element to be fitted.

For wheels, unless otherwise specified by the designer, the value of the force F in MN is:

$$F = 4 \cdot 10^{-3} dm$$

when $0,8 dm < L < 1,1 dm$

where dm is the mean diameter of the seat in mm and L is the length of the fitting in mm.

3.2.1.2 Test method

The test shall be carried out on a press equipped with a device to record forces.

The force is applied gradually up to F between one of the faces of the fitted component hub and the axle.

For press-fitted wheels, the test shall be carried out at least 48 h after fitting.

For shrink-fitted wheels, the test shall be carried out when the wheels and axle have returned to the same temperature after the fitting.

3.2.2 Fatigue characteristics

3.2.2.1 General

The rotational bending fatigue limit values for 10^7 cycles are defined here. These values are used to calculate the maximum permissible axle seat stresses and are required for application of EN 13103 and EN 13104.

These fatigue characteristics are not the same for a solid axle as for a hollow axle. This is the result of the axle bore effect on stress distribution.

For a solid axle, only one fatigue limit (F_3) shall be determined under the fitting areas.

For a hollow axle, given that the fitting effect is greater on the journals than on the other fitted areas because of the different metal thicknesses, two fatigue limits shall be considered:

- under the fitted parts, except for journals, limit F_4 ,
- under the fitted parts of the journal, limit F_5

NOTE 1 The fatigue limit F_4 is verified by testing during qualification. The fatigue limit F_5 can be calculated using the ratios $F_4/F_5 = 1,17$ and $F_3/F_5 = 1,276$

NOTE 2 The fatigue characteristic F_1 and F_2 of the axle are defined in EN 13261.

3.2.2.2 Values defined for EA1N

The minimum values for wheelsets using an axle of EA1N grade steel are given in Table 1.

Table 1 — Minimum values for wheelsets with an axle made of EA1N steel

Fatigue limit	F_3	F_4	F_5
N/mm ²	120	110	94

For other steel grades, the values are given in Annex B.

3.2.2.3 Fatigue test pieces

The area of the test piece where the crack initiates shall have geometry, environment and surface condition representative of the axle under consideration.

For the fatigue testing of the wheelsets, one wheel or test piece with similar dimensions (particularly the hub) shall be press-fitted or shrink-fitted on the wheel seat. The interference shall meet the requirements of 3.1.2.

It is not mandatory to use a wheelset as the test piece. An example of a test piece is given in Annex C.

3.2.2.4 Test method

The tests shall be carried out on machines capable of creating rotating bending stresses in the area where it is required to initiate a crack.

For each limit F_3 , and F_4 , it shall be verified on three test pieces that no crack has appeared after 10^7 cycles of a load creating a surface stress equal to F_3 or F_4 .

These stress levels shall be calculated on the seat, in accordance with the beam theory, disregarding the interference stresses.

3.2.3 Electrical resistance

The electrical resistance of each wheelset measured between the treads of the two wheels shall not exceed 0,01 Ω .

The means and method used for this measurement shall be defined in agreement between the customer and the supplier.

The test voltage shall be in the range 1,8 V – 2,0 V DC.

3.2.4 Imbalance

3.2.4.1 Values to be achieved

For a non-powered wheelset capable of running at a speed of greater than 120 km/h, a maximum dynamic imbalance shall be specified.

The maximum values are given in Table 2. They are measured in the plane of the wheels.

Table 2 — Maximum imbalance values

Speed (km/h)	Maximum imbalance x measuring plane (g.m)
$120 < V \leq 200$	75
$V > 200$	50

3.2.4.2 Test piece

The imbalance is measured on a fully assembled and machined wheelset.

3.2.4.3 Test method

The customer and the supplier shall agree the means of measurement.

3.2.5 Dimensions and tolerances

3.2.5.1 General

The dimensions of the wheelset shall be in accordance with the design drawings and the dimensional and geometric tolerances to be applied when assembling the different parts of the wheelset are given in the following subclauses.

They are dependent on the category of the wheelset.

The values are given for measurements taken with no load on the wheelset.

3.2.5.2 Wheels

The tolerances of the parameters defined in Figure 1 shall be those given in Table 3.

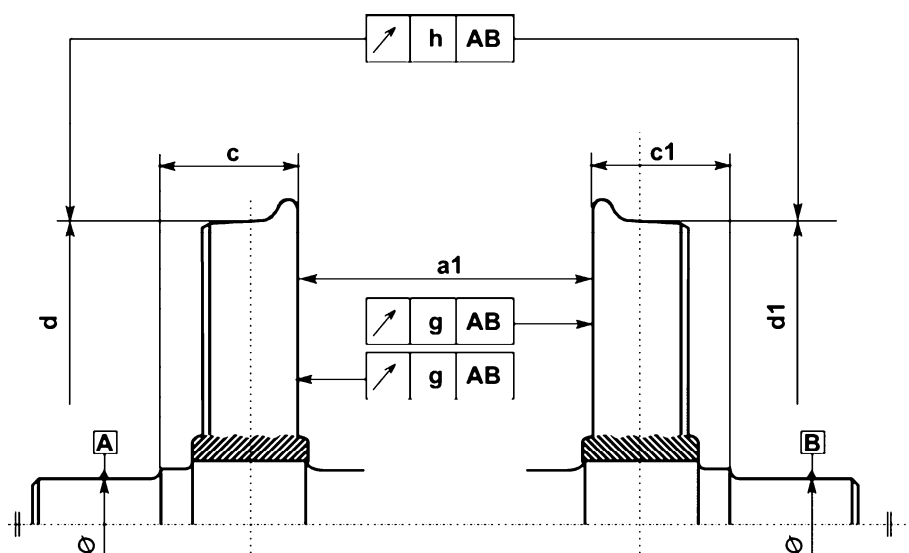

Figure 1 — Wheel parameters

Table 3 — Tolerances on wheel parameters

Dimensions in mm

Description	Symbol	Category 2		Category 1
		a	b	
Distance between the internal wheel faces ^a	a_1	$+2^b$ 0		$+2^b$ 0
Difference in distances between the internal face of each wheel and the plane on the journal side defining the corresponding collar bearing surface	$c - c_1$ or $c_1 - c$	≤ 1		≤ 1
Difference in tread circle diameter	$d - d_1$ or $d_1 - d$	$\leq 0,5$	$\leq 0,3$	$\leq 0,3$
Radial run-out in tread circle	h	$\leq 0,5$	$\leq 0,3$	$\leq 0,3$
Axial run-out of the internal wheel face ^a	g	$\leq 0,8$	$\leq 0,5$	$\leq 0,3$
^a Measurement at 60 mm beneath the top of the flange				
^b The tolerances may be changed for special designs of wheelsets				

3.2.5.3 Brake discs

3.2.5.3.1 General

The tolerances on the parameters defined in Figures 2 and 3 shall be those required in Tables 4, 5 and 6.

Table 4 — Axial run-out of the internal face

Dimensions in mm

Description	Symbol	Category 2 a	Category 2 b	Category 1
Axial run-out of the internal face ^a	g_1	$\leq 0,75$	$\leq 0,5$	$\leq 0,5$
^a See Figures 2 and 3. Measurements at 30 mm from the external diameter				

3.2.5.3.2 Single-seat axle for one or two brake discs

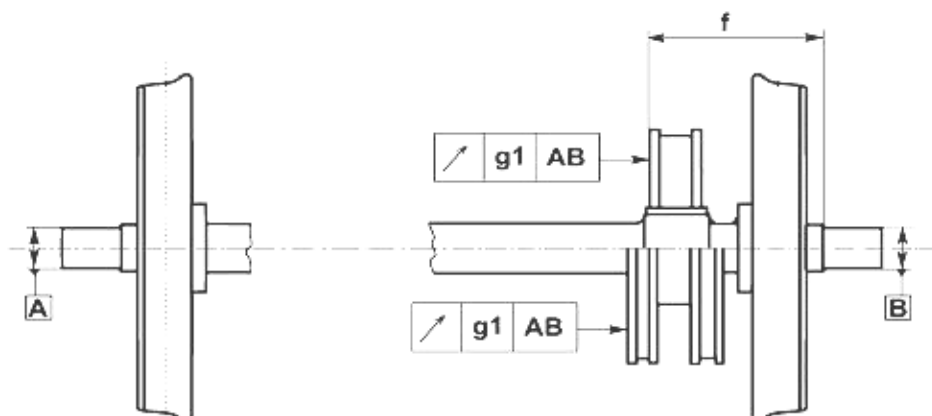

Figure 2 — Single-seat axle for one or two brake discs

Table 5 — Tolerances for single-seat axles for one or two brake discs

Dimensions in mm

Description	Symbol	Category 1 and 2
Distance between the internal face of the disc crown and the plane on the journal side defining the corresponding collar bearing surface	f	$\pm 0,5$

3.2.5.3.3 Double-seat axles for two or four brake discs

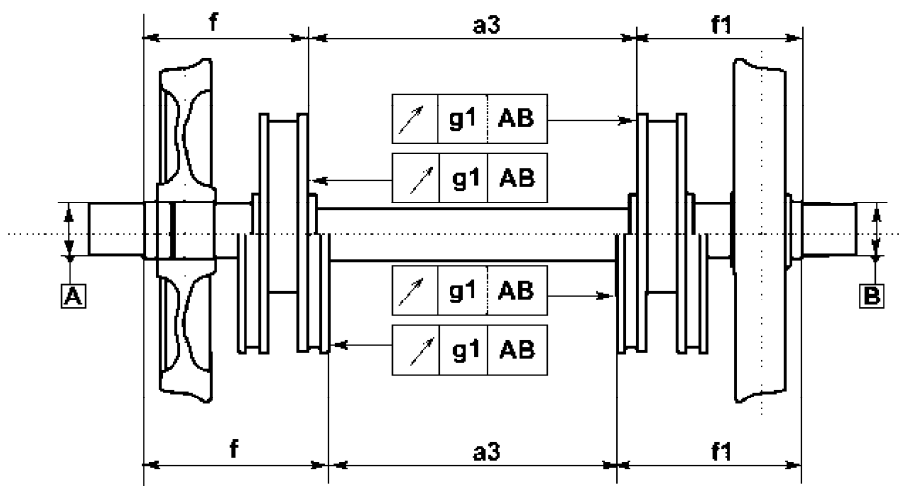

Figure 3 — Double-seat axles for two or four brake discs

Table 6 — Tolerances for double-seat axles for two or four brake discs

Dimensions in mm

Description	Symbol	Category 1 and 2
Distance between the internal faces of the disc crowns	a_3	$\pm 0,5$
Difference in distances between the internal face of each disc and the plane on the journal side defining the corresponding collar bearing surface	$f - f_1$ or $f_1 - f$	≤ 1

3.2.5.3.4 More than two seats

If there are more than two seats for the brake discs, the tolerances on the dimensions such as a_3 or $f - f_1$ (see Figure 3) are the same as in 3.2.5.3.3.

3.2.5.4 Cylindrical gear wheels for motor axle, reducing gears etc.

The tolerances of the parameters defined in Figure 4 shall be those required by Table 7.

Table 7 — Tolerances for cylindrical gear wheels for motor axle, reducing gears etc.

Dimensions in mm

Description	Symbol	Category 2	Category 1
Radial run-out ^a	h_1	b	b
Axial run-out ^a	g_2	b	b
Distance between the lateral reference surface of the gear wheel and the plane on the journal side defining the corresponding collar bearing surface ^a	c_2	$\pm 0,5$	$\pm 0,2$
^a See Figure 4.			
^b In accordance with the specifications of the designer.			

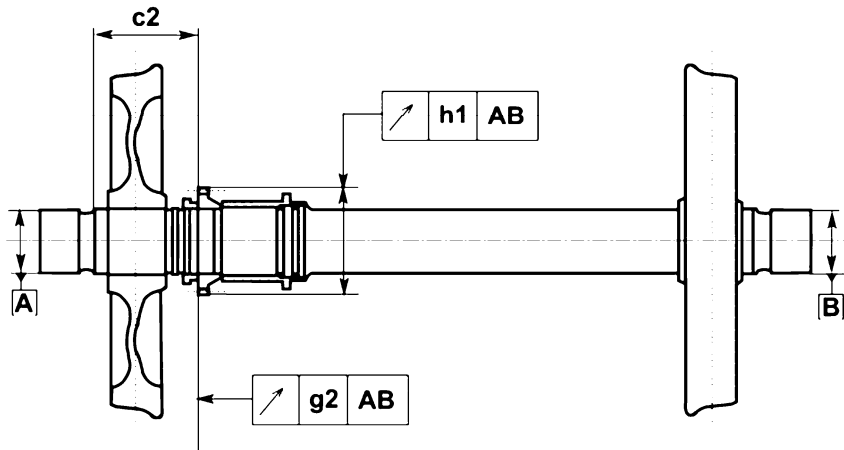

Figure 4 – Cylindrical gear wheels for motor axle, reducing gears etc.

3.2.6 Residual stresses

3.2.6.1 General

The different manufacturing operations leading to a "ready to assemble" state for the axle shall not create residual stresses likely to facilitate fatigue crack initiation.

3.2.6.2 Values to be achieved

On the axle seats at a depth of 0,1 mm below the surface, the residual stresses shall be $\leq 100 \text{ N/mm}^2$ in tension.

3.2.6.3 Test piece and position of the measuring points

The test piece is the axle in the "ready to assemble" state. The measuring points are located at the centre and at one end of the seats. On each circumference, two points are measured at 120° .

3.2.6.4 Measurement method

The measurements can be made either with conventional strain gauges or by X-ray diffraction.

3.2.7 Protection against corrosion and impacts

The wheelset components shall be protected according to the requirements of their relevant standards.

Cavities arising from the overhang of the wheel hub on the wheel seats shall be protected or filled with an anticorrosion product.

3.2.8 Marking

The constituent parts of the wheelsets shall be marked according to the relevant standards.

The wheelset shall be identified as a minimum by the following marks (in accordance with the purchase order):

- 1) type of wheelset;
- 2) serial number;

- 3) assembler's marks;
- 4) date of assembly;
- 5) owner's marks.

These marks shall be located at the end of the journal which already bears the axle marks defined in EN 13261 and be below the latter marks.

At the other end of the journal, one half the surface shall be free of any marks. It is reserved for maintenance identification. The other half of this surface is free for any other marking.

The marks shall be stamped. Any protruding burrs resulting from the stamping shall be levelled to allow ultrasonic examination to be carried out in service.

Annex A (normative)

Characteristics of the press-fitting curve

The characteristics of the press-fitting curve are described in Figure A.1. The fitting force shall start to increase before the wheel seat displacement on to the wheel hub reaches 30 mm. The force shall then increase continuously without falling outside the limit curve values given by the curves stated by the designer of the component to be fitted.

Nevertheless, the following cases are permitted:

- 1) a reduction in the fitting force at the groove for removal by oil injection is permitted. The maximum force reached before the groove shall be reached again within a further displacement of 25 mm. During this decrease, the fitting force value may be lower than that defined by the lower curve;
- 2) a maximum decrease of 0,05 MN over the last 25 mm of displacement;
- 3) curves showing local deviation, if previously agreed between the customer and supplier, or on qualification of the product.

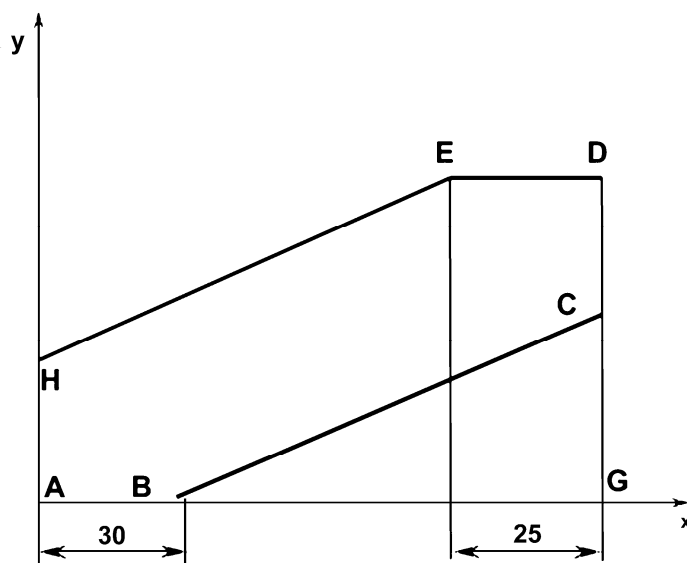

NOTE

- AB, BC, HE and ED are portions of a straight line, AG is equal to the length of the seat;

- for the wheels, the positions of the different points are as follows:

$$Y_H = 1,3 \varnothing; Y_C = 0,85 F; Y_D = Y_E = 1,45 F,$$

\varnothing = nominal diameter of the wheel seat, in metres

F = fitting force specified by the designer of the component to be fitted (wheel, disc, gear wheel, etc.)

Key

x distance in mm

y fitting force F (mN)

Figure A.1 — Characteristics of the press-fitting curve

Annex B
(normative)

Fatigue characteristics for a wheelset with an axle of steel grade EA1T or EA4T

The fatigue characteristics for a wheelset with an axle of steel grade EA1T or EA4T are defined in Table B.1.

Table B.1 — Minimum stress values in N/mm²

Grade	F_3	F_4	F_5
EA1T	120	110	94
EA4T	145	132	113

Annex C (informative)

Information on the test pieces for fatigue tests

The drawing of the test piece for fatigue tests is shown in Figure C.1.

NOTE This test piece is designed with a diameter ratio, \varnothing wheel seat (185)/ \varnothing body (171) of 1,08. This diameter ratio is chosen in order to ensure verification of the assembly against fatigue resistance of the wheelset. If ever cracks occur, they will appear on the wheel seat and not on the body. This value may not be valid for high-alloy steels. Higher diameter ratios (lower than 1,12) can be used for all steel grades in this standard, but:

- with high ratios, there is a risk that the cracks appear in the body radius;
- with low ratios, there is a risk that the required stress on the wheel seat may not be reached.

Dimensions in millimetres

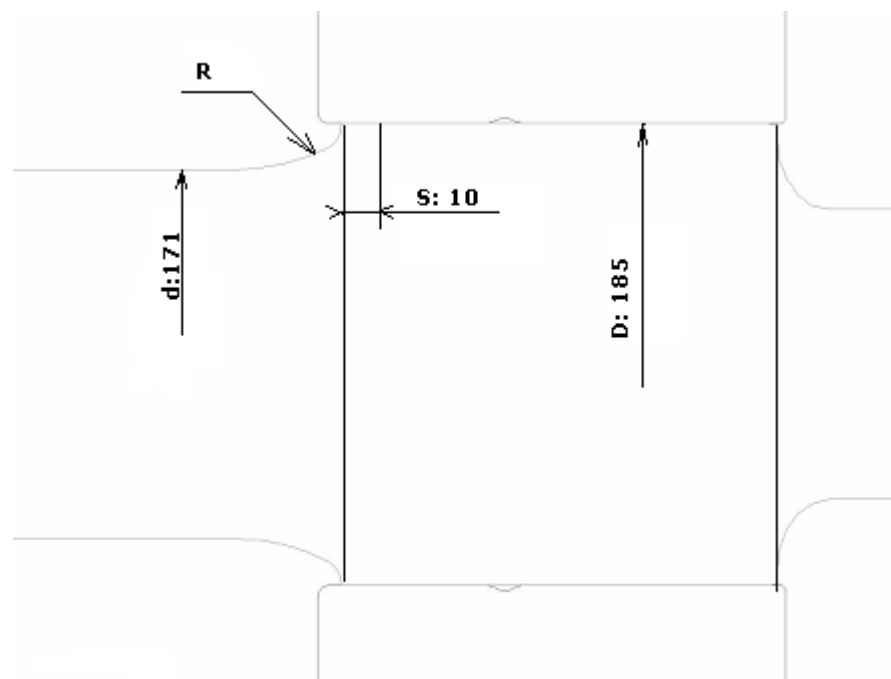

Key

- S reference section 10 mm from the end of the wheel seat
- R radius according to the geometry defined in EN 13103

Figure C.1 — Drawing of the test piece geometry required for fatigue tests

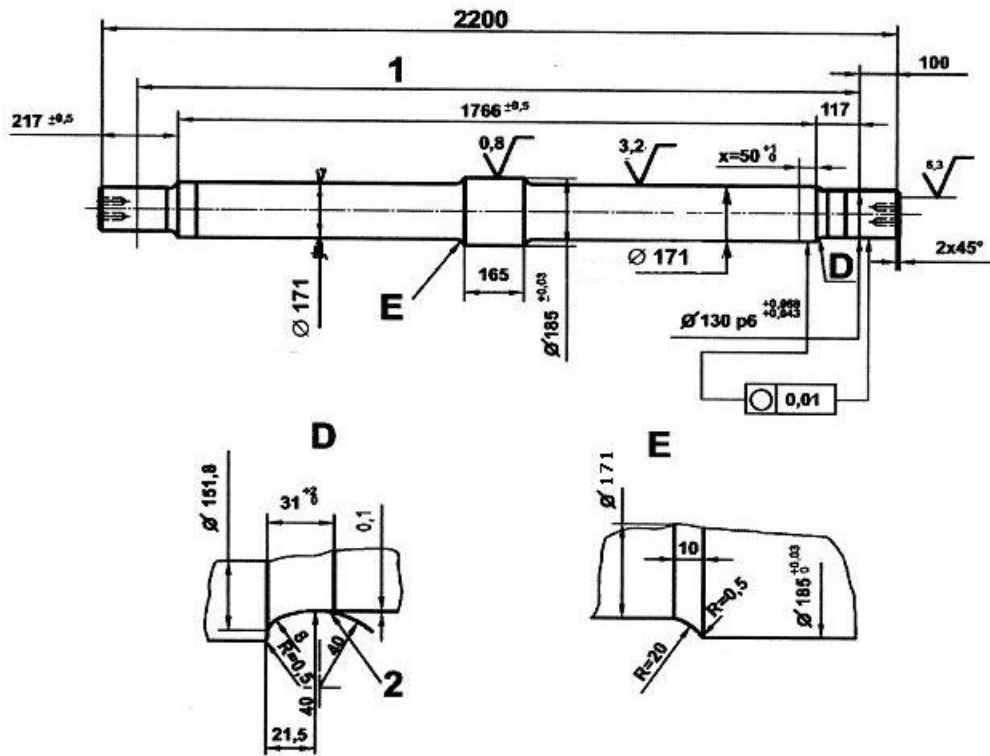

Key

- 1 centre to centre dimension of journals 2000
- 2 rounded edge

Figure C.2 — Example of a test piece

Annex D (informative)

Documents for the identification of wheelset components

Two documents are given in this Annex:

- 1) Figure D.1 shows the document to be used for a single wheelset, usually of category 1 or a powered wheelset;
- 2) Figure D.2 shows the document that can be used for a number of wheelsets.

For these two documents, a summary of the information contained therein is given in Table D.1.

Wheelset	Type	22
	Serial number	4
	Ownership mark	

1- Constituent elements

	Axle	LH wheel	RH wheel
Drawings	34	36	
Wheel ref.		36	36
Supplier	35	37	37
Grade	7	11	11
Cast no./serial no.	5/6	9	9
Delivery date	8	10	10
Wheel dia.		14	14
		LH disc	RH disc
Drawing		40	40
Disc ref.		46	46
Supplier		47	47
Delivery date		48	48

Axle box bearings	LH	RH
Type	30	
Supplier	41	
Serial no.	42	42
Date of manufacture	43	43
Assembly date	44	

Grease	31	
Batch no.	31	31
Date of manufacture	31	31
Date of greasing	44	44

Other components

	Motor axle	Transmission
Drawing		
Serial no.		
Supplier		
Delivery date		

2 - Assembly characteristics

	Wheels			Discs			Gear wheels	
	Allow.	LH meas.	RH meas.	Allow.	LH meas.	RH meas.	Allow.	Meas.
Assembly	29	13	13	49	50	50	56	57
Fitting force	28	12	12	51	52	52	58	59
Assembly condition	PF/SF	45		45		45		
	Char.	53		53		53		

Bearing play				Weight of grease
Allowable				
max	53	min	53	55
LH meas.		RH meas.		
54		54		

3 - Controls

	Wheels			Discs			Gear wheels	
	Allow.	LH meas.	RH meas.	Allow.	LH meas.	RH meas.	Allow.	Meas.
Radial run-out	60	61	61	60	61	61	60	67
Axial run-out	69	61	61	60	61	61	60	67

Imbalance		Electrical resistance	
Allow.	Meas.	Allow.	Meas.
63	64	63	65

4 - Corrosion protection

Type of paint: 66
Type of coating: 66

5 - Distance between inside faces

	Free
Allowed	67
A	67
B	67
C	67
D	67

Name of inspector	Company	Date	Signature	Order No.
33	1			16
1 - Representative of wheelset manufacturer				

Figure D.1 — Document for identification of components of a single wheelset, usually of category 1 or of a powered wheelset

14

1		Wheelset report										Subject of report No. 15				Annex 17					
		Components																		Internal reference 16	
		Axle grade 7				LH wheel steel grade 11						Interference				RH wheel steel grade 11				Interference	
2	3	4	5	6	8	9	10	14	13a	13b	13c	12	9	10	14	13a	13b	13c	12		
Works no.	Ownership mark	Serial number	Cast no.	Serial no.	Date	Cast no.	Date	Wheel diameter	Wheel bore diameter	Axle seat diameter	Interference	Fitting force	Cast no.	Date	Wheel diameter	Wheel bore diameter	Axle seat diameter	Interference	Fitting force		
Balancing 18					Allowable min.			29					28		29					28	
Axial run-out					Radial run-out 20			Allowable max.													
Wheelset 22		Bearing type 30		Grease 31		Batch no. 19															
Customer name 21				Customer order no. 24						Destination 25											
Vehicle no. 23/26										Tare 26				Loading date 27							

Figure D.2 — Document for identification of components of several wheelsets

Table D.1 — Information on the characteristics of the wheelsets

Elements	Reference	Identification
Manufacturer of the wheelsets	1 (2,3,4)	Name and production plant
Customer order references	15 16 17 21 24 33	Drawing reference Internal order number Reference of any annexes Customer's name Customer order reference Inspector's name
Axle identification	5 6 7 8 34 35	Cast number Serial number Steel grade Month and year of manufacture Axle drawing Manufacturer
Wheel identification	9 10 11 12 13 a 13 b 13 c 14 28 29 32 36 37 45 53	Cast number Month and year of manufacture Steel grade Fitting pressure Wheel bore diameter Wheel bearing diameter Assembly Wheel diameter Tolerance on fitting pressure Tolerance on interference Type of lubricant Wheel drawing and markings Wheel manufacturer Type of assembly (SF for shrink-fitting, PF for press-fitting) Type of lubricant if PF, type of heating temperature if SF
Bearing identification	30 31 41 42 43 44 53 54 55	Type of axle box bearings Type of grease, batch number, date of manufacture Supplier Bearing serial number Date of manufacture Date of assembly Allowable bearing play Measured bearing play Weight of grease
Disc/brake identification	40 46 47 48 49 50 51 52	Drawing Serial number Manufacturer Delivery date Tolerance on disc interference Measured value of disc interference Tolerance on fitting force Fitting pressure value
Other suitable elements	56 57 58 59	Imposed interference Measured interference Imposed fitting force Measured fitting force
Controls	60 61 63 64 65 66 67	Allowable axial run-out Measured axial run-out Maximum allowable imbalance Measured maximum imbalance Good or bad Type of paint Measurement of internal faces of free wheelset
Wagon reference	23/26 25 27	Vehicle references (weight, number, etc.) Delivery site Loading date
Wheels and wheelset	18 19 20	Imbalance Batch number Axial run-out/radial run-out

Annex E (informative)

Product qualification

CEN/TC 256 considers that the following clauses represent the best means of assessing conformity of a range of products to this standard. However, a quality system other than the one specified in EN ISO 9001 may be applied.

E.1 General

A wheelset shall be qualified before being used on a European network.

This clause specifies the requirements and procedures to be applied for product qualification.

Qualification of a wheelset is directly linked to the supplier and a wheelset can only be qualified if the supplier meets the requirements specified in E.2.1.

These requirements are to be applied in the following cases:

- 1) any wheelset from a new supplier;
- 2) any change in the components comprising the wheelset.

E.2 Requirements

E.2.1 Requirements to be met by the supplier

E.2.1.1 General

Where manufacture of a wheelset involves more than one supplier, the following requirements shall be met by all concerned.

E.2.1.2 Quality organization

The supplier should operate a quality assurance system conforming to EN ISO 9001.

E.2.2 Qualification of personnel

The personnel responsible for non-destructive testing shall be qualified according to EN 473.

E.2.2.1 General

E.2.2.2 Equipment

The equipment used by the supplier for manufacture, control and monitoring shall allow the requirements of this standard to be met.

E.2.3 Requirements to be met by the product

The product shall meet the product requirements specified in clause 3.

The traceability of each component and its assembly shall be established.

E.3 Qualification procedure

E.3.1 General

The qualification procedure comprises four successive stages:

- 1) supply of file by the supplier;
- 2) evaluation of the manufacturing equipment and the manufacturing processes;
- 3) laboratory tests;
- 4) product testing.

E.3.2 Documentation required

When a request for qualification is submitted, the supplier shall provide a file comprising:

- 1) a description of the products that are the subject of the request;
- 2) a description of the company stating:
 - a) company size (number of employees, defining the proportion between production, control and quality assurance);
 - b) annual production of all the products;
 - c) a list of all the means of production and control;
- 3) data about the company organization, with the relevant organization charts;
- 4) a description of the manufacturing processes with explanations of the different stages of manufacture;
- 5) qualification documents for the various components of the product to be qualified;
- 6) results of tests on the products submitted for qualification

If a file has already been provided by the supplier for the qualification of a different wheelset, the file to be provided by this supplier for qualification of a new wheelset shall only include elements specific to this product or new to the company.

E.3.3 Evaluation of the manufacturing plant and processes

This evaluation comprises:

- 1) inspection of the manufacturing plant and examination of the production processes;
- 2) inspection of the wheelset components manufacturing plant and examination of their production processes;
- 3) auditing of the manufacturing organization to confirm whether the requirements of E.2.1 have been met;

4) auditing of the information supplied in the documents referred to in E.3.1.

At the end of this stage, a report shall be produced. It shall identify all the production processes including those of the wheelset components. It shall give an assurance that the evaluation satisfies the requirements of E.2.1 for the qualification procedure to continue.

E.3.4 Laboratory tests

This stage shall verify that the fatigue limits defined in 3.2.2 have been achieved and the levels of residual stress are as defined in 3.2.6.

At the end of this stage, a report shall be produced. It shall confirm the geometry and the production process of the test pieces.

E.3.5 Testing of finished products

All the characteristics defined in clause 3 (except for fatigue characteristics and residual stress characteristics) are to be verified on 10 wheelsets.

Residual stresses defined in 3.2.6 are to be verified on two axles.

A report shall be issued describing both the wheelsets subjected to the test and the test procedures and results. It shall specify whether or not the wheelsets meet the requirements.

If the outcome is satisfactory, a provisional qualification certificate may be issued.

Once this provisional qualification certificate has been awarded, the same verifications as carried out on the 10 wheelsets shall be carried out on at least one wheelset in each 30 wheelsets until 300 wheelsets have been delivered.

The product is qualified if these verifications do not show any repeated defects in the product.

Another report shall be issued. It shall identify the wheelsets, the verifications and their results.

If the number of wheelsets to be supplied in 2 years is less than 300, the qualified status is given after the tests on the first 10 wheelsets. However, the same verifications as carried out on the first 10 wheelsets shall be carried out on one in every 30 of the following wheelsets supplied.

E.4 Qualification certificate

E.4.1 Condition of validity

The certificate of qualification shall specify the limits of validity for:

- 1) the diameters and lengths of the seats;
- 2) the steel grades and the geometry of the different components of the wheelset;
- 3) the level of residual stresses induced in the hub by the fitting.

E.4.2 Modification and extension

At the request of the supplier, the scope of the certification validity can be modified or extended if:

- 1) other products are to be considered;

- 2) important parameters have been modified (manufacturing processes, quality organization, etc.).

E.4.3 Transference

In the case of a change in ownership, an existing qualification may, if requested, be transferred to another company if the relevant content and conditions prior to the qualification have not been modified.

E.4.4 Lapsed certification

The manufacturing equipment and processes described in E.3.3 shall be re-assessed in the following cases:

- 1) if, after 5 years, 300 wheelsets have not been supplied following the provisional qualification;
- 2) if, in a period of 2 years, no wheelsets have been supplied within the scope of the product that was the subject of the qualification.

E.4.5 Cancellation

If the customer registers significant defects in the product, the parts of the qualification procedure concerned shall be repeated.

If the supplier has not ensured that important conditions of the qualification were met, it may be cancelled.

E.5 Qualification file

A qualification file shall be prepared for each qualified product. It shall contain the following documents:

- 1) the application request from the supplier;
- 2) the documents provided by the supplier (see E.3.2);
- 3) the evaluation reports (see E.3.3);
- 4) the laboratory test reports (see E.3.4);
- 5) the product test reports (see E.3.5);
- 6) the qualification certificate (see E.4).

Annex F (informative)

Product delivery

CEN/TC 256 considers that the following clauses represent the best means of assessing conformity of the products delivered to this standard.

F.1 General

The customer shall define the following in the order:

- 1) the geometry and the dimensions of the wheelset components (drawings);
- 2) the drawings of the wheelset;
- 3) the category of the wheelset;
- 4) the press-fitting or shrink-fitting requirements;
- 5) the ultrasonic test method, if this test is required (see F.3.2);
- 6) the marking of the wheelset (see 3.2.8).

The customer and the supplier shall agree on the following points:

- 7) the fitting method (see 3.1.1);
- 8) the electrical resistance test method (see 3.2.3);
- 9) the imbalance test method (see 3.2.4);
- 10) the optional dimensional controls (see F.3.1).

For delivery, some characteristics are verified on each wheelset (see F.2). For the other characteristics defined in clause 3, the supplier shall propose a product quality plan (in accordance with the definition in EN ISO 9000) which shall be agreed with the customer.

Each wheelset shall have documents which record its traceability.

F.2 Specific verifications

The following checks shall be carried out on each wheelset:

- 1) conformity of the fitting diagram for press-fitting (see 3.1.3);
- 2) dimensions: d , d_1 , h , g , a_1 (see 3.2.5.2).

For shrink-fitting, the resistance of the assembly shall be verified on 10 % of the wheelsets supplied (see 3.2.1).

F.3 Optional checks

F.3.1 Dimensional check

Following agreement between the customer and the supplier, other dimensions defined in 3.2.5 may be verified on all or a proportion of the wheelsets delivered.

F.3.2 Ultrasonic examination

If required by the operator's maintenance policy, the axles of the assembled wheelsets may be subject to an ultrasonic examination in order to detect any defects of a critical size resulting from the assembly.

The process shall conform to an agreed procedure and shall be carried out by certified and authorized operators using approved equipment.

An authorized calibration axle shall be available to calibrate the equipment prior to the examination.

An individual permanent record shall be made of each test.

F.4 Allowable rectification

Repairs to wheelsets are authorized if the following requirements are met:

- 1) excessive imbalance, dimensions or geometrical tolerances beyond allowable limits shall be corrected by machining or grinding within the dimensions and tolerances given in the drawings and standards for each component;
- 2) a defective assembly of one of the components can be corrected by dismantling and re-assembly of this component;;
- 3) different shapes of the fitting curves (in the case of press-fitting) are tolerated within the limits of the standard diagrams that have been agreed between the customer and the supplier;
- 4) after machining, any defect that can have an adverse effect on the integrity of the wheelset shall be removed;
- 5) damage to the corrosion protection can be repaired if, after repair, the characteristics of the repaired zones are the same as those of the other zones;
- 6) if, during press-fitting, dismantling or a proof-loading operation, the fitted surfaces of the two components in contact are damaged, re-use of these components is allowed under the following conditions:
 - a) the components to be assembled can be re-used with a new axle if the latter has two wheel seats with a diameter greater than the tolerances of the drawing, up to a maximum of + 1,5 mm, in order to adjust the interference;
 - b) if the damage involved scoring of the wheel seat during dismantling, the seat can be machined to remove the scoring and another wheel can be fitted as long as 50 % of the thickness allowance used for maintenance purposes remains and this has been agreed with the customer;
 - c) an approved method of metal spraying to obtain the correct interference is allowed. It shall be agreed beforehand with the customer. In addition, this method shall be qualified by a procedure that includes fatigue testing in order to prove that the fatigue characteristics of such a repaired wheelset are the same as those of a non-repaired wheelset.

Whenever an allowable rectification is used, it shall be described in the traceability documents for the rectified wheelset.

F.5 Documents

F.5.1 Shrink-fitting

For each shrink-fitted element, there shall be assigned a document with the following information:

- 1) name of the supplier carrying out the fitting operation;
- 2) date of the fitting operation;
- 3) identification of the wheelset;
- 4) fitted element (wheel, disc, etc.);
- 5) dimensions:
 - a) mean diameter of the seat,
 - b) mean diameter of the bore of the fitted element hub,
 - c) interference,
- 6) position "R" (right) or "L" (left) if two identical elements are fitted to one axle;

Examples of the documents are given in Annex D.

F.5.2 Press-fitting

For each press-fitted element, there shall be assigned a press-fitting diagram record (see 3.1.3) which shall contain the following information:

- 1) name of the supplier carrying out the fitting operation;
- 2) date of the fitting operation;
- 3) identification of the wheelset;
- 4) fitted element (wheel, disc, etc.);
- 5) dimensions:
 - a) mean diameter of the seat;
 - b) mean diameter of the bore of the fitted element hub;
 - c) interference;
- 6) position "R" (right) or "L" (left) if two identical elements are fitted to one axle;
- 7) final fitting force F .

This information may be listed in the documents given in Annex D.

F.5.3 Components

For each wheelset, the identification of each component shall be recorded in a document as described in Annex D,

F.6 Quality plan

F.6.1 General

The quality plan shall be drawn up by the supplier and be agreed with the customer.

This quality plan shall refer to the quality manual and shall contain the elements specific to the product.

F.6.2 Objectives

The aim of this plan which shall be drawn up at the time of the offer is to describe the arrangements made by the supplier to achieve and control the quality of the products involved. Where optional requirements have been selected, these shall be justified.

This quality plan shall specify the inspection required during manufacture and on the delivered products. The inspection requirements may be listed in a manufacturing control plan.

F.6.3 Validity

Any modification to the quality plan shall be made known to the customer and be agreed with him.

If any non-conformity is detected by the customer on the delivered product, the quality plan shall be reviewed.

Annex ZA (informative)

Relationship between this European Standard and the Essential Requirements of Council Directive 96/48/EC of 23 July 1996 on the interoperability of the trans-European high-speed rail system amended by Directive 2004/50/EC of 29 April 2004

This European Standard has been prepared under a mandate given to CEN/CENELEC/ETSI by the European Commission and the European Free Trade Association to provide one means of conforming to Essential Requirements of the New Approach Directive 96/48/EC amended by Directive 2004/50/EC.

Once this standard is cited in the Official Journal of the European Communities under that Directive and has been implemented as a national standard in at least one Member State, compliance with the normative clauses of this standard indicated in Table ZA.1 confers, within the limits of the scope of this standard, a presumption of conformity with the relevant Essential Requirements of that Directive and associated EFTA regulations.

Table ZA.1 — Correspondence between this European Standard and Directive 96/48/EC

Clause(s)/sub-clause(s) of this EN	Clauses/subclauses/points and annexes of the June 2006 TSI adopted by the Council on 21 February 2008	Corresponding text, clauses/subclauses/annexes of Directive 96/48/EC
The whole standard is applicable	4.2.3.3.1 Electrical characteristics 4.2.3.4.1 Dynamic rolling stock behaviour. General 4.2.3.9.1 Wheelsets Annex M	Annex III, Essential requirements, General requirements – 1.1.1, 1.1.2, 1.1.3 Safety Annex III, Essential requirements, General requirements – 1.5 Technical compatibility Annex III, Essential requirements, Requirements specific to each subsystem "Control and Command and Signalling" – 2.3.2 Technical compatibility Annex III, Essential requirements, Requirements specific to each subsystem "Rolling stock" – 2.4.2 Reliability and availability 2.4.3 § 3 Technical compatibility

WARNING — Other requirements and other EU Directives may be applicable to the product(s) falling within the scope of this standard.

Annex ZB (informative)

Relationship between this European Standard and the Essential Requirements of Directive 2001/16/EC of the European Parliament and of the Council of 19 March 2001 on the interoperability of the trans-European conventional rail system amended by Directive 2004/50/EC of 29 April 2004

This European Standard has been prepared under a mandate given to CEN/CENELEC/ETSI by the European Commission and the European Free Trade Association to provide one means of conforming to Essential Requirements of the New Approach Directive 2001/16/EC amended by Directive 2004/50/EC.

Once this standard is cited in the Official Journal of the European Communities under that Directive and has been implemented as a national standard in at least one Member State, compliance with the normative clauses of this standard indicated in Table ZB.1 confers, within the limits of the scope of this standard, a presumption of conformity with the relevant Essential Requirements of that Directive and associated EFTA regulations.

Table ZB.1 — Correspondence between this European Standard and Directive 2001/16/EC

Clause(s)/sub-clause(s) of this EN	Clauses/subclauses/points and annexes of the January 2005 rolling stock – freight wagon TSI and approved by the committee on the interoperability and safety of the European rail system	Corresponding text, clauses/subclauses/annexes of Directive 2001/16/EC
The whole standard is applicable	<p>4.2.3.3.1 Electrical resistance</p> <p>4.2.3.4.1 Vehicle dynamic behaviour. General</p> <p>5.3.2.2 Vehicle track interaction and gauging. Wheelset</p> <p>5.4.2.2 Vehicle track interaction and gauging. Wheelset</p> <p>6.1.3.2.2 Vehicle track interaction and gauging. Wheelset</p> <p>Annex E: Vehicle track interaction and gauging, Wheelset dimensions and tolerances for standard gauge</p> <p>Annex K: Vehicle track interaction and gauging, Wheelset</p> <p>Annex Q: Assessment procedures, interoperability constituents</p> <p>Annex Y: Constituents, bogies and running gear</p>	<p>Annex III, Essential requirements, General requirements – 1.1.1, 1.1.2, 1.1.3 Safety</p> <p>Annex III, Essential requirements, General requirements – 1.5 Technical compatibility</p> <p>Annex III, Essential requirements, Requirements specific to each subsystem "Control and Command and Signalling" – 2.3.2 Technical compatibility</p> <p>Annex III, Essential requirements, Requirements specific to each subsystem "Rolling stock" –</p> <p>2.4.2 Reliability and availability</p> <p>2.4.3 § 3 Technical compatibility</p>

	Clauses/subclauses/points and annexes of the Conventional Rail Rolling Stock TSI for Locomotives and Traction Units (draft submitted to the committee on the interoperability and safety of the European rail system in September 2008)	
	<i>4.2.3.3.1 Rolling stock parameters affecting the CCS subsystem</i> <i>4.2.3.5.2 Wheelsets</i> <i>4.2.3.5.2.1 Mechanical and geometric characteristics of wheelsets</i> <i>5.3.2.2 Wheelsets</i>	

WARNING — Other requirements and other EU Directives may be applicable to the product(s) falling within the scope of this standard.

Bibliography

- [1] EN 473, *Non-destructive testing – Qualification and certification of NDT personnel – General principles*
- [2] EN 12080, *Railway applications – Wheelsets and bogies – Axleboxes – Rolling bearings*
- [3] EN 14535-1, *Railway applications – Brake discs for railway rolling stock – Part 1: Brake discs pressed or shrunk onto the axle or drive shaft, dimensions and quality requirements*
- [4] EN ISO 9000, *Quality management systems – Fundamentals and vocabulary (ISO 9000:2005)*
- [5] EN ISO 9001, *Quality management systems – Requirements (ISO 9001:2000)*

BSI - British Standards Institution

BSI is the independent national body responsible for preparing British Standards. It presents the UK view on standards in Europe and at the international level. It is incorporated by Royal Charter.

Revisions

British Standards are updated by amendment or revision. Users of British Standards should make sure that they possess the latest amendments or editions.

It is the constant aim of BSI to improve the quality of our products and services. We would be grateful if anyone finding an inaccuracy or ambiguity while using this British Standard would inform the Secretary of the technical committee responsible, the identity of which can be found on the inside front cover. Tel: +44 (0)20 8996 9000. Fax: +44 (0)20 8996 7400.

BSI offers members an individual updating service called PLUS which ensures that subscribers automatically receive the latest editions of standards.

Buying standards

Orders for all BSI, international and foreign standards publications should be addressed to Customer Services. Tel: +44 (0)20 8996 9001. Fax: +44 (0)20 8996 7001 Email: orders@bsigroup.com You may also buy directly using a debit/credit card from the BSI Shop on the Website <http://www.bsigroup.com/shop>

In response to orders for international standards, it is BSI policy to supply the BSI implementation of those that have been published as British Standards, unless otherwise requested.

Information on standards

BSI provides a wide range of information on national, European and international standards through its Library and its Technical Help to Exporters Service. Various BSI electronic information services are also available which give details on all its products and services. Contact Information Centre. Tel: +44 (0)20 8996 7111 Fax: +44 (0)20 8996 7048 Email: info@bsigroup.com

Subscribing members of BSI are kept up to date with standards developments and receive substantial discounts on the purchase price of standards. For details of these and other benefits contact Membership Administration. Tel: +44 (0)20 8996 7002 Fax: +44 (0)20 8996 7001 Email: membership@bsigroup.com

Information regarding online access to British Standards via British Standards Online can be found at <http://www.bsigroup.com/BSOL>

Further information about BSI is available on the BSI website at <http://www.bsigroup.com>.

Copyright

Copyright subsists in all BSI publications. BSI also holds the copyright, in the UK, of the publications of the international standardization bodies. Except as permitted under the Copyright, Designs and Patents Act 1988 no extract may be reproduced, stored in a retrieval system or transmitted in any form or by any means – electronic, photocopying, recording or otherwise – without prior written permission from BSI.

This does not preclude the free use, in the course of implementing the standard, of necessary details such as symbols, and size, type or grade designations. If these details are to be used for any other purpose than implementation then the prior written permission of BSI must be obtained.

Details and advice can be obtained from the Copyright and Licensing Manager. Tel: +44 (0)20 8996 7070 Email: copyright@bsigroup.com