



BSI Standards Publication

Plastics — Unplasticized poly(vinyl chloride) (PVC-U) profiles for building applications

Part 1: Designation of PVC-U profiles

NO COPYING WITHOUT BSI PERMISSION EXCEPT AS PERMITTED BY COPYRIGHT LAW

raising standards worldwide[™]

National foreword

This British Standard is the UK implementation of EN 13245-1:2010. It supersedes BS EN 13245-1:2004 which is withdrawn.

The UK participation in its preparation was entrusted to Technical Committee PRI/82, Thermoplastic materials.

A list of organizations represented on this committee can be obtained on request to its secretary.

This publication does not purport to include all the necessary provisions of a contract. Users are responsible for its correct application.

© BSI 2010

ISBN 978 0 580 64556 3

ICS 83.140.99

Compliance with a British Standard cannot confer immunity from legal obligations.

This British Standard was published under the authority of the Standards Policy and Strategy Committee on 31 July 2010

Amendments issued since publication

Date	Text affected
------	---------------

English Version

Plastics - Unplasticized poly(vinyl chloride) (PVC-U) profiles for building applications - Part 1: Designation of PVC-U profiles

Plastiques - Profilés en poly(chlorure de vinyle) non plastifié
(PVC-U) pour applications dans le bâtiment - Partie 1:
Désignation des profilés en PVC-U

Kunststoffe - Profile aus weichmacherfreiem
Polyvinylchlorid (PVC-U) für die Anwendung im Bauwesen -
Teil 1: Bezeichnung von Profilen aus PVC-U

This European Standard was approved by CEN on 19 May 2010.

CEN members are bound to comply with the CEN/CENELEC Internal Regulations which stipulate the conditions for giving this European Standard the status of a national standard without any alteration. Up-to-date lists and bibliographical references concerning such national standards may be obtained on application to the CEN Management Centre or to any CEN member.

This European Standard exists in three official versions (English, French, German). A version in any other language made by translation under the responsibility of a CEN member into its own language and notified to the CEN Management Centre has the same status as the official versions.

CEN members are the national standards bodies of Austria, Belgium, Bulgaria, Croatia, Cyprus, Czech Republic, Denmark, Estonia, Finland, France, Germany, Greece, Hungary, Iceland, Ireland, Italy, Latvia, Lithuania, Luxembourg, Malta, Netherlands, Norway, Poland, Portugal, Romania, Slovakia, Slovenia, Spain, Sweden, Switzerland and United Kingdom.



EUROPEAN COMMITTEE FOR STANDARDIZATION
COMITÉ EUROPÉEN DE NORMALISATION
EUROPÄISCHES KOMITEE FÜR NORMUNG

Management Centre: Avenue Marnix 17, B-1000 Brussels

Contents

Page

Foreword.....	3
1 Scope	4
2 Normative references	4
3 Terms and definitions	5
4 Designation of PVC-U profiles	6
5 Codification system for Data block 3 to Data block 5	7
5.1 Vicat softening temperature (Data block 3)	7
5.2 Modulus of elasticity in flexure (Data block 3)	7
5.3 Nominal linear mass (Data block 4)	8
5.4 Heat reversion at 100 °C (Data block 4)	8
5.5 Impact resistance (Data block 4)	8
5.6 Durability (Data block 5)	9
6 Required characteristics for Type 3 and Type 4 profiles	13
6.1 Resistance to cross cut (only for Type 4 profiles)	13
6.2 Thermal resistance (only for Type 3 and Type 4 profiles)	13
6.3 Water vapour resistance (only for Type 3 and Type 4 profiles, intended to be used for inside building applications)	13
6.4 Peel strength (only for Type 3 profiles)	13
7 Optional characteristics	13
7.1 Resistance to staining	13
7.2 Appearance and finishing of the coating (only for Type 3 and Type 4 profiles)	14
8 Example of the designation of a PVC-U profile	14
9 Use of reprocessible and recyclable material	15
Annex A (normative) Determination of the linear mass	16
A.1 Apparatus	16
A.2 Test specimens	16
A.3 Procedure	16
A.4 Calculation and expression of results	16
Annex B (normative) Determination of the impact resistance	17
B.1 Principle	17
B.2 Apparatus	17
B.3 Test specimens	17
B.4 Conditioning	18
B.5 Procedure	18
B.6 Expression of results	19
Annex C (normative) Determination of peel strength	20
C.1 Principle	20
C.2 Apparatus	20
C.3 Preparation of test pieces	21
C.4 Conditioning	21
C.5 Procedure	21
C.6 Test report	22
Bibliography	23

Foreword

This document (EN 13245-1:2010) has been prepared by Technical Committee CEN/TC 249 "Plastics", the secretariat of which is held by NBN.

This European Standard shall be given the status of a national standard, either by publication of an identical text or by endorsement, at the latest by December 2010, and conflicting national standards shall be withdrawn at the latest by December 2010.

Attention is drawn to the possibility that some of the elements of this document may be the subject of patent rights. CEN [and/or CENELEC] shall not be held responsible for identifying any or all such patent rights.

This document supersedes EN 13245-1:2004.

EN 13245, *Plastics — Unplasticized poly(vinyl chloride) (PVC-U) profiles for building applications*, consists of the following parts:

- *Part 1: Designation of PVC-U profiles*
- *Part 2: PVC-U profiles and PVC-UE profiles for internal and external wall and ceiling finishes*
- *Part 3: Designation of PVC-UE profiles*

It is a revision of EN 13245-1:2004 with the extension of the scope to:

- light coloured PVC-U profiles with or without a laminated foil or a lacquered-coating;
- coloured PVC-U profiles, obtained by a mono-extrusion or a co-extrusion process, with or without laminated foil or with lacquered-coating.

According to the CEN/CENELEC Internal Regulations, the national standards organizations of the following countries are bound to implement this European Standard: Austria, Belgium, Bulgaria, Croatia, Cyprus, Czech Republic, Denmark, Estonia, Finland, France, Germany, Greece, Hungary, Iceland, Ireland, Italy, Latvia, Lithuania, Luxembourg, Malta, Netherlands, Norway, Poland, Portugal, Romania, Slovakia, Slovenia, Spain, Sweden, Switzerland and the United Kingdom.

1 Scope

This European Standard establishes a system of designation for profiles made of unplasticized poly(vinyl chloride) (PVC-U) intended to be used for building applications.

This part is applicable to light coloured and coloured PVC-U profiles, obtained by a mono-extrusion or a co-extrusion process, with or without a laminated foil or with a lacquered-coating.

It specifies test methods and test parameters.

This method of designation is intended to be used in product specification when the application is specified.

NOTE It is recommended to use this method for the designation of PVC-U profiles for information related to technical literature of the manufacturer, not for the marking of the products.

Profiles for the management of electrical power cables, communication cables and power track systems used for the distribution of electrical power, profiles for windows or doors and profiles for guttering are not covered by this European Standard.¹⁾

2 Normative references

The following referenced documents are indispensable for the application of this document. For dated references, only the edition cited applies. For undated references, the latest edition of the referenced document (including any amendments) applies.

EN 438-2:2005, *High-pressure decorative laminates (HPL) — Sheets based on thermosetting resins (usually called Laminates) — Part 2: Determination of properties*

EN 477:1995, *Unplasticized polyvinylchloride (PVC-U) profiles for the fabrication of windows and doors — Determination of the resistance to impact of main profiles by falling mass*

EN 478, *Unplasticized polyvinylchloride (PVC-U) profiles for the fabrication of windows and doors — Appearance after exposure at 150 °C — Test method*

EN 479, *Unplasticized polyvinylchloride (PVC-U) profiles for the fabrication of windows and doors — Determination of heat reversion*

EN 513:1999, *Unplasticized polyvinylchloride (PVC-U) profiles for the fabrication of windows and doors — Determination of the resistance to artificial weathering*

EN 20105-A02, *Textiles — Tests for colour fastness — Part A02: Grey scale for assessing change in colour (ISO 105-A02:1993)*

EN ISO 105-A01:2010, *Textiles — Tests for colour fastness — Part A01: General principles of testing (ISO 105-A01:2010)*

EN ISO 178, *Plastics — Determination of flexural properties (ISO 178:2001)*

EN ISO 306:2004, *Plastics — Thermoplastic materials — Determination of Vicat softening temperature (VST) (ISO 306:2004)*

EN ISO 472:2001, *Plastics — Vocabulary (ISO 472:1999)*

1) Profiles that are excluded are in the scopes of standards prepared by CEN/TC 33, CENELEC/TC 213 or CEN/TC 128.

EN ISO 1043-1:2001, *Plastics — Symbols and abbreviated terms — Part 1: Basic polymers and their special characteristics (ISO 1043-1:2001)*

EN ISO 1163-2, *Plastics — Unplasticized poly(vinyl chloride) (PVC-U) moulding and extrusion materials — Part 2: Preparation of test specimens and determination of properties (ISO 1163-2:1995)*

EN ISO 2409, *Paints and varnishes — Cross-cut test (ISO 2409:2007)*

EN ISO 2813, *Paints and varnishes — Determination of specular gloss of non-metallic paint films at 20°, 60° and 85° (ISO 2813:1994, including Technical Corrigendum 1:1997)*

EN ISO 4624, *Paints and varnishes — Pull-off test for adhesion (ISO 4624:2002)*

EN ISO 4892-2:2006, *Plastics — Methods of exposure to laboratory light sources — Part 2: Xenon-arc lamps (ISO 4892-2:2006)*

EN ISO 8256:2004, *Plastics — Determination of tensile-impact strength (ISO 8256:2004)*

ISO 7724-1:1984, *Paints and varnishes — Colorimetry — Part 1: Principles*

ISO 7724-2:1984, *Paints and varnishes — Colorimetry — Part 2: Colour measurement*

ISO 7724-3:1984, *Paints and varnishes — Colorimetry — Part 3: Calculation of colour differences*

3 Terms and definitions

For the purposes of this document, the terms and definitions given in EN ISO 472:2001 and EN ISO 1043-1:2001 and the following apply.

3.1

PVC-U profile

profile made of unplasticized poly(vinyl chloride) (PVC-U) material

NOTE It applies to profiles made of non-cellular material as opposed to cellular material.

3.2 Type of profile

3.2.1

Type 1 profile

PVC-U profile obtained by a mono-extrusion process (coloured in the mass)

3.2.2

Type 2 profile

PVC-U profile obtained by a co-extrusion process

3.2.3

Type 3 profile

PVC-U profile as Type 1 or Type 2 with laminated foil

3.2.4

Type 4 profile

PVC-U profile as Type 1 or Type 2 with lacquer-coating

3.3

sight surface

surface of a profile that is exposed to view, when the PVC-U profile is installed

3.4 coating
covering layer on the sight surface of a PVC-U profile, e.g. a co-extruded layer, a lacquer-coating or a laminated foil

3.5 laminated foil
plastic layer bonded with an adhesive or under pressure and temperature to cover a surface of a PVC-U profile

3.6 co-extrusion
durable bonding of two thermoplastics [e.g. unplasticized polyvinylchloride (PVC-U) and poly(methyl methacrylate) (PMMA)] that are melted in separated extruders and fused together in the profile tool

3.7 lacquer-coating
one or several layer(s) of lacquer (e.g. acrylic or polyurethane resin) or varnish (clear coating material) that cover(s) a PVC-U profile

3.8 radiant exposure
time integral of irradiance, measured in joules per square metre (J/m^{-2})

[ISO 9370:2009]

4 Designation of PVC-U profiles

The PVC-U profiles are designated in accordance with a classification system of their characteristics.

The designation consists of a description block and five data blocks as given in Table 1.

Table 1 — Designation of PVC-U profiles

Description block	Profile EN 13245-1
Data block 1: Material and profile type identification	PVC-U – Type 1, Type 2, Type 3 ^a or Type 4 ^a For types of profiles See 3.2
Data block 2: Intended application	One or more following codes depending on the intended application: For outside building applications: <i>E</i> For inside building applications: <i>I</i>
Data block 3: Material properties	Vicat softening temperature (VST): See 5.1 Modulus of elasticity in flexure: See 5.2
Data block 4: Profile properties	Nominal linear mass: See 5.3 Heat reversion at 100 °C: See 5.4 Impact resistance: See 5.5
Data block 5: Durability	See 5.6
^a For Type 3 or Type 4 profiles, the requirements given in 6.1 to 6.4 shall be fulfilled, as applicable.	

5 Codification system for Data block 3 to Data block 5

5.1 Vicat softening temperature (Data block 3)

The Vicat softening temperature (VST) shall be measured in accordance with EN ISO 306:2004, Method B50, using 4 mm thick test specimens, prepared according to EN ISO 1163-2, as indicated in Table 2.

Table 2 — Preparation of test specimens

Type of profile	Compound to be tested
Type 1	PVC-U compound
Type 2, Type 3 and Type 4	Each of the extruded compounds, as applicable

The value of VST shall be coded according to Table 3.

For Type 2, Type 3 and Type 4 profiles, as applicable, the values of the VST of each compound shall be coded from the internal layer to the external layer, with a separation by "/".

5.2 Modulus of elasticity in flexure (Data block 3)

The modulus of elasticity in flexure, *E*, shall be measured in accordance with EN ISO 178, using a 4 mm thick test specimens prepared according to EN ISO 1163-2, as indicated in Table 2.

For Type 2, Type 3 and Type 4 profiles, as applicable, the values of the modulus of elasticity in flexure of each compound shall be coded from the internal layer to the external layer, with a separation by "/".

The value of the modulus of elasticity in flexure shall be coded according to Table 3.

Table 3 — Codification for Data block 3

Vicat softening temperature (VST)	Modulus of elasticity in flexure, <i>E</i>	
	Range of values MPa	Code
The VST is represented by three figures giving the softening temperature. E.g. code 082 for a nominal VST value of 82 °C.	$1\ 700 \leq E < 2\ 000$	17
	$2\ 000 \leq E < 2\ 300$	20
	$2\ 300 \leq E < 2\ 600$	23
	$2\ 600 \leq E < 2\ 900$	26
	$2\ 900 \leq E < 3\ 200$	29
	$3\ 200 \leq E < 3\ 500$	32
	$(1\ 700 + 300 \times n) \leq E < (2\ 000 + 300 \times n)^a$	"(17 + 3 × <i>n</i>)"
^a <i>n</i> is an integer.		

5.3 Nominal linear mass (Data block 4)

The nominal linear mass of the PVC-U profile shall be measured in accordance with Annex A.

The value of the nominal linear mass shall be coded according to Table 4.

5.4 Heat reversion at 100 °C (Data block 4)

The heat reversion at 100 °C of the PVC-U profile, *R*, shall be measured in accordance with EN 479.

The value of the heat reversion at 100 °C shall be coded according to Table 4.

5.5 Impact resistance (Data block 4)

The impact resistance of the PVC-U profile at 23 °C or, if required, at a low temperature (0 °C, - 10 °C, - 20 °C or - *T*' °C), shall be measured in accordance with Annex B.

The value of the impact resistance shall be coded according to Table 4.

Table 4 — Codification for Data block 4

Nominal linear mass, P_M	Heat reversion at 100 °C		Impact resistance at T °C	
	R %	Code	Energy level J	Code
The nominal linear mass is represented by four figures giving the nominal linear mass. E.g. code 1483 for a nominal linear mass of 1 483 g/m.	$R \leq 2$	2	1	(T,01)
	$R \leq 3$	3	2	(T,02)
	$R \leq n^a$	n	3	(T,03)
			4	(T,04)
			5	(T,05)
			6	(T,06)
			10	(T,10)
			15	(T,15)
			20	(T,20)
			"(5 × m)" ^b	"[T,(5 × m)]"
^a n is an integer. ^b m is an integer.				

EXAMPLES

- Code (23,10) for a PVC-U profile with an impact resistance at 23 °C of 10 J;
- Code (-20,05) for a PVC-U profile with an impact resistance at - 20 °C of 5 J.

5.6 Durability (Data block 5)

5.6.1 General

Assessment of the durability is based on the following criteria:

- a) The colour differences between unexposed and exposed PVC-U profiles;
- b) The tensile-impact strength of the PVC-U profiles after ageing;
- c) The visual inspection of the PVC-U profiles after ageing;
- d) The adhesion of the coating of the PVC-U profiles after ageing (for Type 3 and Type 4 profiles, only).

5.6.2 Test methods for ageing

5.6.2.1 Outside building applications

Ageing shall be carried out according to either an artificial ageing test method or a natural ageing test method.

- a) Artificial ageing test method according to EN 513:1999, Method 1 (referring to EN ISO 4892-2:2006, Method A).

The conditions shall be defined in accordance with the code "A.n.T", where:

- 1) A means "artificial ageing";

- 2) n is the radiant exposure received by the exposed specimen, expressed in gigajoules per square metre, in the wavelength range 290 nm to 800 nm;
- 3) T is the black standard temperature (BST), if other than $(60 \pm 3) ^\circ\text{C}$, as specified in EN 513:1999.

EXAMPLE

- i) Codes A.8, A.12: a radiant exposure of 8 GJ/m² and 12 GJ/m² respectively, and a black standard temperature of 60 °C;
 - ii) Code A.8.55: a radiant exposure of 8 GJ/m² and a black standard temperature of 55 °C.
- b) Natural ageing test method, the conditions of exposure of which shall be defined in accordance with the code "N.n.T", where:
- 1) N means "natural ageing";
 - 2) n is the total solar radiant exposure received in gigajoules per square metre, measured on a plane at 45° to the horizontal facing the equator;
 - 3) T is the average temperature of the warmest month of the year on the exposure site.

NOTE For the assessment of solar irradiation conditions, it is recommended to refer to the WMO N° 8, 1996, *Guide to Meteorological Instruments and Methods of Observation*, Sixth edition [2].

EXAMPLE

Example for a two year exposure:

- i) South of France: code "N.12.23", for a total solar radiant exposure of 12 GJ/m² and an average temperature of 23 °C;
- ii) Florida: code "N.12.27", for a total solar radiant exposure of 12 GJ/m² and an average temperature of 27 °C;
- iii) Arizona: code "N.18.34", for a total solar radiant exposure of 18 GJ/m² and an average temperature of 34 °C.

5.6.2.2 Inside building applications

Ageing shall be carried out according to Method B of EN ISO 4892-2:2006 with the following conditions:

- Without spraying;
- Black-standard temperature (BST): $(60 \pm 3) ^\circ\text{C}$;
- Relative humidity: $(65 \pm 5) \%$.

The conditions shall be defined in accordance with the code "A.n", where:

- 1) A means "artificial ageing";
- 2) n is the radiant exposure received by the exposed specimen, expressed in gigajoules per square metre, in the wavelength range 300 nm to 800 nm.

5.6.3 Methods for assessing of ageing

5.6.3.1 Change in colour (or colour fastness)

The change in colour (or colour fastness) between the unexposed and exposed specimens shall be evaluated either by a visual assessment using the grey scale as specified in EN 20105-A02 or by a colorimetric measurement according to ISO 7724-1, ISO 7724-2 and ISO 7724-3.

5.6.3.2 Tensile-impact strength

The tensile-impact strength of the PVC-U profiles shall be measured on the exposed external wall of ten specimens in accordance with EN ISO 8256:2004, Method A, using test specimens of Type 5 cut in the extrusion direction.

5.6.3.3 Visual inspection

The appearance is determined by viewing by normal or corrected vision at a range of 1 m, in 45° north sky light perpendicular to the surface as specified in Clause 14 of EN ISO 105-A01:2010 or with an equivalent artificial source of light.

5.6.3.4 Adhesion of the coating

For Type 3 profiles, the peel strength of the exposed specimens shall be measured in accordance with Annex C. In the case where the peel test cannot be performed, then the adhesion of the foil shall be determined according to EN ISO 4624.

For Type 4 profiles, the adhesion of the lacquer-coating of the exposed specimens shall be measured in accordance with EN ISO 2409.

5.6.4 Codification for properties after ageing

For outside building applications, the PVC-U profiles shall be classified in accordance with Table 5, either from codes "A.2" to "A.*n*" after an artificial ageing, or from codes "N.0" to "N.*n*" after a natural ageing. Codes use increments of 2 GJ/m², according to the radiant exposure received during the exposure.

For inside building applications, the PVC-U profiles shall be classified in accordance with Table 5, either code "A.2" or code "A.0".

EN 13245-1:2010 (E)

Table 5 — Codification for Data block 5

Ageing conditions			Requirements							Codes	
Ageing	Radiant exposure	Temperature	Type 1, Type 2, Type 3 and Type 4				Type 3	Type 4			
			Tensile-impact strength		Change in colour ^a		Visual inspection	Adhesion of coating		Resistance to cross cut	
			Mean values kJ/m ²	Indiv. values kJ/m ²	either grey scale	or ΔE^*		Peel strength	Reduction of breaking strength		
EN ISO 8256		EN 20105-A02	ISO 7724 (all parts)	5.6.3.3	Annex C	EN ISO 4624	EN ISO 2409				
GJ/m ²		°C	-	-	-	N/mm	%	Class			
Profiles for outside building applications											
Artificial EN 513	<i>n</i> ^b	60	≥ 250	≥ 120	≥ 2	< 6,0	c	≥ 2,0	≤ 20	0	A. <i>n</i>
	<i>n</i> ^b	T	≥ 250	≥ 120	≥ 2	< 6,0	c	≥ 2,0	≤ 20	0	A. <i>n</i> .T
or											
Natural	<i>n</i> ^b	T	≥ 250	≥ 120	≥ 2/3	< 4,0	c	≥ 2,0	≤ 20	0	N. <i>n</i> .T
Profiles for inside building applications											
Artificial EN ISO 4892-2:2006, Method B	<i>n</i>	60	≥ 250	≥ 120	≥ 2	< 6,0	c	≥ 2,0	≤ 20	0	A. <i>n</i>
	0	-	No requirement								A.0
^a See 5.6.3.1. ^b <i>n</i> = 2, 4, 6, 8, ..., 20 GJ/m ² or more. ^c No bubbles/blistering, cracking or any signs of peeling, if relevant.											

6 Required characteristics for Type 3 and Type 4 profiles

6.1 Resistance to cross cut (only for Type 4 profiles)

The resistance to cross cut of the lacquer-coating shall be determined according to EN ISO 2409 and the test result shall not be higher than class 0.

6.2 Thermal resistance (only for Type 3 and Type 4 profiles)

The thermal resistance of the coating (laminated foil or lacquer-coating) shall be evaluated according to the test method specified in EN 478 with the following conditions:

- temperature of exposure: 70 °C;
- duration of exposure: 24 h.

After the exposure, the specimens shall be conditioned at room temperature for a minimum of 24 h before performing the visual inspection.

The visual inspection of the specimens shall not show any bubbles, blistering, cracking or any signs of peeling.

6.3 Water vapour resistance (only for Type 3 and Type 4 profiles, intended to be used for inside building applications)

The water vapour resistance of the coating (laminated foil or lacquer-coating) shall be evaluated according to the test method described in Clause 14 of EN 438-2:2005 with a duration of exposure of 1 h.

After testing, the specimens shall be conditioned at room temperature for a minimum of 24 h before performing the visual inspection.

The visual inspection of the specimens shall not show any bubbles, blistering, cracking or any signs of peeling.

6.4 Peel strength (only for Type 3 profiles)

The adhesion of the laminated foil to the substrate (PVC-U profile) shall be determined according to the peel test method specified in Annex C.

The peel strength values shall be greater or equal to 2,0 N/mm.

In the case where the peel test method according to Annex C cannot be carried out because of the type of foil, e.g. foil made from melamine material, the adhesion of the foil shall be determined according to EN ISO 4624 and the minimum value of the breaking strength shall be declared by the supplier.

7 Optional characteristics

7.1 Resistance to staining

Where required, the resistance to staining may be determined by applying the test method given in Clause 26 of EN 438-2:2005 or by applying the test method given in EN 12720 [3]. The staining agents and test conditions should be agreed between the supplier and the purchaser.

7.2 Appearance and finishing of the coating (only for Type 3 and Type 4 profiles)

7.2.1 General

Where required, the appearance and the finishing of the coating may be examined.

The coating shall be uniform and free from defects such as foreign bodies, cracks, sink marks, die lines, ripples, bulges, scratches or other surface defects when viewed by normal or corrected vision at a range of 1 m in 45° north sky light or with an equivalent artificial light source (approximately standard illuminate D65), viewing perpendicular to the surface as described in EN ISO 105-A01:2010.

When the colour of a profile is specified, the colorimetric coordinates, L^* , a^* and b^* , shall be determined in accordance with ISO 7724-1:1984, ISO 7724-2:1984 and ISO 7724-3:1984, using the test method D 65, SCI (specular reflectance included), 8/d or d/8.

7.2.2 Single colour profiles

The colour differences (ΔL^* , Δa^* , Δb^* , ΔE^*) between any profile and the manufacturer's stated reference colour shall be calculated according to ISO 7724-3 and shall not exceed the manufacturer's declared value.

7.2.3 Non-uniform colour and texture profiles

Reference samples of non-uniform colour and texture surface covered profiles shall be maintained demonstrating the extremes of permissible variation for comparison of the consistency of colour and appearance.

Applied textured surfaces shall have the pattern applied uniformly. Each textured surface shall match the reference sample when viewed by normal or corrected vision at a range of 1 m, in 45° north sky light or with an equivalent artificial light source (approximately standard illuminate D65), viewing perpendicular to the surface as described in EN ISO 105-A01:2010.

7.2.4 Gloss

When required, the gloss value of a profile's surface shall be measured according to EN ISO 2813 and declared by the manufacturer.

8 Example of the designation of a PVC-U profile

EXAMPLE A profile intended to be used for outside building applications made of PVC-U compound, with the following characteristics:

- Type 3 profile (laminated foil);
- Value for the Vicat softening temperature (VST) of the compound: 80 °C;
- Value for the modulus of elasticity in flexure of the compound: 2 700 MPa;
- Value of the nominal linear mass of the profile: 495 g/m;
- Value of the heat reversion at 100 °C: 2 %;
- Result of the impact resistance test method at 23 °C, with a striker mass of 500 g: (23,05);
- Result of the test methods after an exposure to artificial ageing, with a radiant exposure of 12 GJ/m² and a black standard temperature of 60 °C: pass;

- Result of the thermal resistance test: pass;
- Result of water vapour resistance test: pass;
- Result of the peel strength test: pass.

Description block	Data block 1	Data block 2	Data block 3	Data block 4	Data block 5
Profile EN 13245-1	PVC-U, Type 3	<i>E</i>	080,26	495,2,(23,05)	A.12

9 Use of reprocessable and recyclable material

Own and external reprocessable and recyclable material may be used for the manufacture of PVC-U profiles provided that the characteristics of the profiles conform to the requirements of the corresponding product specification, and any environmental legislation.

Annex A (normative)

Determination of the linear mass

A.1 Apparatus

A.1.1 **Balance**, with an accuracy of 0,1 g.

A.1.2 **Rule or measuring tape**, with an accuracy of 0,5 mm.

A.2 Test specimens

The length of the test specimen, measured between two cross sections cut perpendicularly to the main axis of the profile, shall be such that its mass is at least 50 g.

A.3 Procedure

Condition the profile before measuring for at least 1 h, at (23 ± 2) °C.

Measure the length, L , of the specimen, in metres, to 1 mm.

Measure the mass, M , of the specimen, in grams, to 0,2 g.

A.4 Calculation and expression of results

Calculate the linear mass of the profile, P , using Equation (A.1):

$$P = \frac{M}{L} \quad (\text{A.1})$$

where

P is the value of the linear mass of the profile, expressed in grams per metre;

M is the mass of the specimen;

L is the length of the specimen.

Calculate the tolerance, T , for the linear mass of the profile, using Equation (A.2):

$$T = \pm 0,4 P_M^{0,7} \quad (\text{A.2})$$

where

T is the tolerance for the linear mass of the profile;

P_M is the value of the nominal linear mass of the profile, as declared by the manufacturer, expressed in grams per metre.

Annex B (normative)

Determination of the impact resistance

B.1 Principle

The impact resistance of a PVC-U profile shall be measured at a specified temperature by striking the profile with a mass falling vertically from a known height onto the exposed surface, if any.

The energy levels shall be classified according to the results of a series of impact tests with a striker of specified mass.

B.2 Apparatus

B.2.1 Impact testing machine, as described in EN 477, with which the impact resistance test shall be carried out, incorporating the following equipment:

- a) Main frame, rigidly fixed in the vertical position;
- b) Guide rails or a guiding tube, rigidly fixed to the main frame to guide the striker and release it to fall vertically and freely;
- c) Rigid specimen support, comprising two rounded off steel supports (100 ± 1) mm apart [instead of (200 ± 1) mm according to EN 477:1995], rigidly fixed to a solid foundation or to a table having a mass of more than 50 kg;
- d) Release mechanism such that the striker can fall from a height which can be adjusted up to 1 500 mm, as measured from the top surface of the specimen;
- e) Striker, with a smooth hemispherical striking surface of ($25 \pm 0,5$) mm radius; the total mass of the striker shall be adjustable with relevant additional masses to the following masses: (100 ± 1) g, (200 ± 1) g, (300 ± 2) g, (400 ± 2) g, (500 ± 2) g, (600 ± 2) g, ($1\ 000 \pm 5$) g, ($1\ 500 \pm 5$) g, ($2\ 000 \pm 5$) g or ($m \times 100 \pm 5$) g where m is an integer.

B.3 Test specimens

Cut ten specimens, (200 ± 10) mm long, from PVC-U profiles selected at random from a batch.

In the case of PVC-U profiles with webs, choose the impact point approximately at the mid point between the supporting webs on the surface of the PVC-U profile normally exposed, if applicable.

If the geometry of the PVC-U profile does not allow determining clearly the impact point, the impact point and the method of installation of the specimen shall be recorded.

If the exposed and unexposed faces of the PVC-U profile are identical, mark each face and submit ten specimens to the impact resistance test on the external face.

B.4 Conditioning

B.4.1 Impact resistance at 23 °C

The specimens shall be conditioned at (23 ± 2) °C for at least 1 h before testing.

B.4.2 Impact resistance at low temperature

For the determination of the impact resistance at a low temperature, the specimens shall be conditioned at the relevant temperature before testing in a liquid bath or in a temperature controlled cabinet, as applicable, for a time period not less than the applicable period given in Table B.1.

The tolerance on the test temperature shall be ± 2 °C.

Table B.1 — Conditioning period according to the nominal linear mass

Nominal linear mass P_M g/m	Conditioning period	
	Liquid bath min	Air min
$P_M \leq 150$	15	60
$150 < P_M \leq 750$	30	120
$750 < P_M$	60	240

In case of dispute, a liquid bath for conditioning at 0 °C, and a controlled air cabinet for conditioning at - 10 °C, - 20 °C, or - T' °C, as applicable, shall be used.

B.5 Procedure

Submit each specimen to the following test:

- set down the specimen on the supports with the extrusion direction of the test specimen perpendicular to the two round steel supports and the determined impact point positioned vertically to the striker;
- set up the falling height at $(1\,000 \pm 5)$ mm from the top surface of the specimen and using adjustable masses;
- release the striker.

In the case of testing at a low temperature, each specimen shall be struck within the time interval of 10 s after removal from the conditioning environment. If that time interval is exceeded, the specimen shall be returned to the conditioning environment within 10 s, for a minimum period of 5 min. If the specimen is not returned to the conditioning environment within the 10 s after the time interval, it shall be discarded or fully reconditioned.

Examine the specimen and record the result as "Passed" or "Failed". Failure occurs when the impacted surface of the specimen splits or cracks. An unbroken dent of the impacted surface does not constitute failure.

In the case of a PVC-U profile with a top layer/coating (laminated foil, lacquer-coating, co-extruded layer), delaminating of the top layer shall also be considered as a failure.

B.6 Expression of results

The energy levels for the impact resistance according to the striker total mass are coded according to Table B.2.

For each energy level, the number of failures shall not be more than 1 out of 10 when the PVC-U profile is tested.

Table B.2 — Energy levels according to the striker total mass

Striker total mass	Energy level
g	J
100	01
200	02
300	03
400	04
500	05
600	06
1 000	10
1 500	15
2 000	20
"(500 × m)" ^a	"(5 × m)"
^a m is an integer.	

Annex C (normative)

Determination of peel strength

C.1 Principle

The test consists of subjecting the tear strip of the laminated foil of a profile, to a longitudinal force, perpendicular to the profile surface, either at a constant-speed or under a constant-load.

C.2 Apparatus

C.2.1 Peel strength apparatus, capable of applying a load to a tear strip of a laminated test piece, either by static masses or by tension at a constant-speed using a tensile testing machine, as shown in Figure C.1, or comparable.

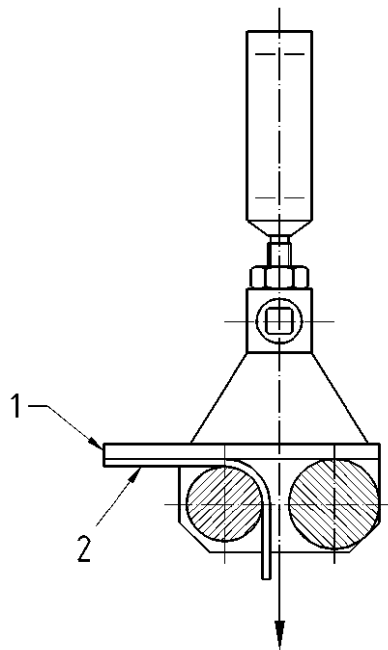

Key

- 1 profile test piece
- 2 laminated foil

Figure C.1 — Peel strength apparatus

C.3 Preparation of test pieces

Four test pieces either (20 ± 1) mm wide (for the constant-speed tensile test) or (25 ± 1) mm wide (for the constant-load tensile test) at least 100 mm long shall be cut from the sight surface of a profile with laminated foil. Notching along the cut edge shall be avoided.

The laminated foil (for clamping purposes) of approximately 50 mm long shall be separated from the substrate (PVC-U profile) by a suitable procedure. The same result may be achieved during lamination by inserting a contact blocking material (e.g. polyethylene foil) between the profile and the laminated foil.

If only finished PVC-U profiles with laminated foil are available, the test pieces shall be prepared as follows:

- a) Cut the sight surface of the profile from the core over the entire width of the profile. Cut the separated sight surface into 200 mm long test pieces.
- b) Place either a (200 ± 2) mm \times (20 ± 1) mm metal template (for the constant-speed tensile test) or a (200 ± 2) mm \times (25 ± 1) mm metal template (for the constant-load tensile test) lengthways on the sight surface of the test piece, midway between the sides.
- c) Using a blade, cut through the laminated foil along the long sides of the template.
- d) Mill away the back wall of the profile surface to a thickness of 0,5 mm along a line midway between the test piece short sides and transverse to its longitudinal axis. Be careful not to cut into the PVC-U substrate too deep so as to avoid damaging the laminated foil. Then mill away (also to a thickness of 0,5 mm) the entire back wall of the test piece along the two lines cut in the laminated foil from one end of the test piece as far as the transverse line. Break off the material on either of the $100 \text{ mm} \times 20 \text{ mm}$ (for the constant-speed tensile test) or $100 \text{ mm} \times 25 \text{ mm}$ (for the constant-load tensile test) milled by gently bending the test piece.

C.4 Conditioning

Condition the test pieces for a minimum of 72 h after lamination, at (23 ± 5) °C.

The test pieces shall not be tested within 72 h after lamination.

C.5 Procedure

C.5.1 Constant-speed tensile test

Carry out testing at (23 ± 5) °C the following procedure:

- a) set up the test piece (20 ± 1) mm wide in the peel strength apparatus and connect the laminated foil to the jaw such that the load is applied perpendicular to the main axis of the profile;
- b) extend the test piece by applying a rate of displacement of the driven grip of the test machine of (10 ± 1) mm/min.

If the foil breaks before peeling occurs, the tensile strength at break of the foil shall be reported.

The test results shall be expressed in newtons per millimetre.

For the determination of the peel strength after ageing, the constant-speed tensile test shall be used if it is used for testing non-aged profiles.

C.5.2 Constant-load tensile test

Carry out testing at (23 ± 5) °C the following procedure:

- a) set up the test piece (25 ± 1) mm wide in the peel strength apparatus, supported by free running rollers and connect the laminated foil to the jaw such that the load is applied perpendicular to the main axis of the profile;
- b) apply smoothly during one minute to the test piece a constant load of $(5 \pm 0,01)$ kg (i.e. 2,0 N/mm), either by slowly releasing the load or by gradually applying the equivalent force by means of the tensile testing machine.

Measure the peeled length occurring between the foil and the profile either before the foil stretches and shears or when the constant load is applied.

There shall be no more than 25 mm of peeling.

For the determination of the peel strength after ageing, the constant-load tensile test shall be used if it is used for testing non-aged profiles.

C.6 Test report

The test report shall include the following information:

- a) Reference to EN 13245-1:2010, Annex C;
- b) All details necessary for complete identification of the test pieces;
- c) Number of test pieces;
- d) Width of the test pieces, in millimetres;
- e) Test method used [constant-speed tensile test (C.5.1) or constant-load tensile test (C.5.2)];
- f) Type of separation of the laminated foil;
- g) Result of the constant-speed tensile test (C.5.1);
 - 1) Individual peel strength values in newtons per millimetre;
 - 2) If the foil breaks, the tensile strength at break of the foil in newtons;
- h) Result of the constant-load tensile test (C.5.2):
 - 1) Peeled length in millimetres;
- i) Any factors which may have affected the results, such as any incidents or any operating details not specified in this annex;
- j) Date of the test.

Bibliography

- [1] ISO 9370:2009, *Plastics — Instrumental determination of radiant exposure in weathering tests — General guidance and basic test method*
- [2] WMO N° 8,1996, *Guide to meteorological instruments and methods of observation*, Sixth edition, World Meteorological Organisation, Geneva
- [3] EN 12720, *Furniture — Assessment of surface resistance to cold liquids*

.....

British Standards Institution (BSI)

BSI is the independent national body responsible for preparing British Standards and other standards-related publications, information and services.

It presents the UK view on standards in Europe and at the international level.

It is incorporated by Royal Charter.

Revisions

British Standards are updated by amendment or revision. Users of British Standards should make sure that they possess the latest amendments or editions.

It is the constant aim of BSI to improve the quality of our products and services. We would be grateful if anyone finding an inaccuracy or ambiguity while using this British Standard would inform the Secretary of the technical committee responsible, the identity of which can be found on the inside front cover.

Tel: +44 (0)20 8996 9001 Fax: +44 (0)20 8996 7001

BSI offers Members an individual updating service called PLUS which ensures that subscribers automatically receive the latest editions of standards.

Tel: +44 (0)20 8996 7669 Fax: +44 (0)20 8996 7001

Email: plus@bsigroup.com

Buying standards

You may buy PDF and hard copy versions of standards directly using a credit card from the BSI Shop on the website www.bsigroup.com/shop. In addition all orders for BSI, international and foreign standards publications can be addressed to BSI Customer Services.

Tel: +44 (0)20 8996 9001 Fax: +44 (0)20 8996 7001

Email: orders@bsigroup.com

In response to orders for international standards, it is BSI policy to supply the BSI implementation of those that have been published as British Standards, unless otherwise requested.

Information on standards

BSI provides a wide range of information on national, European and international standards through its Knowledge Centre.

Tel: +44 (0)20 8996 7004 Fax: +44 (0)20 8996 7005

Email: knowledgecentre@bsigroup.com

Various BSI electronic information services are also available which give details on all its products and services.

Tel: +44 (0)20 8996 7111 Fax: +44 (0)20 8996 7048

Email: info@bsigroup.com

BSI Subscribing Members are kept up to date with standards developments and receive substantial discounts on the purchase price of standards. For details of these and other benefits contact Membership Administration.

Tel: +44 (0)20 8996 7002 Fax: +44 (0)20 8996 7001

Email: membership@bsigroup.com

Information regarding online access to British Standards via British Standards Online can be found at www.bsigroup.com/BSOL

Further information about BSI is available on the BSI website at www.bsigroup.com/standards

Copyright

Copyright subsists in all BSI publications. BSI also holds the copyright, in the UK, of the publications of the international standardization bodies. Except as permitted under the Copyright, Designs and Patents Act 1988 no extract may be reproduced, stored in a retrieval system or transmitted in any form or by any means – electronic, photocopying, recording or otherwise – without prior written permission from BSI. This does not preclude the free use, in the course of implementing the standard of necessary details such as symbols, and size, type or grade designations. If these details are to be used for any other purpose than implementation then the prior written permission of BSI must be obtained. Details and advice can be obtained from the Copyright & Licensing Manager.

Tel: +44 (0)20 8996 7070

Email: copyright@bsigroup.com

BSI Group Headquarters

389 Chiswick High Road London W4 4AL UK

Tel +44 (0)20 8996 9001

Fax +44 (0)20 8996 7001

www.bsigroup.com/standards

raising standards worldwide™