

Child use and care articles — Baby carriers — Safety requirements and test methods —

Part 1: Framed back carriers

The European Standard EN 13209-1:2004 has the status of a
British Standard

ICS 97.190

National foreword

This British Standard is the official English language version of EN 13209-1:2004.

The UK participation in its preparation was entrusted to Technical Committee CW/41, Child use and care articles, which has the responsibility to:

- aid enquirers to understand the text;
- present to the responsible international/European committee any enquiries on the interpretation, or proposals for change, and keep the UK interests informed;
- monitor related international and European developments and promulgate them in the UK.

A list of organizations represented on this committee can be obtained on request to its secretary.

Cross-references

The British Standards which implement international or European publications referred to in this document may be found in the *BSI Catalogue* under the section entitled “International Standards Correspondence Index”, or by using the “Search” facility of the *BSI Electronic Catalogue* or of British Standards Online.

This publication does not purport to include all the necessary provisions of a contract. Users are responsible for its correct application.

Compliance with a British Standard does not of itself confer immunity from legal obligations.

This British Standard was published under the authority of the Standards Policy and Strategy Committee on 30 November 2004

Summary of pages

This document comprises a front cover, an inside front cover, the EN title page, pages 2 to 22, an inside back cover and a back cover.

The BSI copyright notice displayed in this document indicates when the document was last issued.

Amendments issued since publication

Amd. No.	Date	Comments

© BSI 30 November 2004

ISBN 0 580 44915 7

ICS 97.190

English version

Child use and care articles - Baby carriers - Safety requirements
and test methods - Part 1: Framed back carriers

Articles de puériculture - Porte-enfants - Exigences de
sécurité et méthodes d'essai - Partie 1 : Porte-enfants
dorsaux avec armature

Artikel für Säuglinge und Kleinkinder - Kindertragen -
Sicherheitstechnische Anforderungen und Prüfverfahren -
Teil 1: Rückentragen mit Gestell

This European Standard was approved by CEN on 22 July 2004.

CEN members are bound to comply with the CEN/CENELEC Internal Regulations which stipulate the conditions for giving this European Standard the status of a national standard without any alteration. Up-to-date lists and bibliographical references concerning such national standards may be obtained on application to the Central Secretariat or to any CEN member.

This European Standard exists in three official versions (English, French, German). A version in any other language made by translation under the responsibility of a CEN member into its own language and notified to the Central Secretariat has the same status as the official versions.

CEN members are the national standards bodies of Austria, Belgium, Cyprus, Czech Republic, Denmark, Estonia, Finland, France, Germany, Greece, Hungary, Iceland, Ireland, Italy, Latvia, Lithuania, Luxembourg, Malta, Netherlands, Norway, Poland, Portugal, Slovakia, Slovenia, Spain, Sweden, Switzerland and United Kingdom.



EUROPEAN COMMITTEE FOR STANDARDIZATION
COMITÉ EUROPÉEN DE NORMALISATION
EUROPÄISCHES KOMITEE FÜR NORMUNG

Management Centre: rue de Stassart, 36 B-1050 Brussels

Contents

page

Foreword.....	4
1 Scope	5
2 Normative references	5
3 Terms and definitions	5
4 General requirements and conditioning	5
4.1 Multi – purpose products	5
4.2 Order of tests	5
4.3 Tolerances	6
5 Materials	6
5.1 Chemical properties	6
5.2 Flammability of textiles, coated textiles, supports and plastic coverings	6
5.3 Conditioning	6
5.4 Shrinkage	7
5.5 Monofilament threads	7
6 Construction	7
6.1 Gaps and openings	7
6.2 Edges	7
6.3 Small parts	8
6.3.1 Requirements	8
6.3.2 Test method	8
6.4 Cords, straps, belts and parts used as ties	9
6.5 Folding and locking mechanisms	9
6.5.1 Durability of folding and locking mechanisms	9
6.5.2 Requirement	9
6.5.3 Moving parts	10
6.5.4 Incomplete deployment	10
6.6 Accessibility of fillings	10
6.6.1 Requirement	10
6.6.2 Test equipment	10
6.6.3 Test procedure	12
6.7 Stability	13
6.7.1 Requirements	13
6.7.2 Test	13
6.8 Carer attachment systems	13
6.8.1 General	13
6.8.2 Dimensions	13
6.8.3 Effectiveness of adjustment devices	13
6.8.4 Durability of attachment system	13
6.9 Dynamic strength	13
6.9.1 Requirement	13
6.9.2 Test apparatus	14
6.9.3 Test mass	15
6.9.4 Test procedure	15
6.10 Child restraint system	16
6.10.1 Requirements	16
6.10.2 Test equipment	16
6.10.3 Test methodology	17
7 Packaging	18

8	Marking	18
8.1	General	18
8.2	Labels on product	19
8.3	Durability of marking	19
9	Instructions for use	19
Annex A (informative)		21
Bibliography		22

Foreword

This document (EN 13209-1:2004) has been prepared by Technical Committee CEN/TC 252 "Child use and care articles", the secretariat of which is held by AFNOR.

This European Standard shall be given the status of a national standard, either by publication of an identical text or by endorsement, at the latest by March 2005, and conflicting national standards shall be withdrawn at the latest by March 2005.

This document includes a Bibliography.

According to the CEN/CENELEC Internal Regulations, the national standards organizations of the following countries are bound to implement this European Standard: Austria, Belgium, Cyprus, Czech Republic, Denmark, Estonia, Finland, France, Germany, Greece, Hungary, Iceland, Ireland, Italy, Latvia, Lithuania, Luxembourg, Malta, Netherlands, Norway, Poland, Portugal, Slovakia, Slovenia, Spain, Sweden, Switzerland and United Kingdom.

1 Scope

This document specifies the safety requirements and test methods for child back carriers with framed support. These framed carriers are intended for children who can sit unaided (approximately 6 months of age) and are designed to be attached to a carer's torso allowing a "hands free operation" when standing and/or walking.

2 Normative references

The following referenced documents are indispensable for the application of this document. For dated references, only the edition cited applies. For undated references, the latest edition of the referenced document (including any amendments) applies.

EN 71-1, *Safety of toys - Part 1: Mechanical and physical properties.*

EN 71-2, *Safety of toys - Part 2: Flammability.*

EN 71-3, *Safety of toys - Part 3: Migration of certain elements.*

3 Terms and definitions

For the purposes of this document, the following terms and definitions apply.

3.1

carer's attachment system

fastenings, straps and/or belts which are fitted to the framed carrier for the purpose of securing the article to the carer's torso

3.2

child restraint system

assembly of fastening straps and/or a belt that is fitted to the framed carrier in order to restrain the child within the carrier

3.3

freestanding carriers

carrier designed with a system that allows it to stand unsupported prior to the child being placed in the carrier

4 General requirements and conditioning

4.1 Multi – purpose products

If a carrier has other functions not covered in this standard, reference should be made to the relevant standard e.g. child wheeled conveyance (see EN 1888).

4.2 Order of tests

Unless specified the order of testing shall be carried out in the order of the clause numbers of this document.

Additional samples may be used when doing the following tests:

5.1 Chemical properties

5.2 Flammability of textiles

6.6 Accessibility of fillings

4.3 Tolerances

Unless otherwise stated the following tolerances shall apply for testing and test equipment.

All forces shall have an accuracy of $\pm 5\%$.

All masses shall have an accuracy of $\pm 1\%$.

All dimensions shall have an accuracy of $\pm 1\text{ mm}$.

All time measurements shall have an accuracy of $\pm 1\text{ s}$.

All angles shall have an accuracy of $\pm 1^\circ$.

5 Materials

5.1 Chemical properties

The migration of synthetic or natural elements: coating of paint, varnish, lacquer, printing ink, polymer and similar coatings, the other materials whether mass coloured or not shall comply with the following amounts.

Antimony	:	60 mg/kg
Arsenic	:	25 mg/kg
Barium	:	1 000 mg/kg
Cadmium	:	75 mg/kg
Chromium	:	60 mg/kg
Lead	:	90 mg/kg
Mercury	:	60 mg/kg
Selenium	:	500 mg/kg

These limits shall be checked according to the test prescribed in EN 71-3.

Where a surface coated with a multi-layer of paint or similar coating, the sample shall not include the substrate.

5.2 Flammability of textiles, coated textiles, supports and plastic coverings

The rate of the spread of flame shall not exceed 30 mm/s when tested in accordance with EN 71-2.

5.3 Conditioning

Any parts which are intended to be removed from the structure, shall be washed/dried or cleaned twice according to the manufacturer's instructions.

5.4 Shrinkage

After testing in accordance with 5.3 any resulting shrinkage shall not prevent the covering from being refitted to the structure, without damaging the seams of the fabric and shall not impair the performance and use of the article.

5.5 Monofilament threads

Monofilament threads shall not be used.

6 Construction

6.1 Gaps and openings

There shall be no open-ended tubes, projections, holes or loose washers, speed fixings, nuts or crevices in which the child's finger or flesh could become trapped.

When the carrier is assembled for use in any configuration, there shall be no gaps and openings greater than 5 mm and less than 12 mm, unless the depth of penetration is less than 10 mm.

Buckles, fastenings and sliders are excluded from this requirement.

6.2 Edges

In order to avoid lacerations or abrasions, the surfaces shall be smooth and free from splinters and burrs.

Edges or components with a thickness greater than 4 mm and an internal angle of less than 120° shall have a 2 mm radius or be chamfered as given in the examples in Figure 1a) b) and c).

Edges or components with a thickness less than 4 mm shall be rounded, folded, rolled or spiralled (as given in the example in Figure 1d); or have a protective covering as given in the example in Figure 1e).

The minimum radii do not apply to small components such as hinges, brackets and catches but these shall be free of burrs and sharp edges and points.

Any protective covering applied in order to meet the above specifications shall comply with the requirements for protective components specified in EN 71-1.

Dimensions in millimetres

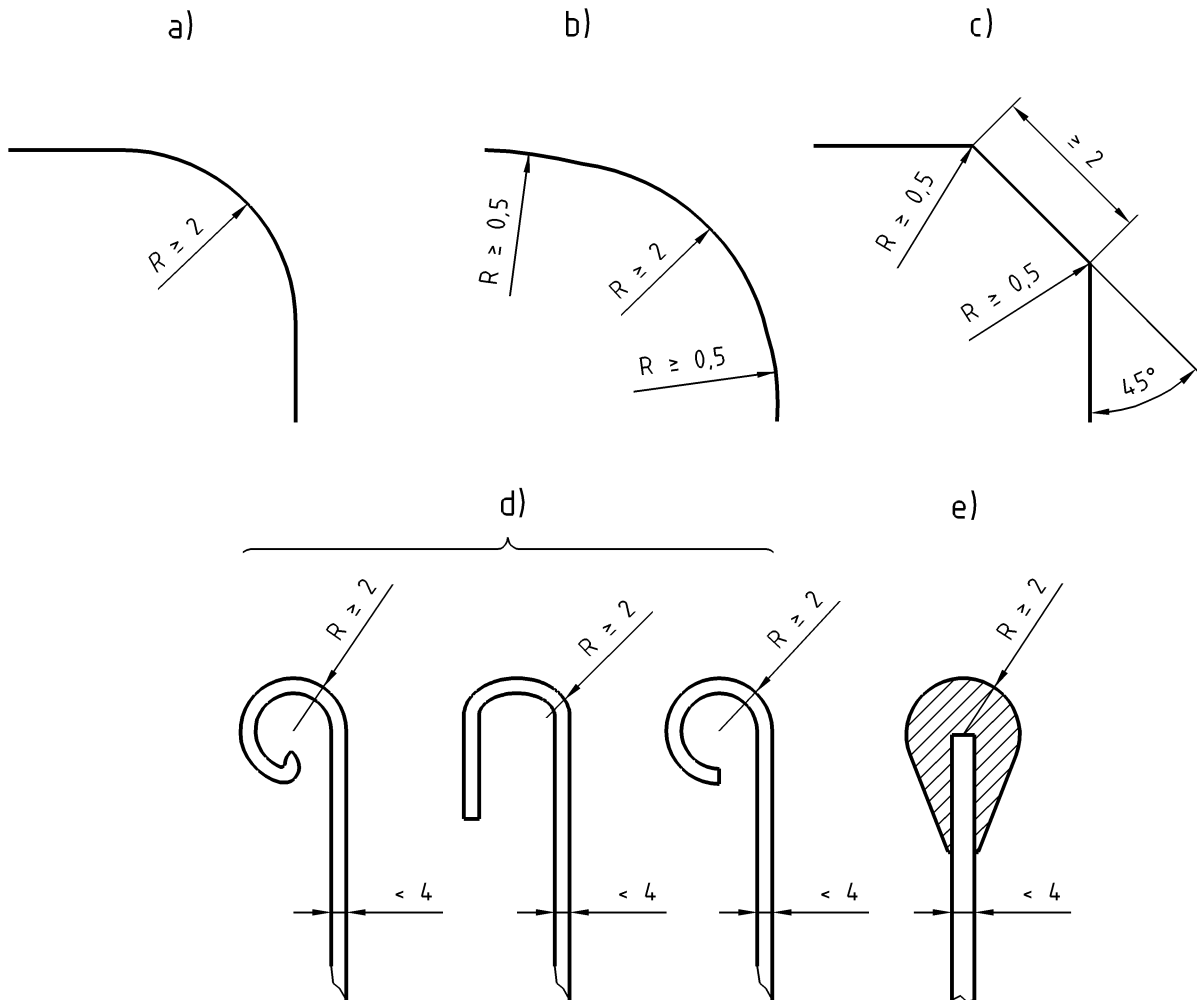

Figure 1 — Examples for minimum radii of edges and corners

6.3 Small parts

6.3.1 Requirements

Any components not intended to be detachable, which become detached when tested in accordance with 6.3.2.2 and 6.3.2.3 shall not, fit wholly within the small parts cylinder specified in EN 71-1.

Any component intended to be removable without the use of a tool shall not fit wholly within the small parts cylinder as specified in EN 71-1.

6.3.2 Test method

6.3.2.1 Apparatus

Means of applying forces up to at least 90 N with an accuracy of ± 2 N, e.g. a spring balance or a dead weight arrangement.

Feeler gauge with thickness of $(0,4 \pm 0,02)$ mm, with the end to be inserted having a radius of approximately 3 mm.

6.3.2.2 Tension test

Establish if the component to be tested is grippable by inserting the feeler gauge between the component and the underlying layer or body of the item at an angle between 0° and 10° from the surface using a force of (10 ± 1) N. If the gauge can be inserted more than 2 mm the component is to be judged grippable.

If the component is grippable, affix a suitable clamp behind the component taking care not to damage the attachment mechanism or body of the item.

Apply a tensile force to the component to be tested through a clamp or by other suitable means apply a force of 90 N gradually over 5 s and maintain for 10 s.

6.3.2.3 Torque test

If the component can be gripped between thumb and forefinger, apply a torque gradually to the component within a period of 5 s in a clockwise direction until either a rotation of 180° from the original position has been obtained, or a torque of 0,34 Nm is reached. Maintain the maximum rotation or required torques for 10 s. Permit the test component to return to a relaxed condition. Repeat this procedure in an anti-clockwise direction.

Projections, parts or assemblies that are rigidly mounted on an accessible rod or shaft designed to rotate together with the projections, parts or assemblies shall be tested with the rod or shaft clamped to prevent rotation.

If a component, which is attached by a screw, becomes loosened during the application of the required torque, continue to apply the torque until the required torque is exceeded or the part disassembles or it becomes apparent that the part will not disassemble.

6.4 Cords, straps, belts and parts used as ties

Cords, straps, belts and parts used as ties shall have a maximum free length of 220 mm when stretched with a force of 25 N.

This requirement does not apply to the free ends of the carer's attachment systems and the child restraint systems.

6.5 Folding and locking mechanisms

6.5.1 Durability of folding and locking mechanisms

Locking and folding mechanisms shall continue to meet the requirements of 6.5.2 after being opened and closed 300 times.

6.5.2 Requirement

Folding or locking mechanisms, shall be considered inoperable by a child if at least one of the following conditions is fulfilled:

- folding or locking is only possible when two independent locking mechanisms are operated simultaneously; or
- release of the folding or locking mechanism requires a specified minimum force of 50 N or the use of a tool (e.g. spanner or screwdriver); or
- release of the folding or locking mechanism requires two consecutive actions, the first of which shall be maintained while the second is carried out; or

- when tested with only the automatic locking mechanism(s) engaged, the application of a force of 200 N to any part of the product (except the locking release mechanism) does not result in folding or detachment.

6.5.3 Moving parts

- a) There shall be no compression points which can close to less than 18 mm under the action of forces other than those of the carer setting up or folding away (e.g. spring force or gravity), unless the clearance is always less than 5 mm.
- b) Compression points which can close to less than 12 mm that only become accessible as the product is set up or folded away are allowable. Contact edges and ends shall comply with 6.2 unless the clearance is always less than 5 mm. When compression points prohibited by a) would be created by the release of locking mechanisms, or by a user wrongly believing that a carrier is ready for use without the locking mechanisms fully engaged, then these locking mechanisms shall meet the requirements of 6.5.1.

NOTE The requirements of this clause do not apply to supported structures e.g. hoods and canopies.

6.5.4 Incomplete deployment

Where, it is possible for a carer to wrongly believe that a carrier is ready for use without the locking mechanism fully engaged (i.e. incomplete deployment), folding or detachment shall be prevented by either:

- the weight of the child using the article acting to prevent the folding or detachment; or
- at least one locking mechanism engaging automatically when the article is deployed for use.

6.6 Accessibility of fillings

6.6.1 Requirement

No filling should be released from the product when tested in accordance with 6.6.3.

6.6.2 Test equipment

The device (see Figure 2) shall consist of two sets of teeth (see Figure 3) made from H13 high chrome tool steel or equivalent and hardened to 45/50 Rockwell. Two at the top and two at the bottom, positioned so that the vertical centre line of one pair of teeth is $(1 \pm 0,1)$ mm in front of the centre line of the other set of teeth. In the fully closed position the teeth shall overlap each other by $(1 \pm 0,1)$ mm. The outer most corners of the teeth shall have a radius of $(0,3 \pm 0,1)$ mm.

The teeth shall be mounted so as to pivot about a point (50 ± 1) mm from the rear most pair of teeth and positioned so that when closed the centre lines of the two pairs of teeth are parallel to each other. The device shall be equipped with a stop to prevent the distance between the teeth from exceeding 28 mm when fully opened. The closing force of the teeth shall be set at (50 ± 5) N.

The device shall be provided with a guide to prevent items entering further into the fully opened jaws by more than 17 mm. The device shall be equipped with a means whereby a force of (50 ± 5) N may be applied along its centre line in a direction tending to pull the teeth off the sample.

Dimensions in millimetres

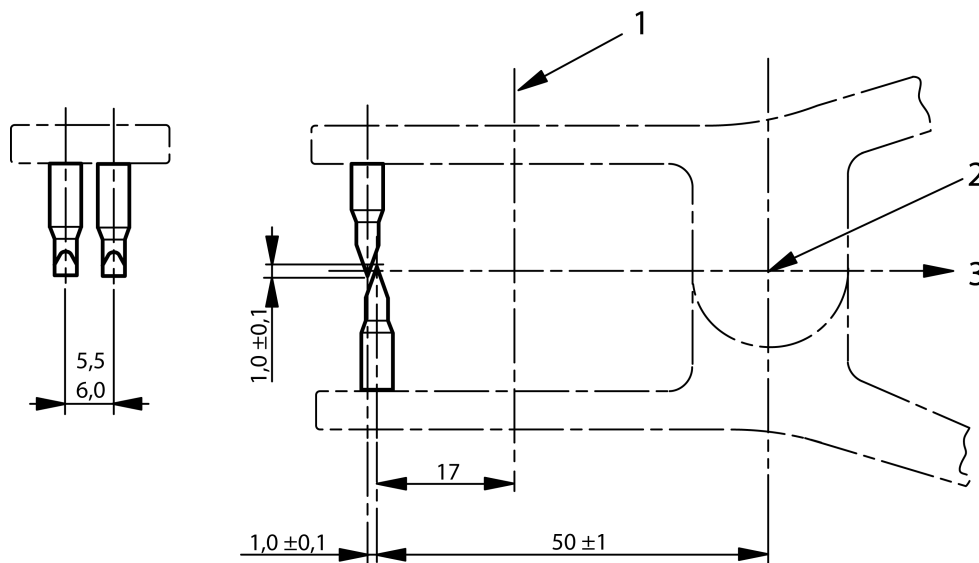
**Key**

- 1 Position of guide
- 2 Pivot point
- 3 Force = 50 N

Figure 2 — Test device

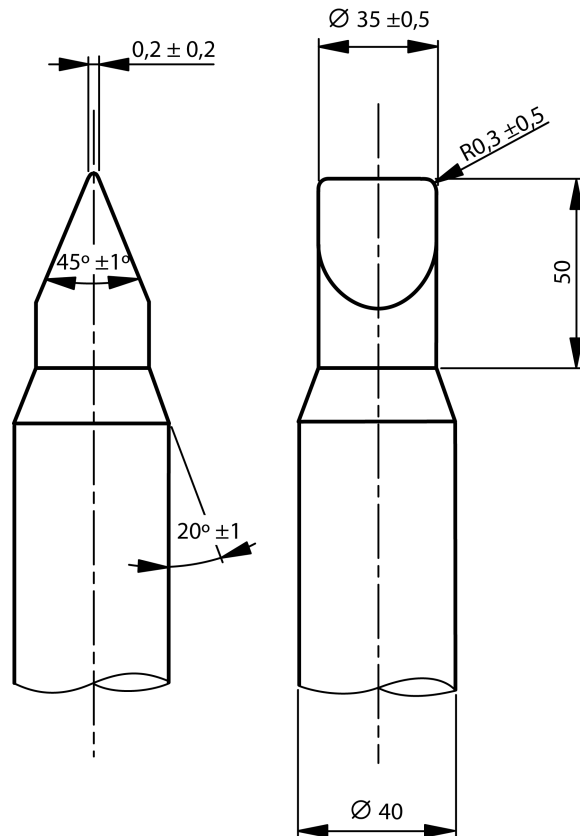

Figure 3 — Test teeth

6.6.3 Test procedure

Apply the test device twice as follows on any two positions:

- pinch the materials between finger and thumb and attach the test device so as to “bite” the smallest amount of materials possible to allow contact with all four teeth and apply a pulling force of 50 N, maintaining it for 10 s, to the device; then open the jaws of the test device as far as possible and push it onto the material as far as the guide, allow the teeth to close on the material and apply a pulling force of 50 N, maintaining it for 10 s, to the device;
- if, during the test procedure, the outer material is punctured by the teeth, remove the outer material to expose the layer below or the filling and repeat the procedure at a) and b) until the filling cannot be reached or no filling becomes detached. As soon as any filling becomes detached stop the test.

A puncture is defined as occurring when at least one tooth of the bite tester has broken the textile or plastic material to which it is being applied, the tooth passing through the entire thickness of the material. Where the bite tester is applied to materials of a loose weave or open mesh, a puncture is defined as occurring when part of the weave or mesh is broken by at least one of the teeth of the bite tester. Should the teeth of the bite tester pass through materials of a loose weave or open mesh without damaging the material, a puncture has not occurred.

6.7 Stability

6.7.1 Requirements

The freestanding carriers shall not tip over when tested in accordance with 6.7.2.

6.7.2 Test

6.7.2.1 Apparatus

Platform inclined to an angle of 12° to the horizontal and covered with aluminium oxide paper of grade 80. Platform is fitted with rectangular stops of 20 mm in height at the base of the platform.

6.7.2.2 Test method

Place the test mass 6.9.3 in the carrier, then place the carrier on the platform in the following positions with the lowest part of the frame resting against the stops:

- a) facing forward;
- b) facing rearwards;
- c) at right angles to the slope.

If necessary, use wedges of a negligible mass to prevent movement of the test mass.

6.8 Carer attachment systems

6.8.1 General

The carer's attachment system shall be adjustable.

6.8.2 Dimensions

Waist belt and shoulder straps of the carer attachment system shall have a minimum width of 40 mm wide.

6.8.3 Effectiveness of adjustment devices

When tested in accordance with 6.9.4 the maximum slippage of any straps shall be 20 mm.

6.8.4 Durability of attachment system

When tested in accordance with 6.9.4 the mechanisms of the carer's attachment system shall not be released and shall continue to function as intended.

6.9 Dynamic strength

6.9.1 Requirement

After 50 000 cycles of the dynamic strength test as specified in 6.9.4 the carrier shall have no visual damage that will impair its function.

NOTE The strength of the framed carrier is tested by reproducing the stresses that would be subjected to the carrier in a walk of approximately 30 km under severe conditions.

6.9.2 Test apparatus

A rigid test torso with dimensions as specified in Figure 4 fitted on a rigid plate. The plate shall be submitted to an alternating vertical sinusoidal movement with an amplitude of 120 mm (± 5 mm) and a frequency of 2 Hz (± 10 %).

Dimensions in millimetres

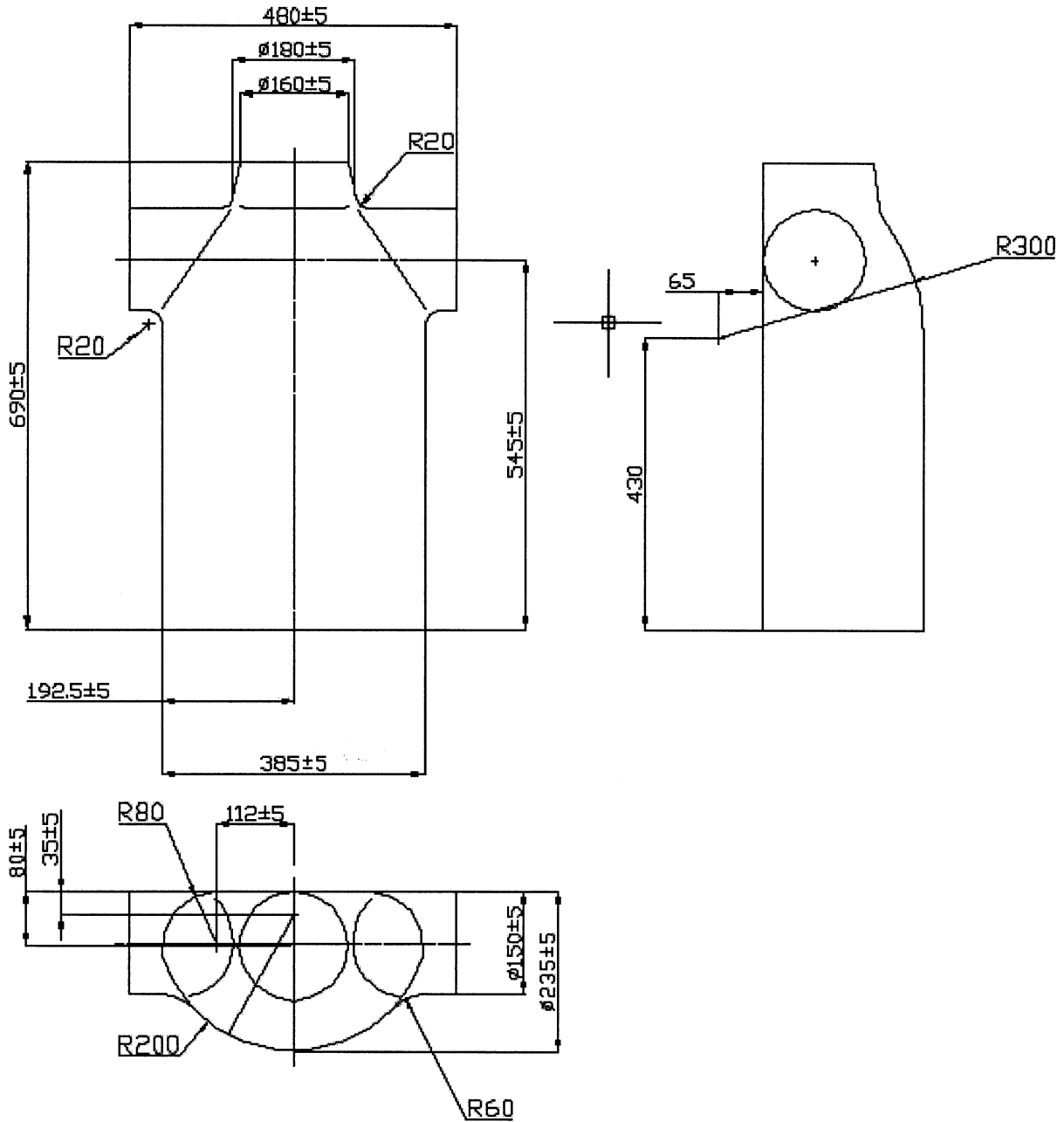

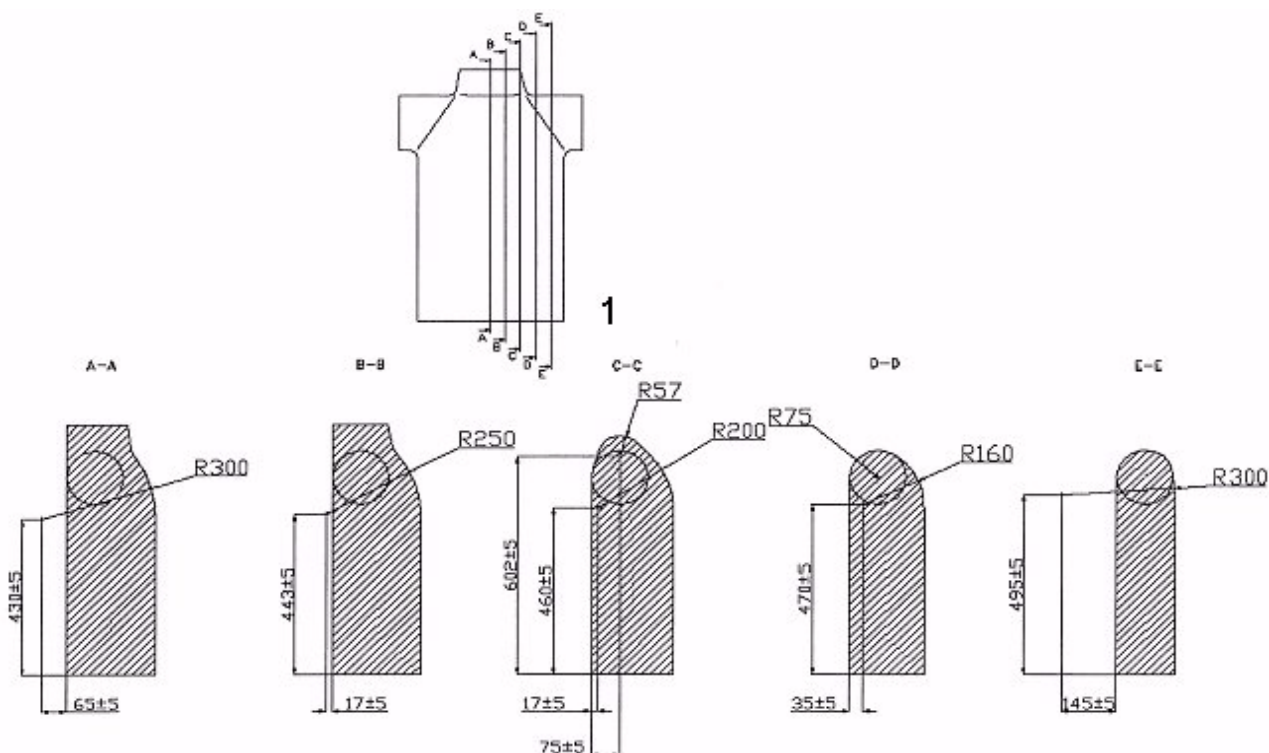

Key

- 1 Section every 40 mm

Figure 4 — Test torso

6.9.3 Test mass

A 230 mm diameter bag filled with sand ($= 1,45 \text{ g/cm}^3$) with a total mass of 15 kg. If the maximum recommended weight of the child specified by the manufacturer is greater than 15 kg then this specified maximum weight shall be used.

6.9.4 Test procedure

Place the carrier on the test torso 6.9.2 and adjust to fit the test torso in accordance with the manufacturer's instructions. Place the test mass 6.9.3 in the carrier and adjust all straps so that the test mass is firmly restrained.

Using the test apparatus as described in 6.9.2 carry out the test for 10 cycles. Mark carer's attachment straps to enable measurement of any slippage of straps, buckles or other devices.

Carry out the test for a further 90 cycles and measure any slippage of the straps of the carer's attachment system (requirement 6.9.1).

Carry out the test for a further 49 900 cycles (requirement 6.9.1).

6.10 Child restraint system

6.10.1 Requirements

The carrier shall be fitted with a child restraint system.

The restraint system shall be adjustable.

Any crotch restraint shall be capable of being used in combination with other parts of the restraint system.

Straps used for a child's restraint system shall have a minimum width of 20 mm.

When tested in accordance with 6.10.3.1, test dummy shall not completely fall out of the restraint system. It shall be noted that any partial movement of test dummy is not considered a failure.

When tested in accordance with 6.10.3.1, the attachment of the restraint system shall not break, deform, work loose or become torn/displaced.

When tested in accordance with 6.10.3.2 in any orientation, fasteners shall not be released or have suffered damage which impairs their operation and function.

When tested in accordance with 6.10.3.3 the maximum slippage of adjusters shall be 20 mm.

Instructions shall be provided for the use of the restraint system.

6.10.2 Test equipment

Test dummy made of a rigid material with a smooth finish and a total mass of $(9 \pm 0,1)$ kg, see Figure 5.

Dimensions in millimetres

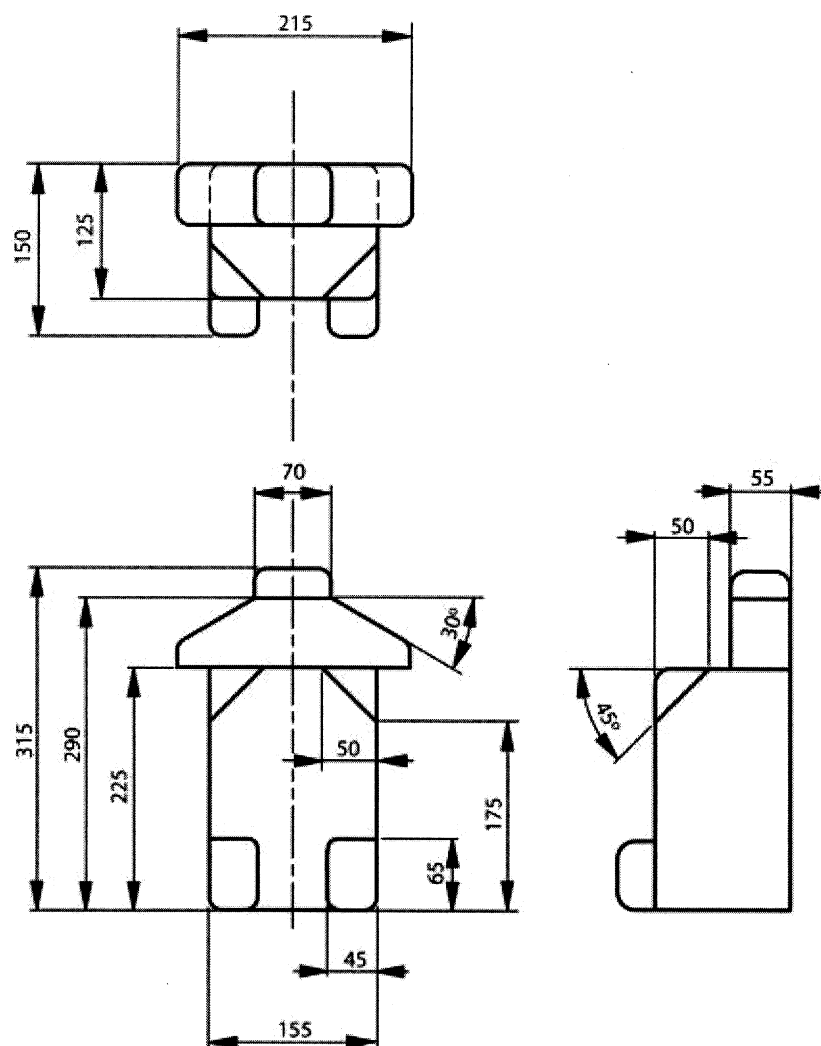

Figure 5 — Test dummy

6.10.3 Test methodology

6.10.3.1 Effectiveness of restraint system

Initially place the test dummy centrally in the seat and attach the restraint system in accordance with the manufacturers instructions. Fasten any waist restraint around the torso section of the test dummy so that any slackness is removed and the waist restraint is positioned above the leg stumps. If the crotch restraint is adjustable, adjust it so that any slackness is removed. Where shoulder straps are fitted, place a 30 mm cuboid spacer block, made of a hard smooth material, on each shoulder of the test dummy. Adjust each shoulder strap so that any slackness is removed. Remove the spacers.

A means of rotation is used to rotate the product smoothly through 360° at a speed of $(4 \pm 0,5)$ r/min in a forward and reverse direction.

Rotate the product through 360° in a forward direction. If necessary reposition the test dummy to its initial position without altering the adjusters on the restraint system. Rotate the product through 360° in the reverse

direction. If necessary reposition the test dummy to its initial position without altering the adjusters on the restraint system.

Repeat the forward and reverse rotation cycles for two more sequences, giving a total of 3 forward and 3 reverse rotations. If necessary, after each rotation, reposition the test dummy to its initial position without altering the adjusters on the restraint system.

6.10.3.2 Strength of fastener

A tensile force of 200 N should be gradually applied to the straps either side of the fastener. Maintain this force for 1 min.

6.10.3.3 Effectiveness of the adjustment system

Use approximately 125 mm of the restraint system on either side of the adjustment system.

Fix one end of the test piece into one jaw of a dynamometer and the other end into another jaw. The distance between the jaws should be 200 mm.

Draw a line across the width of the test piece flush with each jaw.

Set the jaw movement speed to (500 ± 10) mm/min. Reduce the distance between the jaws to 150 mm. Subject the test piece to a tensile strain until the latter reaches (100 ± 10) N. When this strain has been reached, return the distance between the jaws to 150 mm.

Conduct the test for a total of 10 times.

Measure the distance between the lines drawn flush with the jaws. The difference between this dimension and original dimension of 200 mm is the amount of slippage.

7 Packaging

Any plastics used, as packaging shall have a minimum thickness of 0,038 mm thick unless the packaging comes into one or more of the following categories:

- a) bags with an opening perimeter of less than 380 mm;
- b) shrunk-on film packaging that is normally destroyed when the user opens the packaging;
- c) bags made of perforated film that make it possible for the child to breathe through the film and is unable to form a vacuum and stick to the face of the child. To comply with this any area of maximum dimensions 30 mm × 30 mm shall have a minimum hole area of 1 %.

8 Marking

8.1 General

Framed back carriers that conform to this standard shall be permanently marked with the following:

- a) the number and date of this document;
- b) the name or trademark or other means of identification of the manufacturer, importer or retailer;
- c) the maximum recommended weight of child for which the carrier is intended.

8.2 Labels on product

Any permanent labels shall be conspicuous and legible and labels shall be securely attached.

When tested in accordance with 8.3, it shall not be possible to remove any label or permanent marking, and labels shall show no signs of curling and the marking shall be legible.

8.3 Durability of marking

Any permanent marking or labels shall be rubbed by hand with a water damped cotton cloth for 20 s.

After the treatment the text shall still be clearly legible.

9 Instructions for use

Instructions concerning the correct safe use and assembly of the framed carrier shall be provided and shall be headed **“IMPORTANT! KEEP FOR FUTURE REFERENCE”** in letters not less than 5 mm high.

Instructions shall be provided in the official language(s) of the country in which it is being sold and shall include the following:

The instruction shall contain the following warnings

- a) WARNING - Do not leave the child unattended in this carrier!
- b) WARNING - Do not use until the child can sit unaided.
- c) WARNING - When the child is in the carrier, it could be in a position higher than the carer. Care should therefore be taken to be aware of hazards; e.g. door frames, low branches of trees etc.
- d) WARNING – When using the carrier the carer shall be aware of the following:
 - the carer's balance may be adversely affected due to movement of the child and also the carer;
 - the carer will need to take great care when bending or leaning forward;
 - the carrier is suitable for use when undertaking leisure activities but not for sports activities;
 - care should be taken when putting on or removing the carrier.

The instructions shall include at least the following

- e) the name registered trade name or trademark of the manufacturer, distributor or retailer;
- f) means of identifying the model;
- g) the recommended maximum weight of the child for which the carrier is intended;
- h) instructions and diagrams illustrating the correct means of assembly;
- i) instructions on how the carrier should be fitted correctly to the carer;
- j) instructions that the child's harness in the carrier should be securely fastened and adjusted in accordance with manufacturers instructions;

EN 13209-1:2004 (E)

- k) advise the carer that the child in the carrier can become tired and it is recommended to make frequent breaks;
- l) the following statement 'Be aware that the child in the carrier may suffer from the effect of the weather and temperature before you do';
- m) care should be taken to avoid injury to the child's feet when the carrier is on or near the floor;
- n) cleaning, washing and drying instructions;
- o) statement that additional or replacement parts should only be obtained from the manufacturer or distributor;
- p) instructions for the maintenance of the product;
- q) statement clearly indicating the intended function(s) of the carrier.

Annex A (informative)

It should be noted that for carriers for use where there are extremes of temperature, care should be taken to ensure that there are no exposed metallic parts in the carrier at the top or above the seat unit. These parts if exposed could become hot or cold and burn a child when seated in the carrier.

Copyrighted material

Bibliography

- [1] EN 1888, *Child care articles – Wheeled child conveyances – Safety requirements and test methods.*

BSI — British Standards Institution

BSI is the independent national body responsible for preparing British Standards. It presents the UK view on standards in Europe and at the international level. It is incorporated by Royal Charter.

Revisions

British Standards are updated by amendment or revision. Users of British Standards should make sure that they possess the latest amendments or editions.

It is the constant aim of BSI to improve the quality of our products and services. We would be grateful if anyone finding an inaccuracy or ambiguity while using this British Standard would inform the Secretary of the technical committee responsible, the identity of which can be found on the inside front cover.
Tel: +44 (0)20 8996 9000. Fax: +44 (0)20 8996 7400.

BSI offers members an individual updating service called PLUS which ensures that subscribers automatically receive the latest editions of standards.

Buying standards

Orders for all BSI, international and foreign standards publications should be addressed to Customer Services. Tel: +44 (0)20 8996 9001.
Fax: +44 (0)20 8996 7001. Email: orders@bsi-global.com. Standards are also available from the BSI website at <http://www.bsi-global.com>.

In response to orders for international standards, it is BSI policy to supply the BSI implementation of those that have been published as British Standards, unless otherwise requested.

Information on standards

BSI provides a wide range of information on national, European and international standards through its Library and its Technical Help to Exporters Service. Various BSI electronic information services are also available which give details on all its products and services. Contact the Information Centre.
Tel: +44 (0)20 8996 7111. Fax: +44 (0)20 8996 7048. Email: info@bsi-global.com.

Subscribing members of BSI are kept up to date with standards developments and receive substantial discounts on the purchase price of standards. For details of these and other benefits contact Membership Administration.
Tel: +44 (0)20 8996 7002. Fax: +44 (0)20 8996 7001.
Email: membership@bsi-global.com.

Information regarding online access to British Standards via British Standards Online can be found at <http://www.bsi-global.com/bsonline>.

Further information about BSI is available on the BSI website at <http://www.bsi-global.com>.

Copyright

Copyright subsists in all BSI publications. BSI also holds the copyright, in the UK, of the publications of the international standardization bodies. Except as permitted under the Copyright, Designs and Patents Act 1988 no extract may be reproduced, stored in a retrieval system or transmitted in any form or by any means – electronic, photocopying, recording or otherwise – without prior written permission from BSI.

This does not preclude the free use, in the course of implementing the standard, of necessary details such as symbols, and size, type or grade designations. If these details are to be used for any other purpose than implementation then the prior written permission of BSI must be obtained.

Details and advice can be obtained from the Copyright & Licensing Manager.
Tel: +44 (0)20 8996 7070. Fax: +44 (0)20 8996 7553.
Email: copyright@bsi-global.com.