

# Shutters and blinds — Additional thermal resistance — Allocation of a class of air permeability to a product

The European Standard EN 13125:2001 has the status of a  
British Standard

ICS 91.060.50

## National foreword

This British Standard is the official English language version of EN 13125:2001.

The UK participation in its preparation was entrusted by Technical Committee B/538, Doors, windows, shutters, hardware and curtain walling, to Subcommittee B/538/3, Domestic shutters and blinds, which has the responsibility to:

- aid enquirers to understand the text;
- present to the responsible European committee any enquiries on the interpretation, or proposals for change, and keep the UK interests informed;
- monitor related international and European developments and promulgate them in the UK.

A list of organizations represented on this subcommittee can be obtained on request to its secretary.

### Cross-references

The British Standards which implement international or European publications referred to in this document may be found in the BSI Standards Catalogue under the section entitled “International Standards Correspondence Index”, or by using the “Find” facility of the BSI Standards Electronic Catalogue.

A British Standard does not purport to include all the necessary provisions of a contract. Users of British Standards are responsible for their correct application.

**Compliance with a British Standard does not of itself confer immunity from legal obligations.**

This British Standard, having been prepared under the direction of the Sector Committee for Building and Civil Engineering, was published under the authority of the Standards Committee and comes into effect on 15 June 2001

### Summary of pages

This document comprises a front cover, an inside front cover, the EN title page, pages 2 to 15 and a back cover.

The BSI copyright date displayed in this document indicates when the document was last issued.

### Amendments issued since publication

Amd. No.	Date	Comments

© BSI 06-2001

ISBN 0 580 37154 9

---

ICS 91.060.50; 91.120.10

English version

## Shutters and blinds - Additional thermal resistance - Allocation of a class of air permeability to a product

Fermetures pour baies équipées de fenêtres, stores intérieurs et extérieurs - Résistance thermique additionnelle - Attribution d'une classe de perméabilité à l'air à un produit

Abschlüsse - Zusätzlicher Wärmedurchlasswiderstand - Zuordnung einer Luftdurchlässigkeitsklasse zu einem Produkt

This European Standard was approved by CEN on 8 March 2001.

CEN members are bound to comply with the CEN/CENELEC Internal Regulations which stipulate the conditions for giving this European Standard the status of a national standard without any alteration. Up-to-date lists and bibliographical references concerning such national standards may be obtained on application to the Management Centre or to any CEN member.

This European Standard exists in three official versions (English, French, German). A version in any other language made by translation under the responsibility of a CEN member into its own language and notified to the Management Centre has the same status as the official versions.

CEN members are the national standards bodies of Austria, Belgium, Czech Republic, Denmark, Finland, France, Germany, Greece, Iceland, Ireland, Italy, Luxembourg, Netherlands, Norway, Portugal, Spain, Sweden, Switzerland and United Kingdom.



EUROPEAN COMMITTEE FOR STANDARDIZATION  
COMITÉ EUROPÉEN DE NORMALISATION  
EUROPÄISCHES KOMITEE FÜR NORMUNG

Management Centre: rue de Stassart, 36 B-1050 Brussels

## CONTENTS

	Page
<b>Foreword</b> .....	<b>3</b>
<b>1 Scope</b> .....	<b>3</b>
<b>2 Normative references</b> .....	<b>3</b>
<b>3 Terms and definitions</b> .....	<b>4</b>
<b>4 Shutters - Allocation of air permeability classes</b> .....	<b>4</b>
4.1 Criteria for classes allocation .....	4
4.2 Minimum classes admitted without assessment .....	7
4.3 Conditions of allocation of class 5 .....	7
<b>5 External blinds, internal blinds, blinds incorporated into the glazing - Allocation of air permeability classes</b> .....	<b>9</b>
5.1 Criteria for class allocation .....	9
5.2 External blinds .....	9
5.3 Internal blinds and blinds incorporated into the glazing .....	10
5.4 Blinds with one side with low emissivity coating .....	11
<b>6 Presence of a top box (case of roller shutter)</b> .....	<b>11</b>
6.1 Top box independent of window frame (roller shutter for subsequent installation for instance) .....	11
6.2 Top box installed inside the masonry (see Figure 3a) or with the framing (see Figure 3b) .....	11
<b>ANNEX A (normative) Thermal resistance of PVC profiles curtain</b> .....	<b>13</b>
<b>ANNEX B (informative) Usual values of peripheral gaps for interior blinds and blinds incorporated into the glazing</b> .....	<b>14</b>

## Foreword

This European Standard has been prepared by Technical Committee CEN/TC 33 "Doors, Windows, Shutters, Building Hardware and Curtain Walling" the secretariat of which is held by AFNOR.

This European Standard shall be given the status of a national standard, either by publication of an identical text or by endorsement, at the latest by October 2001, and conflicting national standards shall be withdrawn at the latest by October 2001.

It is a part of a series of standards dealing with blinds and shutters for buildings as defined in prEN 12216:1995.

Annex A is normative and annex B is informative.

According to the CEN/CENELEC Internal Regulations, the national standards organizations of the following countries are bound to implement this European Standard: Austria, Belgium, Czech Republic, Denmark, Finland, France, Germany, Greece, Iceland, Ireland, Italy, Luxembourg, Netherlands, Norway, Portugal, Spain, Sweden, Switzerland and the United Kingdom.

## 1 Scope

This European Standard specifies the classification criteria of shutters and internal and external blinds in relation with their air permeability for the calculation of additional thermal resistance given by these products according to EN ISO 10077-1.

This standard applies to shutters and blinds fitted to a window, a French window or a curtain walling in such a way that in extended and closed position they inclose an air layer of thickness roughly constant between 15 mm and 300 mm (shutters and blinds parallel to the window or to the façade).

This standard applies to the following shutters and blinds :

- **Shutters** : roller shutter, external venetian blind, wing shutter, sliding panel shutter, venetian shutter, concertina shutter, flat-closing concertina shutter ;
- **External blinds** : vertical awning, facade awning, conservatory awning ;
- **Internal blinds** : venetian blind, roller blind, vertical blind, pleated blind ;
- Blinds incorporated into glazing.

## 2 Normative references

This European Standard incorporates by dated or undated reference, provisions from other publications. These normative references are cited at the appropriate places in the text and the publications are listed hereafter. For dated references, subsequent amendments to, or revisions of, any of these publications apply to this European Standard only when incorporated in it by amendment or revision. For undated references, the latest edition of the publication referred to applies (including amendments).

- EN 673 Glass in building - Determination of thermal transmittance ( $U$  value) - Calculation method
- EN ISO 6946 Building components and building elements - Thermal resistance and thermal transmittance - Calculation method
- ISO 8302 Thermal insulation - Determination of steady-state thermal resistance and related properties - Guarded hot plate apparatus
- EN ISO 10077-1 Thermal performance of windows, doors and shutters - Calculation of thermal transmittance - Part 1 : Simplified method (ISO 10077-1:2000)
- prEN ISO 10077-2:1998 Thermal performance of windows, doors and shutters - Calculation of thermal transmittance - Part 2 : Numerical method for frames (ISO/DIS 10077-2:1998)
- EN ISO 10211-1 Thermal bridges in building construction - Heat flow and surface temperatures - Part 1: General calculation methods (ISO 10211-1:1995)
- prEN 12216:1995 Terminology and definitions for blinds and shutters
- EN 12835 Air tight shutters - Air permeability test

### 3 Terms and definitions

For the purposes of this European Standard, the terms and definitions given in prEN 12216:1995 and EN ISO 10077-1 apply.

## 4 Shutters - Allocation of air permeability classes

### 4.1 Criteria for classes allocation

The air permeability criterion is expressed from geometrical considerations in terms of a total gap between shutter and its surrounding. The total gap is expressed as follows :

$$e_{\text{tot}} = e_1 + e_2 + e_3 \quad [\text{mm}]$$

where :

$e_{\text{tot}}$  is the total gap

$e_1$ ,  $e_2$ ,  $e_3$ , are the average gap at the bottom, top and side of the shutter. These values are defined on Figure 1.

The gap conditions to be fulfilled will be specified by the shutter manufacturer in his installation instructions.

When the dimensions of the gap widths are not well defined, the air permeability is determined by test, according to EN 12835.

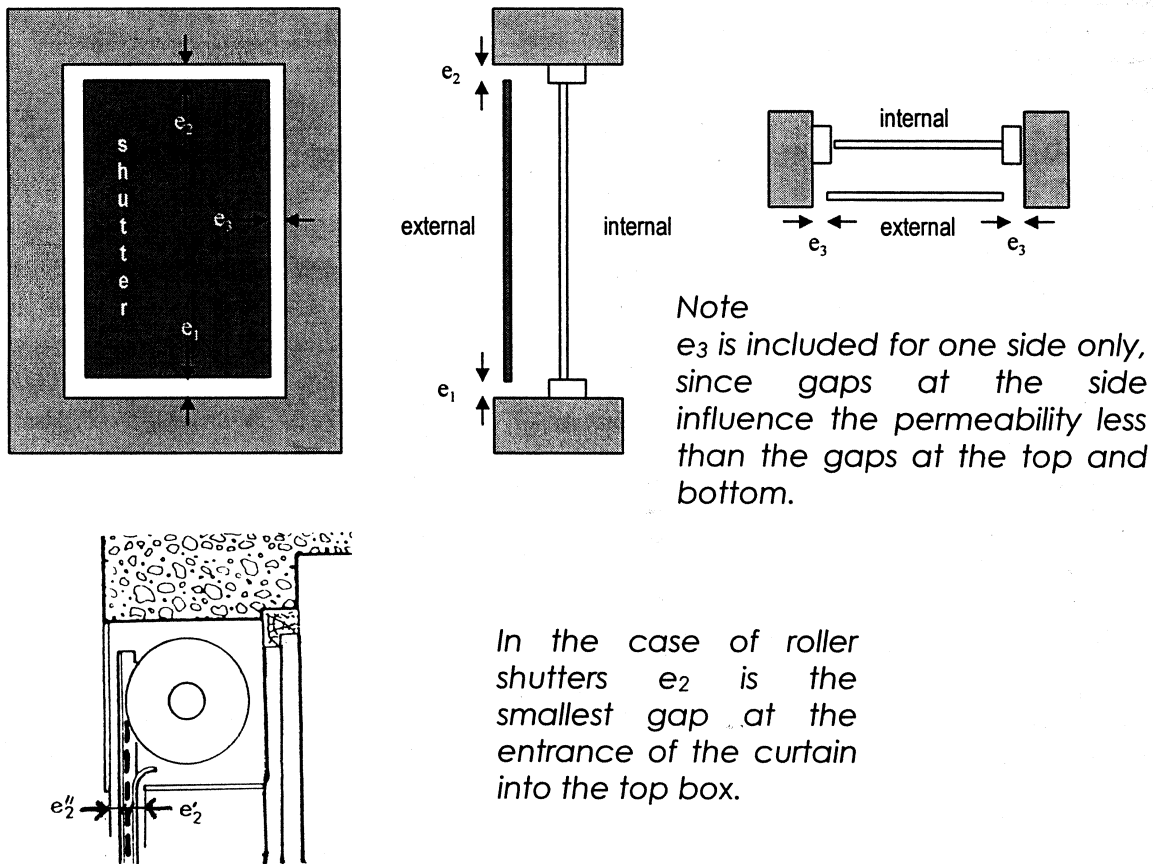

**Figure 1 - Definition of edge gap widths**

**Class 1 :** Shutters with very high air permeability

$$\Delta R = 0,08 \quad [\text{m}^2 \cdot \text{K}/\text{W}]$$

Shutters for which the total surface of slits (peripheral gaps, openings or slits within the curtain) is not greater than 25 % of the total curtain surface.

$$e_{\text{tot}} > 35 \text{ mm}$$

**Class 2 :** Shutters with high air permeability

$$\Delta R = 0,25R_{\text{sh}} + 0,09 \quad [\text{m}^2 \cdot \text{K}/\text{W}]$$

Shutters for which

- the curtain has no openings or slits  
and

$$- 15 \text{ mm} < e_{\text{tot}} \leq 35 \text{ mm}$$

**Class 3 :** Shutters with average air permeability

$$\Delta R = 0,55 R_{sh} + 0,11 \quad [m^2.K/W]$$

Shutters for which

- the curtain is without slits and with overlapped laths or slats  
*and*

-  $8 \text{ mm} < e_{tot} \leq 15 \text{ mm}$

**Class 4 :** Shutters with low air permeability

$$\Delta R = 0,8 R_{sh} + 0,14 \quad [m^2.K/W]$$

Shutters for which

- the curtain is without slits and with overlapped laths or slats  
*and*

-  $e_{tot} \leq 8 \text{ mm}$

**Class 5 :** "Air tight" shutters

$$\Delta R = 0,95 R_{sh} + 0,17 \quad [m^2.K/W]$$

Shutters for which

- the curtain is without slits and with overlapped laths or slats  
*and*

-  $e_{tot} \leq 3 \text{ mm}$

*and*

-  $e_1 + e_3 = 0$  or  $e_2 + e_3 = 0$

$R_{sh}$  is the thermal resistance of the shutter curtain.

The above equations are valid for :

$$R_{sh} < 0,3 \quad [m^2.K/W]$$

The thermal resistance value of the curtain  $R_{sh}$  is obtained :

- either by tests according to ISO 8302

- or by calculation according EN ISO 6946 for curtain with homogeneous materials or EN ISO 10211-1 for curtain with heterogeneous materials or profiles or according to prEN ISO 10077-2:1998 for profiles.

In the absence of measured or calculated values of  $R_{sh}$ , the thermal resistance of the PVC profiles in the curtain may be evaluated according to annex A.

The  $R_{sh}$  and  $\Delta R$  values are given to two decimal places according to the following rule :

-  $\geq 0,005 = 0,01$

-  $< 0,005 = 0,00$



The  $R_{sh}$  value is not affected by a top box (see clause 6).

#### 4.2 Minimum classes admitted without assessment

Table 1 gives minimum classes obtained by some types of shutters without having been proven  $e_{tot}$ , with the other conditions given in 4.1 having been fulfilled.

**Table 1 - Minimum air permeability classes of shutters**

Products	Minimal classes
Concertina shutter - Shutter with tilting slats or laths - Foldable shutter (wing or venetian shutter) with fixed openings	1
Shutter without openings or slits in extended position - External venetian blind with rigid joined laths in closed position	2
Flat-closing concertina shutter without openings or slots in extended position. Solid wing shutter closely adjusted	3
Roller shutter with strip gaskets (without slits in closed position)	4

#### 4.3 Conditions of allocation of class 5

The criteria relating to class 5 are as follows :

##### a) roller shutter :

- $e_3$  is considered equal to 0 if strip gaskets are supplied in guide rails (brush or lip sealing), whatever the laths curvature ;
- $e_1$  is considered equal to 0 in presence of a strip gasket at bottom of the final lath ;
- $e_2$  is considered equal to 0 if any of the joint settings shown in Figures 2a and 2b are realised at the entrance of the roller shutter box.

Its installation needs additionally :

- realisation of air tightness of connection between the guide rails and the windows closure ;
- realisation of air tightness between the roller box and the masonry or framing (see Figures 3c and 3d) ;
- continuous contact with window-sill of the strip gasket at the bottom of the final lath.

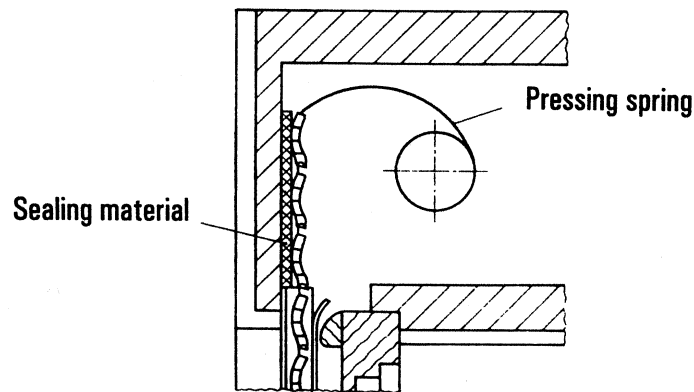

**Key**

- 1 Pressing spring
- 2 Sealing material

**2a - In the fully extended position of the curtain, a device (for example a spring) allows the curtain to be held permanently against the side of the roller box, with interposition of a sealing material.**

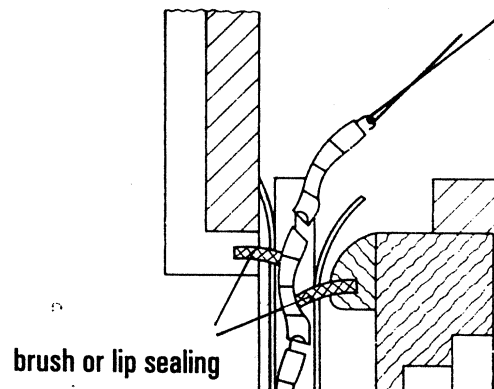

**Key**

- 1 Brush or lip sealing

**2b - the box entrance is fitted with "lips" or "brush" -type joints laying on the two sides of the curtain.**

**Figure 2 - Examples of realisation of  $e_2 = 0$  condition for roller shutters**

**b) other shutters :**

Presence of strip gaskets on three sides, the fourth side fulfilling the condition  $e_1$  or  $e_2 \leq 3$  mm

### c) proof by measurement of air permeability

Air permeability  $Q_{m/s}$  measured according to EN 12835, shall fulfill the following condition :

$$Q_{m/s} \leq 10 \quad [m^3/h.m^2]$$

$Q_{m/s}$  being the air flow rate through the shutter reduced to  $m^2$  of the overall surface area  $S$  of the shutter under a pressure drop of 10 Pa between both sides.

These shutters shall be delivered with the airtightness devices allowing the above airflow conditions to be fulfilled.

## 5 External blinds, internal blinds, blinds incorporated into the glazing - Allocation of air permeability classes

### 5.1 Criteria for class allocation

The given classification depends on air permeability of the blinds, which is a function of :

- the width of peripheral gaps ;
- the air permeability of the curtain itself in extended and closed position.

Air permeability criterion is expressed by the relationship :

$$P_e = e_{tot} + 10p \quad [mm]$$

where :

$e_{tot}$  is the sum, in mm, of peripheral gaps  $e_1$ ,  $e_2$ ,  $e_3$  as defined in 4.1 ;

$p$ , expressed in percent, represents the ratio between the voids area and the total area of the curtain.

For fabrics,  $p$  is the "openness factor" of the fabric<sup>1)</sup>

For venetian blinds,  $p$  is the ratio between the sum of surface areas of residual gaps between closed lathes, and the total surface area of the curtain. Without assessment, a lump value  $p = 4 \%$  is to be considered for these products.

### 5.2 External blinds

**Class 1:** Blinds with high and very high air permeability

$$\Delta R = 0,08 \quad [m^2.K/W]$$

Blinds for which

$$P_e \geq 35 \text{ mm}$$

---

<sup>1)</sup> It is obtained according to the standard in preparation (WI00033095 "Blinds and shutters - Thermal and visual comfort - Test methods").

**Class 2 :** Blinds with average air permeability

$$\Delta R = 0,11 \quad [\text{m}^2.\text{K}/\text{W}]$$

Blinds for which

$$8 \text{ mm} \leq P_e < 35 \text{ mm}$$

**Class 3 :** Blinds with low air permeability

$$\Delta R = 0,14 \quad [\text{m}^2.\text{K}/\text{W}]$$

Blinds for which

$$P_e < 8 \text{ mm}$$

### 5.3 Internal blinds and blinds incorporated into the glazing

**Class 1 :** Blinds with high or very high air permeability

$$\Delta R = 0,08 \quad [\text{m}^2.\text{K}/\text{W}]$$

Blinds for which

$$P_e \geq 80 \text{ mm}$$

**Class 2 :** Blinds with average air permeability

$$\Delta R = 0,11 \quad [\text{m}^2.\text{K}/\text{W}]$$

Blinds for which

$$20 \text{ mm} \leq P_e < 80 \text{ mm}$$

**Class 3 :** Blinds with low air permeability

$$\Delta R = 0,14 \quad [\text{m}^2.\text{K}/\text{W}]$$

Blinds for which

$$P_e < 20 \text{ mm}$$

Vertical blinds, are class 1 whatever the value of  $p$ .

The values of  $\Delta R$  obtained with incorporated blinds apply if the blind curtain in closed position has two free spaces of minimum 12 mm thickness between blind and panes.

NOTE If this is not the case, the blind performances may be significantly reduced, especially in the case of metallic venetian blinds.

Annex B gives the usual values of peripheral gaps  $e_1$ ,  $e_2$ ,  $e_3$  according to the method of fix and the attention given to the fix.

#### 5.4 Blinds with one side with low emissivity coating

Additional thermal resistances  $\Delta R$  given in 5.3 shall be multiplied by a factor  $k$  with the following values :

- Internal blinds, with the low emissivity coating blind side in front of the glazing.

$$k = [1 + 1,54 (1 - \varepsilon/0,9)^2]$$

- Blinds incorporated into the glazing, with one of the blind sides with a low emissivity coating.

$$k = 1 + 2 (1 - \varepsilon/0,9)^2$$

where  $\varepsilon$  is the emissivity of the blind side considered determined according to EN 673.

### 6 Presence of a top box (case of roller shutter)

#### 6.1 Top box independent of window frame (roller shutter for subsequent installation for instance)

The top box does not affect the  $R_{sh}$  value

- either because, it is installed outside the bay (see Figure 3d)
- or because, inside the bay, its own thermal resistance is considered higher than curtain thermal resistance (see Figure 3c)

#### 6.2 Top box installed inside the masonry (see Figure 3a) or with the framing (see Figure 3b)

The top box has no incidence on the  $R_{sh}$  value. It is a building component of the facade and calculated as such.

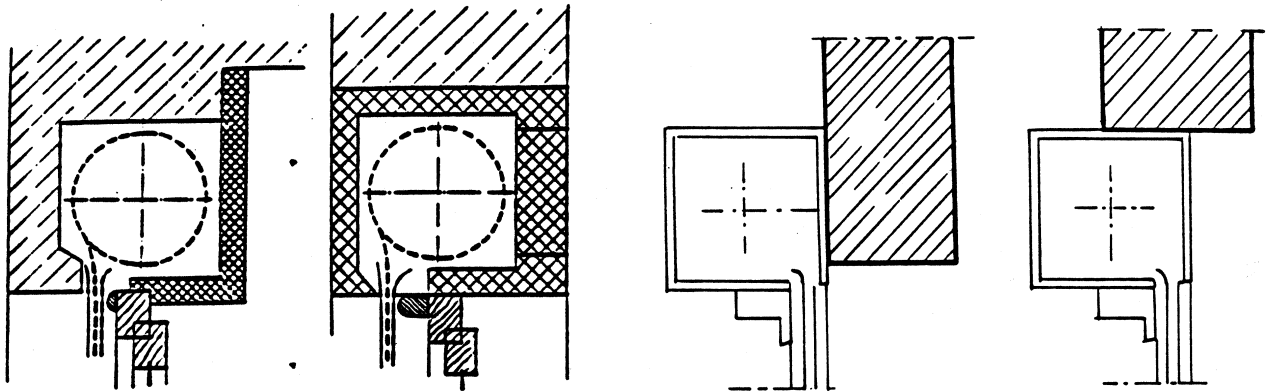

3a

3b

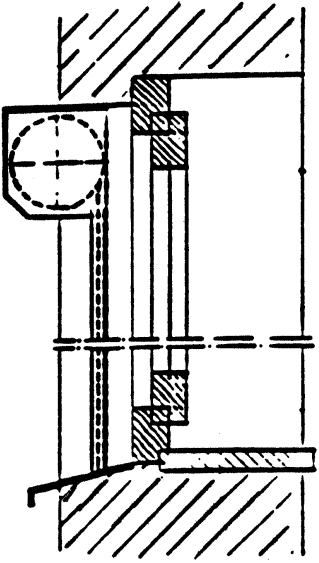

3c

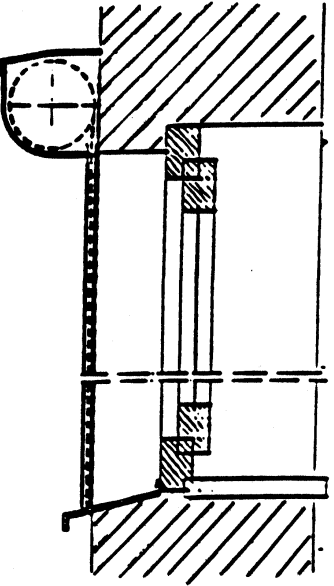

3d

Figure 3 - Top box - Face fixed

**ANNEX A**  
(normative)

**Thermal resistance of PVC profiles curtain**

If no measured or calculated values according to EN ISO 10077-2:1998 of  $R_{sh}$  are available, the following relationship may be used to evaluate the thermal resistance  $R_{sh}$  of curtains made of PVC profiles not infilled with foam.

$$R_{sh} = 0,0157 d - 0,00034 d^2 \quad [m^2.K/W]$$

where

$d$  is the mean actual thickness of profile in millimetres (mm).

This relationship is valid for  $d \leq 25$  mm.

The mean actual thickness of profile is defined as the mean value of profile thicknesses measured at the centre of each cavity, perpendicularly to the profile mean line.

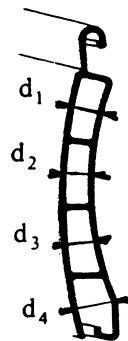

$$d = \frac{d_1 + d_2 + d_3 + d_4}{4}$$

**Figure A.1**

**ANNEX B**  
(informative)

**Usual values of peripheral gaps for interior blinds and blinds incorporated into the glazing**

The Tables B.1 and B.2 may be used to give the usual values of peripheral gaps in relation to the type of installation, in order to determine easily the class of thermal resistance of interior blinds and blinds incorporated in the glazing :

- $e_1$  : lower gap
- $e_2$  : upper gap
- $e_3$  : side gap

**Table B.1 - Interior blinds - Usual values of peripheral gaps**

PRODUCTS	POSITION	INSTALLATION	lower gap	upper gap	side gap
			$e_1$ [mm]	$e_2$ [mm]	$e_3$ [mm]
Pleated blind	Inside framing	careful	0	0	20
		adjusted	0	0	2
	Outside framing	careful	25	0	60
		adjusted	0	0	17
Venetian blind	Inside framing	careful	10	3	10
		adjusted	5	3	3
	Outside framing	careful	50	3	60
		adjusted	5	3	17
Roller blind without guides nor box	Inside framing	careful	50	40	40
		adjusted	10	20	20
	Outside framing	careful	55	40	55
		adjusted	20	20	20
Roller blinds with guides and box	Inside framing or	adjusted	20	10	15
		adjusted	10	2	2
	Outside framing	adjusted	0	2	2

NOTE Adjusted installation means that the dimensions of the blind need to be taken on site.



**Table B.2 - Blinds incorporated into the glazing - Usual values of peripheral gaps**

PRODUCTS	POSITION	INSTALLATION	lower gap	upper gap	side gap
			$e_1$ [mm]	$e_2$ [mm]	$e_3$ [mm]
Pleated blind	Incorporated	adjusted	0	0	2
Venetian blind	Incorporated	adjusted	3	5	2
Roller blind	Incorporated	adjusted	10	5	5

---

---

## BSI — British Standards Institution

BSI is the independent national body responsible for preparing British Standards. It presents the UK view on standards in Europe and at the international level. It is incorporated by Royal Charter.

### Revisions

British Standards are updated by amendment or revision. Users of British Standards should make sure that they possess the latest amendments or editions.

It is the constant aim of BSI to improve the quality of our products and services. We would be grateful if anyone finding an inaccuracy or ambiguity while using this British Standard would inform the Secretary of the technical committee responsible, the identity of which can be found on the inside front cover. Tel: 020 8996 9000. Fax: 020 8996 7400.

BSI offers members an individual updating service called PLUS which ensures that subscribers automatically receive the latest editions of standards.

### Buying standards

Orders for all BSI, international and foreign standards publications should be addressed to Customer Services. Tel: 020 8996 9001. Fax: 020 8996 7001. Standards are also available from the BSI website at <http://www.bsi-global.com>.

In response to orders for international standards, it is BSI policy to supply the BSI implementation of those that have been published as British Standards, unless otherwise requested.

### Information on standards

BSI provides a wide range of information on national, European and international standards through its Library and its Technical Help to Exporters Service. Various BSI electronic information services are also available which give details on all its products and services. Contact the Information Centre. Tel: 020 8996 7111. Fax: 020 8996 7048.

Subscribing members of BSI are kept up to date with standards developments and receive substantial discounts on the purchase price of standards. For details of these and other benefits contact Membership Administration. Tel: 020 8996 7002. Fax: 020 8996 7001. Further information about BSI is available on the BSI website at <http://www.bsi-global.com>.

### Copyright

Copyright subsists in all BSI publications. BSI also holds the copyright, in the UK, of the publications of the international standardization bodies. Except as permitted under the Copyright, Designs and Patents Act 1988 no extract may be reproduced, stored in a retrieval system or transmitted in any form or by any means – electronic, photocopying, recording or otherwise – without prior written permission from BSI.

This does not preclude the free use, in the course of implementing the standard, of necessary details such as symbols, and size, type or grade designations. If these details are to be used for any other purpose than implementation then the prior written permission of BSI must be obtained.

If permission is granted, the terms may include royalty payments or a licensing agreement. Details and advice can be obtained from the Copyright Manager. Tel: 020 8996 7070.