

Products used for treatment of water intended for human consumption — Inorganic supporting and filtering materials — Methods of test

The European Standard EN 12902:2004 has the status of a
British Standard

ICS 71.100.80

National foreword

This British Standard is the official English language version of EN 12902:2004. It supersedes BS EN 12902:1999, which is withdrawn.

The UK participation in its preparation was entrusted to Technical Committee CII/59, Chemicals for drinking water treatment, which has the responsibility to:

- aid enquirers to understand the text;
- present to the responsible international/European committee any enquiries on the interpretation, or proposals for change, and keep the UK interests informed;
- monitor related international and European developments and promulgate them in the UK.

A list of organizations represented on this committee can be obtained on request to its secretary.

Cross-references

The British Standards which implement international or European publications referred to in this document may be found in the *BSI Catalogue* under the section entitled “International Standards Correspondence Index”, or by using the “Search” facility of the *BSI Electronic Catalogue* or of British Standards Online.

This publication does not purport to include all the necessary provisions of a contract. Users are responsible for its correct application.

Compliance with a British Standard does not of itself confer immunity from legal obligations.

Summary of pages

This document comprises a front cover, an inside front cover, the EN title page, pages 2 to 36, an inside back cover and a back cover.

The BSI copyright notice displayed in this document indicates when the document was last issued.

Amendments issued since publication

| Amd. No. | Date | Comments |
|----------|------|----------|
| | | |
| | | |
| | | |
| | | |
| | | |

This British Standard was published under the authority of the Standards Policy and Strategy Committee on 2 December 2004

© BSI 2 December 2004

ISBN 0 580 44953 X

EUROPEAN STANDARD

EN 12902

NORME EUROPÉENNE

EUROPÄISCHE NORM

November 2004

ICS 71.100.80

Supersedes EN 12902:1999

English version

Products used for treatment of water intended for human consumption - Inorganic supporting and filtering materials - Methods of test

Produits chimiques utilisés pour le traitement de l'eau destinée à la consommation humaine - Matériaux inorganiques de filtration et de support - Méthodes d'essai

Produkte zur Aufbereitung von Wasser für den menschlichen Gebrauch - Anorganische Filterhilfs- und Filtermaterialien - Prüfverfahren

This European Standard was approved by CEN on 30 September 2004.

CEN members are bound to comply with the CEN/CENELEC Internal Regulations which stipulate the conditions for giving this European Standard the status of a national standard without any alteration. Up-to-date lists and bibliographical references concerning such national standards may be obtained on application to the Central Secretariat or to any CEN member.

This European Standard exists in three official versions (English, French, German). A version in any other language made by translation under the responsibility of a CEN member into its own language and notified to the Central Secretariat has the same status as the official versions.

CEN members are the national standards bodies of Austria, Belgium, Cyprus, Czech Republic, Denmark, Estonia, Finland, France, Germany, Greece, Hungary, Iceland, Ireland, Italy, Latvia, Lithuania, Luxembourg, Malta, Netherlands, Norway, Poland, Portugal, Slovakia, Slovenia, Spain, Sweden, Switzerland and United Kingdom.



EUROPEAN COMMITTEE FOR STANDARDIZATION
COMITÉ EUROPÉEN DE NORMALISATION
EUROPÄISCHES KOMITEE FÜR NORMUNG

Management Centre: rue de Stassart, 36 B-1050 Brussels

Contents

| | Page |
|---|------|
| Foreword..... | 3 |
| 1 Scope | 4 |
| 2 Normative references | 4 |
| 3 Terms and definitions | 4 |
| 4 Sampling | 4 |
| 5 Physical properties | 5 |
| 6 Chemical properties | 16 |
| Annex A (informative) Measurement of resistance to friability | 33 |

Foreword

This document (EN 12902:2004) has been prepared by Technical Committee CEN/TC 164 "Water supply", the secretariat of which is held by AFNOR.

This European Standard shall be given the status of a national standard, either by publication of an identical text or by endorsement, at the latest by May 2005, and conflicting national standards shall be withdrawn at the latest by May 2005.

This document supersedes EN 12902:1999.

Significant technical differences between this edition and EN 12902:1999 are as follows:

- a) Addition in 5.2.6 of a requirement to round results to the nearest 10 kg/m³.
- b) Modification of Table 4 to specify analytical performance characteristics instead of specific methods.
- c) Modification of 6.5 to allow the use of a larger test sample.
- d) Deletion of clause 7 (Determination of polynuclear aromatic hydrocarbons (PAH) in aqueous extracts).
- e) Correction of figure A.2.

According to the CEN/CENELEC Internal Regulations, the national standards organizations of the following countries are bound to implement this European Standard: Austria, Belgium, Cyprus, Czech Republic, Denmark, Estonia, Finland, France, Germany, Greece, Hungary, Iceland, Ireland, Italy, Latvia, Lithuania, Luxembourg, Malta, Netherlands, Norway, Poland, Portugal, Slovakia, Slovenia, Spain, Sweden, Switzerland and United Kingdom.

1 Scope

This document specifies methods of test to determine physical and chemical properties of Inorganic Supporting and Filtering Materials (ISFM).

NOTE The applicability of the methods is specified in the relevant product standard.

2 Normative references

The following referenced documents are indispensable for the application of this document. For dated references, only the edition cited applies. For undated references, the latest edition of the referenced document (including any amendments) applies.

EN 12901:1999, *Products used for treatment of water intended for human consumption – Inorganic supporting and filtering materials – Definitions.*

EN ISO 3696, *Water for analytical laboratory use – Specification and test methods (ISO 3696:1987).*

ISO 562, *Hard coal and coke – Determination of volatile matter.*

ISO 565, *Test sieves – Metal wire cloth, perforated metal plate and electroformed sheet – Nominal sizes of openings.*

ISO 609, *Solid mineral fuels – Determination of carbon and hydrogen – High temperature combustion method.*

ISO 2395, *Test sieves and test sieving – Vocabulary.*

ISO 2591-1, *Test sieving – Part 1: Methods using test sieves of woven wire cloth and perforated metal plate.*

ISO 3165, *Sampling of chemical products for industrial use – Safety in sampling.*

ISO 6206, *Chemical products for industrial use – Sampling – Vocabulary.*

ISO 8213, *Chemical products for industrial use – Sampling techniques – Solid chemical products in the form of particles varying from powders to coarse lumps.*

ISO 9276-1, *Representation of results of particle size analysis – Part 1: Graphical representation.*

ISO 13320-1, *Particle size analysis – Laser diffraction methods – Part 1: General principles.*

3 Terms and definitions

For the purpose of this document, the terms and definitions given in EN 12901:1999 apply.

4 Sampling

Observe the recommendations of ISO 3165 and see ISO 6206. Sample in accordance with ISO 8213 and obtain the laboratory sample from the bulk sample by using a divider.

5 Physical properties

5.1 Particle size distribution

5.1.1 General

The particle size distribution of granular materials shall be determined by sieving; this is applicable to distributions measured using sieves of nominal aperture size of 0,025 mm and above (see ISO 2591-1).

For powders, the particle size shall be determined according to the laser optical method (see 5.1.4).

NOTE Alternative methods for particle size determination include:

- water sieving for powders;
- size measurement with magnification: microscopic counting;
- particle fall in a fluid without acceleration: settling;
- particle fall in a fluid with acceleration: cycloning;
- electromagnetic wave diffraction: turbidity;
- dielectric properties: Coulter counter.

5.1.2 Principle

Measurement of particle size distribution by sieving for granular materials or laser diffraction for powders.

5.1.3 Particle size distribution for granular material

The particle size distribution for granular material shall be determined in accordance with ISO 2591-1; see also ISO 2395 and ISO 565.

5.1.4 Particle size distribution for powders

5.1.4.1 General

The laser diffraction method described applies to powders in suspension in a liquid or gaseous fluid as well as to aerosols or emulsions. Measurable particle sizes are between $0,5 \mu\text{m}$ and an upper limit linked to the optical configuration of the laser equipment used which can range up to $3\,600 \mu\text{m}$. The principle of the method and guidance on measurement are given in ISO 13320-1.

5.1.4.2 Reagents

All reagents shall be of a recognized analytical grade and the water used shall conform to grade 3 in accordance with EN ISO 3696.

5.1.4.3 Apparatus

Ordinary laboratory apparatus together with the following.

5.1.4.3.1 Laser diffraction instrument (see ISO 13320-1).

5.1.4.4 Measurement

Disperse the sample in a suitable fluid (e.g. water, see ISO 13320-1) and introduce it into the analyzer in accordance with the manufacturer's recommendations. Adjust the measurement conditions by carrying out repetitive analyses to optimize reproducibility. Measure the scattering pattern and convert the results to particle size distribution following the recommendations in ISO 13320-1.

5.1.5 Expression of results

The results shall be presented as a cumulative particle size distribution curve in accordance with ISO 9276-1.

5.1.6 Processing of results

From the cumulative particle size distribution curve, determine the value of the following parameters:

- effective size d_{10} ;
- uniformity coefficient U ;
- minimum size d_1 ;
- oversize percentage;
- undersize percentage.

5.2 Bulk density (loose and packed)

5.2.1 General

This method of measurement is not routinely used for materials with particle size greater than 4 mm.

5.2.2 Principle

The volume of dried ISFM, loose or packed, is determined in a measuring cylinder; dividing the mass of dried ISFM by its volume gives the bulk density.

5.2.3 Apparatus

Ordinary laboratory apparatus and glassware together with the following.

- 5.2.3.1 Balance with a capacity of 500 g or 2 000 g depending on volume of sample (see Table 1), with an accuracy of ± 1 g.
- 5.2.3.2 Desiccator.
- 5.2.3.3 Oven capable of being controlled at (105 ± 2) °C.
- 5.2.3.4 Graduated measuring cylinder of (250 ± 2) ml or $(1\ 000 \pm 10)$ ml according to Table 1.

5.2.4 Preparation of the sample

Dry a sufficient quantity of ISFM at (105 ± 2) °C to constant mass. Return to ambient temperature in the desiccator.

NOTE Porous material should be dried at (150 ± 2) °C.

The volume of sample is determined according to the particle size of ISFM (Table 1).

Table 1 – Minimum ISFM sample volume according to particle size

| ISFM | Maximum particle size mm | Measuring cylinder volume ml | Minimum sample volume ml |
|-------------------|-----------------------------|---------------------------------|-----------------------------|
| Powder | < 0,4 | 250 ± 2 | 100 |
| Granular material | 0,4 to 4 | $1\ 000 \pm 10$ | 500 |

5.2.5 Procedure

5.2.5.1 Loose material

Weigh the empty measuring cylinder and note its mass m_0 to the nearest 1 g. With the measuring cylinder (5.2.3.4) positioned vertically, pour the sample of ISFM into the measuring cylinder. Measure the volume of the loose material V_1 to the nearest 10 ml. Weigh the measuring cylinder full and note its mass m_1 to the nearest 1 g.

5.2.5.2 Packed material

Weigh the empty measuring cylinder (5.2.3.4) and note its mass m_0 to the nearest 1 g. With the measuring cylinder positioned vertically, pour the minimum volume of ISFM according to Table 1 into the measuring cylinder. Tap the walls of the measuring cylinder with a glass rod covered with a rubber sleeve until the volume of ISFM remains constant. Measure the volume V_1 . Weigh the measuring cylinder full and note its mass m_1 to the nearest 1 g.

5.2.6 Expression of result

The bulk density (ρ) of the material expressed in kilograms per cubic metre is calculated from the following equation:

$$\rho = \frac{m_1 - m_0}{V_1} \times 1000 \quad (1)$$

where

m_0 is the mass of the measuring cylinder, in grams;

m_1 is the mass of the sample of ISFM and the measuring cylinder, in grams;

V_1 is the volume of the ISFM in the measuring cylinder, in millilitres.

Express the result to the nearest 10 kg/m³.

5.3 Permeability of powders

5.3.1 General

The method is applicable to ISFM with median diameter (d_{50}) between 5 μm and 200 μm .

5.3.2 Principle

Measurement of the time needed for a fixed volume of water to flow across a cake of ISFM of precise dimensions under specified conditions of temperature and pressure.

5.3.3 Reagent

The fluid used for the test shall be water conforming to grade 3 in accordance with EN ISO 3696.

5.3.4 Apparatus

Ordinary laboratory apparatus and glassware together with the following

5.3.4.1 Permeameter

Figure 1 gives an example of a permeameter.

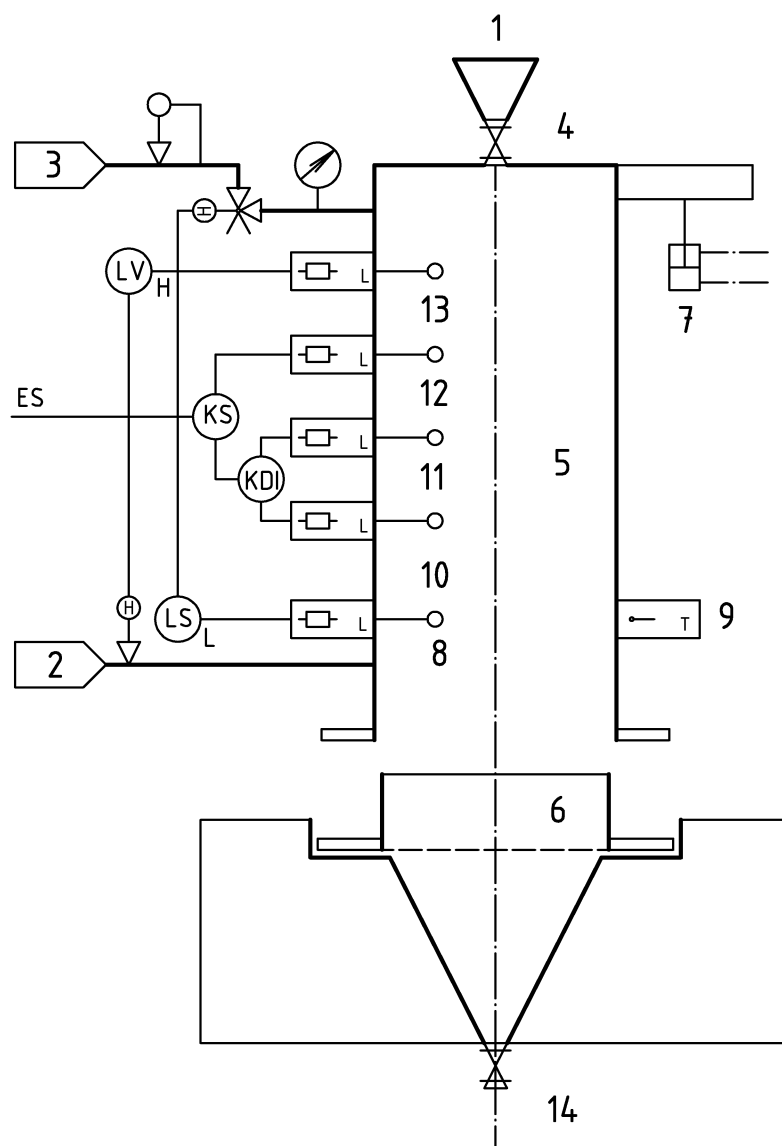

Key

- | | | | |
|---|--------------------------|-------|--------------------|
| 1 | funnel | 7 | pneumatic jack |
| 2 | test fluid | 8 | electric shut down |
| 3 | compressed air | 9 | thermometer |
| 4 | valve | 10-13 | electrodes |
| 5 | measurement chamber | 14 | drain valve |
| 6 | cylindrical cake carrier | | |

Figure 1 – Example of permeameter

- 5.3.4.2 Beaker 600 ml.
- 5.3.4.3 Flat ruler.
- 5.3.4.4 Fluid reservoir.
- 5.3.4.5 Reducing valve with a manometer 0 kPa to 220 kPa, readable to ± 2 kPa.
- 5.3.4.6 Thermometer 15 °C to 30 °C readable to $\pm 0,1$ °C.
- 5.3.4.7 Compressed air under 500 kPa.
- 5.3.4.8 Analytical balance capable of weighing up to 500 g with an accuracy of $\pm 0,01$ g.
- 5.3.4.9 Desiccator.
- 5.3.4.10 Oven capable of being controlled at (105 ± 2) °C.

5.3.5 Preparation of sample

Dry a sufficient quantity of ISFM at 105 °C in the beaker (5.3.4.2) to constant mass, return to ambient temperature in the desiccator (5.3.4.9). The mass of test sample (m) required depends on the dimensions of the filter cake holder (see 5.3.6) and is given by the following equation:

$$m = S \times h \times \rho_G \times 1,1 \tag{2}$$

where

- ρ_G is the cake density of the ISFM, in kilograms per cubic metre;
- S is the surface of the cake, in square centimetres;
- h is the height of the cake, in centimetres;
- 1,1 is a factor to ensure that a sufficiently large test sample is taken.

5.3.6 Procedure

Select a filter cake holder suitable for the quality of the filter material to be tested on the basis of its assumed permeability, according to Table 2:

Table 2 – Characteristics for the selection of the filter cake

| Presumed permeability | | Height of cake holder cm | Percolated volume ml | Driving pressure kPa |
|-----------------------|------------------------|-----------------------------|-------------------------|-------------------------|
| Darcy | 10^{-13} m^2 | | | |
| 0,01 to 0,4 | 0,0987 to 3,95 | 2,2 | 30 | 200 |
| 0,4 to 0,9 | 3,95 to 8,88 | 3,6 | 30 | 200 |
| 0,9 to 15 | 8,88 to 157 | 3,6 | 140 | 50 |
| 15 to 20 | 157 to 197,5 | 5,0 | 140 | 50 |

Select the appropriate programme, depending on the tested material and in accordance with the manufacturer's recommendations. Weigh the quantity of ISFM defined in 5.3.5. Add the sample to be tested to (200 ± 10) ml of water and thoroughly mix the suspension.

Pour the suspension into the funnel of the measurement chamber, stirring all the time to avoid any settlement. Initiate the formation of the cake and, by hand, level the filter cake using the ruler (5.3.4.3).

NOTE The accuracy of the method depends on the care taken when levelling the cake.

Initiate the measurement of permeability and record the pressure (kPa), temperature (°C) and filtration time (s).

5.3.7 Expression of result

The permeability B_0 (in Darcy) is calculated from the following equation:

$$B_0 = \frac{\Delta V}{\Delta t} \times \frac{1}{S} \times \frac{\mu}{P} \times \frac{1}{h} \quad (3)$$

where

ΔV is the volume of filtrate flowed during the time Δt (in seconds), in millilitres;

μ is the dynamic viscosity at the temperature of test, in millipascal seconds (mPa.s);

S is the filtering surface of the cake, in square centimetres;

h is the cake thickness, in centimetres;

P is the pressure, in pascals.

NOTE The permeability is usually expressed in Darcy, but for following the SI System the unit for the permeability is the square metre and the values should be calculated in multiplying by $9,87 \times 10^{-13}$.

The Table 3 gives the dynamic viscosity (μ) of water as a function of the temperature of the test.

Table 3 – Dynamic viscosity (μ) of water as a function of the temperature of the test

| Temperature °C | Dynamic viscosity mPa.s |
|-------------------|----------------------------|
| 0 | 1,787 |
| 5 | 1,519 |
| 10 | 1,307 |
| 15 | 1,139 |
| 20 | 1,002 |
| 25 | 0,890 |
| 30 | 0,798 |
| 35 | 0,719 |
| 40 | 0,653 |
| 50 | 0,547 |

5.4 Cake density

5.4.1 General

The cake density is the ratio between the mass of ISFM which is filtered on a filter and the volume occupied by the cake. The method is applicable to ISFM with median diameter (d_{50}) between 5 μm and 200 μm .

5.4.2 Principle

Filtration of a known mass of ISFM in suspension and measurement of the volume of filter cake formed.

5.4.3 Reagent

The fluid used for the test shall be water conforming to grade 3 in accordance with EN ISO 3696.

5.4.4 Apparatus

Ordinary laboratory apparatus and glassware together with the following

5.4.4.1 Filtering cell as shown in Figures 2 and 3.

The filtering cell comprises:

- cylinder (A) with internal diameter of (40 ± 5) mm and a height of (170 ± 20) mm;
- clamp (B);
- base (C);
- supporting plate (D);
- stainless steel screen (E) with square mesh, opening (30 ± 10) μm .

Figure 2 shows separated drawings of pieces (A) to (D) and Figure 3 shows the assembled apparatus without fixings and accessories.

5.4.4.2 Vacuum generator capable of supplying a constant vacuum of 65 kPa.

5.4.4.3 Balance capable of weighing up to 500 g with an accuracy of $\pm 0,01$ g.

5.4.4.4 Desiccator.

5.4.4.5 Oven capable of being controlled at (105 ± 2) °C.

5.4.4.6 Ruler 250 mm long, graduated in 0,5 mm.

5.4.4.7 Beaker, 600 ml.

Dimensions in millimetres

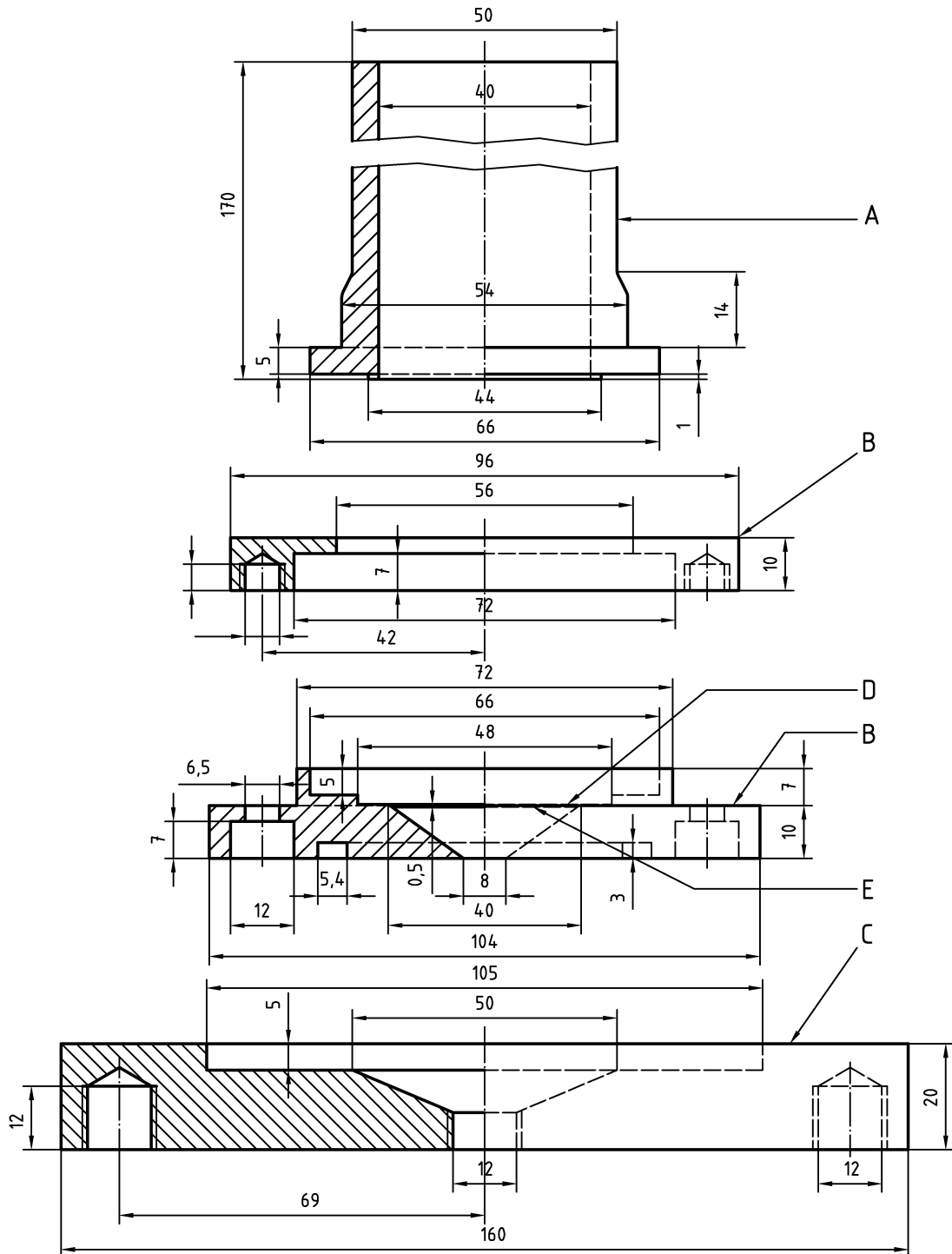
**Key**

- A cylinder with internal diameter of (40 ± 5) mm and a height of (170 ± 20) mm
- B clamp
- C base
- D supporting plate
- E stainless steel screen with square mesh, opening (30 ± 10) μm

Figure 2 – Example of filtering cell

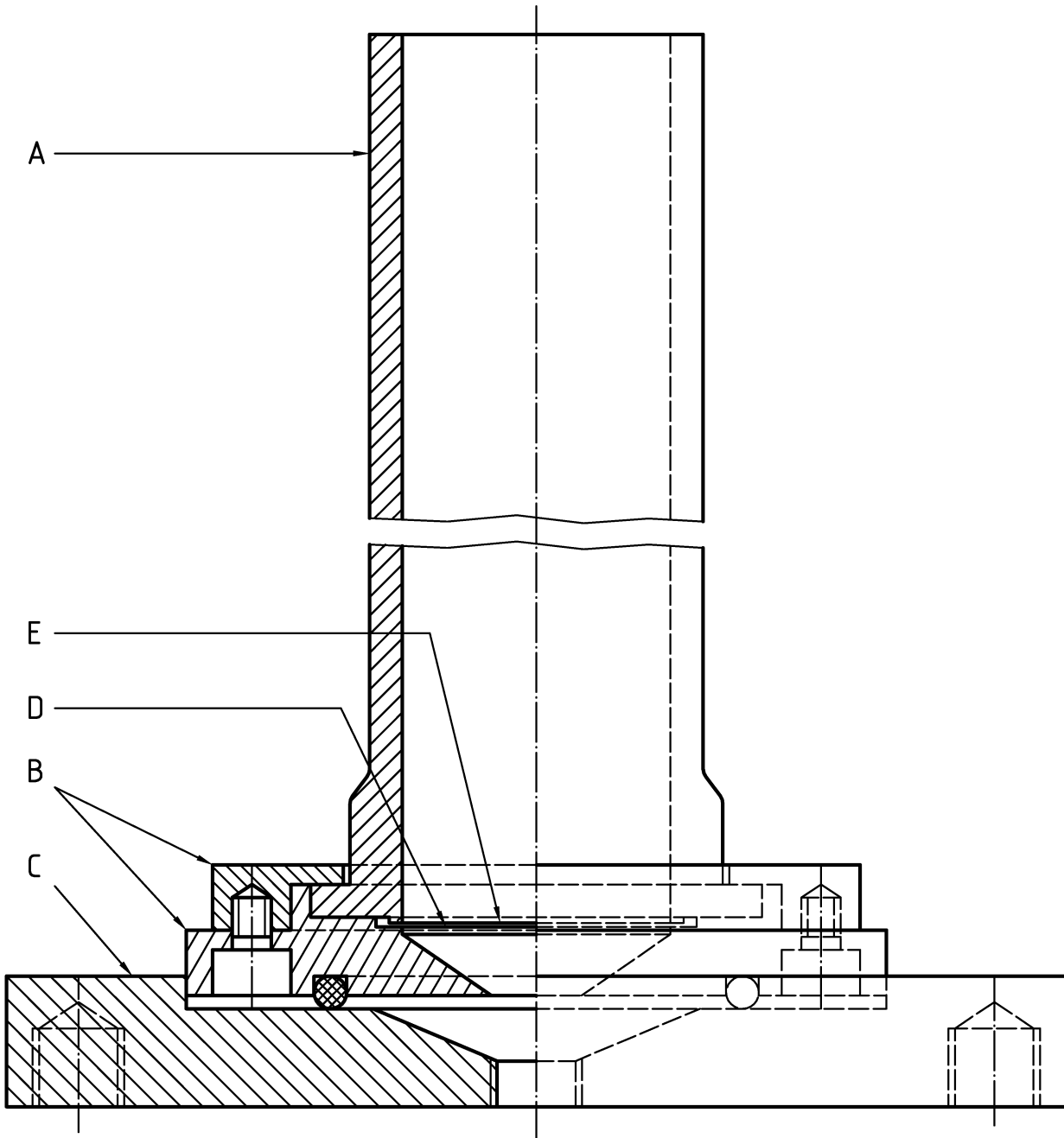

Key

- A cylinder with internal diameter of (40 ± 5) mm and a height of (170 ± 20) mm
- B clamp
- C base
- D supporting plate
- E stainless steel screen with square mesh, opening (30 ± 10) μm

Figure 3 – Example of assembly of the filtering cell

5.4.5 Preparation of sample

Dry a sufficient quantity of ISFM at 105 °C to constant mass, return to ambient temperature in the desiccator (5.4.4.4).

5.4.6 Procedure

Weigh, to nearest 0,01 g, approximately 20 g of ISFM in the beaker (5.4.4.7) and note its mass m_1 . Add (200 ± 10) ml of water and mix the suspension with a spatula. With the vacuum generator (5.4.4.2) connected to the cell, open the vacuum line and add the homogenized suspension into the filtering cell (5.4.4.1) in one operation. Quickly rinse the beaker with a minimum of water and add it to the filtering cell.

At the end of filtration, when the cake is dried (drop in vacuum), close the vacuum line. Measure with the ruler (5.4.4.6) the height between the cake surface and the top part of the funnel. Make four measurements and calculate the arithmetic mean h_1 in centimetres (to the nearest 0,1 cm).

5.4.7 Expression of results

The height of the cake, h , expressed in centimetres, is calculated from:

$$h = H - h_1 \quad (4)$$

where

H is the effective height of the interior cylinder of the filtering cell, in centimetres (between the level of the support mesh and the upper edge of the filtering cell);

h_1 is the height between the cake surface and the top of the funnel in centimetres.

The cake volume V , expressed in cubic centimetres, is calculated from:

$$V = S \times h \quad (5)$$

where

S is the area of the cross section of filtering cell, in square centimetres.

The cake density ρ_G expressed in grams per cubic centimetre, is calculated from the following equation:

$$\rho_G = \frac{m_1}{V} \quad (6)$$

where

m_1 is the mass in grams of the test sample of ISFM

6 Chemical properties

6.1 Acid-soluble material (acid loss)

6.1.1 General

This method is applicable to ISFM which are not chemically reactive with acid.

6.1.2 Principle

Immersion of ISFM in acid and determination of mass loss.

6.1.3 Reagents

All reagents shall be of a recognized analytical grade and the water used shall conform to grade 3 in accordance with EN ISO 3696.

6.1.3.1 Hydrochloric acid solution mass fraction 20 %, i.e. approximately 220 g HCl per litre, density, ρ , approximately 1,15 g/ml.

6.1.4 Apparatus

6.1.4.1 Balance capable of weighing up to 500 g with an accuracy of $\pm 0,1$ g.

6.1.4.2 Oven capable of being controlled at (105 ± 2) °C.

6.1.4.3 Beaker, 250 ml or 600 ml according to the density of the material.

6.1.4.4 Desiccator

6.1.5 Preparation of the sample

Dry a sufficient quantity of ISFM at 105 °C to constant mass in the oven (6.1.4.2). Return to ambient temperature in the desiccator (6.1.4.4).

6.1.6 Procedure

Weigh to the nearest 0,1 g, approximately 50 g of the ISFM and transfer to a beaker (6.1.4.3). Note the mass m_1 . Cover the ISFM sample with hydrochloric acid (6.1.3.1). Leave in contact for 24 h at a temperature between 18 °C and 23 °C.

Undertake five washings with water avoiding the loss of fines, and dry in the oven (6.1.4.2) at 105 °C to constant mass, then allow to cool in the desiccator. Weigh the ISFM, note the mass m_2 .

6.1.7 Expression of results

The loss of mass to the acid (X_1), expressed as mass fraction, is calculated from the following equation:

$$X_1 = \frac{(m_1 - m_2)}{m_1} \times 100 \quad (7)$$

where

m_1 is the mass of the sample of ISFM before the test, in grams;

m_2 is the mass of the sample of ISFM after the test, in grams.

6.2 Ash

6.2.1 General

This method is applicable to carbonaceous ISFM, e.g. anthracite, powdered activated carbon, granular activated carbon, pyrolyzed coal material.

6.2.2 Principle

The ash is determined by ignition of the sample to constant mass.

6.2.3 Apparatus

Ordinary laboratory apparatus and glassware together with the following.

6.2.3.1 Drying oven capable of being controlled at (150 ± 5) °C.

6.2.3.2 Muffle furnace, with air circulation, capable of being controlled at (650 ± 25) °C.

6.2.3.3 High-temperature crucible.

6.2.3.4 Desiccator.

6.2.3.5 Analytical balance, having an accuracy of $\pm 0,1$ mg.

6.2.4 Procedure

Dry an adequate sample of ISFM to constant mass at 150 °C in the drying oven (6.2.3.1).

Ignite the crucible in the muffle furnace (6.2.3.2) at (650 ± 25) °C for 1 h. Place the crucible in the desiccator (6.2.3.4), cool to room temperature and weigh to the nearest 0,1 mg; note the mass m_0 .

Into the ignited crucible, weigh, to the nearest 0,1 mg, sufficient dried sample so that the estimated amount of ash will be 0,1 g; note the mass m_1 . Place the crucible in the muffle furnace at (650 ± 25) °C and leave until constant mass is reached.

NOTE Ashing will normally require between 3 h and 16 h depending on type and particle size of the sample and can be considered to be complete when constant mass is attained.

Place the crucible in the desiccator and allow to cool to room temperature. When cool, admit air slowly to avoid loss of ash from the crucible. Weigh to the nearest 0,1 mg; note the mass m_2 .

6.2.5 Expression of results

The ash content (X_2), expressed as mass fraction of dried material, is calculated from the following equation:

$$X_2 = \frac{(m_2 - m_0)}{(m_1 - m_0)} \times 100 \quad (8)$$

where:

m_0 is the mass of the empty crucible, in grams;

m_1 is the mass of the crucible plus dried sample, in grams;

m_2 is the mass of the crucible plus ashed sample, in grams.

6.2.6 Precision

6.2.6.1 Repeatability limit

The absolute difference between two single results, obtained under repeatability conditions shall not exceed the repeatability limit r , in more than 1 in 20 cases.

$$r = 0,1 \times X_2 \quad (9)$$

6.2.6.2 Reproducibility limit

The absolute difference between two single results, obtained under reproducibility conditions shall not exceed the reproducibility limit R , in more than 1 in 20 cases.

$$R = 0,2 \times X_2 \quad (10)$$

6.3 Water-extractable substances

6.3.1 Principle

A sample of ISFM is maintained in contact with extraction water; the extraction water is drained-off and analyzed for metals, cyanide and PAH. Different procedures are used for granular materials and for powders.

6.3.2 Reagents

All reagents shall be of a recognized analytical grade and the water used shall conform to grade 2 in accordance with EN ISO 3696.

6.3.2.1 Sodium hydrogen carbonate solution, $c(\text{NaHCO}_3) = 0,05 \text{ mol/l}$. Dissolve 4,201 g sodium hydrogen carbonate in water, transfer to a 1 l volumetric flask and dilute to the mark with water.

6.3.2.2 Calcium chloride solution, $c(\text{CaCl}_2 \cdot 2\text{H}_2\text{O}) = 0,03 \text{ mol/l}$. Dissolve 4,411 g calcium chloride dihydrate in water, transfer to a 1 l volumetric flask and dilute to the mark with water.

6.3.2.3 Magnesium sulfate solution, $c(\text{MgSO}_4 \cdot 7\text{H}_2\text{O}) = 0,02 \text{ mol/l}$. Dissolve 4,929 g magnesium sulfate heptahydrate in water, transfer to a 1 l volumetric flask and dilute to the mark with water.

6.3.2.4 Extraction water. To prepare 1 l of extraction water proceed as follows. Into a 1 l volumetric flask add 10,0 ml sodium hydrogen carbonate solution (6.3.2.1), 10,0 ml calcium chloride solution (6.3.2.2) and 10,0 ml magnesium sulfate solution (6.3.2.3), mix and dilute to the mark with water. Measure the pH and, if necessary, adjust to $\text{pH } 7,5 \pm 0,2$ by adding dilute hydrochloric acid or sodium hydroxide solution as necessary.

NOTE 1 The composition of the extraction water is as follows:

- NaHCO_3 : 0,5 mmol/l;
- CaCl_2 : 0,3 mmol/l;
- MgSO_4 : 0,2 mmol/l.

This corresponds to the approximate water analysis:

| Parameter | Units | Value |
|--------------------|---------------------|-------|
| Sodium | mg/l Na | 11,5 |
| Calcium | mg/l Ca | 12,0 |
| Magnesium | mg/l Mg | 5,0 |
| Hydrogen carbonate | mg/l HCO_3 | 30,5 |
| Chloride | mg/l Cl | 21,0 |
| Sulfate | mg/l SO_4 | 19,0 |
| pH | | 7,5 |

NOTE 2 The extraction of substances can vary with the composition of the water. The use of synthetic extraction water is intended to provide a reproducible method for evaluation of different materials but not to indicate exactly the effects that will occur in practice.

6.3.3 Apparatus

Ordinary laboratory apparatus and glassware together with the following.

6.3.3.1 For testing granular materials: Glass column for leaching tests, at least 5 cm in diameter and at least 50 cm in length.

6.3.3.2 For testing powders: Sintered glass filter.

6.3.3.3 Oven capable of being controlled at $(150 \pm 5) ^\circ\text{C}$.

6.3.4 Granular materials

6.3.4.1 Procedure

The test shall be carried out on the material in the form normally supplied by the manufacturer. The ambient temperature shall be maintained at (20 ± 2) °C throughout the test.

Place one bed volume of extraction water (6.3.2.4) in the glass column and leave for 30 min. Collect the water into a glass bottle and retain for analysis; this constitutes the "blank".

Prepare the test sample as follows. Place a sample of ISFM of known mass into the glass column (6.3.3.1) to give a bed depth of at least 30 cm. Add one bed volume of tap water, and leave for (15 ± 1) h to allow the ISFM to become wetted. Backwash using tap water, at a flow rate to give (25 ± 5) % bed expansion, for (30 ± 5) min. Drain the water level with the top of the bed. Rinse the column twice, each time using one bed volume of extraction water (6.3.2.4), allowing a maximum of 10 min for each rinse. Discard the rinse water.

Add a further one bed volume of extraction water and allow to stand for (30 ± 2) min. Drain the water into a glass container; this constitutes the "leachate". Analyse the leachate and the blank using methods of analysis that as a minimum are capable of measuring concentrations in the region of the limit values with trueness, accuracy and limit of detection specified in Table 4.

Table 4 – Requirements to reliability of analytical methods for water-extractable toxic substances

| Chemical | Trueness, % of limit value ^a | Precision, % of limit value ^b | Limit of quantification, % of limit value ^c |
|------------------|--|---|--|
| Antimony | 25 | 25 | 25 |
| Arsenic | 10 | 10 | 10 |
| Cadmium | 10 | 10 | 10 |
| Chromium | 10 | 10 | 10 |
| Lead | 10 | 10 | 10 |
| Mercury | 20 | 10 | 20 |
| Nickel | 10 | 10 | 10 |
| Selenium | 10 | 10 | 10 |
| Cyanide | 10 | 10 | 10 |
| PAH ^d | 25 | 25 | 25 |

^a The difference between the mean value of a large number of measurements and the true value.

^b The standard deviation (within a batch and between batches) of the spread of results about the mean.

^c The lowest concentration of an analyte in a sample that can be determined quantitatively.

NOTE Limit of detection is calculated as 4,65 times the relative within-batch standard deviation of a blank sample.

^d Polycyclic Aromatic Hydrocarbons: fluoranthene, benzo(b)fluoranthene, benzo(k)fluoranthene, benzo(a)pyrene, benzo(ghi)perylene, indeno(1,2,3-cd)pyrene

6.3.4.2 Expression of results

The content of water-extractable substances, X_3 , expressed in micrograms per litre of extractant, is given by the equation:

$$X_3 = C_1 - C_0 \quad (11)$$

where

C_0 is the concentration of water-extractable substances in the blank, in micrograms per litre;

C_1 is the concentration of water-extractable substances in the leachate, in micrograms per litre.

6.3.5 Powders

6.3.5.1 Procedure

The test shall be carried out on the material in the form normally supplied by the manufacturer. The temperature of the test water shall be maintained at (20 ± 2) °C throughout the test.

NOTE 1 The procedure given below is based on the use of 1 l of extraction water. A greater volume of extract can be required in order to perform all the analyses specified in Table 4, in which case a larger volume of extractant, and proportionately higher mass of ISFM, can be used.

Place $(1 \pm 0,01)$ l of extraction water (6.3.2.4) in a glass container and stir continuously for (24 ± 1) h. Pass the water through a separating funnel, collect in a glass bottle and retain for analysis; this constitutes the "blank".

Dry a sample of powdered ISFM to constant mass at 150 °C. Weigh $(10 \pm 0,01)$ g of the dried powdered ISFM (m_1) in the glass container and add 1 l of extraction water (6.3.2.4). Stir the mixture continuously for (24 ± 1) h.

NOTE 2 A high mass of powdered ISFM is used in order to obtain analytically significant results; this dose is over 100 times the highest dose that would be used in the treatment of drinking water.

Transfer to a separating funnel and allow to settle. Filter the supernatant using a sintered glass filter (6.3.3.2) and collect the filtrate in a glass bottle and retain for analysis; this constitutes the "leachate".

Analyze the leachate and the blank using methods of analysis that as a minimum are capable of measuring concentrations in the region of the limit values with trueness, accuracy and limit of detection specified in Table 4.

6.3.5.2 Expression of results

The content of water-extractable substances, X_4 , expressed in milligrams per kilogram of dry product, is given by the following equation:

$$X_4 = \frac{c_1 - c_0}{m_1} \quad (12)$$

where:

C_0 is the concentration, in micrograms per litre, of water-extractable substances in the blank;

C_1 is the concentration, in micrograms per litre, of water-extractable substances in the leachate;

m_1 is the mass, in grams, of the test sample.

6.4 Silica content

6.4.1 Principle

A sample of ISFM is ignited and then digested in sulfuric acid. The residue is ignited again and then digested in hydrofluoric acid. Finally the residue is evaporated to dryness and ignited once more.

6.4.2 Reagents

All reagents shall be of a recognized analytical grade and the water used shall conform to grade 3 in accordance with EN ISO 3696.

6.4.2.1 Sulfuric acid diluted (1 + 1)

Add one volume of sulfuric acid mass fraction of 96 %, $\rho = 1,84$ g/ml, slowly with stirring to one volume of water.

6.4.2.2 Hydrofluoric acid, mass fraction of 40 %, $\rho = 1,13$ g/ml.

SAFETY PRECAUTIONS — Take appropriate safety precautions when handling hydrofluoric acid.

6.4.3 Apparatus

Ordinary laboratory apparatus and glassware together with the following.

6.4.3.1 Platinum dish.

6.4.3.2 Muffle furnace capable of being controlled at (900 ± 25) °C and $(1\ 000 \pm 25)$ °C.

6.4.3.3 Desiccator containing phosphorus pentoxide desiccant.

6.4.3.4 Oven capable of being controlled at (105 ± 2) °C.

6.4.4 Preparation of the sample

Dry a sufficient mass of ISFM at (105 ± 2) °C to constant mass. Return to room temperature in the desiccator (6.4.3.3).

6.4.5 Procedure

Weigh, to the nearest 1 mg, approximately 2 g of the test sample (6.4.4) into the tared platinum dish (6.4.3.1), ignite in the muffle furnace (6.4.3.2) at $(1\ 000 \pm 25)$ °C to constant mass m_1 and cool in the desiccator (6.4.3.3).

Add approximately 1 ml of sulfuric acid (6.4.2.1). Heat the dish gently until fuming ceases and then continue to heat at (900 ± 25) °C for 15 min in the muffle furnace. Remove from the furnace, cool in the desiccator and weigh (m_2).

Add to the residue in the platinum dish 5 ml of the hydrofluoric acid (6.4.2.2) and evaporate to a syrup, taking care to avoid loss by spitting. Cool the dish and wash the sides down with water. Then add 2 ml of hydrofluoric acid (6.4.2.2) and evaporate to dryness. Heat the residue on a hot plate until fumes are no longer evolved, then ignite in the muffle furnace to (900 ± 25) °C for 15 min. Remove the dish from the furnace, cool in the desiccator and determine the mass m_3 .

6.4.6 Expression of results

The silica content (X_5) expressed as mass fraction is calculated using the following equation:

$$X_5 = \frac{(m_2 - m_3)}{m_1} \times 100 \quad (13)$$

where

m_1 is the mass of ignited residue, in grams;

m_2 is the mass after treatment with sulfuric acid and ignition, in grams;

m_3 is the mass after treatment with hydrofluoric acid and ignition, in grams.

6.5 Water content (mass loss at 105 °C or 150 °C)

6.5.1 Principle

Drying the sample to constant mass at 105 °C, or 150 °C for porous materials. It is assumed that water is the only material present in the ISFM which is volatile at this temperature.

6.5.2 Apparatus

Ordinary laboratory apparatus and glassware together with the following.

6.5.2.1 Drying oven capable of being controlled at (105 ± 2) °C or (150 ± 5) °C.

6.5.2.2 Squat form glass weighing bottle with ground stopper or seamless metal crucible with lid, as shallow as possible consistent with convenient handling.

6.5.2.3 Desiccator.

6.5.2.4 Analytical balance, having an accuracy of $\pm 0,1$ mg.

6.5.3 Procedure

Place a 1 g to 2 g sample of ISFM into a pre-dried tared weighing bottle or crucible (6.5.2.2.); the depth of the ISFM in the container should not exceed 1,25 cm. Close the container and weigh immediately to the nearest 0,5 mg; note the mass m_1 . Remove the lid and place the container and lid in the pre-heated drying oven (6.5.2.1) at (105 ± 2) °C, or (150 ± 5) °C for porous materials. Leave until constant mass is attained. Open the oven and close the container quickly, transfer to the desiccator (6.5.2.3) and allow to cool to room temperature. When cool weigh to the nearest 0,5 mg; note the mass m_2 .

NOTE It can be necessary, for certain materials that are of large particle size or inhomogeneous, to use a larger sample and greater depth of material in the container.

6.5.4 Expression of results

The water content, X_6 , expressed in mass fraction of as-received product, is given by the equation:

$$X_6 = \frac{(m_1 - m_2)}{(m_1 - m_0)} \times 100 \quad (14)$$

where

m_0 is the mass of the empty container and lid, in grams;

m_1 is the mass of the container with lid plus sample, in grams;

m_2 is the mass of the container and lid plus dried sample, in grams.

6.6 Content of carbon (C)

The content of carbon shall be determined in accordance with ISO 609.

6.7 Content of volatile matter

The content of volatile matter shall be determined in accordance with ISO 562.

6.8 Water-soluble material

6.8.1 General

This method is applicable to determination of the content of water-soluble material in powdered activated carbon and granular activated carbon.

6.8.2 Principle

A pulverized sample of activated carbon is extracted with hot water. The extract is evaporated to dryness and weighed.

6.8.3 Reagents

All reagents shall be of a recognized analytical grade and the water used shall conform to grade 3 in accordance with EN ISO 3696.

6.8.4 Apparatus

Ordinary laboratory apparatus and glassware together the following.

6.8.4.1 Extraction apparatus comprising 250 ml flat bottomed flask with ground joint 29/32 fitted with water cooled reflux condenser (length 300 mm minimum).

6.8.4.2 Filtration apparatus comprising glass or porcelain Buchner funnel, 75 mm diameter, with 500 ml receiving flask.

6.8.4.3 Filter papers, ash free, high retention, 70 mm.

6.8.4.4 Steam bath.

6.8.4.5 Drying oven capable of being controlled at $(150 \pm 5) ^\circ\text{C}$.

6.8.4.6 Evaporating dish of glass, silica or platinum, 90 ml capacity.

6.8.4.7 Desiccator.

6.8.4.8 Analytical balance, having an accuracy of $\pm 0,1$ mg.

6.8.4.9 Hotplate.

6.8.5 Procedure

Take an adequate sample of activated carbon and if necessary grind to less than 0,1 mm. Dry to constant mass at 150 °C. Weigh 10 g, to the nearest of 0,01 g, of the dried pulverized carbon into the flask. Add 100 ml of water, mix the contents and connect the flask to the condenser (6.8.4.1). Bring to the boil on the hotplate (6.8.4.9) and reflux for 1 h.

Just before the end of the boiling period, prepare the filter as follows. Wet the filter paper (6.8.4.3) with water and position the filter paper on the funnel (6.8.4.2), applying gentle suction to obtain a leak-free filter. Switch off the hotplate, rinse the condenser into the flask with a little water and disconnect the flask from the condenser. Transfer the carbon slurry as hot as possible onto the filter in one operation. Rinse the flask with three 25 ml portions of water and add the rinsings to the filter. Drain the carbon cake fully by suction, cool the filtrate to ambient temperature and transfer it quantitatively to a 250 ml volumetric flask. Fill to the mark with water and mix.

Weigh a dry and clean evaporating dish (6.8.4.6) to the nearest 0,1 mg. Pipette 50 ml of the water extract into the dish and evaporate to dryness on a steam bath (6.8.4.4) in a well-ventilated fume cupboard. Place the dish in the oven (150 °C) (6.8.4.5) for 3 h and re-weigh after cooling in a desiccator (6.8.4.7) for 15 min. Repeat the drying with 1 h intervals until constant mass is obtained ($\pm 0,2$ mg).

6.8.6 Expression of results

The content of water-soluble material, X_7 , expressed as mass fraction of dry product, is given by the following equation:

$$X_7 = \frac{100 \times (m_1 - m_0)}{2} \quad (15)$$

where

m_0 is the mass, in grams, of the empty evaporating dish;

m_1 is the mass, in grams, of the evaporating dish plus dried water extract.

6.8.7 Precision

6.8.7.1 Repeatability limit

The absolute difference between two single results, obtained under repeatability conditions, shall not exceed the repeatability limit, r , in more than 1 in 20 cases.

$$r = 0,3 \times X_7 \quad (16)$$

6.8.7.2 Reproducibility limit

The absolute difference between two single results, obtained under reproducibility conditions, shall not exceed the reproducibility limit, R in more than 1 in 20 cases.

$$R = 0,5 \times X_7 \quad (17)$$

6.9 Content of zinc

6.9.1 General

This method is applicable to determination of the content of zinc in powdered activated carbon and granular activated carbon.

6.9.2 Principle

A pulverized sample of activated carbon is extracted with boiling hydrochloric acid and the zinc concentration in the extract is determined by atomic absorption spectrometry.

6.9.3 Reagents

All reagents shall be of a recognized analytical grade and the water used shall conform to grade 2 in accordance with EN ISO 3696.

6.9.3.1 Hydrochloric acid, concentrated ($\rho = 1,18$ g/ml).

6.9.3.2 Hydrochloric acid, $c(\text{HCl}) = 5$ mol/l. Dilute 442 ml of concentrated hydrochloric acid ($\rho = 1,18$ g/ml) to 1 l with water and mix thoroughly.

6.9.3.3 Zinc standard solution containing 1,000 g of zinc per litre. Dissolve 1,000 g of granulated zinc in 20 ml of 5 mol/l hydrochloric acid (6.9.3.2), dilute with water to 1 l.

6.9.3.4 Zinc standard solution containing 100 mg of zinc per litre, prepared by dilution of solution 6.9.3.3.

6.9.4 Apparatus

Ordinary laboratory apparatus and glassware together with the following.

6.9.4.1 Extraction apparatus comprising 250 ml flat bottomed flask with ground joint 29/32, fitted with water cooled reflux condenser (length 300 mm minimum).

6.9.4.2 Filtration apparatus comprising glass or porcelain Buchner funnel, 75 mm diameter, with 500 ml receiving flask.

6.9.4.3 Filter papers, ash free, high retention, 70 mm.

6.9.4.4 Drying oven capable of being controlled at (150 ± 5) °C.

6.9.4.5 Desiccator.

6.9.4.6 Analytical balance, having an accuracy of $\pm 0,1$ mg.

6.9.4.7 Hotplate.

6.9.4.8 Atomic absorption spectrometer fitted with an acetylene-air burner and a non-specific absorbance correction system. The spectrometer used shall be capable of detection of 0,2 mg/l of zinc in solution.

6.9.4.9 Zinc hollow cathode lamp.

6.9.5 Procedure

6.9.5.1 Test solution

If necessary grind to less than 0,1 mm a sample of activated carbon. Dry to constant mass at 150 °C. Weigh 10 g to the nearest of 0,001 g, of the dried carbon into the flask. Add 100 ml of water and mix. Add 10 ml of concentrated hydrochloric acid (6.9.3.1), mix the contents and connect the flask to the condenser (6.9.4.1). Bring to the boil on the hotplate (6.9.4.7) and reflux for 1 h.

Prepare the filter as follows. Wet the filter paper (6.9.4.3) with water and position the filter paper on the funnel (6.9.4.2), applying gentle suction to obtain a leak-free filter. Switch off the hotplate, rinse the condenser into the flask with a little water and disconnect the flask from the condenser. Transfer the carbon slurry onto the filter, rinse the flask with three 25 ml portions of water and add the rinsings to the filter. Drain the carbon cake fully by suction.

Cool the filtrate to ambient temperature and transfer it quantitatively to a 250 ml volumetric flask, fill to the mark with water and mix.

6.9.5.2 Blank test

Perform a blank test following the same procedure and using the same quantities of all the reagents.

6.9.5.3 Preparation of calibration solutions

To a series of six 50 ml volumetric flasks add 0,0 ml, 0,1 ml, 0,2 ml, 0,3 ml, 0,4 ml and 0,5 ml of the standard zinc solution (6.9.3.4). Add 2,0 ml of concentrated hydrochloric acid (6.9.3.1), fill to the mark with water and mix.

These calibration solutions contain 0 mg/l, 0,2 mg/l, 0,4 mg/l, 0,6 mg/l, 0,8 mg/l and 1,0 mg/l of zinc.

6.9.5.4 Preparation of the atomic absorption spectrometer

Fit the zinc hollow cathode lamp (6.9.4.9) to the apparatus (6.9.4.8) and apply current for the time needed for its stabilization. Adjust the current supplying the lamp, the sensitivity and the slit according to the manufacturer's instructions. Regulate the wavelength at around 214 nm to obtain maximum energy. Light the burner.

Regulate the position of the lamp and burner as well as the acetylene and air flows according to the nature of the equipment in order to obtain the maximum response.

6.9.5.5 Spectrometric measurements

Use the non-specific absorbance correction device. Set the absorbance zero of the apparatus using water as the reference. Introduce each of the calibration solutions into the flame three times and record the steady reading, washing the apparatus through with water after each introduction. Prepare a calibration curve by plotting the mean of each group of three readings against the concentration. Introduce the test solution (6.9.5.1) into the flame, record the reading and wash the apparatus through with water. Repeat this procedure twice and, using the mean of the three readings, determine the concentration of zinc from the calibration curve. Analyse the blank solution (6.9.5.2) in the same way.

6.9.6 Expression of results

The zinc content, X_8 , expressed as mass fraction, is given by the following equation:

$$X_8 = \frac{(c_2 - c_1)}{(m_0 \times 40)} \quad (18)$$

where

m_0 is the mass, in grams, of the sample;

c_1 is the concentration, in milligrams per litre, of zinc in the analyzed blank solution;

c_2 is the concentration, in milligrams per litre, of zinc in the analyzed test solution.

6.9.7 Repeatability limit

The absolute difference between two single results, obtained under repeatability conditions, shall not exceed the repeatability limit, r , in more than 1 in 20 cases.

$$r = 0,15 \times X_8 \quad (19)$$

6.10 Iodine number

6.10.1 General

This method is applicable to determination of the Iodine Number of powdered activated carbon and granular activated carbon. The iodine number is defined as the mass (in milligrams) of iodine adsorbed from an aqueous solution of iodine by 1 g of activated carbon when the iodine concentration of the residual filtrate, $c(I_2)$, is 0,01 mol/l.

6.10.2 Principle

A standard solution of iodine is treated with three different amounts of activated carbon, filtered and analysed for residual iodine content. The results are used to construct a three-point adsorption isotherm from which the iodine number is determined.

6.10.3 Reagents

All reagents shall be of a recognized analytical grade and the water used shall conform to grade 3 in accordance with EN ISO 3696.

6.10.3.1 Hydrochloric acid, mass fraction 5 %.

Add 70 ml of concentrated hydrochloric acid ($\rho = 1,18$ g/ml) to 550 ml of water and mix thoroughly.

6.10.3.2 Sodium thiosulfate solution, $c(Na_2S_2O_3) = 0,1$ mol/l.

Dissolve 24,820 g of sodium thiosulfate pentahydrate, $Na_2S_2O_3 \cdot 5H_2O$, in (75 ± 25) ml of freshly boiled and cooled water. Add $(0,10 \pm 0,01)$ g of sodium carbonate (to minimize bacterial decomposition), transfer to a 1 l volumetric flask and dilute to the mark. Store the solution in an amber coloured bottle, and allow to stand for at least 4 d before standardizing.

6.10.3.3 Iodine solution, $c(I_2) = 0,05 \text{ mol/l}$.

Weigh 12,690 g iodine and 19,100 g potassium iodide into a beaker, mix dry then add 2 ml to 5 ml of water and stir thoroughly. Continue adding small increments of water (approximately 5 ml) while stirring until the total volume is 50 ml to 60 ml. Allow to stand, with occasional stirring, for at least 4 h to ensure complete dissolution. Transfer to a 1 l volumetric flask and dilute to the mark with water. Store in an amber coloured bottle.

6.10.3.4 Potassium iodate solution, $c(1/6 \text{ KIO}_3) = 0,10 \text{ mol/l}$.

Dry at least 4 g potassium iodate at $(110 \pm 5) \text{ }^\circ\text{C}$ for 2 h and cool to room temperature in a desiccator. Dissolve $3,5667 \text{ g} \pm 0,1 \text{ mg}$ of the dry potassium iodate in about 100 ml of water. Transfer to a 1 l volumetric flask, dilute to the mark with water and mix thoroughly. Store in a glass-stoppered bottle.

6.10.3.5 Starch solution.**6.10.3.6** Potassium iodide.**6.10.3.7** Sodium carbonate.**6.10.4 Apparatus**

Ordinary laboratory apparatus and glassware together the following.

6.10.4.1 Glass stoppered 250 ml conical flasks.**6.10.4.2** Folded filters, 8 μm pore size, 18 cm diameter.**6.10.4.3** Hotplate.**6.10.4.4** Analytical balance, having an accuracy of $\pm 0,1 \text{ mg}$.**6.10.4.5** Oven capable of being controlled at $(150 \pm 5) \text{ }^\circ\text{C}$.**6.10.5 Procedure****6.10.5.1 Standardization of solutions****6.10.5.1.1 Standardization of sodium thiosulfate**

Pipette 25,0 ml potassium iodate solution (6.10.3.4) into a titration flask, add $(2 \pm 0,01) \text{ g}$ of potassium iodide to the flask and shake to dissolve the potassium iodide. Pipette 5,0 ml of concentrated hydrochloric acid ($\rho = 1,18 \text{ g/ml}$) into the flask, and titrate the liberated iodine with sodium thiosulfate solution (6.10.3.2) until a light yellow solution is observed, then add a few drops of starch indicator (6.10.3.5) and complete the titration dropwise until one drop produces a colourless solution.

The concentration of the sodium thiosulfate solution (in moles per litre) is calculated from the following equation:

$$c(\text{Na}_2\text{S}_2\text{O}_3) = \frac{2,5}{V_1} \quad (20)$$

where

V_1 is the volume, in millilitres, of sodium thiosulfate solution used in the titration.

Use the mean of three titrations.

6.10.5.1.2 Standardization of iodine

Pipette 25,0 ml iodine solution (6.10.3.3) into a titration flask. Titrate with standardized sodium thiosulfate solution (6.10.3.2) until the colour of the iodine solution is a light yellow. Add a few drops of starch indicator (6.10.3.5) and complete the titration dropwise until one drop produces a colourless solution.

The concentration of the iodine solution, $c(I_2)$ (in moles per litre), is calculated from the following equation:

$$c(I_2) = \frac{(V_2 \times c(\text{Na}_2\text{S}_2\text{O}_3))}{(V_3 \times 2)} \quad (21)$$

where

V_2 is the volume, in millilitres, of sodium thiosulfate solution used in the titration;

V_3 is the volume, in millilitres, of iodine solution.

Use the mean of three titrations.

If the iodine solution concentration, $c(I_2)$, is not $(0,050 \pm 0,001)$ mol/l then prepare and standardize a fresh solution.

6.10.5.2 Determination of iodine number

The determination of the iodine number requires an estimation of three carbon doses as described in 6.10.6.2.

Take an adequate sample of activated carbon, grind if necessary until at least a mass fraction of 95 % will pass through a 45 μm test sieve, and dry to constant mass at 150 °C.

After estimating carbon doses, weigh three appropriate amounts of the dried carbon to the nearest 1 mg. Transfer each weighed sample into a dry, glass stoppered 250 ml conical flask (6.10.4.1).

Pipette 10,0 ml of hydrochloric acid (6.10.3.1) into each flask, stopper the flasks and swirl until the activated carbon is wetted. Loosen the stoppers to vent the flasks, place on a hotplate (6.10.4.3) in a fume cupboard, and bring the contents to the boil. Allow to boil gently for (30 ± 2) s. Remove the flasks and cool to room temperature. Pipette 100,0 ml of 0,05 mol/l iodine solution (6.10.3.3), standardized just before use, into each flask. Stagger the addition of the iodine so that no delays are encountered in handling. Stopper the flasks immediately, shake vigorously for (30 ± 1) s, then immediately filter under gravity through a prepared folded filter paper (6.10.4.2).

Discard the first 20 ml to 30 ml of filtrate and collect the remainder in a clean beaker. Stir the filtrate in the beaker with a glass rod and pipette 50,0 ml into a 250 ml conical flask.

Titrate each 50 ml sample of filtrate with 0,10 mol/l sodium thiosulfate solution (6.10.3.2) until the yellow colour has almost disappeared. Add 2 ml of starch solution (6.10.3.5) and continue titration until the blue colour just disappears. Record the volume (V_4) of sodium thiosulfate solution used.

6.10.6 Expression of results

6.10.6.1 Calculation

For each carbon dose, calculate iodine loading (X / M) and residual iodine concentration (C) using the following equations:

$$\frac{X}{M} = \frac{(c(I_2) \times 200 - 2,2 \times c(\text{Na}_2\text{S}_2\text{O}_3) \times V_4) \times 126,9}{m_1} \quad (22)$$

and

$$C = \frac{c(\text{Na}_2\text{S}_2\text{O}_3) \times V_4}{100} \quad (23)$$

where

X / M is the mass, in milligrams, of iodine adsorbed per gram of carbon;

$c(I_2)$ is the concentration, in moles per litre, of iodine from 6.10.5.1.2;

2,2 is the dilution factor: $\frac{(100 + 10)}{50} = 2,2$ for 10 ml hydrochloric acid and 50 ml of filtrate;

$c(\text{Na}_2\text{S}_2\text{O}_3)$ is the concentration, in moles per litre, of sodium thiosulfate from 6.10.5.1.1;

V_4 is the volume, in millilitres, of sodium thiosulfate solution used in the titration;

126,9 is the relative atomic mass of iodine;

m_1 is the mass, in grams, of carbon used in the test.

If the values of C are not within the range 0,004 mol/l to 0,020 mol/l, repeat the procedure using different amounts of carbon.

Using logarithmic paper, plot X / M as the ordinate versus C as the abscissa for each of the three carbon doses. Calculate the least squares fit for the three points and plot the line.

X_9 , the iodine number, is the X / M value at a residual iodine concentration, C , of 0,01 mol/l.

The regression coefficient for the least squares fit shall be greater than 0,995.

6.10.6.2 Estimation of carbon doses

The carbon dose shall be estimated using the following equation:

$$m_1 = \frac{(c(I_2) \times 200 - 2,2 \times C \times 50) \times 126,9}{X_E} \quad (24)$$

where

- m_1 is the mass, in grams, of carbon to be used in the test;
- $c(I_2)$ is the concentration, in moles per litre, of iodine from 6.10.5.1.2;
- 2,2 is the dilution factor: see 6.10.6.1
- C is the residual iodine concentration, in moles per litre, values of 0,005 mol/l, 0,010 mol/l and 0,015 mol/l are usually taken;
- 126,9 is the relative atomic mass of iodine
- X_E is the expected iodine number.

Calculate three carbon doses corresponding to three values of C (0,005 mol/l, 0,010 mol/l and 0,015 mol/l).

6.10.7 Precision**6.10.7.1 Repeatability limit**

The absolute difference between two single results, obtained under repeatability conditions, shall not exceed the repeatability limit, r , in more than 1 in 20 cases (for X_9 in the range 600 to 1450).

$$r = 0,08 \times X_9 \quad (25)$$

6.10.7.2 Reproducibility limit

The absolute difference between two single results, obtained under reproducibility conditions, shall not exceed the value, R in more than 1 in 20 cases (for X_9 in the range 600 to 1450).

$$R = 0,14 \times X_9 \quad (26)$$

Annex A (informative)

Measurement of resistance to friability

A.1 General

This method is applicable to determination of the friability of ISFM of artificial or natural origin, with the exclusion of powders.

A.2 Principle

Rotation of a drum containing the ISFM and steel balls. After this crushing operation, the changes in the values of some parameters read on the cumulative particle size distribution curve of the ISFM are measured.

A.3 Apparatus

A.3.1 Crushing apparatus

The crushing apparatus is shown in Figure A.1 and comprises the following.

- a) Circular disk, diameter 34 cm, which can rotate around a central horizontal axis; a device for attaching the crushing drum is attached radially to the disk, with a counter weight attached diametrically opposite it (see Figure A.1).
- b) Drive system: electric motor with speed reduction system to achieve speed of (25 ± 2) rpm. A totalizing revolution counter counts the exact number of revolutions.
- c) Steel drum, internal diameter (42 ± 1) mm, useful internal length (100 ± 1) mm, fixed radially to the disk. The drum has a screw-on steel lid for loading steel balls and ISFM.
- d) mild steel spherical balls (density: $7,80 \text{ g/cm}^3$), diameter $(12^{+0,1}_{-0,4})$ mm. The total mass of balls is (126^{+2}_{-10}) g.

A.3.2 Sieving apparatus

Equipment for carrying out a particle size distribution analysis in accordance with ISO 2591-1.

A.3.3 Oven capable of being controlled at (105 ± 2) °C.

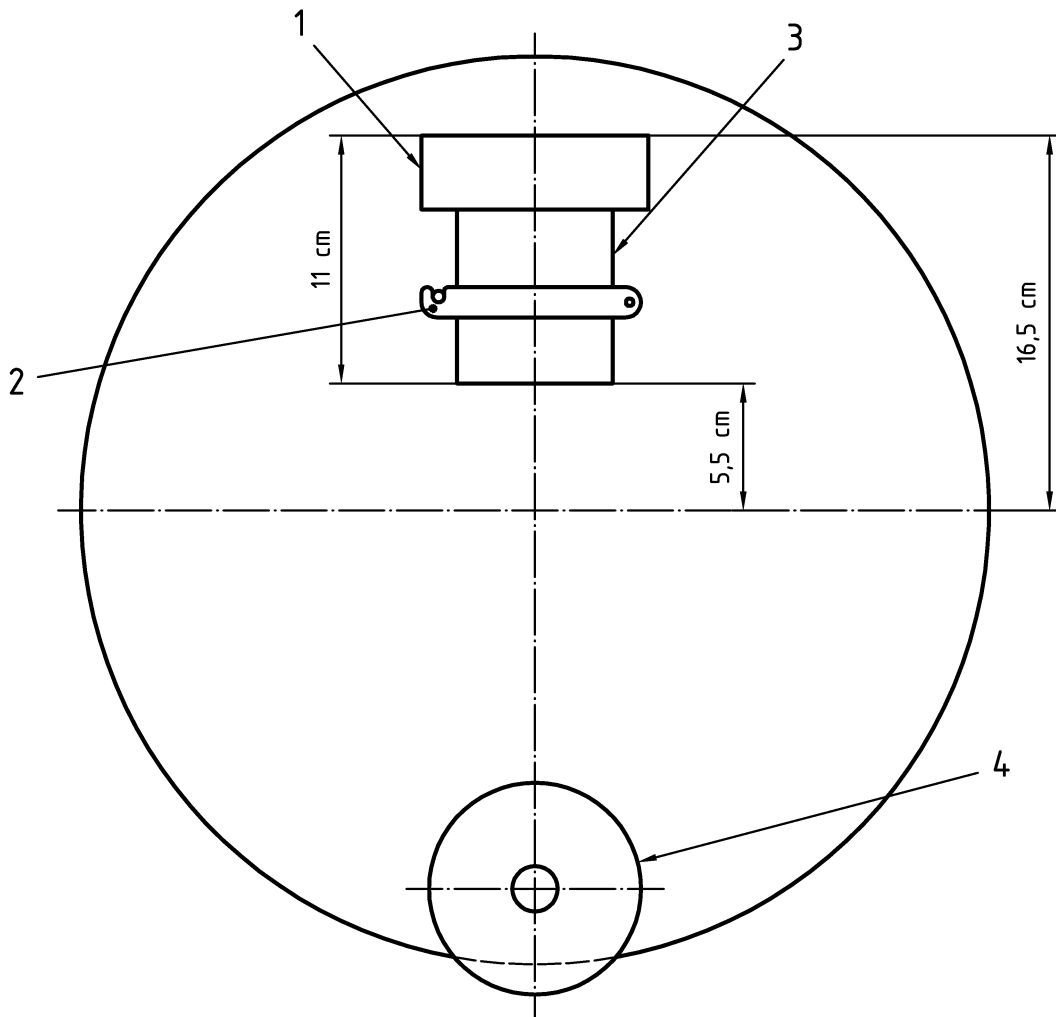

Key

- 1 screw-on lid
- 2 retaining lug
- 3 crushing drum
- 4 counter weight

Figure A.1 – Crushing apparatus

A.4 Preparation of sample

From a representative portion of the initial sample, dry a sufficient volume of ISFM at 105 °C to constant mass. Determine the particle size distribution according to 5.1. Take a test portion of 35 ml and weigh it to the nearest 1 % mass fraction.

A.5 Procedure

A.5.1 750 impacts

Place the balls in the upright test drum (opening pointing upwards). Then add the 35 ml of ISFM (A.4). Screw on the lid. Rotate the drum at 25 rpm for 15 min (375 revolutions, 750 impacts). Perform particle size distribution analysis using the same sieves and in the same conditions as A.4 and plot the cumulative particle size distribution. Clean ISFM from the sieves and from the bottom of the drum and collect.

A.5.2 1 500 impacts

Repeat all procedures described in A.5.1, using the ISFM collected after 750 impacts. Total drum rotation time is 30 min (750 revolutions, 1 500 impacts).

A.6 Expression of results

From the particle size distribution curves before and after crushing (Figure A.2) determine:

- the percentage loss compared with the minimum size d_1 before crushing;
- the percentage loss compared with the effective size d_{10} before crushing.

Example (see Figure A.2)

- X_1 is the percentage of particles corresponding to the minimum size d_1 after crushing, before crushing the percentage is 1. Thus the percentage lost is:

$$X_1 - 1 = 22 - 1 = 21 \text{ percent}$$

- X_2 is the percentage of particles corresponding to the effective size d_{10} after crushing, before crushing the percentage is 10. Thus the percentage lost is:

$$X_2 - 10 = 33 - 10 = 23 \text{ percent}$$

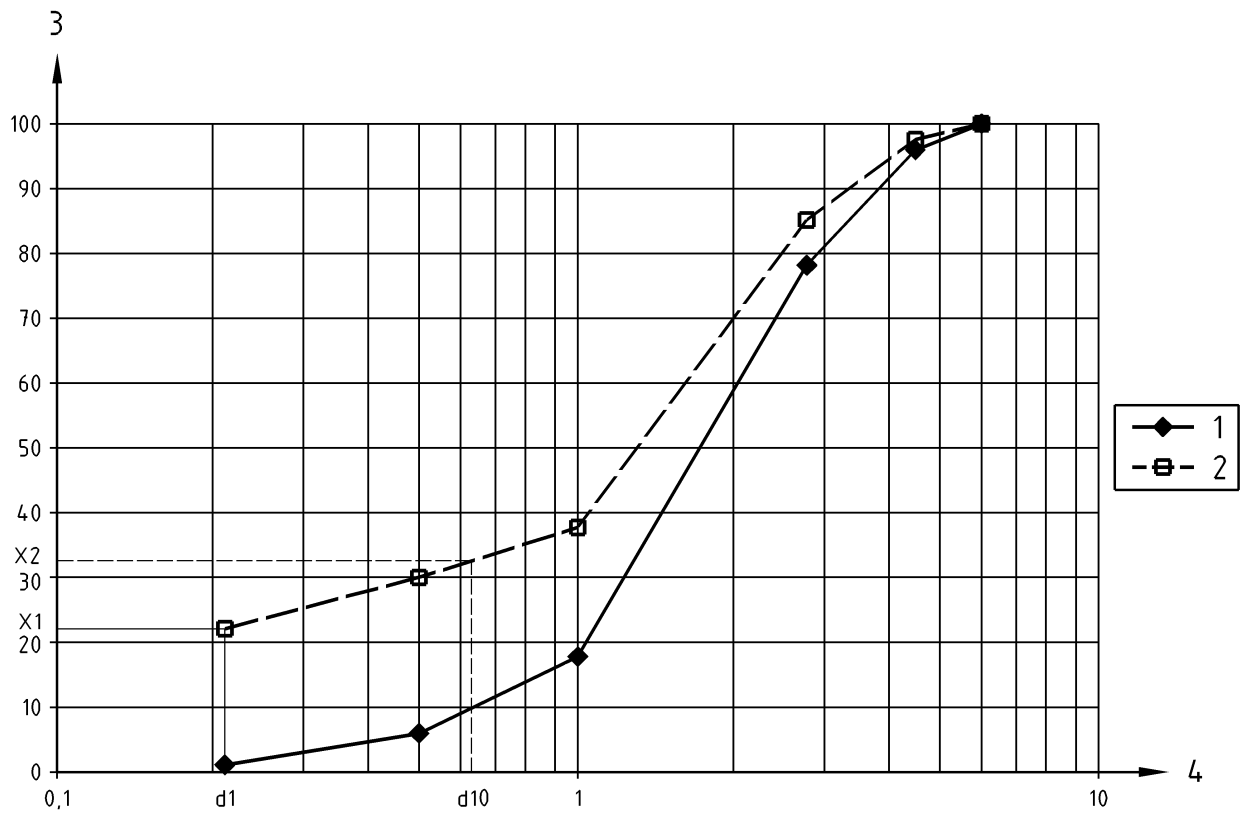

Key

- 1 Before crushing
- 2 After crushing
- 3 Cumulative percent by mass passing
- 4 Particle size in millimetres

Figure A.2 – Example of friability test results

BSI — British Standards Institution

BSI is the independent national body responsible for preparing British Standards. It presents the UK view on standards in Europe and at the international level. It is incorporated by Royal Charter.

Revisions

British Standards are updated by amendment or revision. Users of British Standards should make sure that they possess the latest amendments or editions.

It is the constant aim of BSI to improve the quality of our products and services. We would be grateful if anyone finding an inaccuracy or ambiguity while using this British Standard would inform the Secretary of the technical committee responsible, the identity of which can be found on the inside front cover.
Tel: +44 (0)20 8996 9000. Fax: +44 (0)20 8996 7400.

BSI offers members an individual updating service called PLUS which ensures that subscribers automatically receive the latest editions of standards.

Buying standards

Orders for all BSI, international and foreign standards publications should be addressed to Customer Services. Tel: +44 (0)20 8996 9001.
Fax: +44 (0)20 8996 7001. Email: orders@bsi-global.com. Standards are also available from the BSI website at <http://www.bsi-global.com>.

In response to orders for international standards, it is BSI policy to supply the BSI implementation of those that have been published as British Standards, unless otherwise requested.

Information on standards

BSI provides a wide range of information on national, European and international standards through its Library and its Technical Help to Exporters Service. Various BSI electronic information services are also available which give details on all its products and services. Contact the Information Centre.
Tel: +44 (0)20 8996 7111. Fax: +44 (0)20 8996 7048. Email: info@bsi-global.com.

Subscribing members of BSI are kept up to date with standards developments and receive substantial discounts on the purchase price of standards. For details of these and other benefits contact Membership Administration.
Tel: +44 (0)20 8996 7002. Fax: +44 (0)20 8996 7001.
Email: membership@bsi-global.com.

Information regarding online access to British Standards via British Standards Online can be found at <http://www.bsi-global.com/bsonline>.

Further information about BSI is available on the BSI website at <http://www.bsi-global.com>.

Copyright

Copyright subsists in all BSI publications. BSI also holds the copyright, in the UK, of the publications of the international standardization bodies. Except as permitted under the Copyright, Designs and Patents Act 1988 no extract may be reproduced, stored in a retrieval system or transmitted in any form or by any means – electronic, photocopying, recording or otherwise – without prior written permission from BSI.

This does not preclude the free use, in the course of implementing the standard, of necessary details such as symbols, and size, type or grade designations. If these details are to be used for any other purpose than implementation then the prior written permission of BSI must be obtained.

Details and advice can be obtained from the Copyright & Licensing Manager.
Tel: +44 (0)20 8996 7070. Fax: +44 (0)20 8996 7553.
Email: copyright@bsi-global.com.