

Trenchless construction and testing of drains and sewers

The European Standard EN 12889:2000 has the status of a
British Standard

ICS 93.030;

National foreword

This British Standard is the official English language version of EN 12889:2000.

The UK participation in its preparation was entrusted by Technical Committee B/505, Wastewater engineering, to Subcommittee B/504/505/1, Structural design of buried pipelines, which has the responsibility to:

- aid enquirers to understand the text;
- present to the responsible European committee any enquiries on the interpretation, or proposals for change, and keep the UK interests informed;
- monitor related international and European developments and promulgate them in the UK.

A list of organizations represented on this subcommittee can be obtained on request to its secretary.

Cross-references

The British Standards which implement international or European publications referred to in this document may be found in the BSI Standards Catalogue under the section entitled “International Standards Correspondence Index”, or by using the “Find” facility of the BSI Standards Electronic Catalogue.

A British Standard does not purport to include all the necessary provisions of a contract. Users of British Standards are responsible for their correct application.

Compliance with a British Standard does not of itself confer immunity from legal obligations.

Summary of pages

This document comprises a front cover, an inside front cover, the EN title page, pages 2 to 22, an inside back cover and a back cover.

The BSI copyright notice displayed in this document indicates when the document was last issued.

This British Standard, having been prepared under the direction of the Sector Committee for Building and Civil Engineering, was published under the authority of the Standards Committee and comes into effect on 15 June 2000

© BSI 06-2000

ISBN 0 580 36023 7

Amendments issued since publication

Amd. No.	Date	Comments

EUROPEAN STANDARD

EN 12889

NORME EUROPÉENNE

EUROPÄISCHE NORM

January 2000

ICS 93.030

English version

Trenchless construction and testing of drains and sewers

Mise en oeuvre sans tranchée et essai des branchements
et collecteurs d'assainissement

Grabenlose Verlegung und Prüfung von Abwasserleitungen
und -kanälen

This European Standard was approved by CEN on 15 November 1999.

CEN members are bound to comply with the CEN/CENELEC Internal Regulations which stipulate the conditions for giving this European Standard the status of a national standard without any alteration. Up-to-date lists and bibliographical references concerning such national standards may be obtained on application to the Central Secretariat or to any CEN member.

This European Standard exists in three official versions (English, French, German). A version in any other language made by translation under the responsibility of a CEN member into its own language and notified to the Central Secretariat has the same status as the official versions.

CEN members are the national standards bodies of Austria, Belgium, Czech Republic, Denmark, Finland, France, Germany, Greece, Iceland, Ireland, Italy, Luxembourg, Netherlands, Norway, Portugal, Spain, Sweden, Switzerland and United Kingdom.



EUROPEAN COMMITTEE FOR STANDARDIZATION
COMITÉ EUROPÉEN DE NORMALISATION
EUROPÄISCHES KOMITEE FÜR NORMUNG

Central Secretariat: rue de Stassart, 36 B-1050 Brussels

Contents

	Page
Foreword	3
1 Scope	4
2 Normative references	4
3 Definitions	4
4 General	5
5 Construction components and materials	5
5.1 General	5
5.2 Pipes and joints	5
5.3 Manholes and inspection chambers	6
5.4 Delivery, handling and transportation on site	6
5.5 Storage	6
6 Techniques	6
6.1 Unmanned techniques	8
6.2 Manned techniques	15
7 Requirements	15
7.1 Safeguarding design assumptions	15
7.2 Special requirements	15
7.3 Safeguarding design assumptions	15
7.4 Information about ground conditions	16
7.5 Data collection during installation	16
7.6 Stability during construction	17
7.7 Overcut	17
7.8 Overbreak	17
7.9 Settlement and heave	17
7.10 Deviation in line and level	17
8 Inspection and/or testing of pipelines after installation	17
8.1 Visual inspection	18
8.2 Leaktightness	18
9 Procedures and requirements for testing gravity pipelines	18
9.1 General	18
9.2 Testing with air (method "L")	18
9.3 Testing with water (method "W")	21
9.4 Testing of each individual joint	21
10 Testing of pressure pipelines	21
11 Qualification	21
Annex A (informative) Abstract from Council Directive of 17 September 1990 on the procurement procedures of entities operating in the water, energy, transport and telecommunication sectors	22

Foreword

This European Standard has been prepared by Technical Committee CEN/TC 165, Waste water engineering, the Secretariat of which is held by DIN.

This European Standard shall be given the status of a national standard, either by publication of an identical text or by endorsement, at the latest by July 2000, and conflicting national standards shall be withdrawn at the latest by July 2000.

According to the CEN/CENELEC Internal Regulations, the national standards organizations of the following This European Standard has countries are bound to implement this European Standard: Austria, Belgium, Czech Republic, Denmark, Finland, France, Germany, Greece, Iceland, Ireland, Italy, Luxembourg, Netherlands, Norway, Portugal, Spain, Sweden, Switzerland and the United Kingdom.

Annex A is informative.

1 Scope

This European Standard is applicable to the trenchless construction and testing of new drains and new sewers in the ground, which are normally operating as gravity pipelines, formed using prefabricated pipes and their joints. The trenchless construction and testing of drains and sewers operating under pressure is also covered by this European Standard together with prEN 805:1999 as appropriate.

This European Standard also applies to trenchless replacement techniques. Renovation techniques for existing sewers and drains are not covered by this European Standard.

Methods of trenchless construction include

- manned and unmanned techniques;
- steerable and non-steerable techniques.

NOTE 1: Mining or tunnelling (e.g. in situ construction or the use of prefabricated segments) are not covered by this European Standard although some parts may apply to these methods. Additional requirements apply for mining and tunnelling methods for the construction of drains and sewers.

Additionally other local or national regulations should be taken into account, e.g. concerning health and safety, pavement installation, tolerances for deviation in line and level and requirements for leaktightness testing.

NOTE 2: Requirements for associated pipeline installation work other than trenchless construction, e.g. for manholes and inspection chambers, are given in EN 1610, Construction and testing of drains and sewers.

2 Normative references

This European Standard incorporates by dated or undated reference, provisions from other publications. These normative references are cited at the appropriate places in the text and the publications are listed hereafter. For dated references, subsequent amendments to or revisions of any of these publications apply to this European Standard only when incorporated in it by amendment or revision. For undated references the latest edition of the publication referred to applies.

EN 752-5:1997
Drain and sewer systems outside buildings – Part 5: Rehabilitation

prEN 805:1999
Water supply – Requirements for systems and components outside buildings

3 Definitions

For the purposes of this European Standard the following definitions apply.

3.1 cutting head a tool or system of tools on a common support, which excavates at the face of a bore. The term usually applies to mechanical methods of excavation

3.2 expander a tool which enlarges a bore by displacement of the surrounding ground rather than by excavation

3.3 gravity pipeline pipeline where flow is caused by the force of gravity and where the pipeline is designed normally to operate partially full

3.4 overbreak the extent by which the excavated void including accidental ground losses initially exceeds the outside dimension of the pipe

3.5 overcut the annular space around the pipe deliberately created by using a cutting head or shield of greater dimension than the outside dimension of the pipe

3.6 pipe jacking a system of directly installing pipes behind a cutting head and/or shield, by hydraulic jacking from a drive shaft, such that the pipes form a string in the ground

3.7 reamer a cutting head attached to the end of a drill string or pilot rod to enlarge the pilot diameter during a pull-back or pushing operation, to enable a pipe or pipes to be installed

3.8 renovation work incorporating all or part of the original fabric of the pipeline by means of which its current performance is improved (EN 752-5:1997)

3.9 replacement construction of a new drain or sewer, on or off the line of an existing drain or sewer, the function of the new drain or sewer incorporating that of the old (EN 752-5:1997)

3.10 spoil material excavated and removed in the course of installation

3.11 trenchless construction technique any technique for constructing pipelines in the ground without opening trenches

3.12 manned technique technique involving the use of personnel working in the excavated bore during installation

3.13 unmanned technique technique avoiding the use of personnel working in the excavated bore during installation.

4 General

Pipelines, manholes and inspection chambers are essentially engineering structures in which the combined performance of construction components, bedding, and fill or the surrounding ground constitute the basis for stability and safety in operation. The pipes, fittings and components for jointing supplied, together with the work carried out at site, are all important factors in achieving a structure with adequate performance.

5 Construction components and materials

5.1 General

Construction components and materials shall conform to national standards, transposing European Standards as available, or to European technical approvals, or, in the absence of these, the components and materials shall comply with the requirements of the specifier.

Any supplementary instructions of the manufacturer shall be observed.

5.2 Pipes and joints

Installation shall not commence before the following criteria have been agreed between the specifier and installer. These may be obtained from appropriate product standards or from the pipe manufacturer:

- internal pipe diameter;
- external pipe diameter;
- pipe length;
- tolerances on dimensions;
- safe jacking load or pulling force;
- type and performance of joints;
- longitudinal flexibility (acceptable bending radius or angular deflection).

5.3 Manholes and inspection chambers

Manholes and inspection chambers shall be in accordance with product standards or appropriate specifications.

5.4 Delivery, handling and transportation on site

Pipes, pipeline components and jointing accessories shall be inspected on delivery to ensure that they are appropriately marked and comply with the design requirements.

Any instructions from the manufacturer shall be adhered to.

Products shall be examined both on delivery and immediately prior to installation to ensure that they are free from damage.

5.5 Storage

Any instructions from the manufacturer and the requirements of the appropriate product standards shall be adhered to.

All materials should be stored in such a manner to keep them clean and to avoid contamination or degradation, for example elastomeric jointing components should be kept clean and be protected from sources of ozone (e.g. electrical equipment), sunlight and oil, where necessary.

Pipes shall be secured to prevent rolling. Excessive stacking heights should be avoided so that pipes in the lower part of the stacks are not overloaded. Stacks of pipes shall not be placed close to open trenches.

Pipes with protective coatings shall be stored where necessary, on supports which keep them clear of the ground to avoid damage to coatings and joints. All pipes should be stored on supports in very cold weather to avoid freezing to the ground.

6 Techniques

A schematic classification of trenchless techniques is given in Figure 1, representing techniques available at the time of publication of this European Standard.

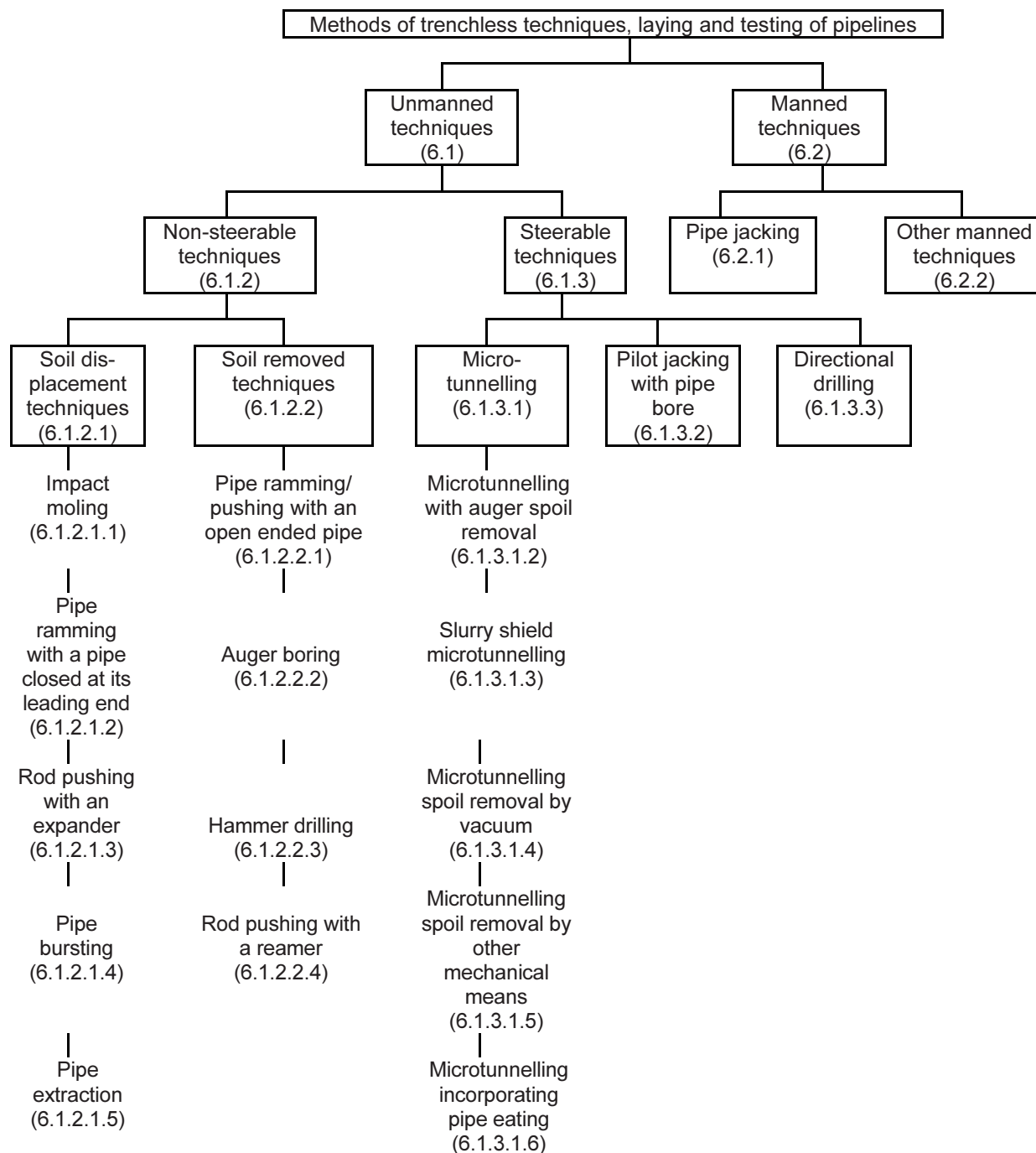

Figure 1: Trenchless techniques

6.1 Unmanned techniques

Pipes are installed with the aid of percussive, vibrating or steadily applied forces, through the ground, from an entry shaft or other access to an exit shaft or other reception point. The soil is displaced or removed from the face.

6.1.1 General

Systems may be non-steerable or steerable.

The choice of technique will depend on the following factors:

- accuracy required in line and level;
- proximity of other services;
- external diameter;
- length to be driven;
- ground conditions;
- groundwater conditions and
- minimum depth of cover.

6.1.2 Non-steerable techniques

Accuracy of alignment of a non-steerable technique is influenced by the properties of the ground (especially inclusions and stratification) and the driven length. Therefore these techniques are limited to the installation of pipelines which do not require precise alignment. Special precautions are required to avoid damage to other structures and underground services.

6.1.2.1 Soil displacement techniques

6.1.2.1.1 Impact moling

Impact moling uses a tool which comprises a percussive hammer within a casing, generally a cylinder with tapered nose or stepped head, which travels through the ground (see Figure 2). The hammer can be pneumatic or hydraulic. Its forward movement displaces the soil and relies on the frictional resistance of the ground. A pipe is pulled or pushed either immediately behind the impact moling tool or through an unsupported bore which may be formed in suitable ground.

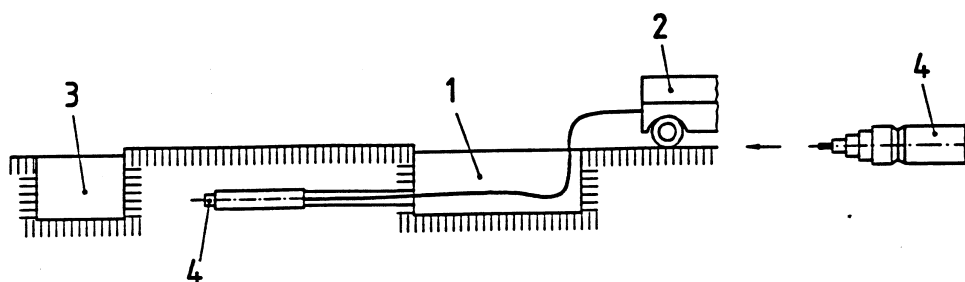

- 1 Entry shaft
- 2 Hydraulic pump/air compressor
- 3 Exit shaft
- 4 Percussive hammer

Figure 2: Example of impact moling

6.1.2.1.2 Pipe ramming with a pipe closed at its leading end

Pipe ramming with a pipe closed at its leading end is a technique of forming a bore by driving a steel casing with a closed end using a percussive hammer (see Figure 3). The ground is displaced by the closed end.

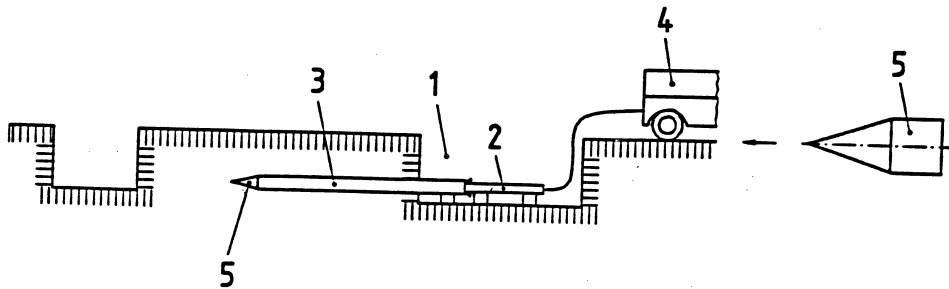

- 1 Entry shaft
- 2 Ram system
- 3 Pipe closed at its leading end
- 4 Hydraulic pump/air compressor
- 5 Closed leading end of pipe

Figure 3: Example of pipe ramming with a pipe closed at its leading end

6.1.2.1.3 Rod pushing with an expander

Ground is displaced by pushing a rigid pilot rod. The final pipeline is installed by pulling or pushing behind an expander (see Figure 4).

- 1 Entry shaft

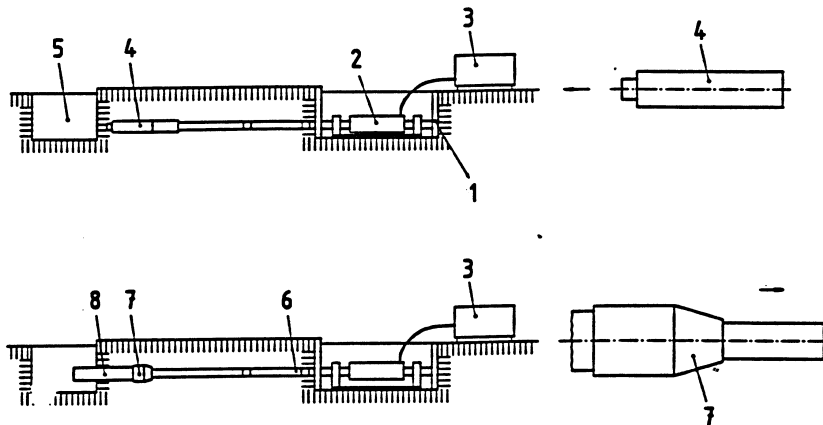

- 2 Ram system
- 3 Hydraulic pump
- 4 Pilot rod
- 5 Exit shaft
- 6 Rod
- 7 Expander
- 8 Pipe

Figure 4: Example of rod pushing with an expander

6.1.2.1.4 Pipe bursting

The original pipeline is burst and displaced together with the surrounding ground by an expanding device (see Figure 5). The expanding device can be a pneumatic or hydraulic hammer, a hydraulic expander or a fixed cone, pulled or pushed through the original pipeline, followed by the new pipeline of the same or

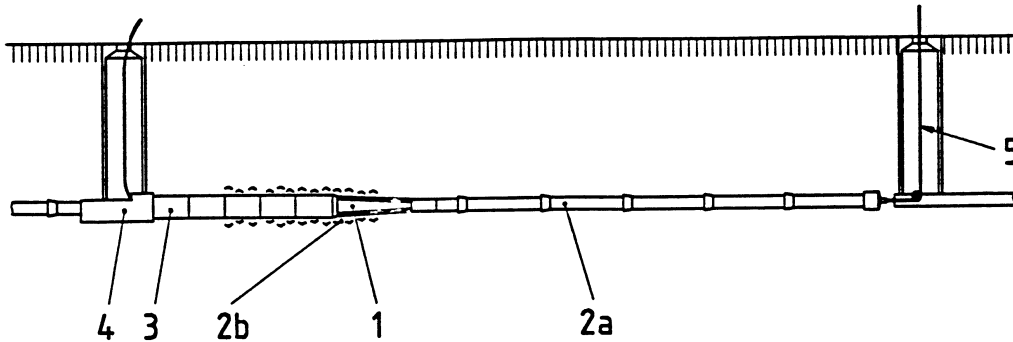

greater size.

- 1 Expander
- 2a Existing pipeline
- 2b Burst pipeline
- 3 New pipe
- 4 Hydraulic pump
- 5 Exit shaft

Figure 5: Example of pipe bursting

6.1.2.1.5 Pipe extraction

The original pipeline is extracted by pulling or pushing and simultaneously replaced by a new one (see Figure 6). When the diameter of the new pipe is significantly larger than the old, an expander is used.

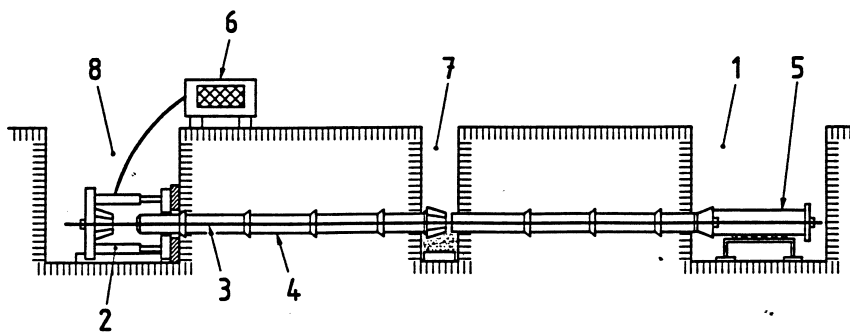

- 1 Entry shaft
- 2 Hydraulic pipe pulling device
- 3 Pulling rod
- 4 Existing pipe
- 5 New pipe
- 6 Hydraulic pump
- 7 Intermediate shaft
- 8 Exit shaft

Figure 6: Example of pipe extraction

6.1.2.2 Soil removal techniques

6.1.2.2.1 Pipe ramming/pushing with an open ended pipe

Pipe ramming with an open ended pipe is a technique of forming a bore by driving a steel casing with an open end using a percussive hammer or pushing device (see Figure 7). The spoil is removed by augering, jetting, compressed air or high pressure water.

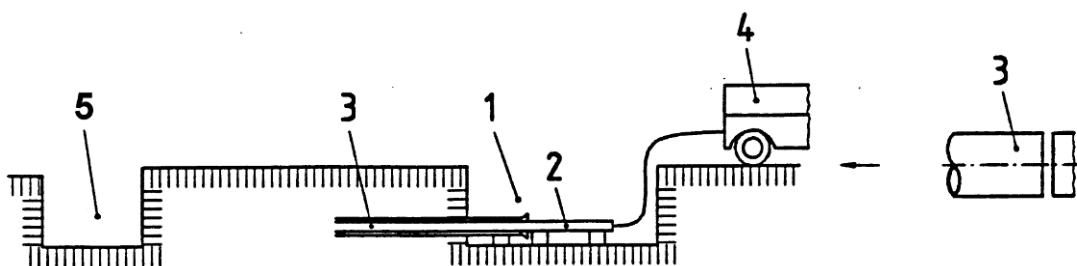

- 1 Entry shaft
- 2 Ram system
- 3 Driving pipe
- 4 Hydraulic pump/air compressor
- 5 Exit shaft

Figure 7: Example of pipe ramming/pushing with an open ended pipe

6.1.2.2.2 Auger boring

Soil is excavated by a rotating cutting head attached to an auger which continuously removes the spoil. The pipeline is pushed simultaneously with and independently from the auger (see Figure 8). The equipment can have limited steering capability.

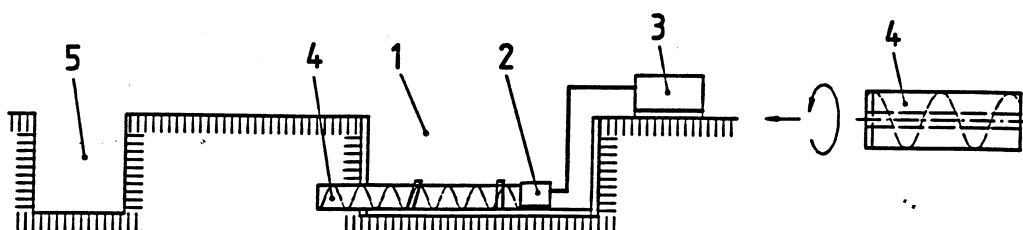

- 1 Entry shaft
- 2 Pushing/boring system
- 3 Hydraulic pump
- 4 Cutting head with auger
- 5 Exit shaft

Figure 8: Example of auger boring

6.1.2.2.3 Hammer drilling

Hammer drilling uses a percussive hammer mounted at the cutting head in the excavated bore with or without a sleeve (see Figure 9). The spoil is removed mechanically, by water or compressed air.

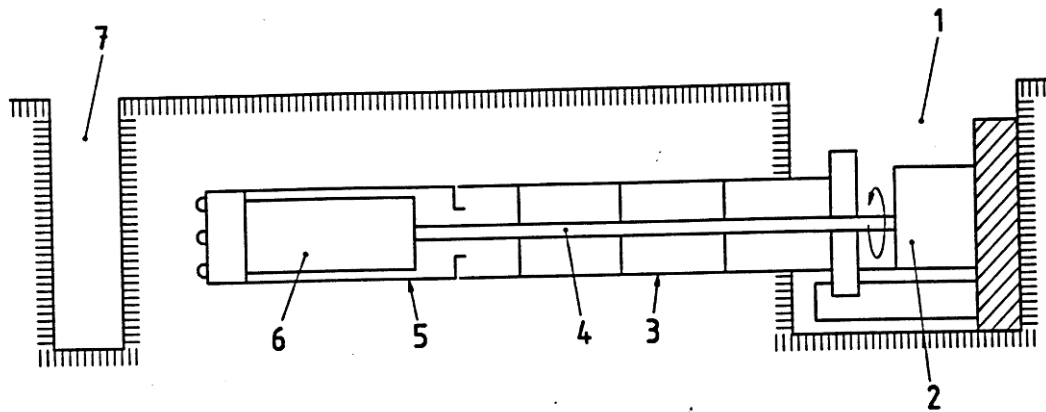

- 1 Entry shaft
- 2 Power unit
- 3 Pipe
- 4 Rod
- 5 Sleeve pipe
- 6 Hammer with cutting head
- 7 Exit shaft

Figure 9: Example of hammer drilling

6.1.2.2.4 Rod pushing with a reamer

Soil is displaced by pushing a rigid pilot rod. The new pipeline is installed by pulling it behind a rotating reamer.

6.1.3 Steerable techniques

6.1.3.1 Microtunnelling

6.1.3.1.1 General

Microtunnelling is a steerable single pass remote control pipe jacking technique generally for pipelines less than one metre internal diameter which is remotely controlled by an operator from outside the tunnel. The pipeline is installed directly behind the microtunnelling machine.

NOTE: Originally microtunnelling was restricted to diameters up to DN 1000: further technical development has allowed greater diameters to be jacked.

6.1.3.1.2 Microtunnelling with auger spoil removal

An auger is used for removal of spoil (see Figure 10).

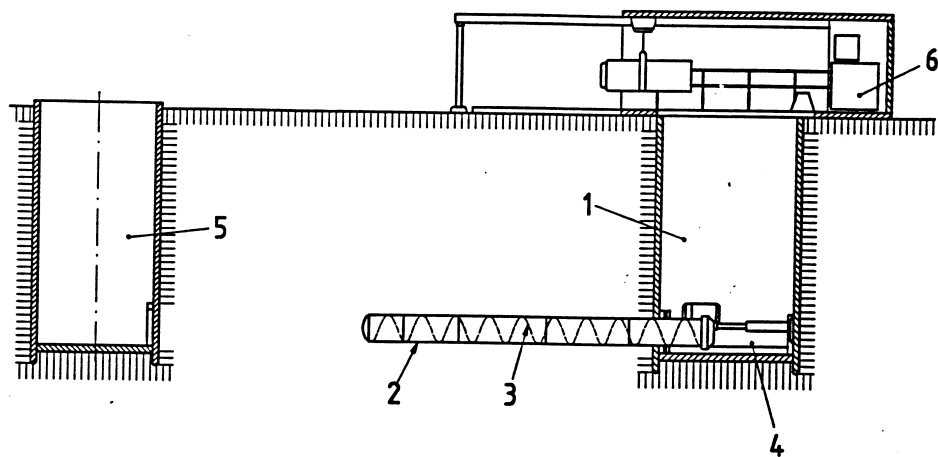

- 1 Entry shaft
- 2 Jacking pipe
- 3 Auger
- 4 Jacking system
- 5 Exit shaft
- 6 Power unit

Figure 10: Example of microtunnelling with auger spoil removal

6.1.3.1.3 Slurry shield microtunnelling

A slurry system is used for removal of spoil (see Figure 11).

- 1 Entry shaft

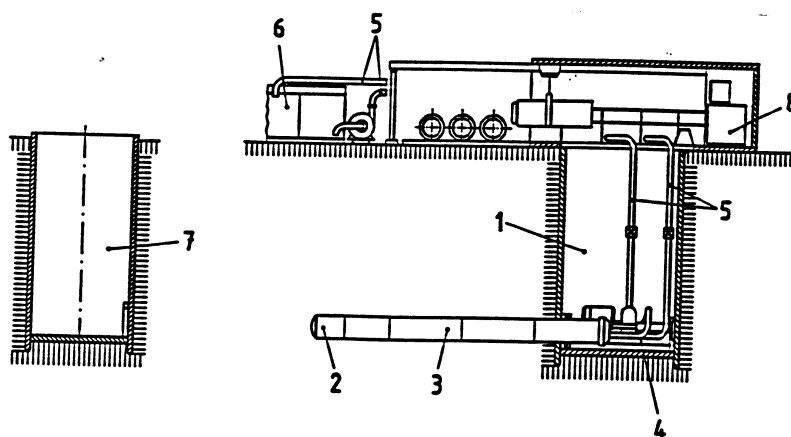

- 2 Cutting head
- 3 Jacking pipe
- 4 Jacking device
- 5 Slurry pipeline
- 6 Slurry tank
- 7 Exit shaft
- 8 Aggregates

Figure 11: Example of slurry shield microtunnelling

6.1.3.1.4 Microtunnelling spoil removal by vacuum

A vacuum system is used for removal of spoil.

6.1.3.1.5 Microtunnelling spoil removal by other mechanical means

Mechanical systems other than those above are used for removal of spoil.

6.1.3.1.6 Microtunnelling incorporating pipe eating

An existing pipe is excavated together with surrounding ground. The microtunnelling machine incorporates crushing or cutting capability. Spoil can be removed by an auger or slurry system.

The existing pipeline may be filled with a suitable material to improve steering performance or retain slurry. Alternatively, some systems employ a proboscis device to seal the existing pipe in front of the shield.

6.1.3.2 Pilot jacking with pipe bore

Pilot jacking with pipe bore is a multi phase method (see Figure 12). In the first phase a steered rigid pilot pipe is accurately installed. In subsequent phases the pilot bore is enlarged and the pipes installed by soil displacement or soil removal methods.

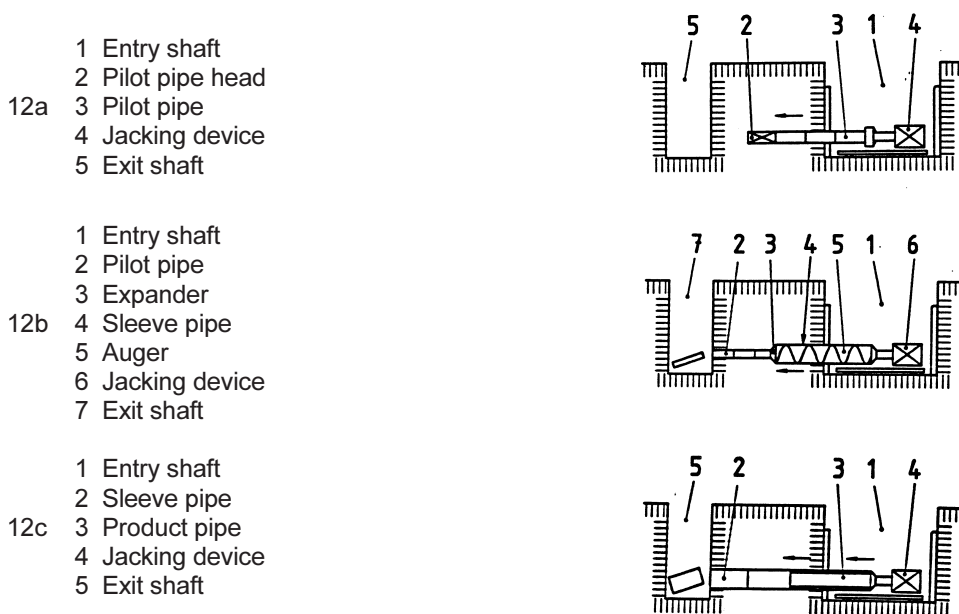

Figure 12: Example of pilot jacking with pipe bore

6.1.3.3 Directional drilling

A steerable system for the installation of pipelines using a drilling rig (see Figure 13). A pilot bore is drilled using a steerable drilling head pushed by flexible rods. The bore is then enlarged by reamers up to the diameter required for the pipeline and then the pipe or pipes are pulled/pushed into place.

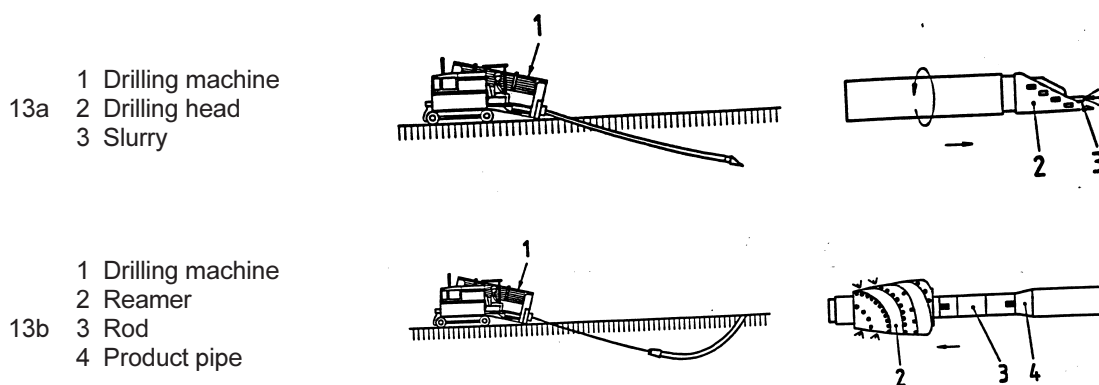

Figure 13: Example of directional drilling

6.2 Manned techniques

6.2.1 Pipe jacking

With the aid of steadily applied forces, pipes are installed through the ground, from an entry shaft or other access point, into an exit shaft or other reception point. The soil is removed from the face either manually, mechanically or using a slurry system.

Pipe jacking systems are generally steerable and allow installation in a straight line or through a slight curve.

These techniques include the use of

- open shields with or without compressed air, with or without lowering of groundwater;
- closed shields with or without compressed air or other face support systems, e.g. earth or slurry pressure balance.

6.2.2 Other manned techniques

Pipelines can be constructed by other tunnelling techniques, e.g. in situ by lining the excavated tunnel, or prefabricated pipes can be installed in the tunnel from an access shaft. Requirements for these methods are not detailed in this European Standard.

7 Requirements

7.1 Protection of existing structures

Where necessary appropriate safety measures for other supply pipelines, drains and sewers, other services, constructions or surfaces shall be observed to protect these against detrimental effects.

7.2 Special requirements

Special requirements for the installation of pipelines by trenchless techniques can apply under or above railways, roads, airport areas, waterways, buildings and in water abstraction areas.

7.3 Safeguarding design assumptions

The strength of the pipeline, including the effect of acceptable angular deviation of pipe joints (e.g. with regard to tightness, steering specifications, curve driving) shall be determined, decided or specified before construction work is undertaken taking into account design loads and geotechnical loads.

In the execution of the work it should be ensured that the assumptions made in the design are safeguarded or adapted to changed conditions.

7.4 Information about ground conditions

To assist in selection of the appropriate installation techniques and thereby to ensure satisfactory installation, some or all of the following ground parameters should be assessed.

For loose soil

- geological log;
- grain shape, distribution and abrasivity;
- consolidation properties;
- maximum and minimum groundwater level;
- undrained and effective shear strength;
- sensitivity to changed conditions, e.g. moisture, capability for swelling;
- deformation characteristics (modulus of elasticity);
- earth pressure coefficient;
- permeability coefficient;
- degree of contamination of the soil by solids, gases and liquids;
- conditions for waste disposal;
- information on possible aggressive effect of soil and groundwater;
- organic soils;
- density.

For rock and other self supporting material:

- geological log and description of the condition;
- fault line and spatial orientation;
- details on hardness and removal ability;
- single axis compression strengths;
- amount of water, groundwater level maximum and minimum;
- degree of contamination of the rock and ground by solids, gases and liquids;
- conditions for waste disposal;
- information on possible aggressive effect of soil and groundwater;
- density;
- abrasivity.

If the initial soil or site investigation indicates a more complex situation, e.g. varying or inclined strata, or swell pressure, supplementary surveys should be carried out.

7.5 Data collection during installation

The following data shall be recorded, if possible automatically, during installation and archived.

For microtunnelling:

- line and level;
- maximum jacking forces of the main and, if used, intermediate thrust stations;
- jacking speed/distance;
- quantity of lubricant and, if possible, of excavated soil;
- rolling;
- steering correction.

Maximum interval of recordings should be 0,2 m.

For manned techniques:

- maximum jacking forces of the main and, if used, intermediate thrust stations;
- line and level;
- jacking speed/distance;
- quantity of lubricant and, if possible, of excavated soil;
- rolling.

Maximum interval of recordings should be once per pipe.

For directional drilling:

- line, level and length;
- quantity and characteristics of drilling fluid;
- maximum pulling forces.

Maximum interval of recordings should be once per drilling rod.

7.6 Stability during construction

7.6.1 Launch and reception shafts

Shafts shall be designed and constructed to resist, with an appropriate safety factor, all applicable static and dynamic loads including the maximum driving force that may be applied.

7.6.2 Pipeline

Method and equipment should be selected to avoid ground loss and minimize settlement and heave.

The risk of loss of ground or heave and the loss of lubricants should be continually assessed and the method modified if necessary.

7.6.3 Guidance system

When installation is guided by laser or other optical system this shall be isolated from movements created by the driving forces.

7.7 Overcut

The overcut shall be agreed, taking into account requirements for settlement and deviation, and kept as small as possible.

7.8 Overbreak

Overbreak depends on ground conditions, method and operation used for driving. It is important to keep the overbreak as small as possible.

7.9 Settlement and heave

Settlement and heave of the ground influenced by the installation should be monitored during installation and shall not exceed the values given by the specification.

When settlement of other services, adjacent structures or of the surface has to be minimized, the void between the pipe and the ground should be filled with suitable material. The filling material and its method of insertion shall be specified.

7.10 Deviation in line and level

The maximum limit of deviation from line and level shall be specified in the design taking into account:

- requirements of function and maintenance;
- gradient of drain or sewer;
- possibility of installation methods to be used;
- existing structures, other services and obstructions;
- ground conditions.

8 Inspection and testing of pipelines after installation

After completion of the installation, inspection and leaktightness tests shall be carried out in accordance with 8.1 and 8.2.

The results of inspection and test shall be recorded and archived.

8.1 Visual inspection

Visual inspection includes:

- line and level;
- joints;
- damage;
- deformation;
- connections;
- linings and coatings.

8.2 Leaktightness

Leaktightness of pipeline including connections, manholes and inspection chambers shall be tested according to clause 9 or clause 10 as appropriate.

In the case of pipelines within ducts it may not be necessary to test the leaktightness of the ducts.

9 Procedures and requirements for testing gravity pipelines

9.1 General

Testing for leaktightness of pipelines, manholes and inspection chambers shall be conducted either with air (method “L”) or water (method “W”) as given in Figures 14 and 15. Separate testing of pipes and fittings, manholes and inspection chambers, e.g. pipes with air and manholes with water, may be undertaken. In the case of method “L”, the number of corrections and re-tests following failure is unrestricted. In the event of a single or continued air test failure recourse to a water test is allowed and the result of the water test alone shall be decisive.

If groundwater level is present above the crown of the pipeline during testing, an infiltration test may be applied with individual specification.

For acceptance the line shall be tested after installation; choice of testing by air or water may be given by the specifier.

9.2 Testing with air (method “L”)

The testing times for pipelines excluding manholes and inspection chambers are given in Table 1 in relation to pipe size and testing methods (LA; LB; LC; LD). The choice of testing method should be given by the specifier. Suitable airtight plugs shall be used in order to avoid errors arising from the test equipment. Special care is required during testing of large diameter pipelines for safety reasons.

Air testing of manholes and inspection chambers is difficult to implement in practice.

NOTE 1: Until there is sufficient experience on air tests of manholes and inspection chambers, a testing time of half that for an equivalent diameter pipeline may be used.

An initial pressure approximately 10 % in excess of the required test pressure, p_o , shall first be held for approximately 5 min. The pressure shall then be adjusted to the test pressure shown in Table 1 related to testing method LA, LB, LC or LD. If the pressure drop measured after the testing time is less than Δp given in Table 1 then the pipeline complies.

NOTE 2: The test requirements for subatmospheric air pressure testing are not given in this European Standard as there is currently insufficient experience with this method.

The equipment used for measuring the pressure drop shall allow a measurement with an accuracy of 10 % of Δp . The accuracy of measurement of time shall be 5 s.

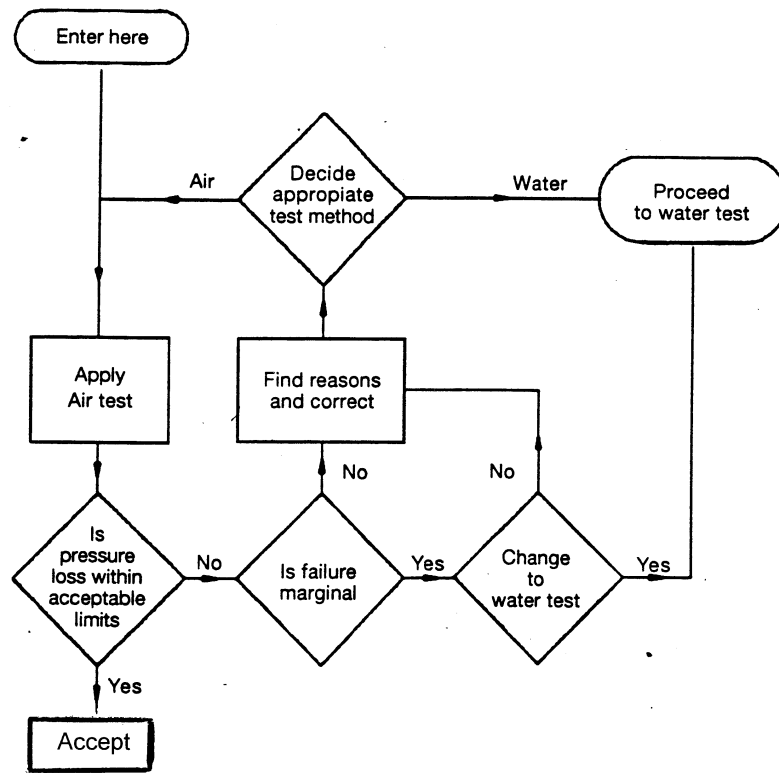

Figure 14: Flow diagram method "L"

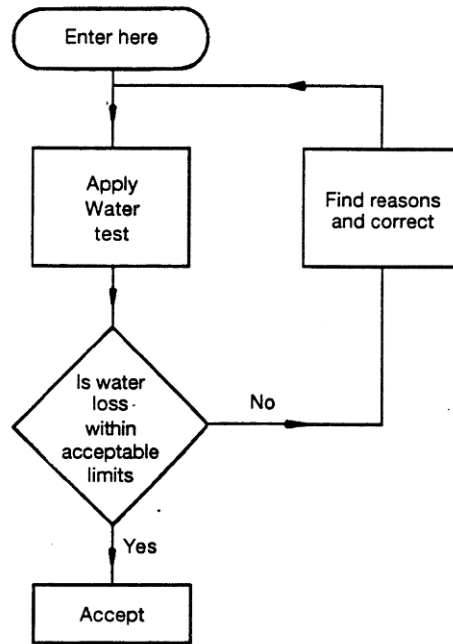

Figure 15: Flow diagram method "W"

Table 1: Test pressure, pressure drop and testing times for testing with air

Testing method	$p_o^{*)}$		Testing time (min)						
	Δp mbar (kPa)		DN 100	DN 200	DN 300	DN 400	DN 600	DN 800	DN 1000
LA	10 (1)	2,5 (0,25)	5	5	7	10	14	19	24
LB	50 (5)	10 (1)	4	4	6	7	11	15	19
LC	100 (10)	15 (1,5)	3	3	4	5	8	11	14
LD	200 (20)	15 (1,5)	1,5	1,5	2	2,5	4	5	7
K_p values**)			0,058	0,058	0,040	0,030	0,020	0,015	0,012

*) Pressure above atmospheric pressure.

$$**) \quad t = \frac{1}{K_p} \ln \frac{p_o}{p - \Delta p}$$

$$K_p = \frac{12}{DN} \quad \text{with maximum } 0,058.$$

With t rounded to the nearest 0,5 min when $t \leq 5$ min, to the nearest min when $t > 5$ min.

$\ln = \log_e$

9.3 Testing with water (method "W")

9.3.1 Test pressure

The test pressure is the pressure equivalent to or resulting from filling the test section up to the ground level of the downstream or upstream manhole, as appropriate, with a maximum pressure of 50 kPa and a minimum pressure of 10 kPa measured at the top of the pipe.

Higher test pressures may be specified for pipelines which are designed to operate under permanent or temporary surcharge (see prEN 805:1999).

9.3.2 Conditioning time

After the pipelines and/or manholes are filled and the required test pressure applied, conditioning may be necessary.

NOTE: Usually 1 hour is sufficient. Under certain circumstances a longer period may be needed.

9.3.3 Testing time

The testing time shall be (30 ± 1) min.

9.3.4 Test requirements

Pressure shall be maintained within 1 kPa of the test pressure defined in 9.3.1 by topping up with water.

The total amount of water added during the test to achieve this requirement shall be measured and recorded with the head of water at the required test pressure.

The test requirement is satisfied if the amount of water added is not greater than

- 0,15 l/m² during 30 min for pipelines;
- 0,20 l/m² during 30 min for pipelines and manholes;
- 0,40 l/m² during 30 min for manholes and inspection chambers.

NOTE: m² refers to the wetted internal surface.

9.4 Testing of each individual joint

Unless otherwise specified, testing of each individual joint instead of testing the whole pipeline can be accepted.

For individual pipe joints to be tested the surface area for test "W" is taken as that represented by 1 m length of pipe, if not otherwise specified. Test requirements shall be as given in 9.3.4 with a test pressure of 50 kPa at the top of the pipe.

The conditions for test "L" shall follow the principles given in 9.2 and be specified individually.

10 Testing of pressure pipelines

Pressure pipelines shall be tested as specified in prEN 805:1999.

11 Qualifications

The following factors concerning qualifications are to be taken into account:

- suitably trained and experienced personnel are employed for the supervision and the execution of the construction project;
- contractors appointed by the employer possess the qualifications necessary for the execution of the work;
- employers satisfy themselves that the necessary qualifications are held by the contractors.

See annex A.

Annex A (informative)

Abstract from Council Directive of 17 September 1990 on the procurement procedures of entities operating in the water, energy, transport and telecommunication sectors.

Title IV

Qualification, selection and award

Article 24

1. Contracting entities which so wish may establish and operate a system of qualification of suppliers or contractors.
2. The system, which may involve different qualification stages, shall operate on the basis of objective rules and criteria to be established by the contracting entity. The contracting entity shall use European Standards as a reference where they are appropriate. The rules and criteria may be updated as required.
3. The rules and criteria for qualification shall be made available on request to interested suppliers or contractors. The updating of these criteria and rules shall be communicated to the interested suppliers and contractors. Where a contracting entity considers that the qualification or certification system of certain third entities or bodies meet its requirements, it shall communicate to interested suppliers and contractors the names of such third entities or bodies.
4. Contracting entities shall inform applicants of their decision as to qualification within a reasonable period. If the decision will take longer than six months from the presentation of an application, the contracting entity shall inform the applicant, within two months of the application, of the reasons justifying a longer period and of the date by which its application will be accepted or refused.
5. In reaching their decision as to qualification or when the criteria and rules are being updated, contracting entities may not:
 - impose conditions of an administrative, technical or financial nature on some suppliers or contractors that are not imposed on others,
 - require tests or proof that duplicate objective evidence already available.

BSI — British Standards Institution

BSI is the independent national body responsible for preparing British Standards. It presents the UK view on standards in Europe and at the international level. It is incorporated by Royal Charter.

Revisions

British Standards are updated by amendment or revision. Users of British Standards should make sure that they possess the latest amendments or editions.

It is the constant aim of BSI to improve the quality of our products and services. We would be grateful if anyone finding an inaccuracy or ambiguity while using this British Standard would inform the Secretary of the technical committee responsible, the identity of which can be found on the inside front cover. Tel: 020 8996 9000. Fax: 020 8996 7400.

BSI offers members an individual updating service called PLUS which ensures that subscribers automatically receive the latest editions of standards.

Buying standards

Orders for all BSI, international and foreign standards publications should be addressed to Customer Services. Tel: 020 8996 9001. Fax: 020 8996 7001.

In response to orders for international standards, it is BSI policy to supply the BSI implementation of those that have been published as British Standards, unless otherwise requested.

Information on standards

BSI provides a wide range of information on national, European and international standards through its Library and its Technical Help to Exporters Service. Various BSI electronic information services are also available which give details on all its products and services. Contact the Information Centre. Tel: 020 8996 7111. Fax: 020 8996 7048.

Subscribing members of BSI are kept up to date with standards developments and receive substantial discounts on the purchase price of standards. For details of these and other benefits contact Membership Administration. Tel: 020 8996 7002. Fax: 020 8996 7001.

Copyright

Copyright subsists in all BSI publications. BSI also holds the copyright, in the UK, of the publications of the international standardization bodies. Except as permitted under the Copyright, Designs and Patents Act 1988 no extract may be reproduced, stored in a retrieval system or transmitted in any form or by any means – electronic, photocopying, recording or otherwise – without prior written permission from BSI.

This does not preclude the free use, in the course of implementing the standard, of necessary details such as symbols, and size, type or grade designations. If these details are to be used for any other purpose than implementation then the prior written permission of BSI must be obtained.

If permission is granted, the terms may include royalty payments or a licensing agreement. Details and advice can be obtained from the Copyright Manager. Tel: 020 8996 7070.