

Mechanical seals — Principal dimensions, designation and material codes

The European Standard EN 12756:2000 has the status of a
British Standard

ICS 21.140

National foreword

This British Standard is the official English language version of EN 12756:2000.

The UK participation in its preparation was entrusted by Technical Committee MCE/6, Pumps and pump testing, to Subcommittee MCE/6/2, Dimensions and technical specifications, which has the responsibility to:

- aid enquirers to understand the text;
- present to the responsible European committee any enquiries on the interpretation, or proposals for change, and keep the UK interests informed;
- monitor related international and European developments and promulgate them in the UK.

A list of organizations represented on this subcommittee can be obtained on request to its secretary.

Cross-references

The British Standards which implement international or European publications referred to in this document may be found in the BSI Standards Catalogue under the section entitled “International Standards Correspondence Index”, or by using the “Find” facility of the BSI Standards Electronic Catalogue.

A British Standard does not purport to include all the necessary provisions of a contract. Users of British Standards are responsible for their correct application.

Compliance with a British Standard does not of itself confer immunity from legal obligations.

Summary of pages

This document comprises a front cover, an inside front cover, the EN title page, pages 2 to 11 and a back cover.

The BSI copyright notice displayed in this document indicates when the document was last issued.

This British Standard, having been prepared under the direction of the Engineering Sector Committee, was published under the authority of the Standards Committee and comes into effect on 15 February 2001

© BSI 02-2001

Amendments issued since publication

Amd. No.	Date	Comments

ICS 21.140

English version

Mechanical seals - Principal dimensions, designation and material codes

Garnitures mécaniques d'étanchéité - Dimensions principales, désignation et codes matériaux

Gleitringdichtungen - Hauptmaße, Bezeichnung und Werkstoffschlüssel

This European Standard was approved by CEN on 8 November 1999.

CEN members are bound to comply with the CEN/CENELEC Internal Regulations which stipulate the conditions for giving this European Standard the status of a national standard without any alteration. Up-to-date lists and bibliographical references concerning such national standards may be obtained on application to the Management Centre or to any CEN member.

This European Standard exists in three official versions (English, French, German). A version in any other language made by translation under the responsibility of a CEN member into its own language and notified to the Management Centre has the same status as the official versions.

CEN members are the national standards bodies of Austria, Belgium, Czech Republic, Denmark, Finland, France, Germany, Greece, Iceland, Ireland, Italy, Luxembourg, Netherlands, Norway, Portugal, Spain, Sweden, Switzerland and United Kingdom.



EUROPEAN COMMITTEE FOR STANDARDIZATION
COMITÉ EUROPÉEN DE NORMALISATION
EUROPÄISCHES KOMITEE FÜR NORMUNG

Management Centre: rue de Stassart, 36 B-1050 Brussels

Contents

	Page
Foreword.....	3
1 Scope	4
2 Normative references	4
3 Dimensions	5
4 Standard designation	9
5 Material key	11

Foreword

This European Standard has been prepared by Technical Committee CEN/TC 197 "Pumps", the secretariat of which is held by AFNOR.

This European Standard shall be given the status of a national standard, either by publication of an identical text or by endorsement, at the latest by June 2001, and conflicting national standards shall be withdrawn at the latest by June 2001.

According to the CEN/CENELEC Internal Regulations, the national standards organizations of the following countries are bound to implement this European Standard: Austria, Belgium, Czech Republic, Denmark, Finland, France, Germany, Greece, Iceland, Ireland, Italy, Luxembourg, Netherlands, Norway, Portugal, Spain, Sweden, Switzerland and the United Kingdom.

1 Scope

This European Standard defines the principal dimensions for the internal installation of single and multiple mechanical seals with (rotating) spring units into the pump sealing cavity according to ISO 3069 as minimum cavity dimensions as typical for centrifugal pumps in accordance with EN 22858 and EN 733. It also gives the seal designations and material codes to be used.

2 Normative references

This European Standard incorporates by dated or undated reference, provisions from other publications. These normative references are cited at the appropriate places in the text and the publications are listed hereafter. For dated references, subsequent amendments to or revisions of any of these publications apply to this European Standard only when incorporated in it by amendment or revision. For undated references the latest edition of the publication referred to applies.

EN 733, *End-suction centrifugal pumps, rating 10 bar with bearing bracket — Nominal duty point, main dimensions, designation system*

EN 22858, *End suction centrifugal pumps (rating 16 bar) — Designation, nominal duty point and dimensions (ISO 2858:1975)*

ISO 1382, *Rubber — Vocabulary Trilingual edition*

ISO 1629, *Rubbers and latices — Classification, symbols*

ISO 2768-1, *General tolerances — Part 1: Tolerances for linear and angular dimensions without individual tolerance indications*

ISO 3069, *End suction centrifugal pumps — Dimensions of cavities for mechanical seals and for softpacking*

ISO 5199, *Technical specifications for centrifugal pumps — Class II*

ISO 9905, *Technical specifications for centrifugal pumps — Class I*

ISO 9908, *Technical specifications for centrifugal pumps — Class III*

3 Dimensions

The mechanical seals (abbreviation: GLRD¹⁾) and cavities need not correspond to the illustrations, however, the dimensions given shall be complied with. The figures show O-rings as the flexible elements but other shapes of seals may also be used.

General tolerances: ISO 2768–m

3.1 Example for a single mechanical seal²⁾ with rotating spring unit, version N and K³⁾

NOTE Alternative arrangements using the same dimensions can be possible.

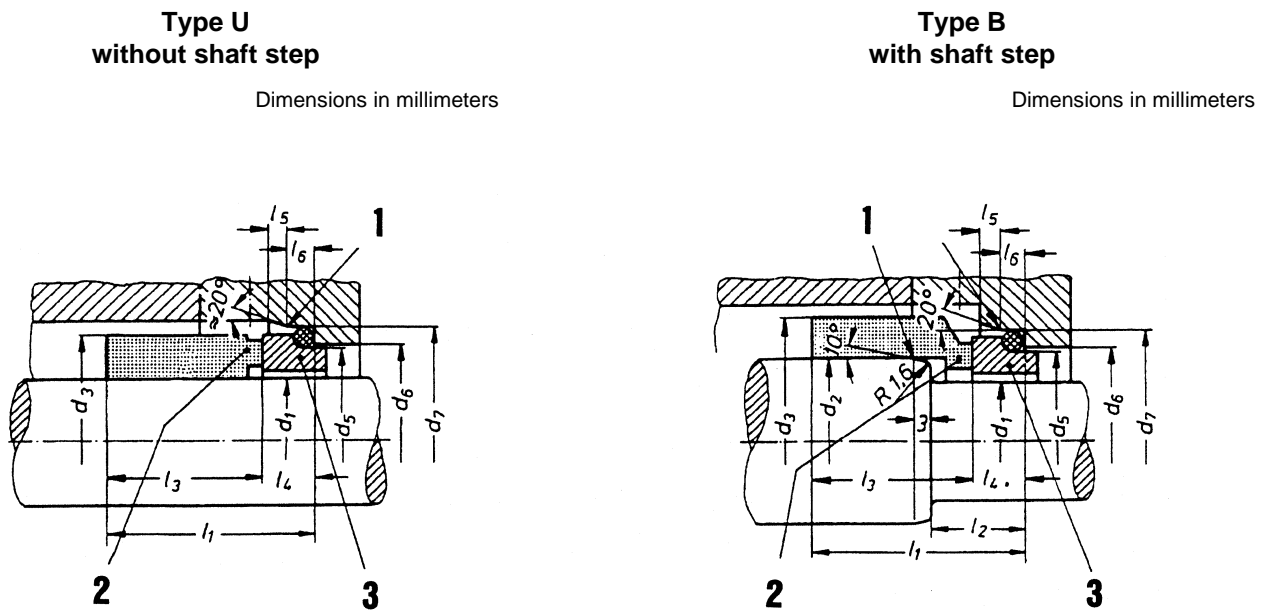

Key

- 1 rounded
- 2 spring loaded lead face
- 3 seat

Figure 1 — Examples for single mechanical seals

¹⁾ based on the German terminology

²⁾ for abbreviations concerning arrangements of shaft seals refer to ISO 5199

³⁾ N = Normal, K = Short

3.2 Retention of the seat

3.2.1 Against rotation

The design is at the descretion of the manufacturer or as agreed.

using a radial pin

Dimensions in millimeters

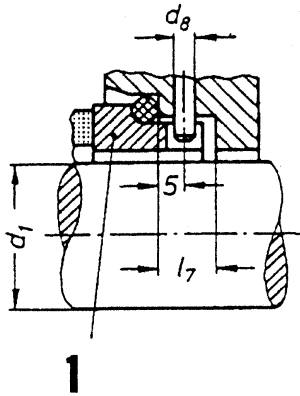

using an axial pin

Dimensions in millimeters

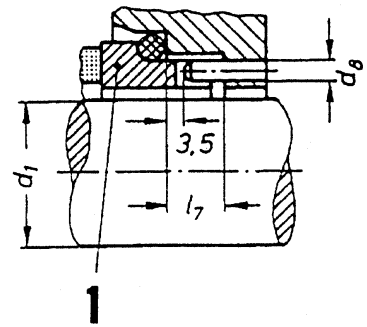

Key

1 seat

Figure 2 — Retention of the seat against rotation

These options are valid for both types U and B.

3.2.2 Against axial movement using a securing ring and stationary seat housing (only valid for mechanical seals on the product side with multiple arrangements)

Example of Type U

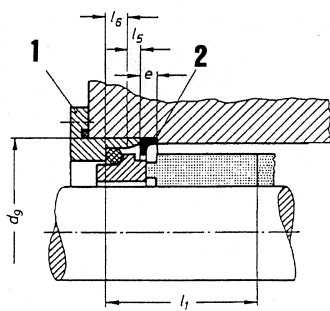

Example of Type B

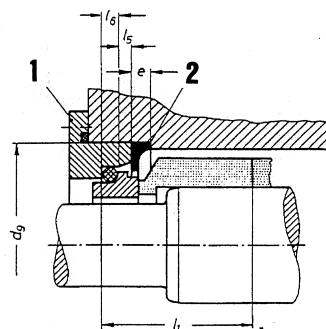

Key

1 Seat housing
2 Securing ring

Figure 3 — Retention of the seat against axial movement

The dimension e and d_9 refer to the seat housing. The manufacturer of the mechanical seal has to deliver the securing ring on demand.

3.3 Dimensions for versions N and K

Table 1 — Dimensions for versions N and K

Dimensions in millimeters

d_1		d_2	$d_3^{1)}$		d_5	d_6	d_7	d_8	d_9		e	$l_1^{2)}$				l_2	l_3	l_5	l_6	l_7	
Nominal diameter		Type B h6	Maximum dimensions		h8	H11	H8		Type U	Type B		Version N		Version K		$\pm 0,5$	l_4			$+0,5$ 0	
Type U h6	Type B		Type U	Type B					Type U	Type B		Type U	Type B	Type U	Type B						Type U
10		14	20	24		17	21		26	30											
12		16	22	26		19	23		28	32											
14		18	24	32		21	25		30	38	40	50	32,5	40	18		1,5	4	8,5		
16		20	26	34		23	27		32	40		55	35	42,5							
18		22	32	36		27	33		38	42											
20		24	34	38		29	35		40	43	45	60	37,5	45							
22		26	36	40		31	37		42	46											
24		28	38	42		33	39	3	43	48	4										
25		30	39	44		34	40		46	50											
28		33	42	47		37	43		48	53	50				20		2	5			
30		35	44	49		39	45		50	60											
32		38	46	54		42	48		53	62											
33		38	47	54		42	48		53	62											
35		40	49	56		44	50		60	65	55										
38		43	54	59	3)	49	56		62	67											
40		45	56	61		51	58		65	70		75	45	52,5	23					9	
43		48	59	64		54	61		67	72											
45		50	61	66		56	63		70	75											
48		53	64	69		59	66		72	77	60										
50		55	66	71		62	70		75	86											
53		58	69	78		65	73		77	88		85	47,5	57,5						6	
55		60	71	80		67	75		86	91											
58		63	78	83		70	78		88	93	70				25						
60		65	80	85		72	80		91	96											
63		68	83	88		75	83	4	93	98			52,5	62,5						2,5	
65		70	85	90		77	85		96	103		95									
68		-	88	-		81	90		98	-											
70		75	90	99		83	92		103	108	80										
75		80	99	104		88	97		108	120											
80		85	104	109		95	105		120	125											
85		90	109	114		100	110		125	130		105			28					7	
90		95	114	119		105	115		130	135	90									3	
95		100	119	124		110	120		135	140											
100		105	124	129		115	125		140	145											

1) In order to provide a safe clearance between the mechanical seal and the seal housing, the dimensions d_3 are recommended as the maximum dimensions.

2) The manufacturer of the mechanical seal may supply a shorter seal than that which corresponds to dimension l_1 . In this case, the difference in lengths should be compensated by use of a spacer, which should be supplied by the seal manufacturer. For materials see Position 5 of material key (see clause 5).

3) Those dimensions are not defined. They may vary, depending on the manufacturer of the mechanical seal and should therefore be obtained from the relevant suppliers literature.

3.4 Surface condition

Surface conditions shall comply to the values given in Table 2.

Table 2 — Surface condition

Secondary seal material	$\sqrt{x} =$	$\sqrt{z} =$
Elastomers ¹⁾	Ra 2,5	Ra 0,8
Non-elastomers or optional use of elastomers and non-elastomers	Ra 1,6	Ra 0,20

1) For explanation of elastomers refer to ISO 1382; symbols for rubbers and latices, refer to ISO 1629.

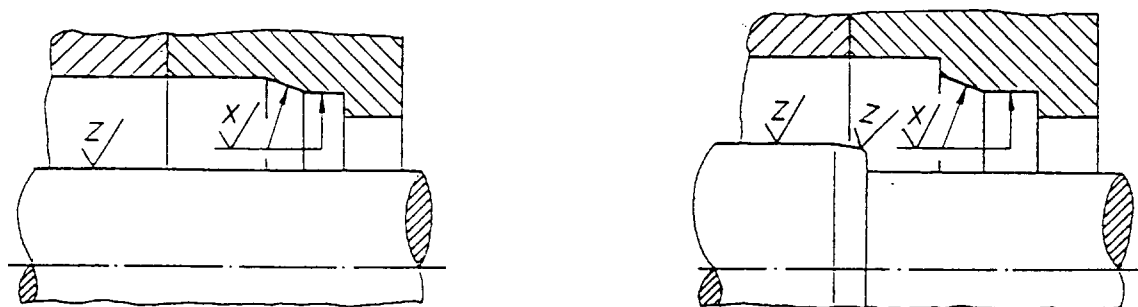

Figure 4 — Surface location

4 Standard designation

This section sets out a coding system for use in designating single and multiple seals by seal type, by nominal dimension, by orientation, and by the classes of materials used. The system is intended to be typical of those in current use and will help in the transfer of information between suppliers and users. It is not intended to fully and unambiguously identify facets of a seal assembly. It is intended to help to identify and group seals for recording purposes and for subsequent analysis.

NOTE It is not a requirement of this European Standard that seals are marked with a designation derived from this system.

4.1 Schematic representation of a designation for single mechanical seals

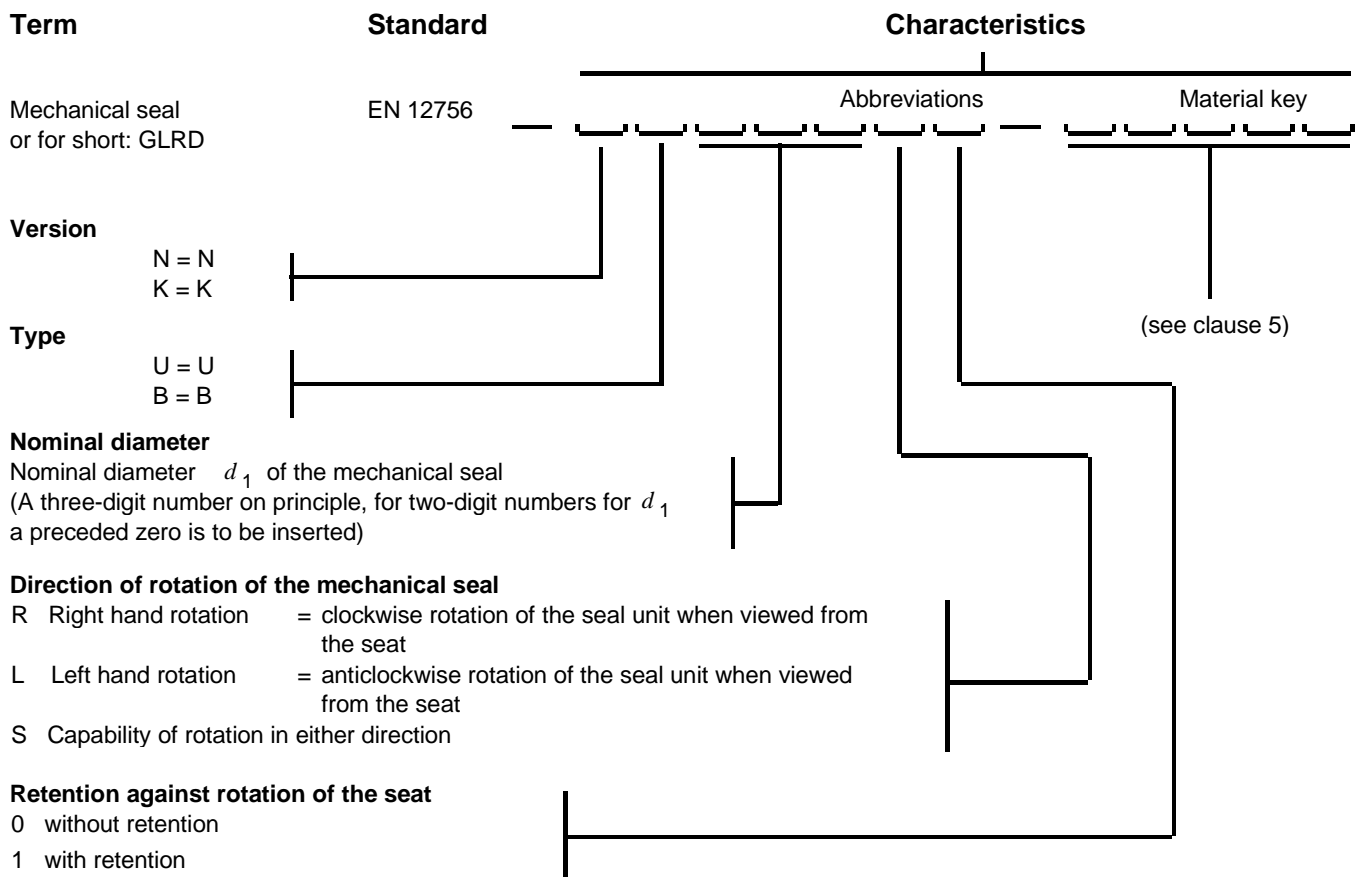

4.2 Example of designation for a single mechanical seal

Designation of a single mechanical seal of normal design (N) in form U with nominal diameter $d_1 = 43$ mm (043), right hand rotation (R), with securing of the atmospheric side seat against rotation (1), material of the seal face Chromium cast steel S, material of the seat Carbon, resin-impregnated B, material of flexible elements Fluorocarbon rubber V, material of the spring CrNiMo steel G and material of other components CrNiMo steel G:

Mechanical seal EN 12756—NU043R1—SBVGG

or for short: GLRD EN 12756—NU043R1—SBVGG

4.3 Schematic representation of designation for multiple mechanical seals (D1 Back-to-back arrangement)⁴⁾

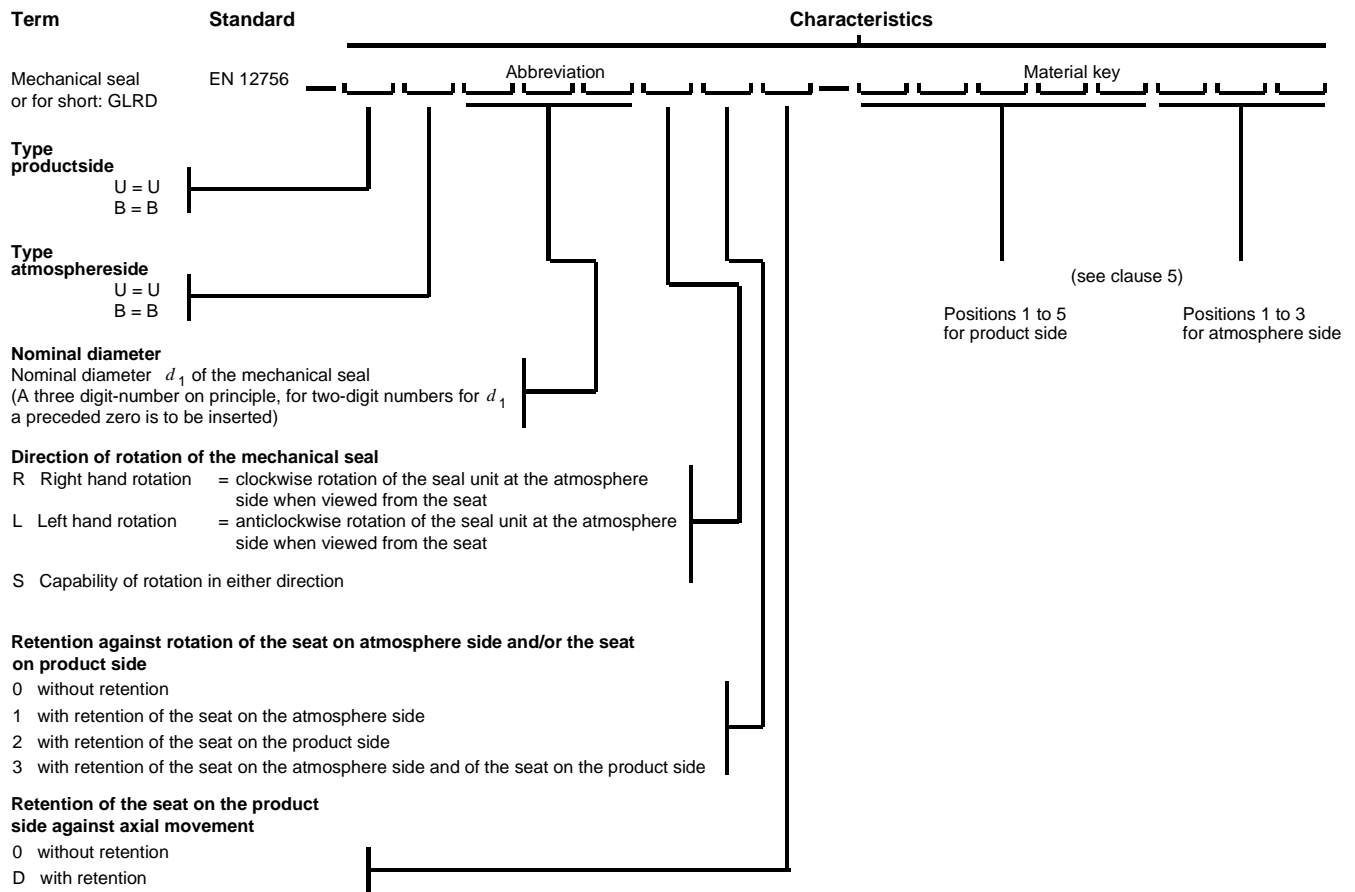

4.4 Example of designation for a multiple mechanical seal (D1)

Designation of a multiple mechanical seal (D1) type UU (UU) with nominal diameter $d_1 = 43$ mm (043), capability of rotation in either direction (S), with retention against rotation of the seat on atmosphere side (1), with retention against axial movement of the seat on the product side (D) and with the material key in accordance with clause 5 (VBVGGSBV):

Mechanical seal EN 12756—UU043S1D—VBVGGSBV

or for short: GLRD EN 12756—UU043S1D—VBVGGSBV

NOTE Multiple mechanical seals (D1 Back-to-back arrangement) consist of single mechanical seals, version K. For multiple mechanical seals (D1) with shorter length the total length is not standardized.

⁴⁾ see ISO 9905 and ISO 9908

5 Material key

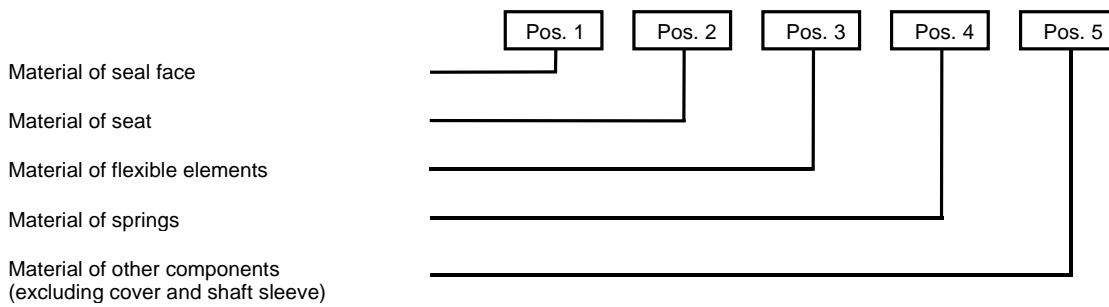

Table 3 — Explanation of symbols for material versions

Position 1/Position 2	Position 3	Position 4/Position 5
Material ¹⁾ for rubbing surfaces Seal face ²⁾ /seat	Material for flexible elements ³⁾	Materials ¹⁾ for other components, such as springs, metal bellows ⁵⁾ (excluding covers and shaft sleeves)
<p>Manufactured carbons</p> <p>A Carbon, metal-impregnated</p> <p>B Carbon, resin-impregnated</p> <p>C Other carbons</p> <p>Metals</p> <p>D Carbon steel</p> <p>E Cr steel</p> <p>F CrNi steel</p> <p>G CrNiMo steel</p> <p>H Metals with carbide coatings</p> <p>K Hard-coating, metallic</p> <p>M High-nickel alloy</p> <p>N Bronze</p> <p>P Grey cast iron</p> <p>R Alloyed grey cast iron</p> <p>S Cr cast steel</p> <p>T Other metals</p> <p>Carbide (Tungsten carbides U, silicon carbides Q, other carbides J)</p> <p>U1 Tungsten carbides, Co-bonded</p> <p>U2 Tungsten carbides, Ni-bonded</p> <p>U3 Tungsten carbides, CrNiMo-bonded</p> <p>Q1 SiC</p> <p>Q2 SiC-Si</p> <p>Q3 SiC-C-Si, composite</p> <p>Q4 C-SiC, surface-siliconised</p> <p>J Other carbides</p> <p>Metal oxides</p> <p>V Aluminium oxide</p> <p>W Chromium oxide</p> <p>X Other metal oxides</p> <p>Plastics (PTFE, reinforced Y, other plastics Z)</p> <p>Y1 PTFE, glass-fibre reinforced</p> <p>Y2 PTFE, carbon reinforced</p> <p>Z Other plastics</p>	<p>Elastomers, not sheathed⁴⁾</p> <p>B Butyl rubber (IIR)</p> <p>E Ethylene propylene rubber (EPPM)</p> <p>K Perfluoro rubber</p> <p>N Chloroprene rubber (CR)</p> <p>P Nitrile rubber (NBR)</p> <p>S Silicon rubber (MVQ)</p> <p>V Fluoro rubber (FPM)</p> <p>X Other elastomers</p> <p>Elastomers, sheathed</p> <p>M Elastomers/PTFE sheathed</p> <p>Non-elastomers</p> <p>G Graphite</p> <p>T PTFE</p> <p>Y Other non-elastomers</p> <p>Various materials</p> <p>U various materials for flexible elements</p>	<p>D Carbon steel</p> <p>E Cr steel</p> <p>F CrNi steel</p> <p>G CrNiMo steel</p> <p>M High-nickel alloy</p> <p>N Copper-tin alloy (Bronze)</p> <p>T Other materials</p>

- 1) For more detailed data refer to mechanical seals manufacturer's literature
- 2) Seal face = spring loaded axially sliding ring of the mechanical seal
- 3) Flexible elements are seals which seal the rotating components on the shaft/shaft sleeve and the stationary components in the seal housing/end cover, including a bellows when applicable
- 4) Refer to table 2, footnote¹⁾
- 5) For bellows seals any component missing should be designated with a dash "-"

BSI — British Standards Institution

BSI is the independent national body responsible for preparing British Standards. It presents the UK view on standards in Europe and at the international level. It is incorporated by Royal Charter.

Revisions

British Standards are updated by amendment or revision. Users of British Standards should make sure that they possess the latest amendments or editions.

It is the constant aim of BSI to improve the quality of our products and services. We would be grateful if anyone finding an inaccuracy or ambiguity while using this British Standard would inform the Secretary of the technical committee responsible, the identity of which can be found on the inside front cover. Tel: 020 8996 9000. Fax: 020 8996 7400.

BSI offers members an individual updating service called PLUS which ensures that subscribers automatically receive the latest editions of standards.

Buying standards

Orders for all BSI, international and foreign standards publications should be addressed to Customer Services. Tel: 020 8996 9001. Fax: 020 8996 7001. Standards are also available from the BSI website at <http://www.bsi-global.com>.

In response to orders for international standards, it is BSI policy to supply the BSI implementation of those that have been published as British Standards, unless otherwise requested.

Information on standards

BSI provides a wide range of information on national, European and international standards through its Library and its Technical Help to Exporters Service. Various BSI electronic information services are also available which give details on all its products and services. Contact the Information Centre. Tel: 020 8996 7111. Fax: 020 8996 7048.

Subscribing members of BSI are kept up to date with standards developments and receive substantial discounts on the purchase price of standards. For details of these and other benefits contact Membership Administration. Tel: 020 8996 7002. Fax: 020 8996 7001. Further information about BSI is available on the BSI website at <http://www.bsi-global.com>.

Copyright

Copyright subsists in all BSI publications. BSI also holds the copyright, in the UK, of the publications of the international standardization bodies. Except as permitted under the Copyright, Designs and Patents Act 1988 no extract may be reproduced, stored in a retrieval system or transmitted in any form or by any means – electronic, photocopying, recording or otherwise – without prior written permission from BSI.

This does not preclude the free use, in the course of implementing the standard, of necessary details such as symbols, and size, type or grade designations. If these details are to be used for any other purpose than implementation then the prior written permission of BSI must be obtained.

If permission is granted, the terms may include royalty payments or a licensing agreement. Details and advice can be obtained from the Copyright Manager. Tel: 020 8996 7070.