

BS EN 12572-1:2017



BSI Standards Publication

Artificial climbing structures

Part 1: Safety requirements and test methods for ACS with protection points

National foreword

This British Standard is the UK implementation of EN 12572-1:2017. It supersedes BS EN 12572-1:2007 which is withdrawn.

The UK participation in its preparation was entrusted to Technical Committee SW/136/19, Artificial climbing structures.

A list of organizations represented on this committee can be obtained on request to its secretary.

This publication does not purport to include all the necessary provisions of a contract. Users are responsible for its correct application.

© The British Standards Institution 2017.
Published by BSI Standards Limited 2017

ISBN 978 0 580 89899 0

ICS 97.220.10

Compliance with a British Standard cannot confer immunity from legal obligations.

This British Standard was published under the authority of the Standards Policy and Strategy Committee on 31 January 2017.

Amendments/corrigenda issued since publication

Date	Text affected
------	---------------

EUROPEAN STANDARD

EN 12572-1

NORME EUROPÉENNE

EUROPÄISCHE NORM

January 2017

ICS 97.220.10

Supersedes EN 12572-1:2007

English Version

Artificial climbing structures - Part 1: Safety requirements and test methods for ACS with protection points

Structures artificielles d'escalade - Partie 1 : Exigences
de sécurité et méthodes d'essai relatives aux SAE avec
points d'assurage

Künstliche Kletteranlagen - Teil 1:
Sicherheitstechnische Anforderungen und
Prüfverfahren für KKA mit Sicherungspunkten

This European Standard was approved by CEN on 29 October 2016.

CEN members are bound to comply with the CEN/CENELEC Internal Regulations which stipulate the conditions for giving this European Standard the status of a national standard without any alteration. Up-to-date lists and bibliographical references concerning such national standards may be obtained on application to the CEN-CENELEC Management Centre or to any CEN member.

This European Standard exists in three official versions (English, French, German). A version in any other language made by translation under the responsibility of a CEN member into its own language and notified to the CEN-CENELEC Management Centre has the same status as the official versions.

CEN members are the national standards bodies of Austria, Belgium, Bulgaria, Croatia, Cyprus, Czech Republic, Denmark, Estonia, Finland, Former Yugoslav Republic of Macedonia, France, Germany, Greece, Hungary, Iceland, Ireland, Italy, Latvia, Lithuania, Luxembourg, Malta, Netherlands, Norway, Poland, Portugal, Romania, Serbia, Slovakia, Slovenia, Spain, Sweden, Switzerland, Turkey and United Kingdom.



EUROPEAN COMMITTEE FOR STANDARDIZATION
COMITÉ EUROPÉEN DE NORMALISATION
EUROPÄISCHES KOMITEE FÜR NORMUNG

CEN-CENELEC Management Centre: Avenue Marnix 17, B-1000 Brussels

Contents	Page
European foreword.....	3
1 Scope	4
2 Normative references	4
3 Terms and definitions	4
4 Safety requirements and test methods	6
4.1 Layout and placement of individual protection points	6
4.2 Design of individual top protection points	8
4.2.1 General.....	8
4.2.2 Dimensions.....	8
4.3 Structural integrity.....	9
4.3.1 Structural integrity of an ACS	9
4.3.2 Structural integrity of a protection point connection.....	10
4.4 Impact resistance and deflection of surface elements	10
4.5 Panel insert resistance.....	10
4.6 Proof testing.....	10
4.7 Falling space.....	11
4.8 Free space	11
4.9 Climbing surfaces.....	11
5 Marking.....	11
6 Instruction manual.....	12
7 Technical documentation of ACS	12
Annex A (normative) Effects.....	13
Annex B (normative) Method of calculation of structural integrity	15
Annex C (normative) Load testing of structural integrity of protection point connections	17
Annex D (normative) Impact test of surface elements	18
Annex E (normative) Panel insert resistance test.....	21
Annex F (normative) Proof testing.....	23
Annex G (normative) Inspection and maintenance	26
Bibliography.....	28

European foreword

This document (EN 12572-1:2017) has been prepared by Technical Committee CEN/TC 136 “Sports, playground and other recreational facilities and equipment”, the secretariat of which is held by DIN.

This European Standard shall be given the status of a national standard, either by publication of an identical text or by endorsement, at the latest by July 2017, and conflicting national standards shall be withdrawn at the latest by July 2017.

Attention is drawn to the possibility that some of the elements of this document may be the subject of patent rights. CEN shall not be held responsible for identifying any or all such patent rights.

This document supersedes EN 12572-1:2007.

This standard EN 12572, *Artificial climbing structures*, consists of the following parts:

- *Part 1: Safety requirements and test methods for ACS with protection points*
- *Part 2: Safety requirements and test methods for bouldering walls*
- *Part 3: Safety requirements and test methods for climbing holds*

According to the CEN-CENELEC Internal Regulations, the national standards organisations of the following countries are bound to implement this European Standard: Austria, Belgium, Bulgaria, Croatia, Cyprus, Czech Republic, Denmark, Estonia, Finland, Former Yugoslav Republic of Macedonia, France, Germany, Greece, Hungary, Iceland, Ireland, Italy, Latvia, Lithuania, Luxembourg, Malta, Netherlands, Norway, Poland, Portugal, Romania, Serbia, Slovakia, Slovenia, Spain, Sweden, Switzerland, Turkey and the United Kingdom.

1 Scope

This European Standard specifies the safety requirements and test methods for artificial climbing structures with protection points (hereafter referred to as ACS).

This European Standard is applicable for ACS in normal use for sport climbing.

This European Standard is not applicable to ice climbing, dry tooling and playground equipment.

2 Normative references

The following documents, in whole or in part, are normatively referenced in this document and are indispensable for its application. For dated references, only the edition cited applies. For undated references, the latest edition of the referenced document (including any amendments) applies.

EN 1991-1-3, *Eurocode 1 - Actions on structures - Part 1-3: General actions - Snow loads*

EN 1991-1-4, *Eurocode 1: Actions on structures - Part 1-4: General actions - Wind actions*

EN 1991-1-5, *Eurocode 1: Actions on structures - Part 1-5: General actions - Thermal actions*

EN 1998-1, *Eurocode 8: Design of structures for earthquake resistance - Part 1: General rules, seismic actions and rules for buildings*

3 Terms and definitions

For the purposes of this document, the following terms and definitions apply.

3.1 artificial climbing structure (ACS)

sports equipment consisting of a purpose-built climbing structure, which shows various construction characteristics, and is designed for various uses in sport climbing objectives

3.2 protection point

attachment point on the ACS designed to protect the climber

Note 1 to entry: It can be permanent (cannot be removed with tools, e.g. a glue in anchor) or non-permanent (removable with tools, e.g. a hanger).

3.2.1 individual protection point

intermediate protection point used to safeguard a climber in his/her progress on the ACS

3.2.2 individual top protection point

protection point which is fixed at the top of a climbing line and which is designed to take the rope of one climber

Note 1 to entry: It can be used for top rope or lead climbing.

3.3

attachment point

if permanent quick draws are installed the lower point of the device through which the rope passes

Note 1 to entry: Without permanent quick draws the attachment point is the protection point.

3.4

collective top protection system

protection system which is fixed at the top of a climbing line and which is designed to take the ropes of several climbers at once

Note 1 to entry: It can be used for top rope or lead climbing.

3.5

span

part of a collective top rope system measured between two consecutive supports or attachments

Note 1 to entry: See Figure F.2.

3.6

characteristic load

maximum load that can be generated in normal use

3.7

falling space

space on or around the ACS that can be occupied by the user during a fall

3.8

free space

space around the ground projection of the ACS that can be occupied by a climbing, a lowering, spotting or belaying user

3.9

hold

removable climbing component used for progression on an ACS or bouldering wall including bigger three dimensional, structural attachment without additional panel insert or other means of hold fixation

Note 1 to entry: It should be noted that holds bigger than size XXL are called macros (see Table 1).

3.10

volume

removable three dimensional, structural attachment with panel insert or other means of hold fixation designed for temporary extension of the climbing surface

3.11

panel insert

point on which a climbing hold is attached

4 Safety requirements and test methods

4.1 Layout and placement of individual protection points

If there are individual protection points, the height of the first point shall not exceed 3,10 m.

The distance x between the placement of the individual protection points (see Figure 1) from height h shall be determined as follows:

- 1 m if $h \leq 4$ m;
- 1,10 m for $h > 4$ m;
- 1,20 m for $h > 5$ m;
- 1,30 m for $h > 6$ m;
- 1,40 m for $h > 7$ m;
- 1,50 m for $h > 8$ m;
- 2,00 m for $h > 10$ m.

The distance x may have a tolerance of 10 %.

h is the distance between the point and the ground measured vertically, in metres, beneath the point in all cases.

For protection points, the maximum distance shall be measured from the lowest internal point of the attachment point.

If permanent quick draws are installed, the maximum distance shall be measured from lower quick draw end to lower quick draw end. A permanent quick draw (e.g. chain secure element, Maillon Rapide) shall be disassembled from the climbing wall by means of tools (see Figure 2).

Protection points attached with bolts shall be secured, so they cannot come undone, e.g. with lock nuts.

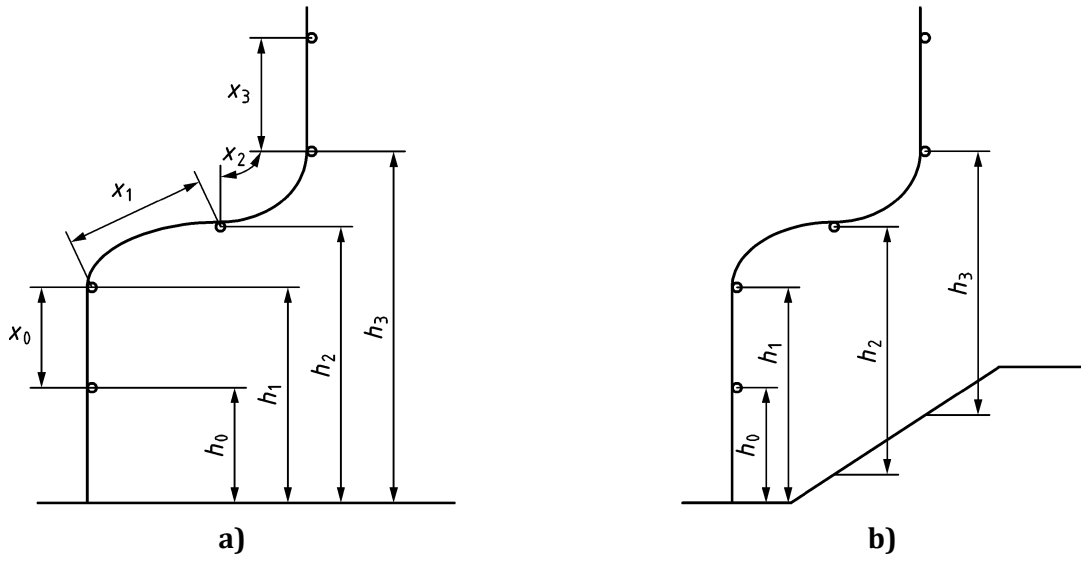

Figure 1 — Layout of protection points

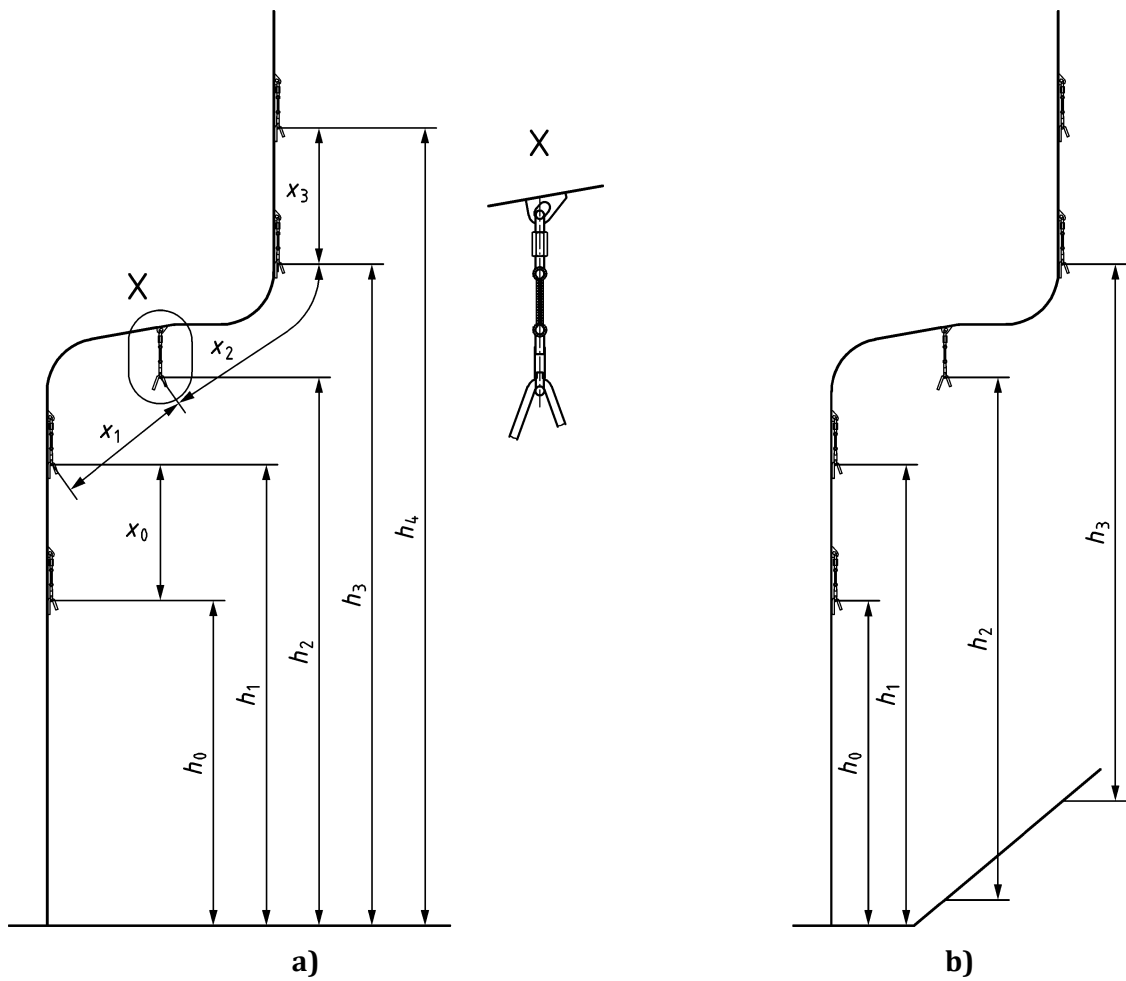

Figure 2 — Design and placement of permanent quick draws

4.2 Design of individual top protection points

4.2.1 General

The rope shall not be able to escape from the top protection points at an untimely moment, e.g. single-snap-gate karabiner is not sufficient.

Individual top protection points shall be attached to the structure by two or more points of fixation. Each fixation point shall be calculated as a protection point.

Each link between the fixing points shall have a resistance greater than or equal to each of the points which it joins together; this resistance shall be verified by either calculation (see Annex A), or a document of compliance, or tests as defined in Annex C.

4.2.2 Dimensions

The minimum dimensions of all protection points and stance points with the exception of individual and collective top protection systems shall be in accordance with Figure 3. Other designs meeting the requirements of Figure 3 are also permissible.

The bar or device over or through which the rope passes in either a collective top protection system or an individual top protection point shall be rounded in accordance with Figure 4.

Dimensions in millimetres

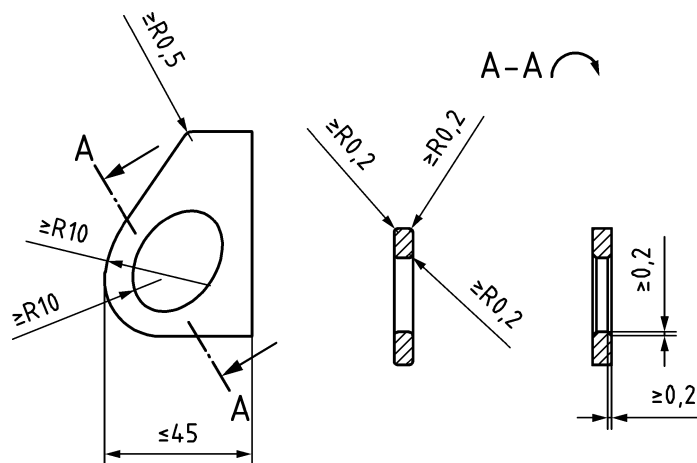

Figure 3 — Design of individual protection points

Dimensions in millimetres

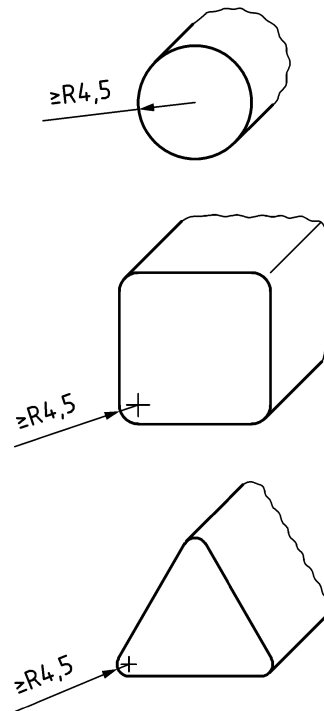

Figure 4 — Rounding of parts

4.3 Structural integrity

4.3.1 Structural integrity of an ACS

The structural integrity and stability of an ACS shall be justified by calculation using the characteristic loads given in Table A.1, in accordance with Annexes A, B and Figure 5. Ensure that the structure (e.g. building, concrete platform and ground) can safely accommodate the loads imposed by the ACS.

Permanent protection points shall be calculated in accordance with Annexes A and B (e.g. glued protection points in concrete walls).

Non-permanent protection points shall have a breaking strength in the main load direction of a minimum of 20 kN.

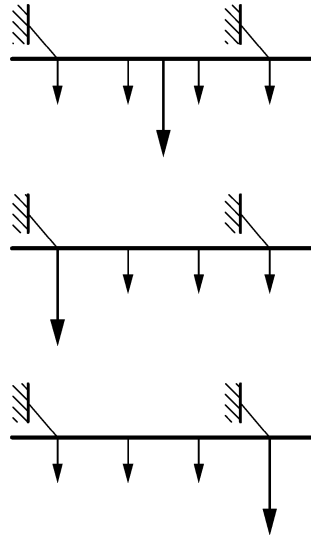

NOTE The larger arrow indicates 6,6 kN. The smaller arrow indicates 1,6 kN.

Figure 5 — Placement of the loads on collective protection systems

4.3.2 Structural integrity of a protection point connection

All elements of an ACS shall be justified by calculation, however in exceptional cases for protection point connections only (the assembly that attaches the actual protection point to the sub frame), a load test as described in Annex C is acceptable as a method of evaluation.

After applying the design load to the protection point connection there shall be no permanent deformation. After applying the breaking load to the protection point connection there shall be no breakage.

4.4 Impact resistance and deflection of surface elements

When tested in accordance with Annex D, there shall be no breaking or splitting of any surface element.

The deflection of the panels shall be calculated by using the load 0,8 kN (see Annex A) or be tested in accordance with Annex D, D.5.

When fixed according to the manufacturer's specification, the maximum deflection of the surface element shall not exceed $l/100$:

where

l is the maximum length between the fixations of the surface.

4.5 Panel insert resistance

To evaluate the panel insert concerning the resistance to breakage while mounting the climbing holds onto the wall or during climbing use, the panel inserts shall be tested in accordance with Annex E.

After test step c) any resulting deformation shall not exceed 0,5 mm at 1,2 kN.

After procedure e) there shall be no pull out of the panel insert.

Five samples (panel-insert combination) shall be tested.

4.6 Proof testing

When tested in accordance with Annex F, after settling under load there shall be no breaking, tearing or destruction of the elements after testing.

4.7 Falling space

Within the falling space there shall not be any exposed obstacles or edges which could lead to a serious hazard to the user. This does not apply to climbing structures and other obstacle-free surfaces or walls capable of withstanding accidental impacts. The horizontal falling space shall be 2 m behind, 1,5 m either side and 8 m below the protection points in accordance with Figure 6.

Dimensions in metres

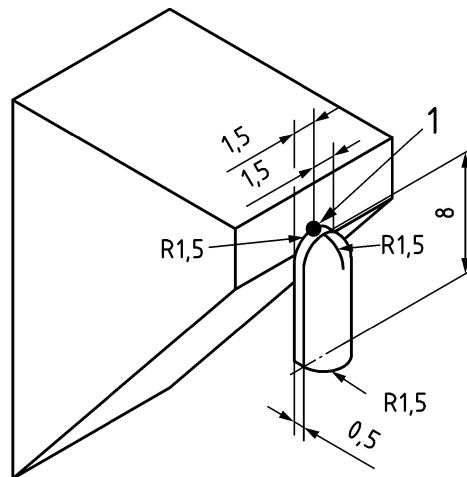

Key

- 1 protection point

Figure 6 — Falling space

4.8 Free space

The free space shall allow the climber to land safely and other users to move without being obstructed by obstacles.

4.9 Climbing surfaces

All reachable parts of the climbing surface shall be free of sharp edges and burrs. Edges where the rope passes shall be designed in order to avoid damage to the rope.

There shall be no gaps between 8 mm and 25 mm and with a depth greater than 15 mm which can lead to entrapment, unless it is a feature specifically designed for climbing. Insert holes in climbing surface of the ACS for attaching holds are excluded.

5 Marking

All ACS shall be marked in a clearly visible place with a notice comprising of:

- name or trademark of the manufacturer;
- name of importer or supplier;
- number and date of this European Standard, i.e. EN 12572-1:2017;
- date of installation of the ACS;
- date of the next main inspection.

6 Instruction manual

An instruction manual shall be provided including the following information:

- a) information contained in Clause 5;
- b) position and type of protection points on the ACS;
- c) maximum number of protection point lines usable simultaneously on the ACS;

The number of protection point lines should equal to number of top protection points. Should the number differ, the manufacturer should give details in the manual and mark the ACS appropriately.

- d) maximum additional load allowed per square meter for large removable elements (e.g. volumes);
- e) specific use, maintenance and inspection requirements, see Annex G.

7 Technical documentation of ACS

The documentation shall be supplied to the client and contain the following information where applicable:

- a) detailed calculation of the stability of the entire structural frame and all protection points;
- b) location of the protection points;
- c) report of the impact test of surface elements;
- d) report of the proof test of the ACS;
- e) report of the protection point connections test according to Annex C, if appropriate;
- f) report of the panel insert resistance test;
- g) marking;
- h) instruction manual.

The proof tests shall be made at the first installation and all reinstallation only.

For all further reconfigurations only the new calculations and visual verifications according to the standard and the manufacturer's instructions are necessary.

Annex A (normative)

Effects

A.1 Permanent effects

The permanent effects consist of the self-weight of the structure and of the entire structural frame.

A.2 Variable effects

A.2.1 General

The variable effects consist of:

- a) user loads (static and falling);
- b) snow loads;
- c) wind loads;
- d) effects of temperature;
- e) seismic loads;
- f) special loads.

A.2.2 User loads

Table A.1 — Loads

Dimensions in Kilonewton

	Proof test load	Characteristi c load	Breaking load
Load of a climber	—	0,8	—
Load produced by falling climber on a protection point ^a	6,6	6,6	20,0
NOTE The proof testing only acts as a verification of good installation practice and cannot replace the calculations.			
^a Based on experiments it is impossible to have two or more climbers create a peak impact force simultaneously due to a fall.			

A.2.3 Snow loads

Snow loads shall be taken from the Eurocodes for actions on structure, i.e. EN 1991-1-3.

A.2.4 Wind loads

Wind loads shall be taken from the Eurocodes for actions on structure, i.e. EN 1991-1-4.

A.2.5 Effects of temperature

Impacts of temperature shall be taken from the Eurocodes for actions on structure, i.e. EN 1991-1-5.

A.2.6 Seismic loads

Seismic loads shall be taken from the Eurocodes for actions on structure, i.e. EN 1998-1.

A.2.7 Special loads

Special loads can be generated e.g. by ropes courses, rescue techniques, zip wires and slacklines.

Annex B (normative)

Method of calculation of structural integrity

B.1 General principles

B.1.1 Limit state

Each structure and structural element, e.g. connections, foundations, supports, shall be calculated taking into account the load combinations of B.2.

The preferred method of calculation shall be based on the general principles and definitions for limit states as specified in the appropriate structural Eurocodes 1 to 6 or equivalent national standards.

NOTE Limit states are states beyond which the structure no longer satisfies the requirements of this European Standard.

In symbolic form, a limit state can be written as:

$$\gamma_F \cdot S \leq R/\gamma_M \quad (\text{B.1})$$

where

- γ_F is a partial safety factor for effects;
- γ_M is a partial safety factor for materials;
- S is load effect;
- R is the resistance of the structure.

In order to allow for uncertainties in the actual loads and in the model used for determining loads, loads are multiplied by a partial safety factor for loads (γ_F).

In order to allow for uncertainties in the actual material properties and in the models used for determining forces in the structure, the strength of the structure is divided by a partial safety factor for materials (γ_M).

B.1.2 Ultimate limit state

Ultimate limit states requiring consideration include:

- a) loss of equilibrium of the structure or any part of it, considered as a rigid body;
- b) failure by excessive deformation, rupture, or loss of stability of the structure or any part of it.

NOTE Ultimate limit states are those associated with collapse, or with other forms of structural failure which can endanger the safety of people.

B.2 Combination effects for the ultimate limit state

The following combinations shall be used for verification:

$$\gamma_G G_k + \gamma_Q Q_{k,1} + \sum_{i>1} \psi_i \gamma_Q Q_{k,i} \quad (\text{B.2})$$

where

- G_k characteristic value for permanent effects;
- Q_k characteristic value for variable effects as given in A.2;
- γ_G partial safety factor for permanent effects;
- γ_Q partial safety factor for variable effects;
- ψ combination factor for variable effects.

The following partial safety factors for effects shall be used:

- γ_G 1,0 for favourable effects;
- γ_G 1,35 for unfavourable effects;
- γ_Q 0 for favourable effects;
- γ_Q 1,5 for unfavourable effects.

In case of several variable effects, the simplified method of calculation with the following combination factor may be used:

$$\psi = 0,8.$$

B.3 Structural stability

For the calculation of integrity and stability of an ACS, the loads of a falling climber shall be applied at the most unfavourable protection point. The load of the climbing team (2 times the load of a climber) shall be taken at the most unfavourable protection point on each successive protection point either side of a falling climber.

For the calculation the loads of both falling climber and the climbing team (2 times the load of a climber) shall be on the most unfavourable angle between $\pm 12,5^\circ$ from the vertical axis.

Annex C (normative)

Load testing of structural integrity of protection point connections

C.1 General

This test is designed to evaluate the static strength of protection point connections of an ACS alternatively, when not calculable. By loading with the design load no permanent deformation is acceptable. By loading with the breaking load no break is acceptable.

C.2 Apparatus

Strength measurement device, loading hook \varnothing 12 mm.

C.3 Sampling

The relevant protection point connection and the necessary ACS background structure to be tested shall have been produced using the same materials and by the same manufacturing process as the elements of the ACS it represents.

C.4 Procedure

Set up the relevant protection point connection with the necessary background structure as intended in the relevant ACS.

Load the protection point connection in the direction of a fall. Apply a load corresponding to the design load (characteristic load \times 1,5) (\pm 1 %) to the protection point connection for 1 min (\pm 5 s). There is no permanent deformation acceptable.

Settling of the protection point connection is acceptable.

Continue testing by applying a load corresponding to the breaking load (\pm 1 %) of Table A.1 to the protection point connection for 1 min (\pm 5 s).

There shall be no breakage acceptable which leads to the failure of the protection point connection.

Annex D (normative)

Impact test of surface elements

D.1 General

This test is designed to reproduce a shock perpendicular to the surface of the ACS, when the ACS is used under normal conditions.

D.2 Apparatus

Indenter in accordance with Figure D.1.

D.3 Sampling

The surface elements to be tested shall have been produced using the same materials and by the same manufacturing processes as the elements of the ACS it represents. The sample shall be a standard element or a specially made flat panel 1 000 mm × 1 000 mm.

D.4 Procedure

Set up the surface element as shown in Figure D.2.

Place the surface element on rigid supporting points as following:

- a) for a surface element: as it would be on an ACS;
- b) for a sample: at each corner, with a non-shock absorbing system.

Strike the surface of the element three times with the indenter in the geometric centre from a height of 1 500 mm as shown in Figure D.2 a) or b).

There shall be no breakage or splitting of the surface element by the end of the test.

D.5 Maximum deflection

The maximum deflection may be determined by theoretical calculation or empirically. For testing use test samples according to D.3 and apply a force of 0,8 kN normal to the surface and measure the maximum deflection.

Dimensions in millimetres

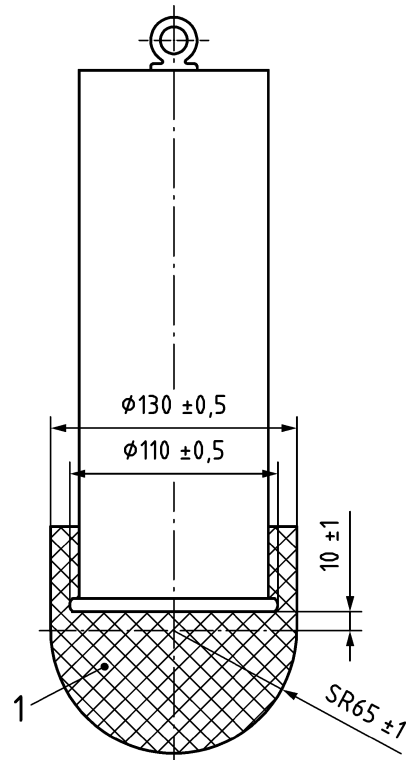

Key

- 1 silicon ((30 ± 5) shores)
total mass ($22 \pm 0,1$) kg

Figure D.1 — Indenter

Dimensions in millimetres

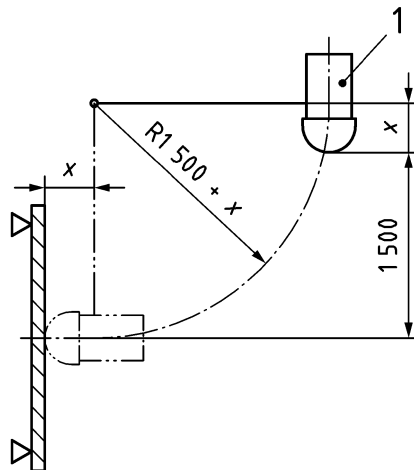

a) horizontal impact test on vertical surface

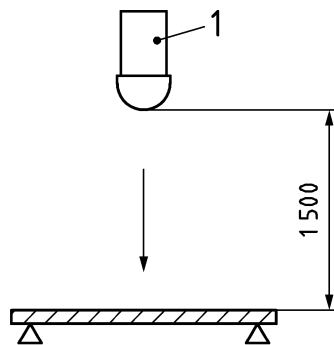

b) vertical impact test on horizontal surface

Key

1 indenter

x distance to fixing point

Figure D.2 — Set up of surface elements for impact test

Annex E (normative)

Panel insert resistance test

E.1 General

This test is designed to reproduce the maximum load that can be applied to a panel insertion a ACS due to the force of a fixed climbing hold and the maximum permissible force exerted by a climber during use.

E.2 Apparatus

Eyebolt/ threaded bar, distance ring and pulling apparatus in accordance with Figure E.1.

E.3 Sampling

The surface elements to be tested shall have been produced using the same materials and by the same manufacturing processes as the elements of the ACS it represents.

E.4 Procedure

Carry out the test as follows:

- a) load the sample up to $(7,2 \pm 0,05)$ kN at a rate of (20 ± 2) mm/min;
- b) hold the load for 30 s;
- c) relieve down to $(1,2 \pm 0,05)$ kN, and measure the deformation;
- d) hold the load of $(1,2 \pm 0,05)$ kN for 30 s;
- e) load the sample up to $(12 \pm 0,05)$ kN at a rate of (20 ± 2) mm/min;

Carry out the test under the following conditions: (23 ± 2) °C and (50 ± 10) % relative humidity.

Dimensions in millimetres

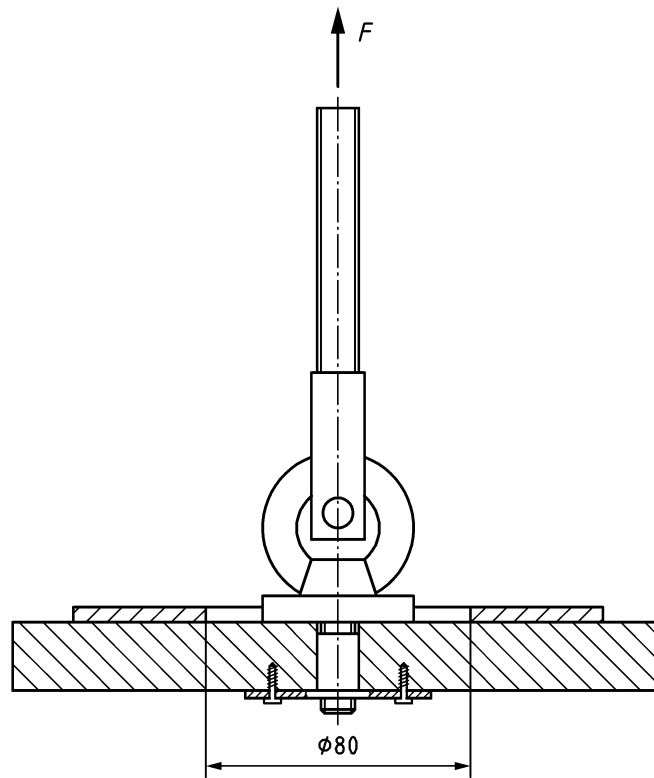

Key

F force

Figure E.1 — Apparatus

Annex F (normative)

Proof testing

F.1 General

These tests shall be used as a verification of good installation practice and shall not in any case replace the calculations, maintenance programme, inspection or other justification procedure. There is no requirement for future retesting of the ACS, after the first installation of the ACS.

F.2 Procedure

F.2.1 General

During tests, the forces used shall be in the direction of a fall $\pm 12,5^\circ$ from the vertical axis, or roughly parallel to the surface of the ACS if its incline is greater than $12,5^\circ$ (see Figure F.1).

During tests, apply the forces either by suspending a mass, or by using traction devices not resting directly on the ACS.

The equipment for the application of the load when testing shall be applied by devices wide enough not to damage the elements tested.

In all proof tests, apply the force quasi-statically for at least 10 s.

F.2.2 Protection points

F.2.2.1 Individual protection point

Test the first three protection points of each climbing route.

The highest protection point of each climbing route shall be considered as an individual top rope system and shall be tested.

The test load is 6,6 kN.

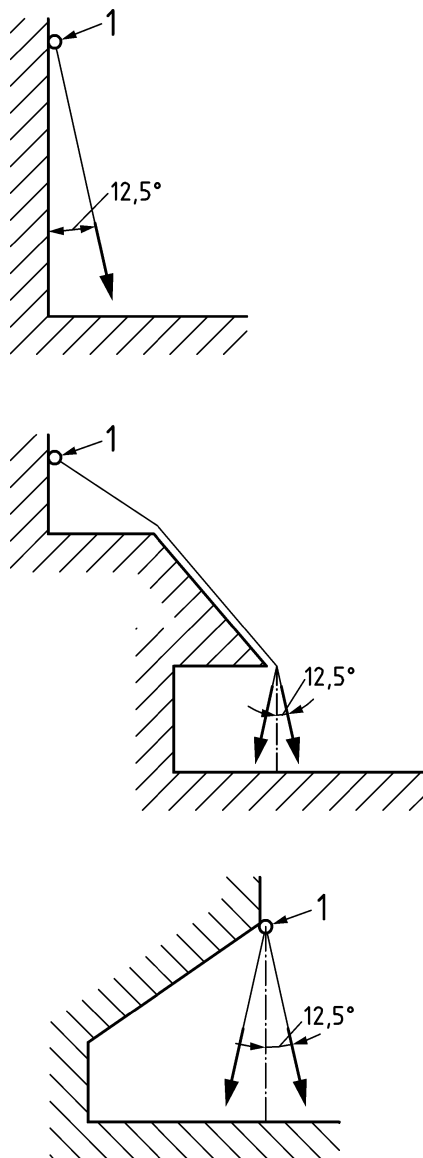

Key

1 point tested

Figure F.1 — Maximum angle for the direction of the forces

F.2.2.2 Individual top protection points

All individual top protection points shall be tested.

All the points designed to pass the rope through shall be tested.

The test load is 6,6 kN.

F.2.2.3 Collective top protection system

Test every collective top protection system in accordance with Figure F.3 as follows:

- a) test at the points of fixation;
- b) test in the middle of each span (see Figure F.2);

- c) test at the point where the load makes the greatest bending moment;
- d) for all tests the load is 6,6 kN.

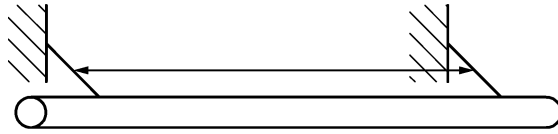

Figure F.2 — Span

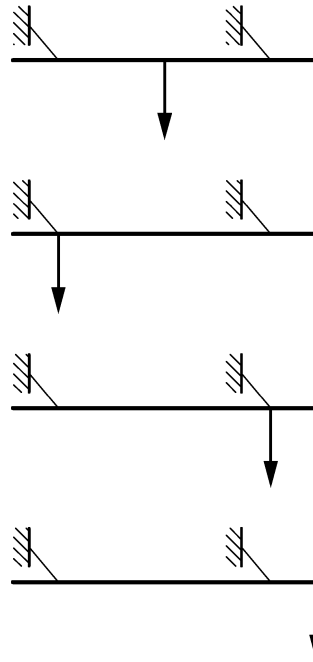

Figure F.3 — Placement of test loads for collective top protection systems

Annex G (normative)

Inspection and maintenance

G.1 The manufacturer/supplier shall provide:

- a) instructions for maintenance (marked with the number of the current standard), which shall include a statement that the frequency of inspection will vary with the type of equipment or materials used and other factors, e.g. heavy use, levels of vandalism, coastal location, air pollution, age of equipment;
- b) drawings and diagrams necessary for maintenance, inspection and checking of the correct operation and, when appropriate, repair of the equipment;
- c) instructions to specify how access is to be gained to the inside of each section of the ACS where applicable.

G.2 The instructions shall specify the frequency with which the equipment or its components should be inspected or maintained and shall include guidance on the following, where relevant:

- a) Routine visual inspection

The routine visual inspection serves to identify obvious defects and sources of danger on the front side of the climbing wall, which can be easily seen from the ground without use of means of support. For ACS subject to heavy use or vandalism, daily inspection of this type may be necessary.

NOTE 1 Examples of visual and operational inspection points are cleanliness, loose holds, obstacles placed in the free space, missing parts, excessive wear and other obvious damage.

- b) Operational inspection

The operational inspection is a more detailed inspection to check the operation and stability of the equipment, and for the wear of components. This shall be carried out every 1 to 3 months, or as indicated by the manufacturer's instructions. Operational inspections shall be documented.

Special attention shall be given to protection points and the mechanisms of articulated walls.

- c) Main inspection

The main inspection, according to the maintenance manual of the relevant manufacturer, is done to establish the overall level of safety of the ACS, its foundations, structural frame and wall surfaces, e.g. effects of weather, evidence of rotting or corrosion, and any change in the level of safety of the equipment as a result of repairs made, or of added or replaced components. Main inspections shall be documented.

Special attention shall be given to all protection systems, the structural frame and generally the inside of the ACS.

The main inspection may require dismantling of certain parts and replacement of critical safety elements. This inspection of the equipment should be carried out by competent persons in strict accordance with the manufacturer's instructions.

NOTE 2 The level of competence required will vary with the task.

G.3 The instructions shall also specify the following:

- a) where necessary, the servicing points and methods of servicing, e.g. lubrication, tightening of bolts, re-tensioning of ropes;
- b) replacement parts shall comply with manufacturer's specifications;
- c) if special disposal treatment is required for some equipment or parts;
- d) identification of spare parts;
- e) additional measures to be taken during the run-in period, e.g. tightening of fastenings, tensioning of cables, lubrication of moving parts;
- f) special points the manufacturer wants the operator to pay particular attention to.

Bibliography

- [1] EN ISO/IEC 17020, *Conformity assessment - Requirements for the operation of various types of bodies performing inspection (ISO/IEC 17020)*
- [2] EN ISO/IEC 17025, *General requirements for the competence of testing and calibration laboratories (ISO/IEC 17025)*

British Standards Institution (BSI)

BSI is the national body responsible for preparing British Standards and other standards-related publications, information and services.

BSI is incorporated by Royal Charter. British Standards and other standardization products are published by BSI Standards Limited.

About us

We bring together business, industry, government, consumers, innovators and others to shape their combined experience and expertise into standards-based solutions.

The knowledge embodied in our standards has been carefully assembled in a dependable format and refined through our open consultation process. Organizations of all sizes and across all sectors choose standards to help them achieve their goals.

Information on standards

We can provide you with the knowledge that your organization needs to succeed. Find out more about British Standards by visiting our website at bsigroup.com/standards or contacting our Customer Services team or Knowledge Centre.

Buying standards

You can buy and download PDF versions of BSI publications, including British and adopted European and international standards, through our website at bsigroup.com/shop, where hard copies can also be purchased.

If you need international and foreign standards from other Standards Development Organizations, hard copies can be ordered from our Customer Services team.

Copyright in BSI publications

All the content in BSI publications, including British Standards, is the property of and copyrighted by BSI or some person or entity that owns copyright in the information used (such as the international standardization bodies) and has formally licensed such information to BSI for commercial publication and use.

Save for the provisions below, you may not transfer, share or disseminate any portion of the standard to any other person. You may not adapt, distribute, commercially exploit, or publicly display the standard or any portion thereof in any manner whatsoever without BSI's prior written consent.

Storing and using standards

Standards purchased in soft copy format:

- A British Standard purchased in soft copy format is licensed to a sole named user for personal or internal company use only.
- The standard may be stored on more than 1 device provided that it is accessible by the sole named user only and that only 1 copy is accessed at any one time.
- A single paper copy may be printed for personal or internal company use only.

Standards purchased in hard copy format:

- A British Standard purchased in hard copy format is for personal or internal company use only.
- It may not be further reproduced – in any format – to create an additional copy. This includes scanning of the document.

If you need more than 1 copy of the document, or if you wish to share the document on an internal network, you can save money by choosing a subscription product (see 'Subscriptions').

Reproducing extracts

For permission to reproduce content from BSI publications contact the BSI Copyright & Licensing team.

Subscriptions

Our range of subscription services are designed to make using standards easier for you. For further information on our subscription products go to bsigroup.com/subscriptions.

With **British Standards Online (BSOL)** you'll have instant access to over 55,000 British and adopted European and international standards from your desktop. It's available 24/7 and is refreshed daily so you'll always be up to date.

You can keep in touch with standards developments and receive substantial discounts on the purchase price of standards, both in single copy and subscription format, by becoming a **BSI Subscribing Member**.

PLUS is an updating service exclusive to BSI Subscribing Members. You will automatically receive the latest hard copy of your standards when they're revised or replaced.

To find out more about becoming a BSI Subscribing Member and the benefits of membership, please visit bsigroup.com/shop.

With a **Multi-User Network Licence (MUNL)** you are able to host standards publications on your intranet. Licences can cover as few or as many users as you wish. With updates supplied as soon as they're available, you can be sure your documentation is current. For further information, email subscriptions@bsigroup.com.

Revisions

Our British Standards and other publications are updated by amendment or revision.

We continually improve the quality of our products and services to benefit your business. If you find an inaccuracy or ambiguity within a British Standard or other BSI publication please inform the Knowledge Centre.

Useful Contacts

Customer Services

Tel: +44 345 086 9001

Email (orders): orders@bsigroup.com

Email (enquiries): cservices@bsigroup.com

Subscriptions

Tel: +44 345 086 9001

Email: subscriptions@bsigroup.com

Knowledge Centre

Tel: +44 20 8996 7004

Email: knowledgecentre@bsigroup.com

Copyright & Licensing

Tel: +44 20 8996 7070

Email: copyright@bsigroup.com

BSI Group Headquarters

389 Chiswick High Road London W4 4AL UK