

# Flanges and their joints — Gaskets for Class-designated flanges —

## Part 5: Metallic ring joint gaskets for use with steel flanges

The European Standard EN 12560-5:2001 has the status of a  
British Standard

ICS 23.040.80

## National foreword

This British Standard is the official English language version of EN 12560-5:2001. It supersedes BS 7076-2:1989 which is withdrawn.

The UK participation in its preparation was entrusted to Technical Committee PSE/2, Jointing material and compounds, which has the responsibility to:

- aid enquirers to understand the text;
- present to the responsible European committee any enquiries on the interpretation, or proposals for change, and keep the UK interests informed;
- monitor related international and European developments and promulgate them in the UK.

A list of organizations represented on this committee can be obtained on request to its secretary.

### Cross-references

The British Standards which implement international or European publications referred to in this document may be found in the BSI Standards Catalogue under the section entitled "International Standards Correspondence Index", or by using the "Find" facility of the BSI Standards Electronic Catalogue.

A British Standard does not purport to include all the necessary provisions of a contract. Users of British Standards are responsible for their correct application.

**Compliance with a British Standard does not of itself confer immunity from legal obligations.**

This British Standard, having been prepared under the direction of the Engineering Sector Committee, was published under the authority of the Standards Committee and comes into effect on 15 March 2001

### Summary of pages

This document comprises a front cover, an inside front cover, the EN title page, pages 2 to 15 and a back cover.

The BSI copyright date displayed in this document indicates when the document was last issued.

### Amendments issued since publication

Amd. No.	Date	Comments

© BSI 03-2001

ISBN 0 580 37047 X

ICS 23.040.80

English version

Flanges and their joints — Gaskets for Class-designated  
flanges — Part 5: Metallic ring joint gaskets for use with steel  
flanges

Brides et leurs assemblages — Joints pour les brides  
désignées Class — Partie 5: Joints annulaires métalliques  
pour utilisation avec des brides en acier

Flansche und ihre Verbindungen — Dichtungen für  
Flansche mit Class-Bezeichnung — Teil 5: RTJ-Dichtungen  
aus Metall für Stahlflansche

This European Standard was approved by CEN on 28 December 2000.

CEN members are bound to comply with the CEN/CENELEC Internal Regulations which stipulate the conditions for giving this European Standard the status of a national standard without any alteration. Up-to-date lists and bibliographical references concerning such national standards may be obtained on application to the Management Centre or to any CEN member.

This European Standard exists in three official versions (English, French, German). A version in any other language made by translation under the responsibility of a CEN member into its own language and notified to the Management Centre has the same status as the official versions.

CEN members are the national standards bodies of Austria, Belgium, Czech Republic, Denmark, Finland, France, Germany, Greece, Iceland, Ireland, Italy, Luxembourg, Netherlands, Norway, Portugal, Spain, Sweden, Switzerland and United Kingdom.



EUROPEAN COMMITTEE FOR STANDARDIZATION  
COMITÉ EUROPÉEN DE NORMALISATION  
EUROPÄISCHES KOMITEE FÜR NORMUNG

Management Centre: rue de Stassart, 36 B-1050 Brussels

## Contents

Page

<b>Foreword</b> .....	<b>3</b>
<b>Introduction</b> .....	<b>4</b>
<b>1</b> <b>Scope</b> .....	<b>5</b>
<b>2</b> <b>Normative references</b> .....	<b>5</b>
<b>3</b> <b>Terms and definitions</b> .....	<b>5</b>
<b>3.1</b> <b>NPS</b> .....	<b>5</b>
<b>3.2</b> <b>Class</b> .....	<b>5</b>
<b>4</b> <b>Designations</b> .....	<b>6</b>
<b>4.1</b> <b>Range of Class designations</b> .....	<b>6</b>
<b>4.2</b> <b>Range of gasket sizes</b> .....	<b>6</b>
<b>4.3</b> <b>Gasket types</b> .....	<b>6</b>
<b>4.4</b> <b>Identification number</b> .....	<b>6</b>
<b>4.5</b> <b>Information to be supplied by the purchaser</b> .....	<b>6</b>
<b>5</b> <b>Gasket types</b> .....	<b>7</b>
<b>6</b> <b>Dimensions and tolerances</b> .....	<b>9</b>
<b>6.1</b> <b>Dimensions</b> .....	<b>9</b>
<b>6.2</b> <b>Tolerances</b> .....	<b>9</b>
<b>7</b> <b>Surface finish</b> .....	<b>13</b>
<b>8</b> <b>Marking</b> .....	<b>14</b>
<b>Annex A</b> (informative) <b>Gasket materials</b> .....	<b>15</b>

## Foreword

This European Standard has been prepared by Technical Committee CEN/TC 74, Flanges and their joints, the Secretariat of which is held by DIN.

This European Standard shall be given the status of a national standard, either by publication of an identical text or by endorsement, at the latest by July 2001, and conflicting national standards shall be withdrawn at the latest by July 2001.

According to the CEN/CENELEC Internal Regulations, the national standards organizations of the following countries are bound to implement this European Standard: Austria, Belgium, Czech Republic, Denmark, Finland, France, Germany, Greece, Iceland, Ireland, Italy, Luxembourg, Netherlands, Norway, Portugal, Spain, Sweden, Switzerland and the United Kingdom.

The annex A is informative.

## Introduction

EN 12560 consists of seven parts:

Part 1: Non-metallic flat gaskets with or without inserts

Part 2: Spiral wound gaskets for use with steel flanges

Part 3: Non-metallic PTFE envelope gaskets

Part 4: Corrugated, flat or grooved metallic and filled metallic gaskets for use with steel flanges

Part 5: Metallic ring-joint gaskets for use with steel flanges

Part 6: Kammprofile gaskets for use with steel flanges

Part 7: Covered metal jacketed gaskets for use with steel flanges

The terminology and definitions in this standard are in accordance with those given in ISO Standards.

## 1 Scope

This European Standard specifies the dimensions and marking of metallic ring-joint gaskets for use in conjunction with specific flange facings (type J) of flanges complying with prEN 1759-1:2000 for Class 150, Class 300, Class 600, Class 900 and Class 1 500 for nominal sizes DN 15 to DN 600, and for Class designation 2 500 up to and including DN 300.

NOTE 1 Dimensions of other types of gaskets for use with flanges complying with prEN 1759-1:2000, prEN 1759-3:1994 and prEN 1759-4:1997 are given in prEN 12560-1:2000, prEN 12560-2:2000, prEN 12560-3:2000, prEN 12560-4:2000, prEN 12560-6:2000 and prEN 12560-7:2000.

NOTE 2 The materials for metallic ring-joint gaskets are outside the scope of this standard, but guidance on typical materials and their hardnesses is given in annex A.

## 2 Normative references

This European Standard incorporates by dated or undated reference, provisions from other publications. These normative references are cited at the appropriate places in the text and the publications are listed hereafter. For dated references, subsequent amendments to or revisions of any of these publications apply to this European Standard only when incorporated in it by amendment or revision. For undated references the latest edition of the publication referred to applies (including amendments).

prEN 1759-1:2000

*Flanges and their joints — Circular flanges for pipes, valves, fittings and accessories, Class designated — Part 1: Steel flanges, NPS 2 to NPS 24*

EN ISO 4287

*Geometrical product specification (GPS) — Surface texture : Profile method — Terms, definitions and surface texture parameters (ISO 4287:1997)*

prEN 1759-3:1994

*Flanges and their joints — Circular flanges for pipes, valves, fittings and accessories, Class designated — Part 3 : Copper alloy flanges*

prEN 1759-4:1997

*Flanges and their joints — Circular flanges for pipes, valves, fittings and accessories, Class designated — Part 4: Aluminium alloy*

## 3 Terms and definitions

For the purposes of this European Standard, the following terms and definitions apply:

### 3.1

#### **NPS**

see prEN 1759-3:1994

### 3.2

#### **Class**

see prEN 1759-3:1994

## 4 Designations

### 4.1 Range of Class designations

Gaskets shall be designated as suitable for use with one or more of the following Class designations of flange:

- Class 150;
- Class 300;
- Class 600;
- Class 900;
- Class 1 500;
- Class 2 500.

### 4.2 Range of gasket sizes

Gasket nominal sizes shall be designated in accordance with Table 1.

### 4.3 Gasket types

Gasket types, as defined in clause 5 and illustrated in Figure 2, shall be designated as either “oval” or “octagonal”.

### 4.4 Identification number

Each metallic ring-joint gasket is assigned an identification number, prefixed by “R”, as shown in Table 1.

NOTE The nominal size(s) and Class designation(s) to which each identification number is relevant is given in Table 1.

### 4.5 Information to be supplied by the purchaser

The following information shall be supplied by the purchaser when ordering gaskets:

- a) the number and Part of this European Standard, i.e. EN 12560-5;
- b) whether a particular cross-sectional shape i.e. oval or octagonal, is required (see clause 5);
- c) the identification ring number (see 4.4 and Table 1);
- d) the material (see annex A);

Additional information that should be supplied by the purchaser :

- e) the expected operating conditions for which the gasket will be used.

NOTE Before ordering a gasket it is recommended that the selection of the gasket type shall be made in consultation with the gasket supplier. The selection of gasket type should take account of the fluid, the operating conditions, the properties of the gasket materials, the type and surface finish of the flange facing and the flange bolt loading.

EXAMPLE A gasket according to EN 12560-5, oval type, with ring number R.36 in type X12Cr13 (Identification symbol S 410) shall be designated as follows :

Gasket EN 12560-5 — oval — R.36 — S 410.



## 5 Gasket types

Metallic ring-joint gaskets for use with ring-joint (type J) flange facings complying with prEN 1759-1:2000 shall have a cross-sectional shape that is either oval or octagonal.

NOTE 1 Figure 1 a) shows a flange joint with an oval type gasket and Figure 1 b) with an octagonal type gasket.

NOTE 2 Figure 2 shows the design of oval type and octagonal type gaskets.

NOTE 3 Ring-joint gaskets of individual identification numbers are applicable to certain nominal size(s) and Class designation(s), as given in Table 1.

NOTE 4 If the purchaser requires a ring-joint gasket with a particular cross-sectional shape, i.e. either oval or octagonal, then this requirement should be stated in the enquiry and/or order (see 4.5). In the absence of this requirement being stated, the type will be at the discretion of the manufacturer.

NOTE 5 The selection of the gasket should take into account the fluid, the operating conditions, the properties of the gasket materials, the type and surface finish of the flange facing and the flange bolt loading. It is recommended that selection of gaskets for any particular application is made in consultation with the gasket supplier (see 4.5).

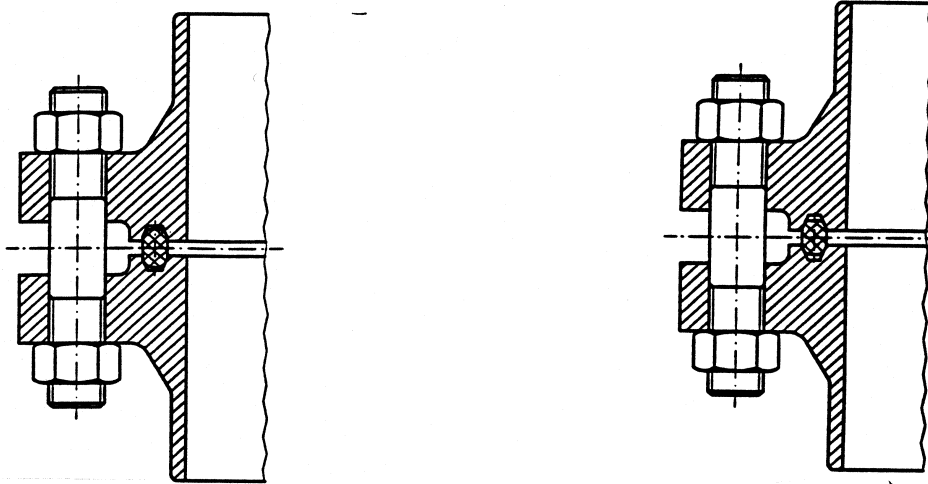

a) oval type

b) octagonal type

Figure 1 — Details of metallic ring-joint gaskets as housed

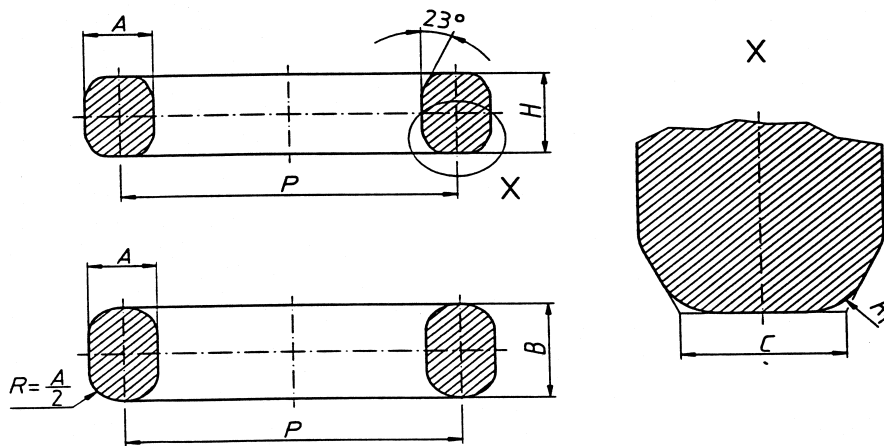

**Key**

- A Width of ring
- B Oval
- C Width on flat of octagonal ring
- P Average pitch diameter of ring
- H Octagonal

- $R_1 = 1,6 \text{ mm}$  for  $A \leq 22,3 \text{ mm}$
- $R_1 = 2,4 \text{ mm}$  for  $A > 22,3 \text{ mm}$

Figure 2 — Gasket dimensions

## 6 Dimensions and tolerances

### 6.1 Dimensions

The dimensions of metallic ring-joint gaskets shall be as given in Table 1 and Figure 2.

NOTE Dimensions of grooves and gaskets are such that, when joints are assembled, the flanges are apart and the approximate distances which the flanges are apart for each Class designation are given in the appropriate table of prEN 1759-1:2000.

### 6.2 Tolerances

The tolerances given in Table 2 shall apply for the dimensions as shown in Figure 2.

NOTE The presence of a small forging fin, located so that it does not prevent the ring from seating properly in the groove, is acceptable.

**Table 1 — Ring numbers and dimensions of metallic ring-joint gaskets**

Flange Class designation					Ring number, <i>r</i>	Average pitch diameter of ring, <i>P</i>	Width of ring, <i>A</i>	Height of ring		Width on flat of octagonal ring, <i>C</i>
150	300 and 600	900	1 500	2 500				Oval, <i>B</i>	Octagonal, <i>H</i>	
Nominal size, DN					mm	mm	mm	mm	mm	
-	15	-	-	-	R.11	34,13	6,35	11,11	9,53	4,32
-	-	15	15	-	R.12	39,69	7,94	14,29	12,70	5,23
-	20	-	-	15	R.13	42,86	7,94	14,29	12,70	5,23
-	-	20	20	-	R.14	44,45	7,94	14,29	12,70	5,23
25	-	-	-	-	R.15	47,63	7,94	14,29	12,70	5,23
-	25	25	25	20	R.16	50,80	7,94	14,29	12,70	5,23
32	-	-	-	-	R.17	57,15	7,94	14,29	12,70	5,23
-	32	32	32	25	R.18	60,33	7,94	14,29	12,70	5,23
40	-	-	-	-	R.19	65,09	7,94	14,29	12,70	5,23
-	40	40	40	-	R.20	68,26	7,94	14,29	12,70	5,23
-	-	-	-	32	R.21	72,23	11,11	17,46	15,88	7,75
50	-	-	-	-	R.22	82,55	7,94	14,29	12,70	5,23
-	50	-	-	40	R.23	82,55	11,11	17,46	15,88	7,75
-	-	50	50	-	R.24	95,25	11,11	17,46	15,88	7,75
65	-	-	-	-	R.25	101,60	7,94	14,29	12,70	5,23
-	65	-	-	50	R.26	101,60	11,11	17,46	15,88	7,75
-	-	65	65	-	R.27	107,95	11,11	17,46	15,88	7,75
-	-	-	-	65	R.28	111,13	12,70	19,05	17,46	8,66
80	-	-	-	-	R.29	114,30	7,94	14,29	12,70	5,23
-	80 <sup>a</sup>	-	-	-	R.30	117,48	11,11	17,46	15,88	7,75
-	80 <sup>b</sup>	80	-	-	R.31	123,83	11,11	17,46	15,88	7,75
-	-	-	-	80	R.32	127,00	12,70	19,05	17,46	8,66

<sup>a</sup> For ring joints with loose hubbed flanges for lapped pipe ends (type 15 flanges) only.

<sup>b</sup> For flanges other than loose hubbed flanges for lapped pipe ends.

(Continued)

**Table 1** (continued)

Flange Class designation					Ring number, <i>r</i>	Average pitch diameter of ring, <i>P</i>	Width of ring, <i>A</i>	Height of ring		Width on flat of octagonal ring, <i>C</i>
150	300 and 600	900	1 500	2 500				Oval, <i>B</i>	Octagonal, <i>H</i>	
Nominal size, DN						mm	mm	mm	mm	mm
-	-	-	80	-	R.35	136,53	11,11	17,46	15,88	7,75
100	-	-	-	-	R.36	149,23	7,94	14,29	12,70	5,23
-	100	100	-	-	R.37	149,23	11,11	17,46	15,88	7,75
-	-	-	-	100	R.38	157,16	15,88	22,23	20,64	10,49
-	-	-	100	-	R.39	161,93	11,11	17,46	15,88	7,75
125	-	-	-	-	R.40	171,45	7,94	14,29	12,70	5,23
-	125	125	-	-	R.41	180,98	11,11	17,46	15,88	7,75
-	-	-	-	125	R.42	190,50	19,05	25,40	23,81	12,32
150	-	-	-	-	R.43	193,68	7,94	14,29	12,70	5,23
-	-	-	125	-	R.44	193,68	11,11	17,46	15,88	7,75
-	150	150	-	-	R.45	211,14	11,11	17,46	15,88	7,75
-	-	-	150	-	R.46	211,14	12,70	19,05	17,46	8,66
-	-	-	-	150	R.47	228,60	19,05	25,40	23,81	12,32
200	-	-	-	-	R.48	247,65	7,94	14,29	12,70	5,23
-	200	200	-	-	R.49	269,88	11,11	17,46	15,88	7,75
-	-	-	200	-	R.50	269,88	15,88	22,23	20,64	10,49
-	-	-	-	200	R.51	279,40	22,23	28,58	26,99	14,81
250	-	-	-	-	R.52	304,80	7,94	14,29	12,70	5,23
-	250	250	-	-	R.53	323,85	11,11	17,46	15,88	7,75
-	-	-	250	-	R.54	323,85	15,88	22,23	20,64	10,49
-	-	-	-	250	R.55	342,90	28,58	36,51	34,93	19,81
300	-	-	-	-	R.56	381,00	7,94	14,29	12,70	5,23
-	300	300	-	-	R.57	381,00	11,11	17,46	15,88	7,75

(Continued)

**Table 1** (concluded)

Flange Class designation					Ring number, <i>r</i>	Average pitch diameter of ring, <i>P</i>	Width of ring, <i>A</i>	Height of ring		Width on flat of octagonal ring, <i>C</i>
150	300 and 600	900	1 500	2 500				Oval, <i>B</i>	Octagonal, <i>H</i>	
Nominal size, DN					mm	mm	mm	mm	mm	
-	-	-	300	-	R.58	381,00	22,23	28,58	26,99	14,81
350	-	-	-	-	R.59	396,88	7,94	14,29	12,70	5,23
-	-	-	-	300	R.60	406,40	31,75	39,69	38,10	22,33
-	350	-	-	-	R.61	419,10	11,11	17,46	15,88	7,75
-	-	350	-	-	R.62	419,10	15,88	22,23	20,64	10,49
-	-	-	350	-	R.63	419,10	25,40	33,34	31,75	17,30
400	-	-	-	-	R.64	454,03	7,94	14,29	12,70	5,23
-	400	-	-	-	R.65	469,90	11,11	17,46	15,88	7,75
-	-	400	-	-	R.66	469,90	15,88	22,23	20,64	10,49
-	-	-	400	-	R.67	469,90	28,58	36,51	34,93	19,81
450	-	-	-	-	R.68	517,53	7,94	14,29	12,70	5,23
-	450	-	-	-	R.69	533,40	11,11	17,46	15,88	7,75
-	-	450	-	-	R.70	533,40	19,05	25,40	23,81	12,32
-	-	-	450	-	R.71	533,40	28,58	36,51	34,93	19,81
500	-	-	-	-	R.72	558,80	7,94	14,29	12,70	5,23
-	500	-	-	-	R.73	584,20	12,70	19,05	17,46	8,66
-	-	500	-	-	R.74	584,20	19,05	25,40	23,81	12,32
-	-	-	500	-	R.75	584,20	31,75	39,69	38,10	22,33
600	-	-	-	-	R.76	673,10	7,94	14,29	12,70	5,23
-	600	-	-	-	R.77	692,15	15,88	22,23	20,64	10,49
-	-	600	-	-	R.78	692,15	25,40	33,34	31,75	17,30
-	-	-	600	-	R.79	692,15	34,93	44,45	41,28	24,82

**Table 2 — Tolerances**

Symbol	Designation	Tolerance
<i>P</i>	Average pitch diameter of ring	± 0,18 mm
<i>A</i>	Width of ring	± 0,20 mm
<i>B</i> and <i>H</i>	Height of ring	± 0,40 mm <sup>a</sup>
<i>C</i>	Width on flat of octagonal ring	± 0,20 mm
<i>R</i> <sub>1</sub>	Angle 23°	± 0,5°
	Radius of ring	± 0,40 mm

<sup>a</sup> A plus tolerance of 1,20 mm for *B* and *H* may apply provided the variation in the height of any given ring does not exceed 0,40 mm throughout its circumference.

## 7 Surface finish

When compared by visual or tactile means with reference specimens, the surface finish of the 23° surfaces of octagonal gaskets and the contact faces of oval gaskets shall be as given in Table 3.

NOTE Is not intended that instrument measurements be taken on the faces themselves; the *R*<sub>a</sub> and *R*<sub>z</sub> values as defined in EN ISO 4287 relate to the reference specimens.

**Table 3 — Surface texture of ring faces**

<i>R</i> <sub>a</sub> <sup>a</sup>	<i>R</i> <sub>z</sub> <sup>a</sup>
μm	μm
≤ 1,6	≤ 6,3
<sup>a</sup> Defined in EN ISO 4287	

## 8 Marking

The outer surface of each gasket shall be marked with the following information:

- a) the manufacturer's name or trade mark e.g. AAA/BBB;
- b) the gasket identification number prefixed by the letter "R" e.g. R.20 (see 4.4 and Table 1);
- c) the material identification symbol e.g. S316 (see annex A).

Where a material that is given in annex A is used, the material identification symbol given shall be used.

The application of marking shall not damage the contact faces or otherwise harmfully distort the gasket.

Gaskets shall be identified either individually or on the packaging containing the gaskets with the number of this European Standard, i.e. EN 12560-5.

EXAMPLE — EN 12560-5 — AAA/BBB — R.20 — S316.



## Annex A (informative)

### Gasket materials

Typical materials used for the manufacture of metallic ring-joint gaskets are given in Table A.1 together with their recommended maximum hardness values and identification symbols.

The materials used should have a hardness value lower than the flange material to ensure tight joints. It may not be possible, however, for the hardness values of metallic ring-joints to be lower than the flange for some alloys. For example, stainless steel alloy flanges heat-treated for optimum corrosion resistance will have the same range of hardness as the gasket of the same material annealed to minimum hardness.

**Table A.1 — Hardness values and material identification symbols for ring-joint**

Metallic ring-joint gasket material	Material number	Maximum hardness		Identification symbol
		Brinell <sup>a</sup> HB max.	Rockwell <sup>b</sup> HRB max.	
Soft iron	-	90	56	D
Low-carbon steel	-	120	68	S
4 % to 6 % chromium/ 0,5 % molybdenum steel	-	130	72	F5 <sup>c</sup>
X12 Cr13	1.4006	170	86	S410
X5CrNi 18-10	1.4301	160	83	S304
X5CrNiMo 17-12-2	1.4401	160	83	S316
X6CrNiTi 18-10	1.4541	160	83	S321
X6CrNiNb 18-10	1.4550	160	83	S347
X6CrNiMoTi 17-12-2	1.4571	160	83	S316Ti
<sup>a</sup> Brinell hardness is measured with a 3 000 kg load except for soft iron, for which it is measured with a 500 kg load. <sup>b</sup> Rockwell hardness is measured with a 100 kg load and a 1,59 mm diameter ball. <sup>c</sup> F5 identification designates ASTM specification ASTM A182/A182M — 87a chemical composition requirements only.				

---

---

## BSI — British Standards Institution

BSI is the independent national body responsible for preparing British Standards. It presents the UK view on standards in Europe and at the international level. It is incorporated by Royal Charter.

### Revisions

British Standards are updated by amendment or revision. Users of British Standards should make sure that they possess the latest amendments or editions.

It is the constant aim of BSI to improve the quality of our products and services. We would be grateful if anyone finding an inaccuracy or ambiguity while using this British Standard would inform the Secretary of the technical committee responsible, the identity of which can be found on the inside front cover. Tel: 020 8996 9000. Fax: 020 8996 7400.

BSI offers members an individual updating service called PLUS which ensures that subscribers automatically receive the latest editions of standards.

### Buying standards

Orders for all BSI, international and foreign standards publications should be addressed to Customer Services. Tel: 020 8996 9001. Fax: 020 8996 7001. Standards are also available from the BSI website at <http://www.bsi-global.com>.

In response to orders for international standards, it is BSI policy to supply the BSI implementation of those that have been published as British Standards, unless otherwise requested.

### Information on standards

BSI provides a wide range of information on national, European and international standards through its Library and its Technical Help to Exporters Service. Various BSI electronic information services are also available which give details on all its products and services. Contact the Information Centre. Tel: 020 8996 7111. Fax: 020 8996 7048.

Subscribing members of BSI are kept up to date with standards developments and receive substantial discounts on the purchase price of standards. For details of these and other benefits contact Membership Administration. Tel: 020 8996 7002. Fax: 020 8996 7001. Further information about BSI is available on the BSI website at <http://www.bsi-global.com>.

### Copyright

Copyright subsists in all BSI publications. BSI also holds the copyright, in the UK, of the publications of the international standardization bodies. Except as permitted under the Copyright, Designs and Patents Act 1988 no extract may be reproduced, stored in a retrieval system or transmitted in any form or by any means – electronic, photocopying, recording or otherwise – without prior written permission from BSI.

This does not preclude the free use, in the course of implementing the standard, of necessary details such as symbols, and size, type or grade designations. If these details are to be used for any other purpose than implementation then the prior written permission of BSI must be obtained.

If permission is granted, the terms may include royalty payments or a licensing agreement. Details and advice can be obtained from the Copyright Manager. Tel: 020 8996 7070.