

Castors and wheels — Castors and wheels for applications up to 1,1 m/s (4 km/h)

The European Standard EN 12532:1998 has the status of a British Standard

ICS 21.180; 53.060

National foreword

This British Standard is the English language version of EN 12532:1998.

The UK participation in its preparation was entrusted to Technical Committee MHE/7, Industrial trucks — Safety, which has the responsibility to:

- aid enquirers to understand the text;
- present to the responsible European committee any enquiries on the interpretation, or proposals for change, and keep the UK interests informed;
- monitor related international and European developments and promulgate them in the UK.

A list of organizations represented on this committee can be obtained on request to its secretary.

Cross-references

The British Standards which implement international or European publications referred to in this document may be found in the BSI Standards Catalogue under the section entitled “International Standards Correspondence Index”, or by using the “Find” facility of the BSI Standards Electronic Catalogue.

A British Standard does not purport to include all the necessary provisions of a contract. Users of British Standards are responsible for their correct application.

Compliance with a British Standard does not of itself confer immunity from legal obligations.

Summary of pages

This document comprises a front cover, an inside front cover, the EN title page, pages 2 to 12, an inside back cover and a back cover.

This British Standard, having been prepared under the direction of the Engineering Sector Committee, was published under the authority of the Standards Committee and comes into effect on 15 March 1999

© BSI 03-1999

Amendments issued since publication

Amd. No.	Date	Text affected

ICS 21.180; 53.060

Descriptors: wheels, castors, handling equipment, characteristics, product requirements, dimensions, tests, conformity tests, marking

English version

Castors and wheels — Castors and wheels for applications up to 1,1 m/s (4 km/h)

Roues et roulettes — Roues et roulettes pour des applications jusqu'à 1,1 m/s (4 km/h)

Räder und Rollen — Transportgeräterollen bis zu einer Geschwindigkeit von 1,1 m/s (4 km/h)

This European Standard was approved by CEN on 30 August 1998

CEN members are bound to comply with the CEN/CENELEC Internal Regulations which stipulate the conditions for giving this European Standard the status of a national standard without any alteration. Up-to-date lists and bibliographical references concerning such national standards may be obtained on application to the Central Secretariat or to any CEN member.

This European Standard exists in three official versions (English, French, German). A version in any other language made by translation under the responsibility of a CEN member into its own language and notified to the Central Secretariat has the same status as the official versions.

CEN members are the national standards bodies of Austria, Belgium, Czech Republic, Denmark, Finland, France, Germany, Greece, Iceland, Ireland, Italy, Luxembourg, Netherlands, Norway, Portugal, Spain, Sweden, Switzerland and United Kingdom.

CEN

European Committee for Standardization
Comité Européen de Normalisation
Europäisches Komitee für Normung

Central Secretariat: rue de Stassart 36, B-1050 Brussels

Foreword

This European Standard has been prepared by Technical Committee CEN/TC 324, Castors and wheels, the Secretariat of which is held by DIN.

This European Standard shall be given the status of a national standard, either by publication of an identical text or by endorsement, at the latest by March 1999, and conflicting national standards shall be withdrawn at the latest by March 1999.

According to the CEN/CENELEC Internal Regulations, the national standards organizations of the following countries are bound to implement this European Standard: Austria, Belgium, Czech Republic, Denmark, Finland, France, Germany, Greece, Iceland, Ireland, Italy, Luxembourg, Netherlands, Norway, Portugal, Spain, Sweden, Switzerland and the United Kingdom.

Contents

	Page
Foreword	2
1 Scope	3
2 Normative references	3
3 Definitions	3
4 Dimensions and classification	3
4.1 Fixing system	3
4.2 Offset	6
4.3 Wheel	7
4.4 Load capacity	8
5 Requirements	8
5.1 Standard conditions	8
5.2 Initial wheel play	9
5.3 Initial swivel play	9
5.4 Electrical resistance test	10
5.5 Fatigue test for braking and/or locking device	10
5.6 Efficiency check of wheel braking and/or locking device	10
5.7 Efficiency check of swivel braking and/or locking device	10
5.8 Static test	11
5.9 Dynamic test	11
5.10 Efficiency check of wheel braking and/or locking device	11
5.11 Efficiency check of swivel braking and/or locking device	11
5.12 Final wheel play	11
5.13 Final swivel play	11
6 Conformity	12
7 Marking of the product	12
7.1 Product marking	12
7.2 Marking of electrically conductive castor(s) or wheel(s)	12

1 Scope

This European Standard specifies the technical requirements, the appropriate dimensions and the requirements for testing.

This European Standard applies to castors and wheels (which may include accessories) for manually propelled or power towed industrial applications up to 1,1 m/s (4 km/h). This European Standard does not apply to castors and wheels for furniture, swivel chairs, institutional, hospital beds and driven applications

2 Normative references

This European Standard incorporates by dated or undated reference, provisions from other publications. These normative references are cited at the appropriate places in the text and the publications are listed hereafter. For dated references, subsequent amendments to or revisions of any of these publications apply only to this European Standard only when incorporated in it by amendment or revision. For undated references the latest edition of the publication referred to applies.

EN 12526:1998, *Castors and wheels — Vocabulary, recommended symbols and multilingual dictionary.*

EN 12527:1998, *Castors and wheels — Test methods and apparatus.*

ISO 7619, *Rubber — Determination of indentation hardness by means of pocket hardness meters.*

3 Definitions

For the purpose of this European Standard, definitions and recommended symbols of EN 12526:1998 apply.

4 Dimensions and classification

The characteristics of a castor are:

- fixing system (4.1);
- offset (4.2);
- wheel (4.3);
- load capacity (4.4).

4.1 Fixing system

The fixing system includes top plate, solid stem and single bolt fixing.

4.1.1 Top plate

Top plates are identified by classification and include triangular with three fixing holes and rectangular top plates with four fixing holes.

4.1.1.1 Triangular top plate with three fixing holes

The design of the outer profile is left to the manufacturer, provided that it is inscribed in a square of maximum size $A \times A$ as in Table 1 and Figure 1.

The fixing holes are located at the corners of a triangle inscribed in the outer profile. The holes may be oblong and form slots, provided the width of the slot is suitable for a bolt of diameter (G_1) as in Table 1. Table 1 lists the standardized dimensions of the different classes of top plates, showing for each the corresponding wheel diameter (D) where it is applicable.

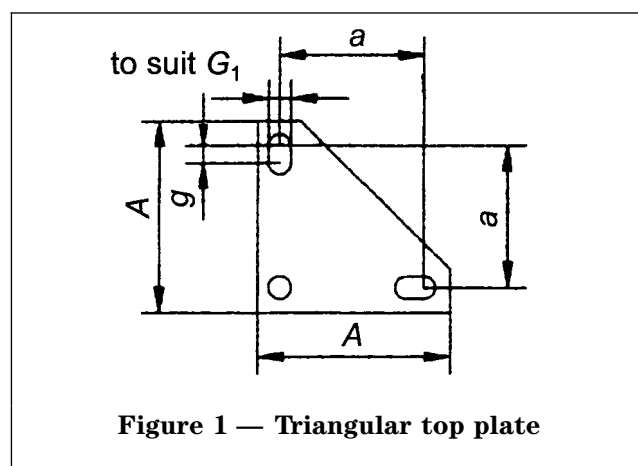

Figure 1 — Triangular top plate

4.1.1.2 Rectangular top plate with four fixing holes

The design of the outer profile is left to the manufacturer, provided that it is inscribed in a rectangle of maximum size $A \times B$ as in Table 2 and Figure 2.

The fixing holes are located at the corners of a rectangle inscribed in the outer profile. The holes may be oblong and form slots, provided the width of the slot is suitable for bolts of diameter (G_1) as in Table 2. Table 2 lists the standardized dimensions of the different classes of top plates, showing for each the corresponding wheel diameter (D) where it is applicable.

Table 1 — Triangular top plate

Dimensions in millimetres

Class	Maximum plate dimension ($A \times A$)	Bolt hole spacing ($a \times a$)	Bolt diameter (G_1)	Minimum distance of slotted hole centres (g)	Corresponding wheel diameter (D)
T41	75 × 75	55	6	5	50 63 75/80 100
T42	115 × 115	80	8	11	50 63 75/80 100 125
T43	145 × 145	105	8	11	63 75/80 100 125 150/160 200
T44	145 × 145	105	10	9	63 75/80 100 125 150/160 200
T45	175 × 175	140	10	17	125 150/160 200 250 300
T46	175 × 175	140	12	14	125 150/160 200 250 300

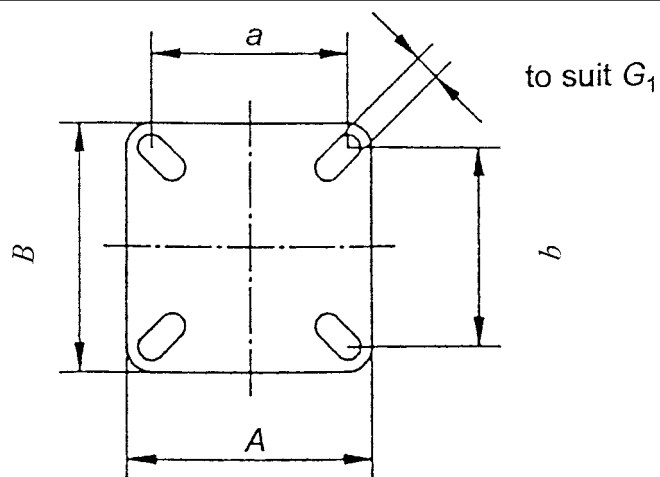

Figure 2 — Rectangular top plate

Table 2 — Rectangular top plate

Class	Maximum plate dimensions (A × B)	Bolt hole spacing (a × b)	Bolt diameter (G ₁)	Dimensions in millimetres
				Corresponding wheel diameter (D)
R41	75 × 60	55 × 40	6	50 63
R42	115 × 85	80 × 60	8	50 63 75/80 100 125 150/160
R43	145 × 110	105 × 80	10 or 12	75/80 100 125 150/160 200 250
R44	175 × 140	140 × 105	10 or 12	125 150/160 200 250 300
R45	200 × 160	160 × 120	12 or 14	200 250 300 350 400
R46	255 × 205	210 × 160	14 or 16	200 250 300 350 400 500

4.1.2 Solid stem

Table 3 specifies the solid stem diameters corresponding to the wheel diameter. The length of the solid stem must be at least 1,5 times its diameter.

In those cases where the solid stem is supplied with a cross hole for fixing to a tubular structure, the axis of such hole shall be at a 19 mm ± 0,25 mm (distance measured from the collar of the stem) threaded to M₈ (as in Figure 3a) or bored to 8 mm + 0,3 mm (as in Figure 3b).

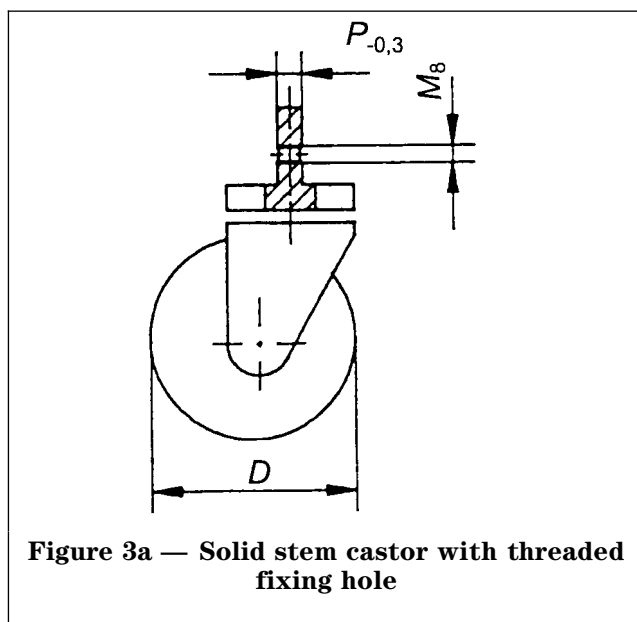

Figure 3a — Solid stem castor with threaded fixing hole

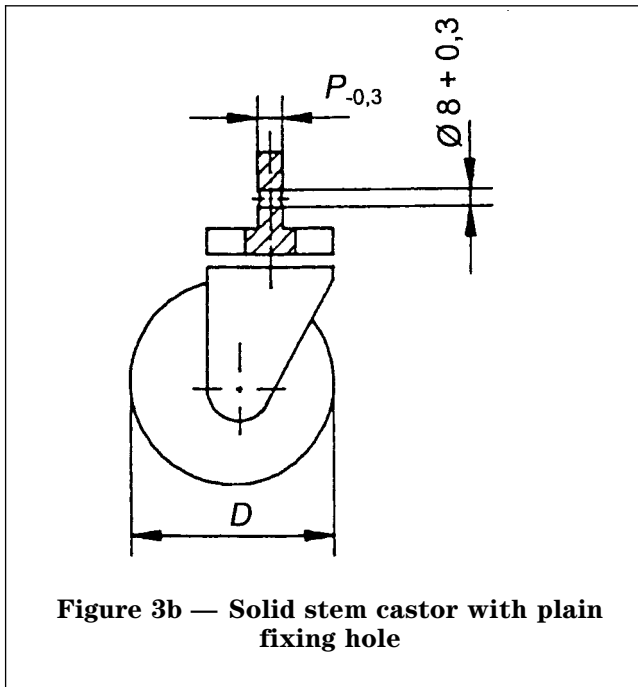

Figure 3b — Solid stem castor with plain fixing hole

Table 3 — Solid stem diameter

Dimensions in millimetres

Wheel diameter (<i>D</i>)	Stem dimensions	
	Diameter (<i>P</i>)	Tolerance
50	20	0 -0,3
	22	
63	20	
	22	
75/80	20	
	22	
100	20	
	22	
125	22	
	27	
150/160	22	
	27	
200	27	
250	27	
300	27	

4.1.3 Single bolt fixing

Table 4 specifies the bolt diameters (G_2) for single bolt fixing corresponding to the wheel diameter (D).

Table 4 — Bolt diameters for single bolt fixing

Dimensions in millimetres

Wheel diameter (<i>D</i>)	Bolt diameter (G_2)
50	8
	10
63	8
	10
75/80	10
	12
100	10
	12
125	10
	12
150/160	12
	16
	20
200	12
	16
	20
250	16
	20
300	20

4.2 Offset

Table 5 specifies the minimum and maximum offset values (F) for the swivel castors, corresponding to the wheel diameter (D), as in Figure 4.

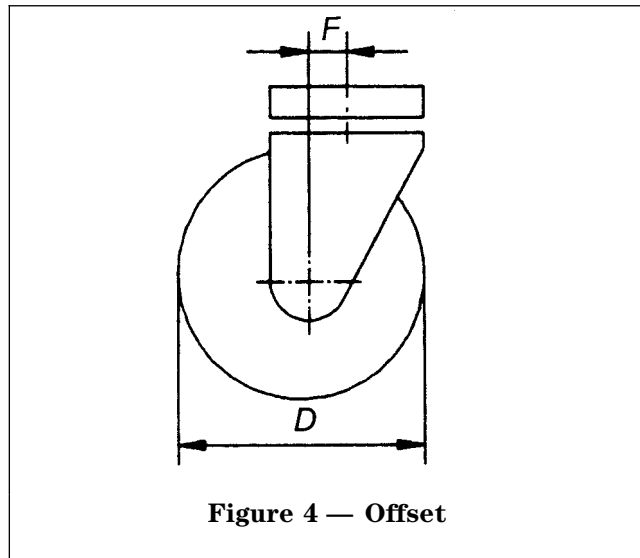

Figure 4 — Offset

Table 5 — Offset

Dimensions in millimetres

Wheel diameter (<i>D</i>)	Offset (<i>F</i>)	
	Minimum	Maximum
50	10	30
63	12	40
75/80	15	50
100	20	60
125	25	70
150/160	30	85
200	40	100
250	50	115
300	60	130
350	70	140
400	80	150
500	100	170

NOTE For shock absorbing castors the offset may vary from the dimensions stated.

4.3 Wheel

The characteristics of a wheel are:

- diameter (see Table 6);
- hub width (see Table 6);
- bore diameter (see Table 6);
- load capacity (4.4).

The characteristics of the wheel are illustrated in Figure 5 and the hub width (T_1) and bore diameter (d) corresponding to each wheel diameter (D) are listed in Table 6. Wheels are not restricted to these hub widths and bores when used in castors.

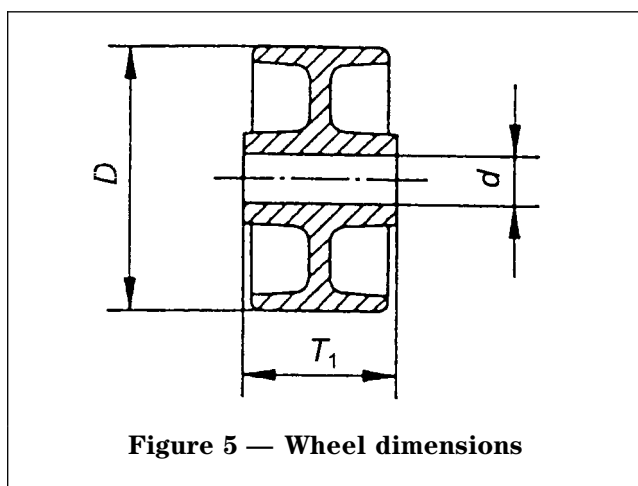

Figure 5 — Wheel dimensions

Table 6 — Wheel dimensions

Dimensions in millimetres

Wheel diameter (<i>D</i>)	Hub width (T_1)	Bore diameters* (<i>d</i>)
50	30	8 10
63	30	8 10
75/80	30	8 10 12 15
	45/50	12 15
100	30	8 10 12 15
	45/50	12 15 20
125	45/50	12 15 20
	60	20 25
150/160	45/50	20 25
	60	20 25 30
200	45/50	20 25
	60	20 25 30
	75	20 25 30 35 40
	90	25 30 35 40
	120	30 35 40 50

Table 6 — Wheel dimensions (*continued*)

Dimensions in millimetres

Wheel diameter (<i>D</i>)	Hub width (<i>T</i> ₁)	Bore diameters* (<i>d</i>)
250	60	25 30
	75/90	25 30 35 40
	120	30 35 40 50
300	60	25 30 35
	75	25 30 35 40
	90	25 30 35 40 50
	120	35 40 50
350	90	25 30 35 40 50
	120	35 40 50
400	90	25 30 35 40 50
	120	35 40 50
500	90	25 30 35 40 50
	120	35 40 50

* The user of a wheel must verify the mechanical strength of axle components (bolts, nuts, bushes, spacers etc.).
The above bores refer to the nominal diameter of the axle.

4.3.1 Wheel diameter tolerance

The tolerance on the wheel diameter (*D*) is $\pm 1\%$.

4.3.2 Hub width tolerance

The tolerance on the hub width (*T*₁) is ${}^0_{-2}\%$ with a minimum value of 1 mm.

4.4 Load capacity

Maximum load, in N, which can be carried by a wheel or a castor so as to fully comply to the required acceptance criteria.

5 Requirements

Testing requirements for castors and wheels are listed below. Test procedures and apparatus are defined in EN 12527:1998.

5.1 Standard conditions

5.1.1 Environmental conditions

Tests have to be carried out at a temperature between 15 °C and 28 °C. During the 24 h prior to the test the sample(s) shall remain at the above temperature, in an environment with a relative humidity between 40 % and 70 %.

Sample(s) shall not be artificially cooled during testing.

5.1.2 Test sequence

Tests, where applicable, shall be carried out in the sequence as listed in Table 7.

Table 7 — Test sequence for castor and wheel types

Reference	Test sequence	Castors and wheel types	Test procedures reference
5.2	Initial wheel play	All castors	4.2
5.3	Initial swivel play	Swivel castors with or without accessories	4.3
5.4	Electrical resistance	Castors and wheels electrically conductive	4.4
5.5	Fatigue test for braking and/or locking devices	Castors with a: — wheel locking/braking device; — directional locking device; — total locking/braking device; — central locking/braking device. If device is operated by means of threaded mechanism this test will not be applicable.	4.5
5.6	Efficiency check of wheel braking and/or locking device	Castors with a: — wheel locking/braking device; — total locking/braking device; — central locking/braking device.	4.6
5.7	Efficiency check of swivel braking and/or locking device	Castors with a: — directional locking/braking device; — total locking/braking device; — central locking/braking device.	4.7
5.8	Static test	Test is not required	4.9
5.9	Dynamic test	All	4.8
5.10	Efficiency check of wheel braking and/or locking device	Castors with a: — wheel locking/braking device; — total locking/braking device; — central locking/braking device.	4.6
5.11	Efficiency check of swivel braking and/or locking device	Castors with a: — directional locking/braking device; — total locking/braking device; — central locking/braking device.	4.7
5.12	Final wheel play	All castors	4.2
5.13	Final swivel play	Swivel castors with or without accessories	4.3

5.2 Initial wheel play

5.2.1 Test objectives, apparatus and procedures

Detailed in 4.2 of EN 12527:1998.

5.2.2 Acceptance criteria

The measured initial wheel play shall not exceed the value (W_1).

Symbol	Value	Description
D	variable	wheel diameter
W_1	1 % of D	maximum initial wheel play

5.3 Initial swivel play

5.3.1 Test objectives, apparatus and procedures

Detailed in 4.3 of EN 12527:1998.

5.3.2 Tolerances

The tolerances are:

- of the swivel play: lever of 200 mm use to measure the play: ± 2 mm;
- angle of rotation of swivelling by 90° : $\pm 5^\circ$.

5.3.3 Acceptance criteria

The measured initial swivel play shall not exceed the value (S_1).

Symbol	Value	Description
S_1	4 mm	maximum initial swivel play

5.4 Electrical resistance test

5.4.1 Test objectives, apparatus and procedures

Detailed in 4.4 of EN 12527:1998.

5.4.2 Test values

The test values are listed below.

Symbol	Value	Description
L_1	variable	load capacity
L_{17}	10 % of L_1	test load
R	variable	measured electrical resistance

5.4.3 Tolerances

The tolerance is:

Symbol	Tolerance	
	Unit	Acceptable
L_1	N	$\begin{matrix} +2 \\ 0 \end{matrix}$ %
L_{17}	N	$\begin{matrix} +2 \\ 0 \end{matrix}$ %

5.4.4 Acceptance criteria

The resistance R of the sample tested shall be:

- conductive castor(s) or wheel(s): $R \leq 10^4 \Omega$;
- antistatic castor(s) or wheel(s): $10^5 \leq R \leq 10^7 \Omega$.

5.5 Fatigue test for braking and/or locking device

5.5.1 Test objectives, apparatus and procedures

Detailed in 4.5 of EN 12527:1998.

5.5.2 Test values

The test values are listed below.

Symbol	Value	Description
E_1	5 000	number of locking actions
E_2	10	cycles per min
L_1	not required in this test	load capacity as test load

5.5.3 Tolerances

The tolerances are:

Symbol	Tolerance	
	Unit	Acceptable
E_1	number	$\begin{matrix} +1 \\ 0 \end{matrix}$ %
E_2	cycles/min	$\begin{matrix} 0 \\ -2 \end{matrix}$
L_1	N	$\begin{matrix} +2 \\ 0 \end{matrix}$ %

5.5.4 Acceptance criteria

The test is passed if there is no wear and/or permanent deformation which adversely affects the performance of the sample.

5.6 Efficiency check of wheel braking and/or locking device

5.6.1 Test objectives, apparatus and procedures

Detailed in 4.6 of EN 12527:1998.

5.6.2 Test values

The test values are listed below.

Symbol	Value	Description
L_1	variable	load capacity as test load
K_1	15 % of L_1	horizontal tractive force

5.6.3 Tolerances

The tolerances are:

Symbol	Tolerance	
	Unit	Acceptable
L_1	N	$\begin{matrix} +2 \\ 0 \end{matrix}$ %
K_1	N	$\begin{matrix} +4 \\ 0 \end{matrix}$ %

The tolerance of the time of application of force K_1 (10 s) is: $\begin{matrix} +2 \\ 0 \end{matrix}$ s.

5.6.4 Acceptance criteria

No revolving movement of the wheel around its axis is allowed when the force K_1 is applied.

5.7 Efficiency check of swivel braking and/or locking device

5.7.1 Test objectives, apparatus and procedures

Detailed in 4.7 of EN 12527:1998.

5.7.2 Test values

The test values are listed below.

Symbol	Value	Description
L_1	variable	load capacity as test load
K_2	15 % of L_1	horizontal tractive force

5.7.3 Tolerances

The tolerances are:

Symbol	Tolerance	
	Unit	Acceptable
L_1	N	$\begin{matrix} +2 \\ 0 \end{matrix}$ %
K_2	N	$\begin{matrix} +4 \\ 0 \end{matrix}$ %

The tolerance of the time of application of force K_2 (10 s) is: $\begin{matrix} +2 \\ 0 \end{matrix}$ s.

5.7.4 Acceptance criteria

No swivelling movement is detected during the second application of the force K_2 .

5.8 Static test

This test is not required.

5.9 Dynamic test

5.9.1 Test objectives, apparatus and procedures

Detailed in 4.8 of EN 12527:1998.

5.9.2 Test values

The test values are listed below.

Symbol	Value	Description
L_1	variable	load capacity as test load*
v_1	1,1 m/s (4 km/h)	average speed
v_2	1,1 m/s (4 km/h)	speed at impact
h_1	height of obstacles for wheels with: — tread hardness $\geq 90^\circ$ Shore A: 2,5 % of D; — tread hardness $< 90^\circ$ Shore A: 5,0 % of D.	height of obstacles
c	1 to 3 m	distance between obstacles
n	500	number of obstacles
r_1	15 000	number of wheel revolutions
z_1	3 min	running period
z_2	max. 1 min	pause period
D	variable	wheel diameter

* NOTE For load capacities above 10 000 N a simulated load applied, mechanically, hydraulically or pneumatically is acceptable provided that it is previously verified. A real load is preferred.

5.9.3 Tolerances

The tolerances are:

Symbol	Tolerance	
	Unit	Acceptable
L_1	N	$\begin{matrix} +2 \\ 0 \end{matrix}$ %
v_1	m/s	$\begin{matrix} +5 \\ 0 \end{matrix}$ %
v_2	m/s	$\begin{matrix} +5 \\ 0 \end{matrix}$ %
h_1	mm	$\begin{matrix} 0 \\ -5 \end{matrix}$ %
n		$\begin{matrix} +1 \\ 0 \end{matrix}$ %
r_1		$\begin{matrix} +1 \\ 0 \end{matrix}$ %
z_1	min	± 10 s
z_2	min	± 10 s

The tolerances are:

- of the obstacle width (100 mm): ± 2 mm;
- of the angle of obstacles to line of motion of 45° : $\pm 3^\circ$.

5.9.4 Acceptance criteria

The test is passed if there is no permanent deformation of the sample, which adversely affects its performance.

5.10 Efficiency check of wheel braking and/or locking device

Repeat test in 5.6.

5.11 Efficiency check of swivel braking and/or locking device

Repeat test in 5.7.

5.12 Final wheel play

5.12.1 Test objectives, apparatus and procedures

Detailed in 4.2 of EN 12527:1998.

5.12.2 Acceptance criteria

The wheel wear play shall not exceed the value (W_2).

Symbol	Value	Description
D	variable	wheel diameter
W_2	0,8 % of D	maximum wheel wear play

5.13 Final swivel play

5.13.1 Test objectives, apparatus and procedures

Detailed in 4.3 of EN 12527:1998.

5.13.2 Tolerances

The tolerances are:

- of the swivel play: lever of 200 mm use to measure the play: ± 2 mm;
- angle of rotation of swivelling by 90° : $\pm 5^\circ$.

5.13.3 Acceptance criteria

The swivel wear play shall not exceed the value (S_2).

Symbol	Value	Description
S_2	4 mm	maximum swivel wear play

6 Conformity

The manufacturer declares on request by a certificate of conformity that the castors or wheels are in accordance with the requirements as stated in this document.

The type of test machine shall be stated in the conformity document.

7 Marking of the product

7.1 Product marking

All the products shall be permanently and visibly marked with a name and/or trade mark of the manufacturer.

7.2 Marking of electrically conductive castor(s) or wheel(s)

All products shall bear on their outer surface a clearly visible yellow mark, and where appropriate and possible should include the word "antistatic".

BSI — British Standards Institution

BSI is the independent national body responsible for preparing British Standards. It presents the UK view on standards in Europe and at the international level. It is incorporated by Royal Charter.

Revisions

British Standards are updated by amendment or revision. Users of British Standards should make sure that they possess the latest amendments or editions.

It is the constant aim of BSI to improve the quality of our products and services. We would be grateful if anyone finding an inaccuracy or ambiguity while using this British Standard would inform the Secretary of the technical committee responsible, the identity of which can be found on the inside front cover. Tel: 020 8996 9000. Fax: 020 8996 7400.

BSI offers members an individual updating service called PLUS which ensures that subscribers automatically receive the latest editions of standards.

Buying standards

Orders for all BSI, international and foreign standards publications should be addressed to Customer Services. Tel: 020 8996 9001. Fax: 020 8996 7001.

In response to orders for international standards, it is BSI policy to supply the BSI implementation of those that have been published as British Standards, unless otherwise requested.

Information on standards

BSI provides a wide range of information on national, European and international standards through its Library and its Technical Help to Exporters Service. Various BSI electronic information services are also available which give details on all its products and services. Contact the Information Centre. Tel: 020 8996 7111. Fax: 020 8996 7048.

Subscribing members of BSI are kept up to date with standards developments and receive substantial discounts on the purchase price of standards. For details of these and other benefits contact Membership Administration. Tel: 020 8996 7002. Fax: 020 8996 7001.

Copyright

Copyright subsists in all BSI publications. BSI also holds the copyright, in the UK, of the publications of the international standardization bodies. Except as permitted under the Copyright, Designs and Patents Act 1988 no extract may be reproduced, stored in a retrieval system or transmitted in any form or by any means – electronic, photocopying, recording or otherwise – without prior written permission from BSI.

This does not preclude the free use, in the course of implementing the standard, of necessary details such as symbols, and size, type or grade designations. If these details are to be used for any other purpose than implementation then the prior written permission of BSI must be obtained.

If permission is granted, the terms may include royalty payments or a licensing agreement. Details and advice can be obtained from the Copyright Manager. Tel: 020 8996 7070.