

BS EN 12491:2015



BSI Standards Publication

# Paragliding equipment — Emergency parachutes — Safety requirements and test methods

**bsi.**

...making excellence a habit.™

**National foreword**

This British Standard is the UK implementation of EN 12491:2015. It supersedes BS EN 12491:2001 which is withdrawn.

The UK participation in its preparation was entrusted to Technical Committee SW/136/-/6, Sports, Playground and other Recreational Equipment - Paragliding.

A list of organizations represented on this committee can be obtained on request to its secretary.

This publication does not purport to include all the necessary provisions of a contract. Users are responsible for its correct application.

© The British Standards Institution 2015.  
Published by BSI Standards Limited 2015

ISBN 978 0 580 84799 8

ICS 97.220.40

**Compliance with a British Standard cannot confer immunity from legal obligations.**

This British Standard was published under the authority of the Standards Policy and Strategy Committee on 30 November 2015.

**Amendments/corrigenda issued since publication**

| Date | Text affected |
|------|---------------|
|------|---------------|

---

EUROPEAN STANDARD

**EN 12491**

NORME EUROPÉENNE

EUROPÄISCHE NORM

November 2015

ICS 97.220.40

Supersedes EN 12491:2001

English Version

## Paragliding equipment - Emergency parachutes - Safety requirements and test methods

Équipement pour le parapente - Parachute de secours -  
Exigences de sécurité et méthodes d'essai

Ausrüstung für das Gleitschirmfliegen -  
Rettungsfallschirme - Sicherheitstechnische  
Anforderungen und Prüfverfahren

This European Standard was approved by CEN on 26 September 2015.

CEN members are bound to comply with the CEN/CENELEC Internal Regulations which stipulate the conditions for giving this European Standard the status of a national standard without any alteration. Up-to-date lists and bibliographical references concerning such national standards may be obtained on application to the CEN-CENELEC Management Centre or to any CEN member.

This European Standard exists in three official versions (English, French, German). A version in any other language made by translation under the responsibility of a CEN member into its own language and notified to the CEN-CENELEC Management Centre has the same status as the official versions.

CEN members are the national standards bodies of Austria, Belgium, Bulgaria, Croatia, Cyprus, Czech Republic, Denmark, Estonia, Finland, Former Yugoslav Republic of Macedonia, France, Germany, Greece, Hungary, Iceland, Ireland, Italy, Latvia, Lithuania, Luxembourg, Malta, Netherlands, Norway, Poland, Portugal, Romania, Slovakia, Slovenia, Spain, Sweden, Switzerland, Turkey and United Kingdom.



EUROPEAN COMMITTEE FOR STANDARDIZATION  
COMITÉ EUROPÉEN DE NORMALISATION  
EUROPÄISCHES KOMITEE FÜR NORMUNG

**CEN-CENELEC Management Centre: Avenue Marnix 17, B-1000 Brussels**

| <b>Contents</b>  |   | <b>Page</b> |
|--|---|-------------|
| <b>European foreword</b> .....   |   | <b>3</b>    |
| <b>Introduction</b> .....  |   | <b>4</b>    |
| <b>1</b>   | <b>Scope</b> .....  | <b>5</b>    |
| <b>2</b>   | <b>Normative references</b> .....                             | <b>5</b>    |
| <b>3</b>   | <b>Terms and definitions</b> .....                            | <b>5</b>    |
| <b>4</b>   | <b>Safety requirements</b> .....                              | <b>8</b>    |
| <b>4.1</b>   | <b>Deployment system</b> .....                                | <b>8</b>    |
| <b>4.2</b>   | <b>Speed of opening</b> .....                                 | <b>8</b>    |
| <b>4.3</b>   | <b>Descent rate and stability</b> .....                       | <b>8</b>    |
| <b>4.3.1</b>   | <b>Unsteerable parachute</b> .....                            | <b>8</b>    |
| <b>4.3.2</b>   | <b>Steerable parachute</b> .....                              | <b>8</b>    |
| <b>4.4</b>   | <b>Strength</b> .....   | <b>9</b>    |
| <b>4.5</b>   | <b>Additional requirements for steerable parachutes</b> ..... | <b>9</b>    |
| <b>5</b>   | <b>Test methods</b> .....                                     | <b>9</b>    |
| <b>5.1</b>   | <b>Test apparatus</b> .....                                   | <b>9</b>    |
| <b>5.2</b>   | <b>Test conditions</b> .....                                  | <b>9</b>    |
| <b>5.3</b>   | <b>Procedure</b> .....  | <b>9</b>    |
| <b>5.3.1</b>   | <b>General</b> .....  | <b>9</b>    |
| <b>5.3.2</b>   | <b>Deployment system strength test</b> .....                  | <b>10</b>   |
| <b>5.3.3</b>   | <b>Speed of opening test</b> .....                            | <b>10</b>   |
| <b>5.3.4</b>   | <b>Descent rate and stability test</b> .....                  | <b>10</b>   |
| <b>5.3.5</b>   | <b>Strength test</b> .....                                    | <b>10</b>   |
| <b>5.3.6</b>   | <b>Additional tests for steerable parachutes</b> .....        | <b>11</b>   |
| <b>6</b>   | <b>Test files</b> .....                                       | <b>11</b>   |
| <b>6.1</b>   | <b>Test file information</b> .....                            | <b>11</b>   |
| <b>6.2</b>   | <b>Items accompanying the test files</b> .....                | <b>12</b>   |
| <b>7</b>   | <b>Manufacturing record</b> .....                             | <b>12</b>   |
| <b>8</b>   | <b>User's manual</b> .....                                    | <b>12</b>   |
| <b>9</b>   | <b>Marking</b> .....  | <b>14</b>   |
| <b>Annex A (informative) Example of marking label</b> .....  |   | <b>15</b>   |
| <b>Annex B (normative) Formula to be used for correcting the test mass for differences from ICAO standard atmosphere</b> ..... |   | <b>16</b>   |
| <b>Annex C (informative) Example drop test device</b> .....  |   | <b>17</b>   |

## European foreword

This document (EN 12491:2015) has been prepared by Technical Committee CEN/TC 136 “Sports, playground and other recreational facilities and equipment”, the secretariat of which is held by DIN.

This European Standard shall be given the status of a national standard, either by publication of an identical text or by endorsement, at the latest by May 2016, and conflicting national standards shall be withdrawn at the latest by May 2016.

Attention is drawn to the possibility that some of the elements of this document may be the subject of patent rights. CEN [and/or CENELEC] shall not be held responsible for identifying any or all such patent rights.

This document supersedes EN 12491:2001.

This standard is one of a package of standards on equipment for paragliding as follows:

- EN 926-1, *Paragliding equipment — Paragliders — Part 1: Requirements and test methods for structural strength*;
- EN 926-2, *Paragliding equipment — Paragliders — Part 2: Requirements and test methods for classifying flight safety characteristics*;
- EN 1651, *Paragliding equipment — Harnesses — Safety requirements and strength tests*;
- EN 12491, *Paragliding equipment — Emergency parachutes — Safety requirements and test methods*.

In comparison with the previous edition EN 12491:2001, the following significant changes have been made:

- a) editorial revision;
- b) introduction of characteristics and requirements for steerable parachutes;
- c) update of test files information and items accompanying the test file;
- d) update of user manual content.

According to the CEN/CENELEC Internal Regulations, the national standards organizations of the following countries are bound to implement this European Standard: Austria, Belgium, Bulgaria, Croatia, Cyprus, Czech Republic, Denmark, Estonia, Finland, Former Yugoslav Republic of Macedonia, France, Germany, Greece, Hungary, Iceland, Ireland, Italy, Latvia, Lithuania, Luxembourg, Malta, Netherlands, Norway, Poland, Portugal, Romania, Slovakia, Slovenia, Spain, Sweden, Switzerland, Turkey and the United Kingdom.

## **Introduction**

The aim of this European Standard is to enhance paraglider pilots' safety by testing to confirm that emergency parachutes are likely to be able to perform their intended function.

The tests do not include any compatibility tests with alternative inner containers.

Emergency parachutes shall be supplied by the manufacturer for testing complete with attachments suitable for connection to an EN 1651 paragliding harness, and parachutes will be tested as if they were so connected. These connections are made in such a way, and/or using resistant material, so that they are not subject to friction or heat failure due to the tightening or slipping possible under shock loads. Any metal link is installed in such a way as to minimize any risk of injury to the pilot in an emergency deployment, and to ensure that it will be loaded in the direction of its maximum strength.

## 1 Scope

This European Standard is applicable to emergency parachutes deployed by the action of the pilot without any other assistance (mechanical or pyrotechnic), intended for use with single-seater or two-seater paragliders.

## 2 Normative references

The following documents, in whole or in part, are normatively referenced in this document and are indispensable for its application. For dated references, only the edition cited applies. For undated references, the latest edition of the referenced document (including any amendments) applies.

EN 926-1, *Paragliding equipment — Paragliders — Part 1: Requirements and test methods for structural strength*

EN 1651, *Paragliding equipment — Harnesses — Safety requirements and strength tests*

## 3 Terms and definitions

For the purposes of this document, the following terms and definitions apply.

### 3.1

#### **paraglider**

ultra light glider with no primary rigid structure, for which take-off and landing are on foot, with the pilot (and potentially one passenger) carried in a harness (or harnesses) connected to the wing

### 3.2

#### **emergency parachute**

emergency device intended to slow the descent of a paraglider pilot in the event of an incident in flight, which is deployed by the pilot by an intentional manual action

Note 1 to entry: This may be unsteered or steerable.

### 3.3

#### **riser**

lowest part of the parachute system, which is connected to the harness

Note 1 to entry: Examples of risers are presented in Figure 1 and Figure 2.

### 3.4

#### **suspension lines**

multiple cords connecting the emergency parachute canopy to the riser(s)

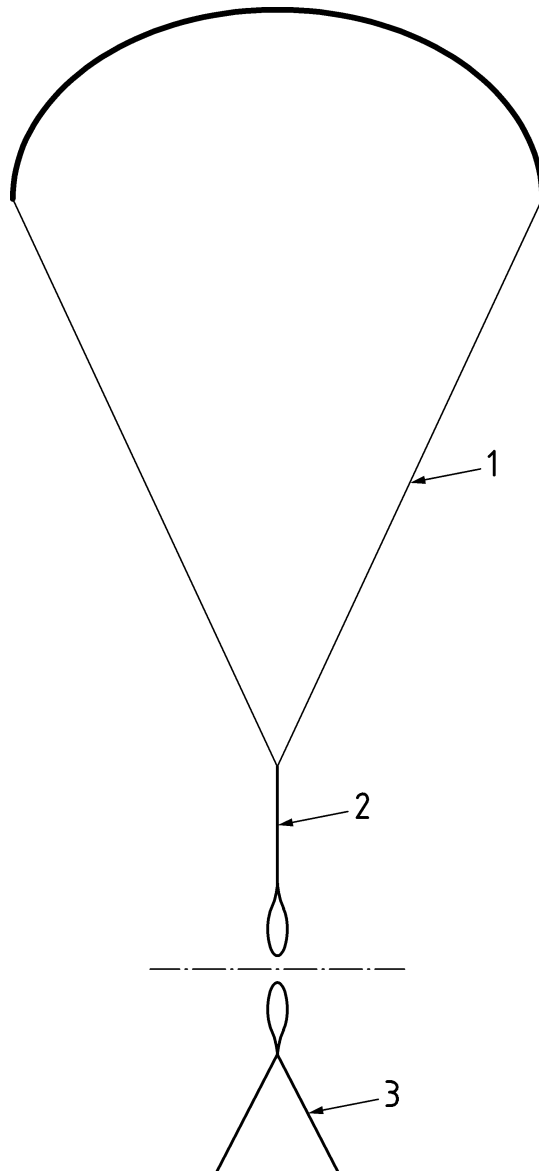

**Key**

- 1 suspension lines
- 2 riser
- 3 paragliding harness emergency parachute bridle

**Figure 1 — Example of unsteerable emergency parachute components**



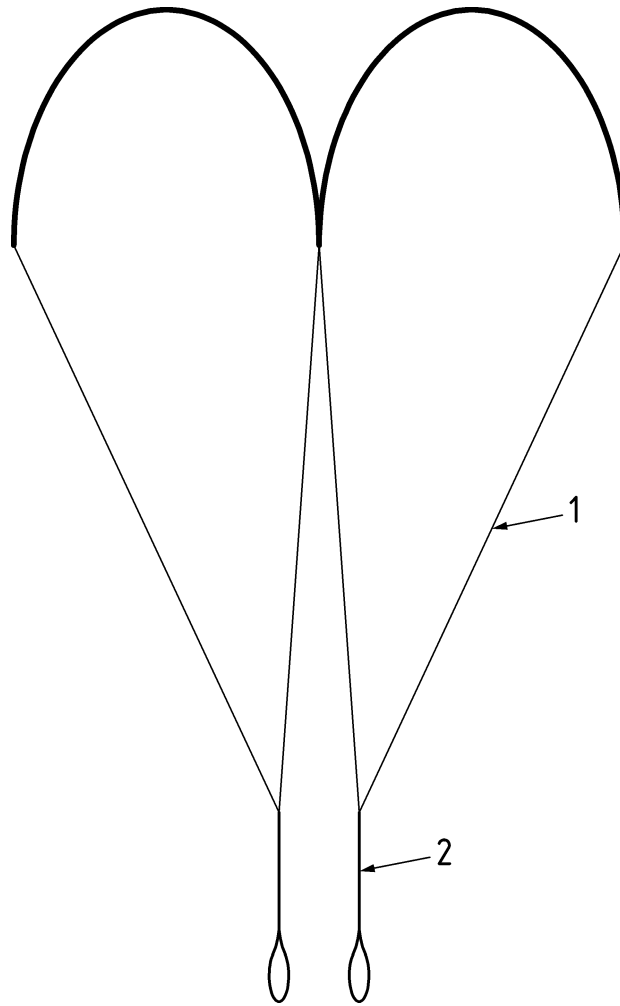

**Key**

- 1 suspension lines
- 2 risers

**Figure 2 — Example of steerable emergency parachute components**

**3.5**

**outer container**

external container, either supplied as part of the harness, or by the parachute manufacturer for attachment to a harness

**3.6**

**inner container or deployment bag**

container of the folded emergency parachute

**3.7**

**deployment system**

inner container and either the handle attachment point(s) or handle assembly

**3.8**

**emergency parachute system**

emergency parachute combined with its deployment system

### **3.9 shock absorbing device**

any special component fitted within the parachute system to reduce the opening shock forces on the pilot and parachute in high speed deployments

Note 1 to entry: If fitted they should be clearly identified, by label and colour, and maintenance (and replacement) instructions included in the user's manual.

### **3.10 drop test device**

rigid test object, of adjustable mass, with one rigid attachment point for the emergency parachute

### **3.11 payload**

total weight in flight minus weight of paraglider

### **3.12 steerable parachute**

emergency parachute fitted with controls for steering and landing flare

## **4 Safety requirements**

### **4.1 Deployment system**

When tested in accordance with 5.3.2, there shall be no failure of any component of the deployment system.

### **4.2 Speed of opening**

When tested in accordance with 5.3.3, in both tests the time interval shall be less than 4 s.

### **4.3 Descent rate and stability**

#### **4.3.1 Unsteerable parachute**

When tested twice in accordance with 5.3.4:

- a) in each test the average rate of descent (corrected to ICAO standard atmosphere, see Annex B) shall be less than 5,5 m/s;
- b) in each test the average horizontal airspeed (corrected to ICAO standard atmosphere, see Annex B) shall be less than the average rate of descent (glide ratio less than 1:1);
- c) in each test any oscillations shall reduce;
- d) the emergency parachute system shall not suffer any permanent deformation (except in the case of any shock absorbing device which is intended to be replaced after any deployment).

#### **4.3.2 Steerable parachute**

When tested twice in accordance with 5.3.4:

- a) in each test the average rate of descent (corrected to ICAO standard atmosphere, see Annex B) shall be less than 4 m/s;

- b) in each test the average horizontal airspeed (corrected to ICAO standard atmosphere, see Annex B) shall be less than 5,5 m/s;
- c) in each test any oscillations shall reduce;
- d) the emergency parachute system shall not suffer any permanent deformation (except in the case of any shock absorbing device which is intended to be replaced after any deployment).

#### **4.4 Strength**

When tested in accordance with 5.3.5.1 or 5.3.5.2 (at the discretion of the manufacturer):

- a) in both tests the emergency parachute shall open fully and absorb the opening shock;
- b) in both tests the emergency parachute system shall not suffer any significant failure of the primary structure (except in the case of any shock absorbing device which is intended to be replaced after any deployment);
- c) in the case of a steerable parachute, in both tests, the controls shall remain locked.

#### **4.5 Additional requirements for steerable parachutes**

When tested in accordance with 5.3.6, using the emergency parachute's controls as described in the user's manual, the parachute shall not exhibit any abnormal flying characteristics.

### **5 Test methods**

#### **5.1 Test apparatus**

- a) Meteorological measuring equipment to check wind speed, temperature, pressure and humidity;
- b) zoom lens video camera and video recorder capable of timed single frame analysis;
- c) drop test device (see Annex C for example design);
- d) equipment to measure parachute descent rates (see test 5.3.4).

#### **5.2 Test conditions**

- a) Wind shall be less than 10 km/h within the test perimeter;
- b) no thermals and/or air movements due to aircraft within the test perimeter;
- c) relative humidity shall be between 40 % and 80 %.

#### **5.3 Procedure**

##### **5.3.1 General**

The parachute shall be presented for testing with a declared maximum payload,  $m_{dec}$ .

In tests 5.3.4 and 5.3.5, the parachute is tested with a corrected payload  $m_{corr}$ . This corrected payload shall be calculated from the declared maximum payload and the prevailing atmospheric conditions using the formula shown in Annex B.

All the tests shall be recorded on video for analysis of test results. A copy of all video recordings shall be made available to the manufacturer as an aid to research and development.

Where a steerable parachute is presented for testing, it shall be tested with any controls in their default (locked) condition (other than for 5.3.6). In this condition, it shall meet all the test requirements.

### **5.3.2 Deployment system strength test**

With the emergency parachute installed in its deployment system, the parachute container shall be restrained and a load of 700 N applied to the deployment handle attachment point(s) or handle assembly.

### **5.3.3 Speed of opening test**

With the riser(s) secured to the moving vehicle, and at a horizontal airspeed of 10 m/s ( $\pm 1$  m/s) and a vertical airspeed of less than 1,5 m/s, the parachute (packed in the inner container according to the user's manual instructions) is free dropped.

The time is measured from the instant of free drop until a load of 200 N is sustained (this could be measured with the aid of 200 N weak link). The inner container shall have opened prior to reaching the load of 200 N.

The test is carried out twice (this may be with the same parachute or with an identical item).

This test could be carried out from a moving vehicle or aircraft.

### **5.3.4 Descent rate and stability test**

The parachute's riser(s) shall be connected to the drop test device's anchor points (or to a pilot ballasted to the required weight) using the connector specified by the parachute manufacturer to connect to both EN 1651 harness emergency parachute attachment points.

In order to introduce an initial pendulum oscillation, the parachute is opened while the test mass is at a horizontal airspeed of 10 m/s ( $\pm 1$  m/s) and a vertical airspeed of less than 1,5 m/s.

From the point of opening there shall be no wing or other drag device acting on the test mass. (If this test is done from a paraglider in flight, this means that the paraglider shall be released as the parachute begins to open).

The stability of the parachute is visually assessed (with the aid of a telephoto video recording) from the time of opening to contact with the ground.

After a minimum of 125 m of descent, the average rate of descent is measured over 40 m of descent.

Any method of direct, accurate and repeatable measurement of rate of descent can be used.

**EXAMPLE** This could be by the use of a calibrated solid state recording barograph, with a recording rate of at least five samples per second, attached to the drop test device. An alternative could be that the rate of descent might be measured by the use of a 40 m cord with weighted end, which is attached to the bottom of the drop test device. The speed in this case being calculated from the time interval between the instant of ground impact of the weighted end, to ground impact of the drop test device.

The average horizontal airspeed (or glide ratio) is measured during the descent, using any convenient methodology. The test is carried out twice (this may be with the same parachute or with an identical item).

### **5.3.5 Strength test**

#### **5.3.5.1 40 m/s opening shock**

The emergency parachute (in its standard inner container and packed according to the user's manual instructions) is stowed on the drop test device. The test parachute's riser (or both risers in the case of a

two riser parachute) is (are) connected to the single anchor point on the drop test device using the connector(s) specified and supplied by the parachute manufacturer.

The drop test device is accelerated to a straight line velocity of 40 m/s and the parachute deployed using its handle or handle attachment point by a static line attached to a drogue chute or similar low force deployment system.

The test is carried out twice with the same parachute.

Providing that the 40 m/s speed is obtained in a straight line and the parachute does not touch the ground before opening completely, then strength test deployments can be made from a moving vehicle or by free-fall from a high bridge, a balloon, or an aircraft or any other suitable and repeatable method.

#### **5.3.5.2 60 m/s opening shock**

The emergency parachute (in its standard inner container and packed according to the user's manual instructions) is stowed on the drop test device.

The test parachute's riser (or both risers in the case of a two riser parachute) is (are) connected to the single anchor point on the drop test device using the connector(s) specified and supplied by the parachute manufacturer. The mass is accelerated to a straight line velocity of 60 m/s and the parachute deployed using its handle or handle attachment point by a static line attached to a drogue chute or similar low force deployment system.

The test is carried out twice with the same parachute. Providing that the 60 m/s speed is obtained in a straight line and the parachute does not touch the ground before opening completely, then strength test deployments can be made from a moving vehicle or by free-fall from a high bridge, a balloon, or an aircraft or any other suitable and repeatable method.

#### **5.3.6 Additional tests for steerable parachutes**

Check whether every other flight procedure and/or configuration described in the user's manual can be flown safely.

This requirement may be satisfied by the manufacturer producing suitable and acceptable evidence (e.g. video).

## **6 Test files**

### **6.1 Test file information**

The test file shall include:

- a) version of the current EN 12491;
- b) name and address of the manufacturer;
- c) name and address of the person or company presenting the parachute system for testing (if different from manufacturer);
- d) model and reference of the emergency parachute system tested;
- e) detail of whether test 5.3.5.1 or 5.3.5.2 was performed;
- f) results of the tests, i.e. values of loads in newtons and load times in seconds; including the atmospheric data described in Annex B;
- g) name and address of the testing laboratory;

h) unique identifying test reference number.

## **6.2 Items accompanying the test files**

The following items shall accompany the test files and be filed by the testing laboratory:

- a) video recording of the tests;
- b) manufacturing record;
- c) user's manual;
- d) the parachute system that has undergone strength testing according to 5.3.5.

This documentation shall be archived for a minimum of 15 years and the tested parachute system for a minimum of 5 years.

## **7 Manufacturing record**

The manufacturing record supplied by the manufacturer shall contain the following information:

- a) name and address of manufacturer;
- b) name of model;
- c) year (four digits) and month of manufacture of the sample tested;
- d) maximum payload;
- e) user's manual;
- f) dimensioned and toleranced drawings.

All the materials used shall be listed with:

- name of the material;
- the name and references of the manufacturer;
- its specific use in the emergency parachute system;
- the characteristics and tests carried out on this material by the supplier or manufacturer.

## **8 User's manual**

The user's manual should be supplied in English and in the majority language(s) of any country in which the parachute is intended to be sold.

It shall always accompany the parachute. The test laboratory shall check that the manual includes at least the following elements:

- a) general information:
  - 1) parachute system model name;
  - 2) name and address of the manufacturer;

- 3) name and address of person or company having presented the parachute system for testing (if different from manufacturer);
- 4) maximum payload (mass) in kg; ('payload' is the total weight of all the items suspended from the parachute.);
- 5) minimum payload (mass) in kg;
- 6) introduction to the intended use of the parachute system;
- 7) speed warning; if the strength test 5.3.5.1 has been passed:

**WARNING — Not suitable for use at speeds in excess of 32 m/s (115 km/h);**

or, if the strength test 5.3.5.2 has been passed:

**WARNING — Not suitable for use at speeds in excess of 49 m/s (176 km/h);**

- 8) deployment system warning: this parachute system has been tested and found compliant using the original manufacturer's inner container. Use of any other inner container may produce different results, including failures;
  - 9) version and date of issue of the user's manual;
- b) dimensions, illustrations and characteristics:
- 1) overall illustration identifying all components essential for operation;
  - 2) configuration and number of risers;
- c) manufacturer's recommendations on installation, connection and deployment (and piloting techniques if steerable);

In particular these recommendations shall describe and specify:

- 1) installation and connection instructions (which shall include an extraction/security check procedure), the avoidance of any fabric to fabric connections and recommendations on suitable screwed connector sizes and shapes;
- 2) deployment instructions;
- 3) steering instructions and any other special procedures (if steerable);
- 4) procedures to be followed if the parachute is to be used with an alternative inner container:

**WARNING — Use of this parachute with any alternative inner container: the speed of opening and opening shock test has been completed using the inner container supplied. Use of any other inner container may produce different results (including failure);**

- d) repacking, repair and maintenance instructions;

In particular these instructions shall describe and specify:

- 1) recommended frequency of inspection and repacking;

- 2) repacking instructions;
- 3) detailed instructions on any repair and maintenance procedures that can be performed without special knowledge or special machinery;
- 4) list of spare parts, including the specification of any replaceable components, such as rubber bands; and information on how to obtain them;
- 5) manufacturer's recommended life span of the parachute.

The pilot shall be able, using only the information in the user's manual:

- to attach the emergency parachute to the harness;
- to maintain it;
- re-pack it;
- and to use it if the need arises.

## 9 Marking

The conformity of the emergency parachute to the requirements of this standard shall be stated on stamps or labels permanently fixed to the canopy and to the deployment bag, which shall include the following information (NB: The speed warning will be stated at 81 % of the value actually tested. This introduces a 1,5 factor of safety):

- a) manufacturer's name;
- b) emergency parachute model name;
- c) year (four digits) and month of manufacture;
- d) maximum payload;
- e) manufacturer recommended minimum payload in kg;
- f) flat area;
- g) serial number;
- h) if the strength test 5.3.5.1 has been passed:

**WARNING — Not suitable for use at speeds in excess of 32 m/s (115 km/h);**

or, if the strength test 5.3.5.2 has been passed:

**WARNING — Not suitable for use at speeds in excess of 49 m/s (176 km/h);**

- i) total length (from harness attachment to canopy top when uninflated);
- j) the number of this European Standard, i.e. EN 12491.

An example of a marking label is given in Annex A.



**Annex A**  
(informative)

**Example of marking label**

Emergency parachute for paragliding complying with EN 12491

Name of test body: .....

Make: ..... Model: ..... Flat area: .....m<sup>2</sup>

Total length (Harness attachment to canopy top uninflated): ..... m

Year (four digits) and month of manufacture: .....

Serial no: .....

Maximum payload: ..... kg

Manufacturer recommended minimum payload: ..... kg

WARNING: NOT SUITABLE FOR USE AT SPEEDS IN EXCESS OF 32 m/s (115 km/h)

BEFORE USE REFER TO THE USER'S MANUAL

## Annex B (normative)

### Formula to be used for correcting the test mass for differences from ICAO standard atmosphere

$$m_{\text{corr}} = m_{\text{dec}} \times \frac{p \times T_0}{p_0 \times T}$$

where

|                   |  |
|-------------------|--|
| $m_{\text{corr}}$ | corrected mass;  |
| $m_{\text{dec}}$  | declared maximum payload;  |
| $p$               | ground level atmospheric pressure (hPa) at the test location for test 5.3.4; |
| $p_0$             | ICAO standard atmospheric pressure at MSL (1 013,25 hPa);                    |
| $T$               | ground level temperature (K) at the test location for test 5.3.4;            |
| $T_0$             | ICAO standard temperature at MSL (288 K).                                    |

## Annex C (informative)

### Example drop test device

Figure C.1 presents an example of drop test devices to be used.

Dimensions in millimetres

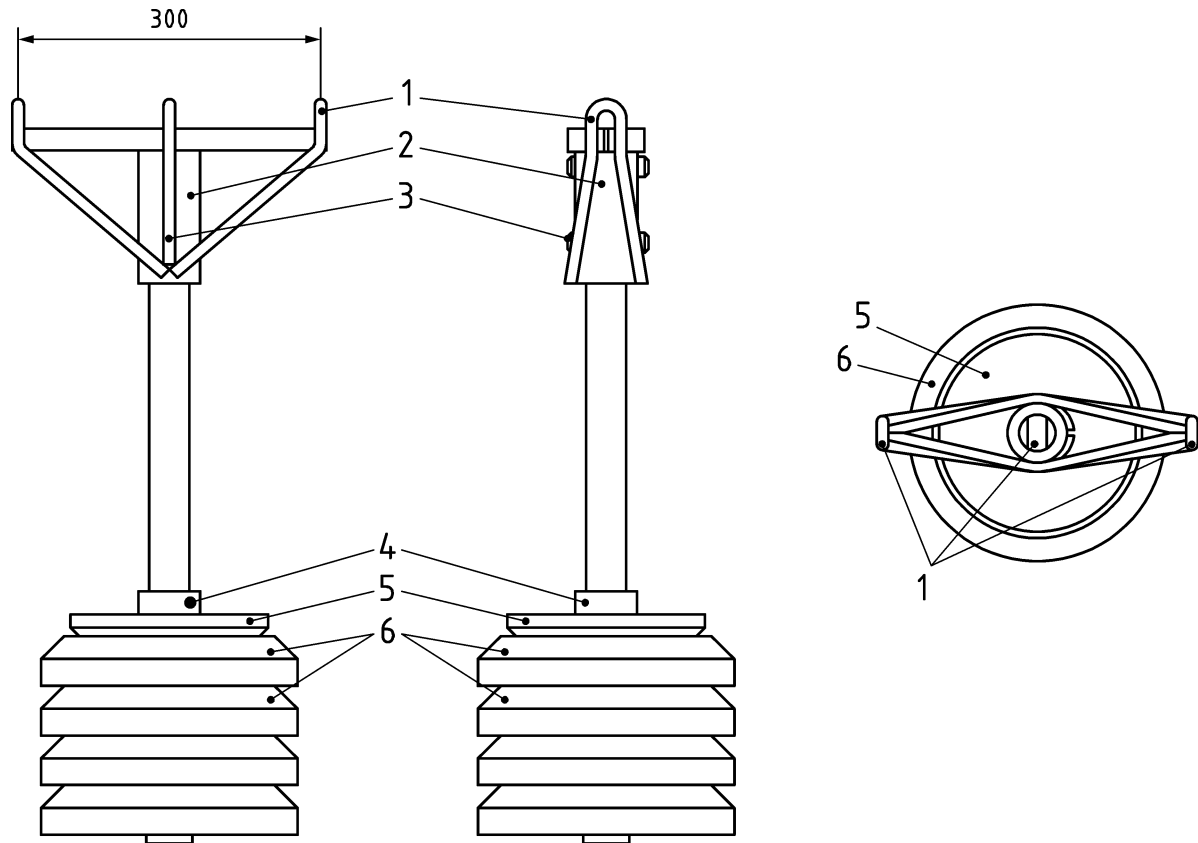

#### Key

- 1 emergency parachute attachment point(s)
- 2 head part, removable to allow disks to be inserted
- 3 bolts securing head part (2)
- 4 clamp securing the ballast disks
- 5 removable ballast disk (steel, 5 kg)
- 6 removable ballast disks (steel, 20 kg)

Figure C.1 — Example drop test device





